

TOWER 20 AM MCW

Outdoor Wireless Octa-PIR™ Detector with Anti-Mask



Installation Instructions

1. INTRODUCTION

DRAFT

Detector's Features

- Patented 8 independent PIR matrix (Octa-PIR™) with true motion recognition (TMR) processing for each of the 8 PIR detectors and central motion processing - can distinguish between a moving intruder and moving trees and bushes.
- Immunity to pets weighing up to 18 Kg (40lb), not pet alley.
- Smart protection against snow, rain, dust, wind and direct sunlight.
- Tamper protection when the detector is opened, removed from mounting surface or removed from bracket.
- Alarm LED is visible under strong sunlight.

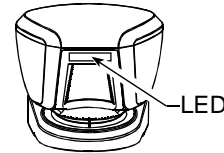

Figure 1 - TOWER 20 AM MCW

- Day/night recognition for sophisticated operation.
- Robust housing.
- Anti masking mode.
- Coverage: 12 meters / 90°.

2. SPECIFICATIONS

OPTICAL

Sensors: 8 dual-element Pyroelectric sensors provide 16 element array.

Max. Coverage: 12 meters / 90°.

Detector Technology: 8 independent PIR detectors

Pet-immune: Up to 18Kg ?? (40lb. ??)

ELECTRICAL

Input Power: Two 3V CR123A Lithium batteries.

Battery life: 3 years (for typical use).

WIRELESS

Frequency (MHz): 315, 433, 868.95.

Communication protocol: PowerCode

MOUNTING

Mounting type: Wall mounting

Mounting height: 1.8 to 3.0 meters

Vertical adjustment: 0° to -10°, in 2.5° steps

Horizontal adjustment: -45° to +45°, in 5° steps

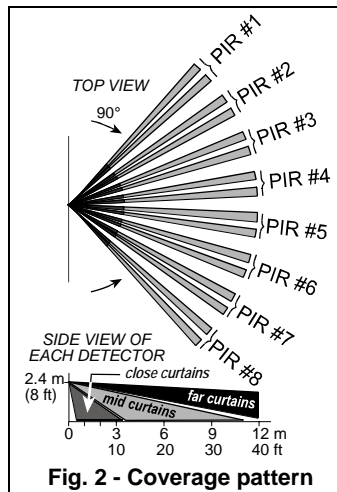

Fig. 2 - Coverage pattern

ENVIRONMENTAL

Operating Temperature: -30°C ??? to 60°C

Storage Temperature: -30°C to 60°C

Humidity: 95% max.

White light immunity: Above 6500 lux

PHYSICAL

Dimensions (height x length x width:

157x147x124mm (6-3/16 x 5-13/16 x 4-7/8").

Weight:

Color: White or off-white gray ??

STANDARDS COMPLIANCE

Designed to Comply with EN 50131-2-2 "environmental class IV".

EMI Immunity: CE and EN 50131 (min. 20 V/m 10 to 1000 MHz, min. 10 V/m 1Ghz to 2Ghz).

US Patents: 7250605, 6818881, 5693943

3. INSTALLATION

3.1 DIP Switches Setup

Remove the 2 detector's bottom covers (see Figure 3. steps 4-8) to gain access to the DIP switches. Set the DIP switches according to the following table:

DIP SW #	Function	Description	Default
1	Alarm LED OFF/ON	OFF: Motion and masking alarm LED is disabled (OFF). ON: Motion and masking alarm LED is enabled (ON).	OFF
2	24H / night only	OFF: Motion alarms are always enabled (24 hours). ON: Motion alarms are enabled only at dark (night).	OFF
3	PIR signal processing modes	TBD. ???	TBD??
4			

3.2 Installation

See Figure 3.

3.3 Adjustments

Perform detector's horizontal adjustment, vertical adjustment and final closure, as shown in Figure 4.

3.4 Test

- A.** Set the detector in Walk-Test mode, as follows:
Open the detector bottom cover (see Fig. 3, steps 4 - 6) and then close it. The LED will flash for 30 seconds and then the detector will enter into 15 minutes walk-test mode.

Note: The detector automatically enters into 15 minutes walk-test mode after battery installation or Tamper switch recovery.

- B.** Walk into the detector's field of view at the expected far edge of the coverage area. Verify that each time your motion is detected the LED lights for 2 seconds and the control panel receives the alarm. If required, perform detector's horizontal / vertical readjustments.

Important! Instruct the user to perform walk test at least once a week, to verify proper operation of the detector.

- C.** Place a piece of cardboard on the detector's front side, to deliberately mask the optical window. After 30 seconds, the LED should flash for 5 seconds (see table below) and the alarm control panel should receive the masking alarm.

- D.** Remove the masking from the detector's front side. The LED should extinguish (after a few seconds).

LED operation:

Event	LED Operation
First 30 sec after battery insertion or closing the detector cover	slow flashing
Tamper switch open	ON 2 sec.
Mask detection (*) (**)	fast flashing 5 sec.
PIR detection (**)	ON 2 sec.

* The LED flashes fast continuously during walk-test mode.

** LED ON/OFF control by DIP switch #1 (see par. 3.1).

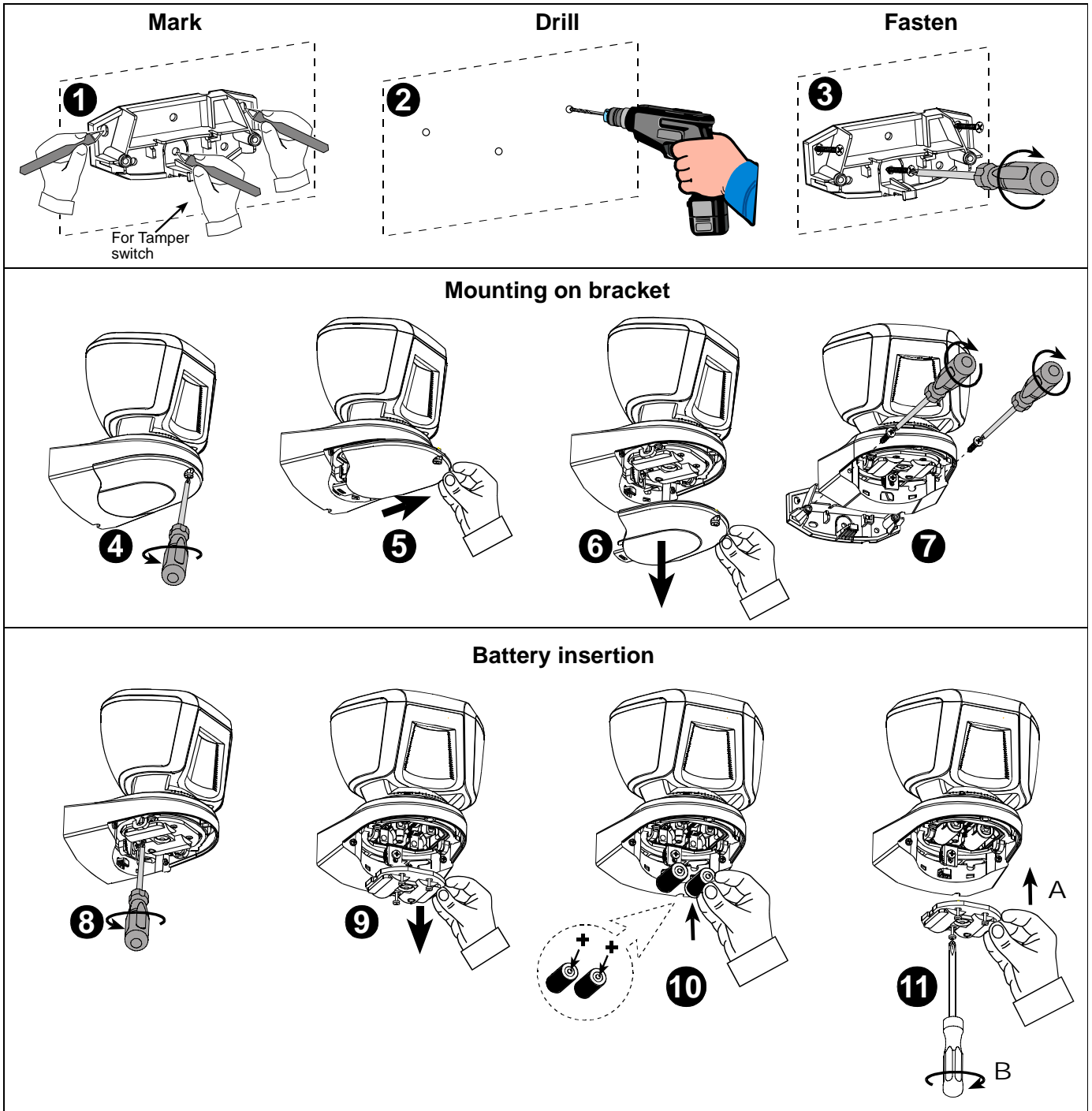
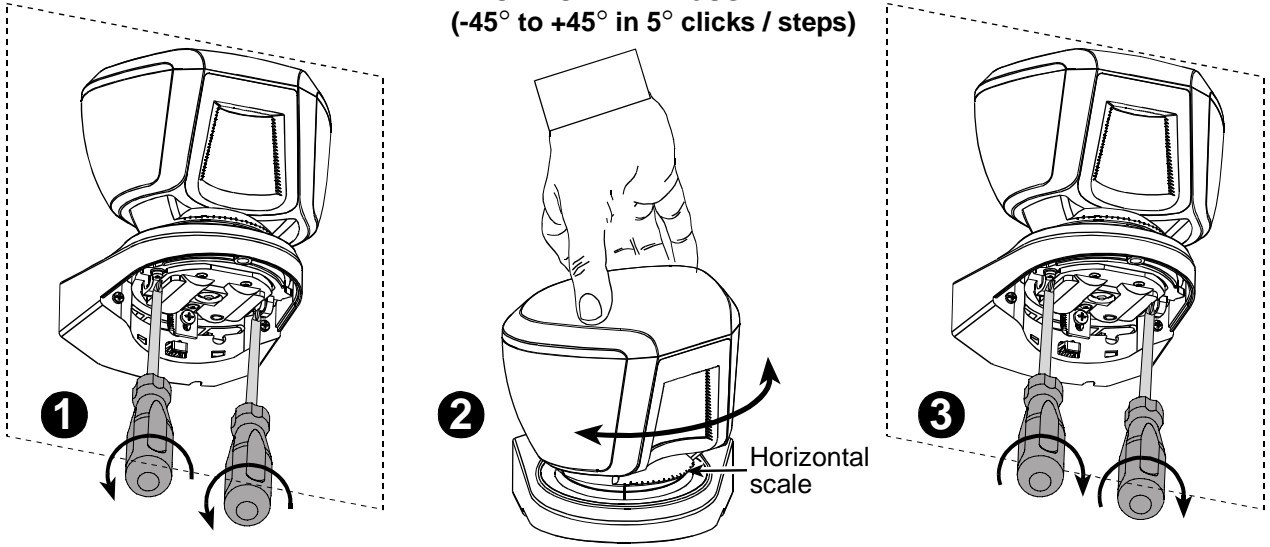
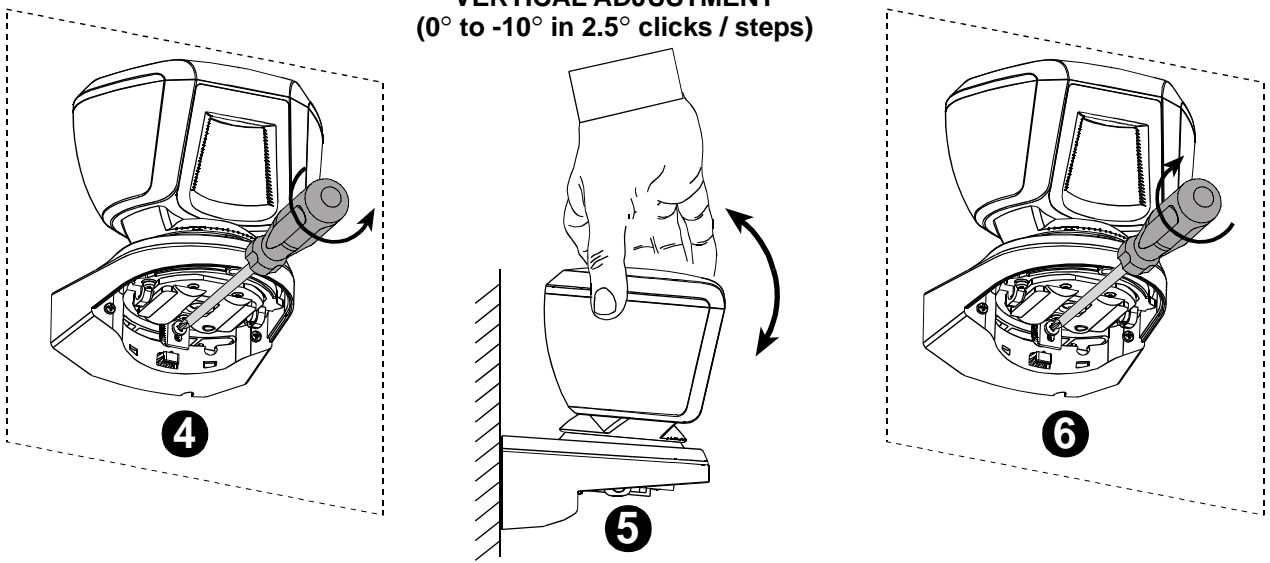

Figure 3 - Installation

HORIZONTAL ADJUSTMENT
(-45° to +45° in 5° clicks / steps)



VERTICAL ADJUSTMENT
(0° to -10° in 2.5° clicks / steps)



COVER CLOSURE

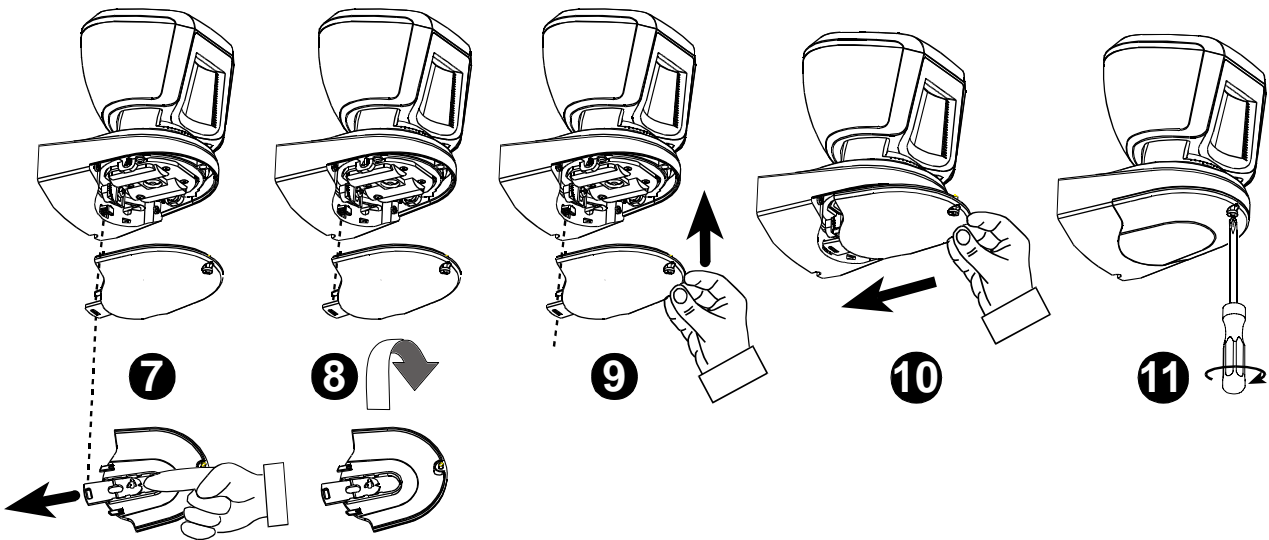

Figure 4 - Adjustment and Cover Closure

NOTE: THE MANUFACTURER IS NOT RESPONSIBLE FOR ANY RADIO OR TV INTERFERENCE CAUSED BY UNAUTHORIZED MODIFICATIONS TO THIS EQUIPMENT. SUCH MODIFICATIONS COULD VOID THE USER'S AUTHORITY TO OPERATE THE EQUIPMENT.

WARRANTY

Visonic Limited (the "Manufacturer") warrants this product only (the "Product") to the original purchaser only (the "Purchaser") against defective workmanship and materials under normal use of the Product for a period of twelve (12) months from the date of shipment by the Manufacturer.

This Warranty is absolutely conditional upon the Product having been properly installed, maintained and operated under conditions of normal use in accordance with the Manufacturers recommended installation and operation instructions. Products which have become defective for any other reason, according to the Manufacturers discretion, such as improper installation, failure to follow recommended installation and operational instructions, neglect, willful damage, misuse or vandalism, accidental damage, alteration or tampering, or repair by anyone other than the manufacturer, are not covered by this Warranty.

The Manufacturer does not represent that this Product may not be compromised and/or circumvented or that the Product will prevent any death and/or personal injury and/or damage to property resulting from burglary, robbery, fire or otherwise, or that the Product will in all cases provide adequate warning or protection. The Product, properly installed and maintained, only reduces the risk of such events without warning and it is not a guarantee or insurance that such events will not occur.

THIS WARRANTY IS EXCLUSIVE AND EXPRESSLY IN LIEU OF ALL OTHER WARRANTIES, OBLIGATIONS OR LIABILITIES, WHETHER WRITTEN, ORAL, EXPRESS OR IMPLIED, INCLUDING ANY WARRANTY OF MERCHANTABILITY OR FITNESS FOR A PARTICULAR PURPOSE, OR OTHERWISE. IN NO CASE SHALL THE MANUFACTURER BE LIABLE TO ANYONE FOR ANY CONSEQUENTIAL OR INCIDENTAL DAMAGES FOR BREACH OF THIS WARRANTY OR ANY OTHER WARRANTIES WHATSOEVER, AS AFORESAID.

THE MANUFACTURER SHALL IN NO EVENT BE LIABLE FOR ANY SPECIAL, INDIRECT, INCIDENTAL, CONSEQUENTIAL OR PUNITIVE DAMAGES OR FOR LOSS, DAMAGE, OR EXPENSE, INCLUDING LOSS OF USE, PROFITS, REVENUE, OR GOODWILL, DIRECTLY OR INDIRECTLY ARISING FROM PURCHASER'S USE OR INABILITY TO USE THE PRODUCT, OR FOR LOSS OR DESTRUCTION OF OTHER PROPERTY OR FROM ANY OTHER CAUSE, EVEN IF MANUFACTURER HAS BEEN ADVISED OF THE POSSIBILITY OF SUCH DAMAGE.

THE MANUFACTURER SHALL HAVE NO LIABILITY FOR ANY DEATH, PERSONAL AND/OR BODILY INJURY AND/OR DAMAGE TO PROPERTY OR OTHER LOSS WHETHER DIRECT, INDIRECT, INCIDENTAL, CONSEQUENTIAL OR OTHERWISE, BASED ON A CLAIM THAT THE PRODUCT FAILED TO FUNCTION.

However, if the Manufacturer is held liable, whether directly or indirectly, for any loss or damage arising under this limited warranty, **THE MANUFACTURER'S MAXIMUM LIABILITY (IF ANY) SHALL NOT IN ANY CASE EXCEED THE PURCHASE PRICE OF THE PRODUCT**, which shall be fixed as liquidated damages and not as a penalty, and shall be the complete and exclusive remedy against the Manufacturer. When accepting the delivery of the Product, the Purchaser agrees to the said conditions of sale and warranty and he recognizes having been informed of.

Some jurisdictions do not allow the exclusion or limitation of incidental or consequential damages, so these limitations may not apply under certain circumstances.

The Manufacturer shall be under no liability whatsoever arising out of the corruption and/or malfunctioning of any telecommunication or electronic equipment or any programs.

The Manufacturers obligations under this Warranty are limited solely to repair and/or replace at the Manufacturer's discretion any Product or part thereof that may prove defective. Any repair and/or replacement shall not extend the original Warranty period. The Manufacturer shall not be responsible for dismantling and/or reinstallation costs. To exercise this Warranty the Product must be returned to the Manufacturer freight pre-paid and insured. All freight and insurance costs are the responsibility of the Purchaser and are not included in this Warranty.

This warranty shall not be modified, varied or extended, and the Manufacturer does not authorize any person to act on its behalf in the modification, variation or extension of this warranty. This warranty shall apply to the Product only. All products, accessories or attachments of others used in conjunction with the Product, including batteries, shall be covered solely by their own warranty, if any. The Manufacturer shall not be liable for any damage or loss whatsoever, whether directly, indirectly, incidentally, consequentially or otherwise, caused by the malfunction of the Product due to products, accessories, or attachments of others, including batteries, used in conjunction with the Products. This Warranty is exclusive to the original Purchaser and is not assignable.

This Warranty is in addition to and does not affect your legal rights. Any provision in this warranty which is contrary to the Law in the state or country where the Product is supplied shall not apply.

Warning: The user must follow the Manufacturer's installation and operational instructions including testing the Product and its whole system at least once a week and to take all necessary precautions for his/her safety and the protection of his/her property.

1/08



W.E.E.E. Product Recycling Declaration

For information regarding the recycling of this product you must contact the company from which you originally purchased it. If you are discarding this product and not returning it for repair then you must ensure that it is returned as identified by your supplier. This product is not to be thrown away with everyday waste. Directive 2002/96/EC Waste Electrical and Electronic Equipment.



VISIONIC LTD. (ISRAEL): P.O.B 22020 TEL-AVIV 61220 ISRAEL. PHONE: (972-3) 645-6789, FAX: (972-3) 645-6788

VISIONIC INC. (U.S.A.): 10 NORTHWOOD DRIVE, BLOOMFIELD CT. 06002-1376. PHONE: (860) 243-0833, (800) 223-0020 FAX: (860) 242-8094

VISIONIC LTD. (UK): FRASER ROAD, PRIORY BUSINESS PARK, BEDFORD MK44 3WH. PHONE: (0870) 7300800 FAX: (0870) 7300801

INTERNET: www.visonic.com

©VISIONIC LTD. 2008 TOWER 20 AM MCW D-30160 (REV. 0, 3/08)



MADE IN
ISRAEL