

EAR FORCE®
X42

**Wireless Dolby® Surround Sound Gaming Headset /
Casque pour jeux vidéo sans fil avec son Surround Dolby**



Package Contents / Contenu de la boîte



X42 Headset /
Casque X42



X42 Transmitter /
Transmetteur X42

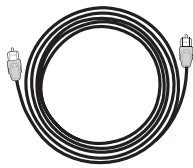

Digital Optical Cable /
Câble optique numérique



XBOX 360 Talkback Cable /
Câble de réponse XBOX 360

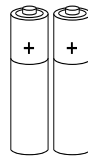

(2) AAA Batteries /
2 piles « AAA »



Turtle Beach Sticker /
Autocollant Turtle Beach

System Requirements / Configuration requise

Xbox 360® game console with one of the following Xbox® cables to support digital audio output:

- Component A/V cable
- VGA A/V cable
- S-Video A/V cable
- Advanced SCART A/V cable
- HDMI audio adapter cable
- Composite A/V cable with digital output

Available USB port

Console de jeux Xbox 360 avec sortie optique ou l'un des câbles suivants pour la sortie optique:

- Câble adaptateur audio HDMI
- Câble AV HD composant
- Câble S-Vidéo
- Câble AV composite avec sortie numérique
- Câble AV VGA
- Câble AV SCART avancé

Requiert une alimentation USB

X42 Headset / Casque X42

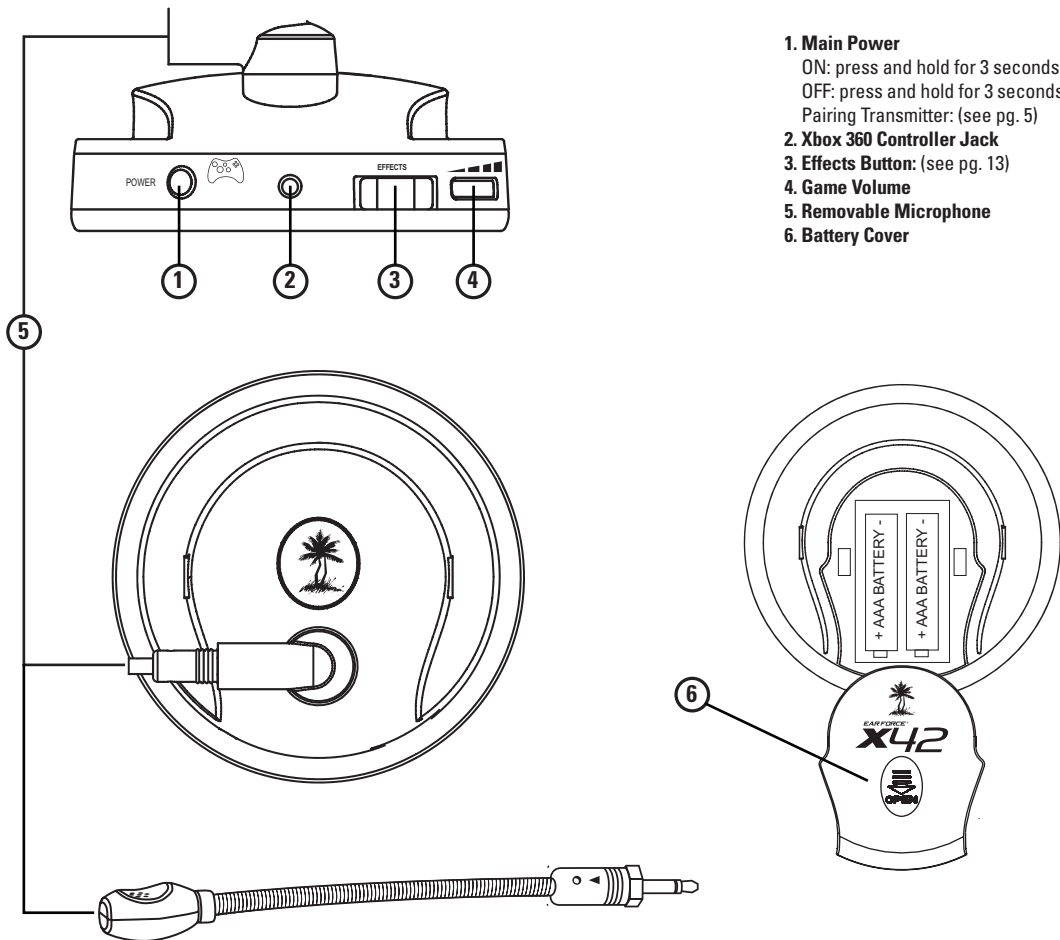

FRANÇAIS

1. Alimentation:

Marche: appuyer sur la touche pendant 3 secondes.

Arrêt: appuyer sur la touche pendant 3 secondes.

Couplage de l'émetteur: (voir page 5).

2. Prise de commande de la Xbox 360

3. Effets: (voir page 13)

4. Volume de jeu

5. Microphone amovible

6. Couvercle des piles

DEUTSCH

1. Hauptstromversorgung:

EIN: Für 3 Sekunden gedrückt halten.

AUS: Für 3 Sekunden gedrückt halten.

Pairing-Transmitter: (siehe S. 5)

2. XBOX 360 Controller-Anschlussbuchse

3. Effekten-Taste: (siehe S. 13)

4. Lautstärke – Spiel

5. Abnehmbares Mikrophon

6. Batterieabdeckung

ITALIANO

1. Alimentazione:

Accensione (ON): premere per 3 secondi.

Spegnimento (OFF): premere per 3 secondi.

Abbinamento trasmettitori: (vedere pag. 5)

2. Spinotto di controllo XBOX 360

3. Effetti pulsante: (vedere pag. 13)

4. Volume gioco

5. Microfono staccabile

6. Coperchio batteria

PORTUGUÊS

1. Alimentação:

Ligado: pressione e segure por 3 segundos.

Desligado: pressione e segure por 3 segundos.

Transmissor de em parelhamento: (consulte pág.5)

2. Conector do controle do XBOX 360

3. Botão de efeitos: (consulte pág. 13)

4. Volume do jogo

5. Microfone removível

6. Tampa de bateria

ESPAÑOL

1. Encendido:

ON: Oprimirlo durante 3 segundos.

OFF: Oprimirlo durante 3 segundos.

Enlace del transmisor: (véase página 5)

2. Enchufe del controlador de XBOX 360

3. Efectos botón: (véase página 13)

4. Volumen de juegos

5. Micrófono extraíble

6. Tapa de pilas

SVENSK

1. Strömförsörjning

PÅ: tryck och håll nere i 3 sekunder.

AV: tryck och håll nere i 3 sekunder.

Sändare för sammanlänkning: (se sid. 5)

2. XBOX 360 uttag för handkontroll

3. Effekter knappen: (se sid. 13)

4. Spelvolym

5. Löstagbar mikrofon

6. Batteriskydd

DANSK

1. Tænd/sluk knap:

Tænd: tryk og hold nede i 3 sekunder.

Sluk: tryk og hold nede i 3 sekunder.

Parrings transmitter: (se s. 5)

2. XBOX 360 controllerstik

3. Effekter-knap: (se s. 13)

4. Game Bind

5. Fjernbar mikrofon

6. Batterihylster

NEDERLANDS

1. POWER-knop:

Aan: 3 seconden ingedrukt houden.

Uit: 3 seconden ingedrukt houden.

Zender koppelen: (zie p. 5)

2. Aansluiting voor XBOX 360-controller

3. Effecten-knop: (zie p. 13)

4. Deel Game

5. Afneembare microfoon

6. Batterijklepje

X42 Transmitter / Émetteur X42



1. Digital Input LED
2. Surround Sound LED
3. Dolby® Digital LED
4. Power/Link LED
5. Digital Input and Output
6. Analog Input
7. Pairing Button (see pg. 5)
8. Surround Angles Button (see pg. 11)
9. Surround Sound ON/OFF

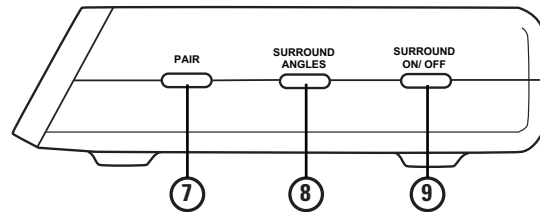
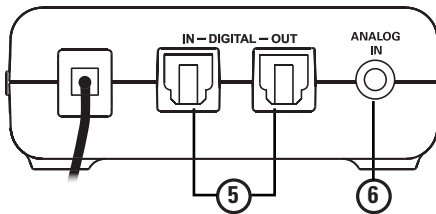

FRANÇAIS

1. DEL d'entrée numérique
2. DEL son surround
3. DEL Dolby Digital
4. DEL d'alimentation/couplage:
5. Entrée/sortie numérique
6. Entrée analogique
7. Bouton de couplage (voir p. 5)
8. Bouton d'angles du son surround (voir p. 11)
9. Marche/Arrêt du son surround

DEUTSCH

1. Digitaleingang-LED
2. Surround-Sound-LED
3. Dolby Digital-LED
4. Power-/Pairing-LED
5. Digitaleingang /-ausgang
6. Analogeingang
7. Pairing-Taste (siehe S. 5)
8. Surround-Winkel-Taste (siehe S. 11)
9. Surround-Sound Ein/Aus

ITALIANO

1. LED ingresso digitale
2. LED audio surround
3. LED Dolby Digital
4. LED accensione/abbinamento:
5. Ingresso / uscita digitale
6. Ingresso analogico
7. Tasto di accoppiamento (vedere pag. 5)
8. Tasto Surround Angles (Ango lazione surround) (vedere pag. 11)
9. Audio surround On/Off

PORTUGUÊS

1. LED de entrada digital
2. LED de som surround
3. LED Dolby Digital
4. LED de energia/conexão:
5. Entrada / saída digital
6. Entrada analógica
7. Botão de conexão (consulte a pág. 5)
8. Botão de ângulos surround (consulte a pág. 11)
9. Som surround Liga/Desliga

ESPAÑOL

1. LED con entrada digital
2. LED con sonido envolvente
3. LED Digital Dolby
4. LED de Encendido/Enlace Encendido permanentemente
5. LED digital Dolby
6. Entrada / salida digital
7. Botón de enlace (véase la página 5)
8. Botón de ángulos envolventes (véase la página 11)
9. Encendido/Apagado de sonido envolvente

SVENSK

1. Digital ingång LED
2. Surroundljud LED
3. Dolby Digital LED
4. På/Av- och sammanlänkningslampa
5. Digital ingång / utgång
6. Analog ingång
7. Sammanlänkningsknapp (se sida 5)
8. Surroundvinkelknapp (se sida 11)
9. Surroundljud På/Av

DANSK

1. Lysdiode til digital indgang
2. Lysdiode til surroundsound
3. Lysdiode til Dolby Digital
4. Strøm/Parrings LED
5. Digital indgang / output
6. Analog indgang
7. Parringsknop (se side 5)
8. Knop til surround-vinkler (se side 11)
9. Surround sound tændt/slukket

NEDERLANDS

1. LED-lampje digitale ingang
2. LED-lampje surround sound
3. Dolby Digital LED-lampje
4. Aan/uit-/koppelingsledje
5. Digitale ingang / uitgang
6. Analoge ingang
7. Koppelingsknop (zie p. 5)
8. Knop surround sound-richtingen (zie p. 11)
9. Surround sound aan/uit

Pairing the Headset and Transmitter / Couplage du casque et de l'émetteur

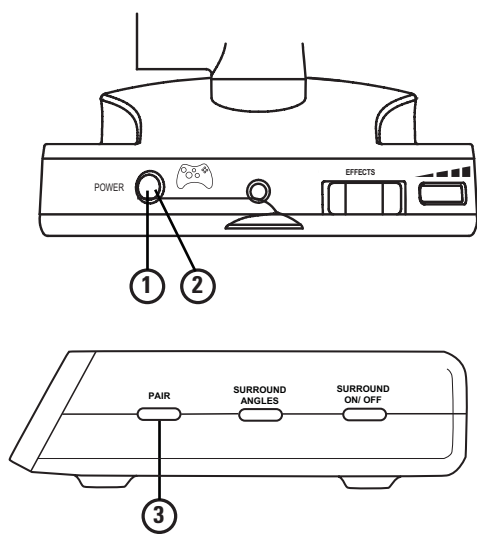

Step 1:

Make sure the Headset is OFF.
(The LED on the Headset should be OFF)

Step 2:

Press and hold the POWER button on the Headset for more than 6 seconds. A tone will sound and the LED on the Headset will begin to blink rapidly.

Step 3:

Press and hold the PAIR button on the Transmitter for 3 seconds. The LED on the Transmitter will begin to blink rapidly.

After a few seconds, the Transmitter LED will be solid and the Headset will be paired.

FRANÇAIS

1. Éteindre le casque.
 2. Maintenir la touche POWER (TENSION) enfoncée pour plus de 6 secondes.
 3. Maintenir la touche PAIR (COUPLER) enfoncée pour plus de 3 secondes.
- Après plusieurs secondes, la LED de l'émetteur sera allumée de façon permanente et le casque sera couplé.

DEUTSCH

1. Headset AUSSCHALTEN.
 2. Die Headset-POWER-Taste drücken und mindestens 6 Sekunden lang gedrückt halten.
 3. Die Transmitter-PAIR-Taste drücken und 3 Sekunden lang gedrückt halten.
- Nach einigen Sekunden leuchtet die Transmitter-LED stetig auf, und das Headset-Pairing hat stattgefunden.

ITALIANO

1. Spegner la cuffia.
 2. Tenere premuto il pulsante di accensione (POWER) cuffie per più di 6 secondi.
 3. Tenere premuto il pulsante di accoppiamento (PAIR) del trasmettitore per 3 secondi.
- Dopo qualche secondo, il LED del trasmettitore si illuminerà fisso e la cuffia sarà accoppiata.

PORTUGUÊS

1. Desligue o fone de ouvido.
 2. Mantenha pressionado o botão POWER (liga/desl.) do fone de ouvido por mais de 6 segundos.
 3. Mantenha pressionado o botão PAIR (conexão) do transmissor por 3 segundos.
- Após alguns segundos, o LED do transmissor permanecerá aceso e o fone de ouvido estará conectado.

ESPAÑOL

1. Apagar los auriculares.
 2. Mantener oprimido el botón de encendido (Power) de los auriculares durante más de 6 segundos.
 3. Mantener oprimido el botón de enlace (Pair) del transmisor durante 3 segundos.
- Después de algunos segundos, el LED del transmisor quedará permanentemente encendido y el enlace con los auriculares se habrá establecido.

SVENSK

1. Stäng av headsetet.
 2. Tryck och håll inne headsetets POWER-knapp i minst 6 sekunder.
 3. Tryck och håll inne sändarens sammanlänkningsknapp i 3 sekunder
- Efter ett par sekunder lyser lampan på sändaren utan att blinka och headsetet är sammanlänkat.

DANSK

1. Sluk for (OFF) headsettet.
 2. Tryk og hold headsettets STRØMKNAP (POWER) nede i mere end 6 sekunder.
 3. Tryk og hold transmitterens PARRINGSKNAP (PAIR) nede i 3 sekunder.
- Efter et par sekunder vil transmitterens LED være konstant og headsettet vil være parret.

NEDERLANDS

1. Zet de headset uit.
 2. Houd de AAN/UIT-knop van de headset langer dan 6 seconden ingedrukt.
 3. Houd de KOPPELINGS-knop van de zender 3 seconden ingedrukt.
- Na enkele seconden brandt het zenderledje constant en is de headset gekoppeld.

XBOX 360 Setup / Configuration XBOX 360

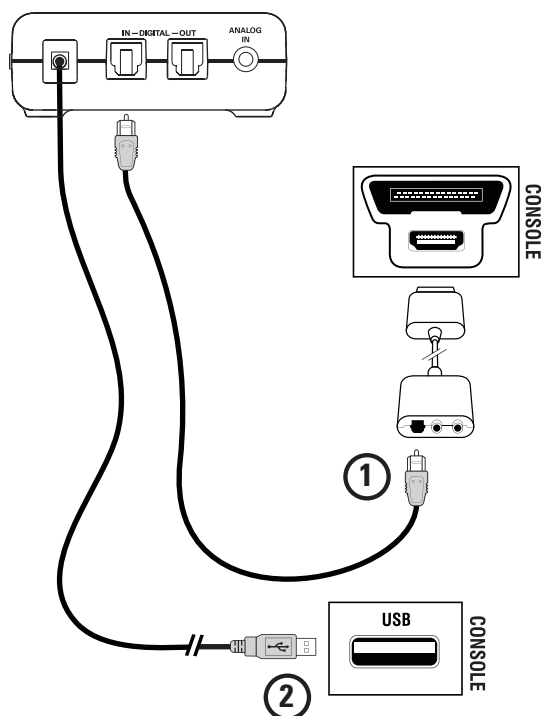

1. Connect the Optical Cable.*
NOTE: Remove the protective caps from each end of the optical cable.
2. Connect the Transmitter Power Cable.



***NOTE:** Older Xbox 360 models require an Xbox 360 HDMI Audio Adapter Cable for optical audio output (sold separately). If your HDTV has an optical AUDIO OUT jack, you can use it to connect the optical cable to the DSS2 and feed sound from the gaming console to the DSS2.

FRANÇAIS

1. Brancher le câble optique*.

REMARQUE : Retirer les capuchons protecteurs à chaque extrémité du câble optique.

2. Brancher le câble d'alimentation de l'émetteur.

* Les premiers modèles de Xbox 360 nécessitent un câble adaptateur XBOX 360 HDMI vendu séparément.

DEUTSCH

1. Schließen Sie das Lichtleiterkabel an.*

HINWEIS: Entfernen Sie die Schutzkappen von den Kabelenden.

2. Schließen Sie das Transmitter-Netzkabel an.

*Original-XBOX 360-Modelle erfordern ein XBOX 360 HDMI-Adapterkabel (separat erhältlich).

ITALIANO

1. Collegare il cavo ottico.*

NOTA: rimuovere i cappucci protettivi da ciascuna estremità del cavo ottico.

2. Collegare il cavo di alimentazione del trasmettitore.

*I modelli originali di XBOX 360 richiedono un cavo adattatore XBOX 360 HDMI Adapter, venduto separatamente

PORTUGUÊS

1. Conecte o cabo óptico.*

OBS.: Remova a tampa protetora de cada extremidade do cabo óptico.

2. Conecte o cabo de força do transmissor.

*Os modelos originais do XBOX 360 requerem um cabo de adaptador HDMI para XBOX 360, vendido separadamente.

ESPAÑOL

1. Conecte el cable óptico.*

NOTA: Quite la tapa de cada extremo del cable.

2. Conecte el cable de alimentación del transmisor.

* Los modelos XBOX 360 necesitan un cable adaptador HDMI que se vende separadamente.

SVENSK

1. Anslut den optiska digitalkabeln.*

OBS! Ta bort skyddskapseln på varje ände av den optiska digitalkabeln.

2. Anslut strömkabeln till sändaren.

*Ursprungsmodellerna av XBOX 360 kräver en XBOX 360 HDMI-adapterkabel som säljs separat.

DANSK

1. Tilslut det optiske kabel.*

BEMÆRK: Fjern de beskyttende hætter fra begge ender af det optiske kabel.

2. Tilslut transmitterens strømkabel.

*XBOX 360 originale modeller kræver en XBOX 360 HDMI Adapter kabel sælges særskilt.

NEDERLANDS

1. Sluit de optische kabel aan.*

Opmerking: haal de beschermdop van elk uiteinde van de optische kabel af.

2. Sluit de voedingskabel van de zender aan.

*Voor originele XBOX 360-modellen is een apart verkrijgbare XBOX 360 HDMI-adapterkabel vereist.

XBOX 360 Chat Setup / Configuration vocale de la XBOX 360

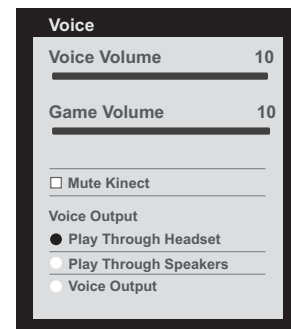
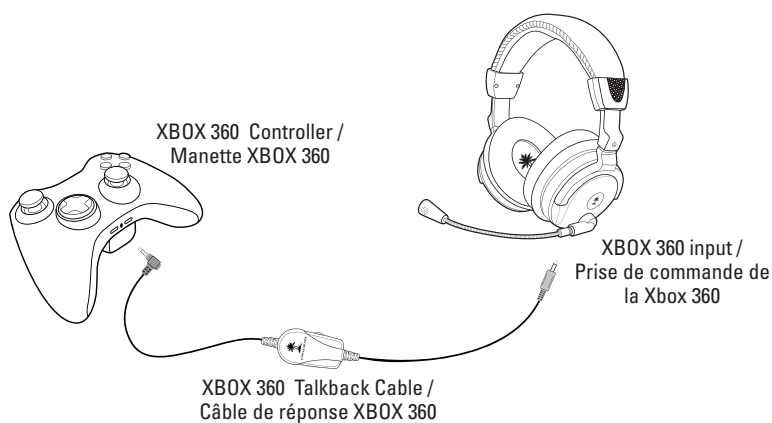

XBOX 360 System Settings:

"Preferences" > "Voice" >
"Play Through Headset".

FRANCAIS

Au tableau de bord de la Xbox 360, sélectionner Paramètres > Préférences > Voix > Son via le casque

DEUTSCH

Wählen Sie in den XBOX 360-Systemeinstellungen "Präferenzen" > "Sprache" > "Im Headset abspielen" aus

ITALIANO

Nelle Impostazioni di sistema della XBOX 360, selezionare "Preferenze" > "Voce" > "Ascolta in cuffia"

PORTUGUÊS

Nas Configurações de Sistema do XBOX 360, selecione "Preferências" > "Voz" > "Reproduzir através do fone de ouvido"

ESPAÑOL

En Configuración del sistema para XBOX 360 seleccione Preferencias > Voz > Reproducir por auriculares

SVENSK

Under "Systeminställningar", välj "Preferences" > "Voice" > "Play Through Headset"

DANSK

Under XBOX 360 systemindstillinger vælger du "Præferencer" > "Stemme" > "Spil gennem headset"

NEDERLANDS

Selecteer in de systeeminstellingen van de XBOX 360 voorkeuren > spraak > spelen via headset

Configure Xbox 360® System Settings / Configurer les paramètres système Xbox 360

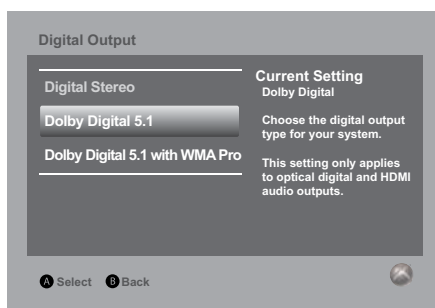

Settings > Audio > Accessory Settings > Audio Device Settings.
Set the "Digital Output" to "Dolby Digital 5.1"

FRANCAIS

Configurer les paramètres système Xbox 360

Settings > Audio > Accessory Settings > Audio Device Settings
(Paramètres > Audio > Paramètres d'accessoires > Paramètres de périphériques audio). Configurez « Digital Output » (« Sortie numérique ») sur « Dolby Digital 5.1 »

DEUTSCH

Konfiguration der Xbox 360 Systemeinstellungen

Zum Auswählen der Audiogeräteinstellungen „Settings > Audio > Accessory Settings > Audio Device Settings“ wählen. „Digital Output“ (Digitalausgang) auf „Dolby Digital 5.1“ einstellen

ITALIANO

Configurazione delle impostazioni di sistema per Xbox 360

Settings > Audio > Accessory Settings > Audio Device Settings
(Impostazioni > Audio > Impostazioni accessori > Impostazioni dispositivo audio). Impostare la "Digital Output" (Uscita digitale) su "Dolby Digital 5.1"

PORTUGUÊS

Configure os ajustes do sistema Xbox 360

Settings > Audio > Accessory Settings > Audio Device Settings
(Configurações > Áudio > Configurações de acessório > Configurações de dispositivo de áudio). Defina a "Digital output" (Saída digital) para "Dolby Digital 5.1"

ESPAÑOL

Establezca la configuración de sistema de Xbox 360

Configuración > Audio > Configuración de accesorios > Configuración de dispositivo de audio. Configure la "Salida digital" en "Dolby digital 5.1"

SVENSK

Konfigurera systeminställningar för Xbox 360

Inställningar > Ljud > Tillbehörsinställningar > Inställningar för ljudenhet. Sätt den "Digitala utgången" på "Dolby Digital 5.1"

DANSK

Konfigurér Xbox 360's systemindstillinger

Indstillinger > Lyd > Tilbehørsindstillinger > Lydenhedsindstillinger. Sæt "Digital udgangssignal" til "Dolby Digital 5.1"

NEDERLANDS

Configureer de instellingen voor het Xbox 360-systeem

Settings > Audio > Accessory Settings > Audio Device Settings.
Zet de "Digital Output" op "Dolby Digital 5.1"

Surround Sound Angles / Angles du Son Surround

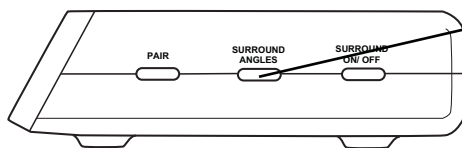

Press the Surround Angles button to cycle through 6 different surround sound angles.

Surround Sound Angle Presets:

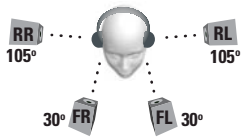

- ① Front Angle; 30 degrees
Rear Angle; 105 degrees

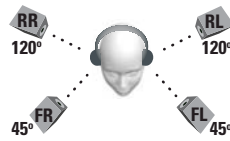

- ② Front Angle; 45 degrees
Rear Angle; 120 degrees

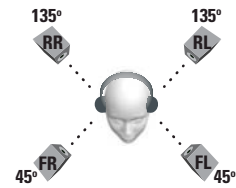

- ③ Front Angle; 45 degrees
Rear Angle; 135 degrees



- ④ Front Angle; 60 degrees
Rear Angle; 120 degrees

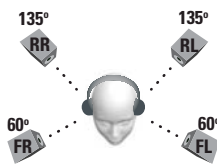

- ⑤ Front Angle; 60 degrees
Rear Angle; 135 degrees

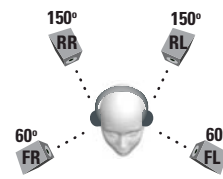

- ⑥ Front Angle; 60 degrees
Rear Angle; 150 degrees

FRANCAIS

Préréglages des angles du son surround

Appuyez sur le bouton Angles surround pour faire défiler 6 différents angles de son surround:

1. Angle avant : 30 degrés, Angle arrière : 105 degrés
2. Angle avant : 45 degrés, Angle arrière : 120 degrés
3. Angle avant : 45 degrés, Angle arrière : 135 degrés
4. Angle avant : 60 degrés, Angle arrière : 120 degrés
5. Angle avant : 60 degrés, Angle arrière : 135 degrés
6. Angle avant : 60 degrés, Angle arrière : 150 degrés

DEUTSCH

Surround-Sound-Winkel-Voreinstellungen

Die Taste „Surround Angles“ drücken, um 6 verschiedene Surround-Winkel der Reihe nach abzurufen:

1. Vorderer Winkel: 30 Grad, Hinterer Winkel: 105 Grad
2. Vorderer Winkel: 45 Grad, Hinterer Winkel: 120 Grad
3. Vorderer Winkel: 45 Grad, Hinterer Winkel: 135 Grad
4. Vorderer Winkel: 60 Grad, Hinterer Winkel: 120 Grad
5. Vorderer Winkel: 60 Grad, Hinterer Winkel: 135 Grad
6. Vorderer Winkel: 60 Grad, Hinterer Winkel: 150 Grad

ITALIANO

Preset delle angolazioni dell'audio surround

Premere il tasto Surround Angles (Angolazione surround) per scegliere tra 6 diverse angolazioni di audio surround:

1. Angolo anteriore: 30 gradi, Angolo posteriore: 105 gradi
2. Angolo anteriore: 45 gradi, Angolo posteriore: 120 gradi
3. Angolo anteriore: 45 gradi, Angolo posteriore: 135 gradi
4. Angolo anteriore: 60 gradi, Angolo posteriore: 120 gradi
5. Angolo anteriore: 60 gradi, Angolo posteriore: 135 gradi
6. Angolo anteriore: 60 gradi, Angolo posteriore: 150 gradi

PORTUGUÊS

Pré-ajustes de ângulo de som surround

Pressione o botão Surround Angles (Ângulos surround) para alternar entre os 6 diferentes ângulos de som surround:

1. Ângulo frontal: 30 graus, ângulo traseiro: 105 graus
2. Ângulo frontal: 45 graus, ângulo traseiro: 120 graus
3. Ângulo frontal: 45 graus, ângulo traseiro: 135 graus
4. Ângulo frontal: 60 graus, ângulo traseiro: 120 graus
5. Ângulo frontal: 60 graus, ângulo traseiro: 135 graus
6. Ângulo frontal: 60 graus, ângulo traseiro: 150 graus

ESPAÑOL

Ángulos de sonido envolvente preestablecidos

Presione el botón Ángulos envolventes para recorrer los 6 ángulos distintos de sonido envolvente:

1. Ángulo delantero: 30 grados, ángulo trasero: 105 grados
2. Ángulo delantero: 45 grados, ángulo trasero: 120 grados
3. Ángulo delantero: 45 grados, ángulo trasero: 135 grados
4. Ángulo delantero: 60 grados, ángulo trasero: 120 grados
5. Ángulo delantero: 60 grados, ángulo trasero: 135 grados
6. Ángulo delantero: 60 grados, ángulo trasero: 150 grados

SVENSK

Snabbval för surroundljudsvinklar

Tryck på surroundvinkelknappen för att gå igenom de sex olika surroundljudsvinklarna:

1. Vinkel framifrån: 30 grader, Vinkel bakifrån: 105 grader
2. Vinkel framifrån: 45 grader, Vinkel bakifrån: 120 grader
3. Vinkel framifrån: 45 grader, Vinkel bakifrån: 135 grader
4. Vinkel framifrån: 60 grader, Vinkel bakifrån: 120 grader
5. Vinkel framifrån: 60 grader, Vinkel bakifrån: 135 grader
6. Vinkel framifrån: 60 grader, Vinkel bakifrån: 150 grader

DANSK

Forudindstillede surround sound-vinkelindstillinger

Tryk på knappen til surround-vinkler for at løbe gennem 6 forskellige surround sound-vinkler:

1. Frontvinkel: 30 grader, bagvinkel: 105 grader
2. Frontvinkel: 45 grader, bagvinkel: 120 grader
3. Frontvinkel: 45 grader, bagvinkel: 135 grader
4. Frontvinkel: 60 grader, bagvinkel: 120 grader
5. Frontvinkel: 60 grader, bagvinkel: 135 grader
6. Frontvinkel: 60 grader, bagvinkel: 150 grader

NEDERLANDS

Fabrieksinstellingen voor de richting van surround sound

Druk op de knop voor surround sound-richtingen om zes verschillende richtingen voor surround sound door te lopen:

1. Hoek vanaf voorkant: 30 graden, hoek vanaf achterkant: 105 graden
2. Hoek vanaf voorkant: 45 graden, hoek vanaf achterkant: 120 graden
3. Hoek vanaf voorkant: 45 graden, hoek vanaf achterkant: 135 graden
4. Hoek vanaf voorkant: 60 graden, hoek vanaf achterkant: 120 graden
5. Hoek vanaf voorkant: 60 graden, hoek vanaf achterkant: 135 graden
6. Hoek vanaf voorkant: 60 graden, hoek vanaf achterkant: 150 graden

Equalizer (EQ) Presets / Préréglages de l'égalisateur

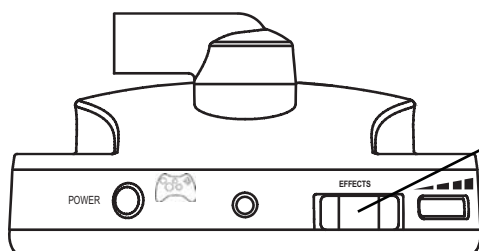

EFFECTS Button /
Bouton EFFECTS

Equalizer (EQ) Presets:

1. Flat
2. Bass Boost
3. Treble Boost
4. Bass and Treble Boost

FRANÇAIS

Présélections de l'égalisateur

Appuyez sur le bouton d'égalisateur pour en faire défiler les préréglages:

1. Sans déviation
2. Ampli basses fréquences
3. Ampli hautes fréquences
4. Ampli basses et hautes fréquences

DEUTSCH

EQ-Voreinstellungen

Die Equalizer-Taste drücken, um die EQ-Voreinstellungen der Reihe nach abzurufen:

1. Linear
2. Bass anheben
3. Höhen anheben
4. Bass + Höhen anheben

ITALIANO

Preset di equalizzazione

Premere il tasto Equalizer (Equalizzatore) per scegliere tra i preset di equalizzazione disponibili:

1. Flat (Neutro)
2. Bass Boost (Esalta bassi)
3. Treble Boost (Esalta alti)
4. Bass + Treble Boost (Esalta bassi + alti)

PORTUGUÊS

Pré-ajustes do equalizador

Pressione o botão Equalizer (Equalizador) para alternar entre os pré-ajustes do equalizador:

1. Flat
2. Aumentar os graves
3. Aumentar os agudos
4. Aumento de graves e agudos

ESPAÑOL

Preconfiguraciones de ecualizador

Presione el botón Ecualizador para recorrer los valores preestablecidos del ecualizador:

1. Plano
2. Refuerzo de graves
3. Refuerzo de agudos
4. Refuerzo de graves + agudos

SVENSK

Snabbval för frekvensutjämning

Tryck på equalizerknappen för att gå igenom snabbvalen för EQ:

1. Jämn
2. Bas-boost
3. Diskant-boost
4. Bas- och diskant-boost

DANSK

Forudindstillede equalizer indstillinger

Druk op de knop Equalizer voor het doorlopen van zes fabrieksinstellingen:

1. Plat
2. Extra basgeluid
3. Extra hoge tonen
4. Extra basgeluid + hoge tonen

NEDERLANDS

Audiovoorinstellingen van equalizer

Druk op de knop Equalizer voor het doorlopen van zes fabrieksinstellingen:

1. Plat
2. Extra basgeluid
3. Extra hoge tonen
4. Extra basgeluid + hoge tonen

Troubleshooting

No sound

- Check that the headset volume control is turned up.
- Check that the transmitter power and optical cables are properly connected.
- Check that the headset is powered on. The LED on the left ear cup should be flashing.
- Check if the Power LED on the transmitter is on solid. If the LED is slowly pulsing, it indicates that the transmitter isn't communicating with the headset. If the headset is on solid and the transmitter LED is slowly pulsing, then the headset and transmitter need to be "paired" as described in the section "Pairing the Headset and Transmitter" (see pg 4).

Audio Drops, Popping or Clicking Sounds

Audio dropouts, popping or clicking sounds on the headset are caused by poor reception. This can occur when:

- The headset and transmitter are out of range. For best performance, move within 20 feet from the transmitter.
- There's a wall or other large object between the headset and transmitter.
- The transmitter is in a bad location that is interfering with the antenna.
- A wireless base station or wireless LAN are causing a lot of RF activity that's blocking the RF signal from the transmitter. The transmitter should be moved at least 5 feet away from a wireless router or gaming console.

Voice Chat Drops

- Most in-game voice chat drops are simply caused by network performance or "lag". Usually they subside after a few moments so please be patient. In extreme cases, you may have to leave a game and return to reset the chat function.
- If you use a wireless internet connection, low signal strength from your modem/router can make the voice chat malfunction. A wired connection from your modem/router to your console is recommended for best results.

Technical Specifications

Headset

- 50mm diameter speakers with neodymium magnets
- Game audio frequency response: 20Hz - 20kHz, >120dB SPL @ 1kHz
- Condenser microphone frequency response: 50Hz - 15kHz
- Game audio Dual Band WiFi Digital 2.4GHz/5.8GHz RF wireless
- Headphone amplifier: Stereo 27mW/ch, THD <1%
- Operates on (2) AAA batteries or (2) AAA rechargeable NiMH batteries
- Automatic shut down after approx 5 minutes of carrier loss or audio silence to conserve battery power
- Battery booster circuit extends battery life for up to 15 hours

Transmitter

- Dual Band Digital WiFi Digital 2.4GHz/5.8GHz wireless transmission with up to 30 foot range
- Frequency response: 20Hz - 20kHz
- Optical TOSLINK digital audio input compatible with 48kHz digital audio stream
- Optical TOSLINK digital audio output pass-through of digital input stream
- Stereo 3.5mm analog input jack
- Maximum analog input level: 2Vpp (700mV rms)
- USB Power – (5V DC @ 350mA max)

Safety Notice / Avis de sécurité

To avoid potential damage to the device, always disconnect all cables before transporting it.

WARNING: Permanent hearing damage can occur if a headset is used at high volumes for extended periods of time, so it is important to keep the volume at a safe level. Over time, your ears adapt to loud volume levels, so a level that may not cause initial discomfort can still damage your hearing. If you experience ringing in your ears after listening with the headset, it means the volume is set too loud.

The louder the volume is set, the less time it takes to affect your hearing. So, please take care to listen at moderate levels.

- Before placing a headset on your ears, turn the volume down completely, then slowly increase it to a comfortable level.
- Turn down the volume if you can't hear people speaking near you.
- Avoid turning up the volume to block out noisy surroundings.

FRANCAIS

Consigne de sécurité: Pour éviter un endommagement potentiel sur l'appareil, veuillez à toujours débrancher tous les câbles avant de le déplacer.

MISE EN GARDE: Des dommages auditifs permanents peuvent se produire si le casque est utilisé à des volumes élevés pendant de très longues périodes de temps, par conséquent il est important de maintenir le volume à un bon niveau. Au fil du temps, vos oreilles s'adaptent aux volumes élevés, de sorte qu'un niveau qui n'est pas de nature à causer initialement de l'inconfort peut toujours finir par endommager votre audition. S'il y a un écho dans vos oreilles après avoir utilisé le casque, cela signifie que le volume est trop élevé. Plus le volume est réglé haut, moins de temps ça prend pour affecter votre audition. De grâce, veuillez prendre soin de faire l'écoute à des niveaux modérés.

- Avant de placer un casque à vos oreilles, baissez totalement le volume, puis augmentez-le doucement jusqu'à un niveau confortable.
- Baissez le volume si vous ne pouvez pas entendre les voix des gens qui sont autour de vous.
- Évitez d'augmenter le volume pour bloquer le bruit ambiant.

DEUTSCH

Sicherheitshinweis: Um mögliche Schädigungen des Gerätes zu vermeiden, trennen Sie vor einem Transport immer alle Kabel.

WARNUNG: Es kann ein dauerhafter Hörschaden entstehen, wenn ein Headset über einen längeren Zeitpunkt bei hoher Lautstärke verwendet wird, daher ist es wichtig, die Lautstärke auf einem vernünftigen Pegel zu halten. Mit der Zeit gewöhnen sich die Ohren an hohe Lautstärken; das führt dazu, dass eine Lautstärke, die kein anfängliches Unbehagen verursacht, trotzdem Ihr Gehör schädigen kann. Wenn Sie ein Klingeln in Ihren Ohren wahrnehmen, nachdem Sie mit dem Headset Musik gehört haben, bedeutet dies, dass die Lautstärke zu hoch war. Je höher die Lautstärke eingestellt wird, desto weniger Zeit benötigt es, bis Ihr Gehör beeinträchtigt wird. Achten Sie deshalb bitte darauf, in einer vernünftigen Lautstärke zu hören.

- Bevor Sie das Headset aufsetzen, drehen Sie die Lautstärke ganz nach unten und dann langsam etwas lauter auf ein angenehmes Level.
- Drehen Sie die Lautstärke niedriger, wenn Sie die Leute um sich herum nicht mehr verstehen.
- Vermeiden Sie es, die Lautstärke höher zu drehen, um den Lärm um Sie herum auszuschalten.

ITALIANO

Avviso di sicurezza: Per evitare danni al dispositivo, scollegare sempre i cavi prima del trasporto.

AVVERTENZA: se la cuffia viene utilizzata ad alto volume per lunghi periodi di tempo, potrebbe causare danni all'udito. Pertanto mantenere il volume a livelli accettabili. Nel tempo, le orecchie potrebbero adattarsi al volume alto, pertanto un livello che non causa fastidio all'inizio potrebbe comunque danneggiare l'udito. Se si avvertono ronzii nelle orecchie dopo aver utilizzato la cuffia, significa che il volume impostato è troppo alto. Più il volume è alto, minor tempo sarà necessario per danneggiare l'udito. Pertanto, impostare volumi moderati.

- Prima di indossare le cuffie, abbassare il volume e quindi alzarlo fino a raggiungere un livello accettabile
- Abbassare il volume se non si riesce a sentire la voce delle persone nelle vicinanze.
- Evitare di alzare il volume per estraniarsi da luoghi rumorosi.

PORTUGUÊS

Aviso sobre Segurança: Para evitar danos potenciais no dispositivo, desconecte sempre todos os cabos antes de o transportar.

AVISO: Poderão ocorrer danos auditivos permanentes se forem usados uns auscultadores com o volume elevado durante longos períodos de tempo, pelo que é importante manter o volume num nível seguro. Ao longo do tempo, os seus ouvidos adaptar-se-ão aos níveis de volume elevados, pelo que estes, ainda que não causem desconforto inicial, poderão, mesmo assim, prejudicar a sua audição. Se ouvir campainhas depois de ter estado a usar os auscultadores, isso significa que o volume está demasiado alto. Quanto mais alto o volume, menos tempo levará a afectar a sua audição. Portanto, tenha o cuidado de usar níveis de volume moderados.

- Antes de colocar os auscultadores nos ouvidos, diminua o volume para o mínimo; depois, aumente-o lentamente até um nível confortável.
- Diminua o volume se não conseguir ouvir as pessoas a falar perto de si.
- Evite aumentar o volume para o sobrepor a ambientes ruidosos

ESPAÑOL

Advertencia de seguridad: Para evitar que el equipo sufra daños potenciales, desconecte siempre todos los cables antes de moverlo de lugar.

ADVERTENCIA: Si los auriculares se utilizan a volúmenes altos durante períodos prolongados, pueden provocar la pérdida permanente de la audición; por eso es importante mantener el volumen en un nivel seguro. Con el tiempo, sus oídos se acostumbran a los volúmenes altos, por lo que incluso un nivel de volumen que inicialmente no le haga sentir molestias podría afectar su audición. Si siente un pitido en los oídos después de haber usado los auriculares, significa que el nivel al que está ajustado el volumen es demasiado alto. Cuanto más alto ajuste el volumen, más pronto afectará su audición. Por lo tanto, preste atención al volumen y ajústelo a niveles moderados.

- Antes de colocarse los auriculares, baje completamente el volumen y, una vez puestos, suba el volumen lentamente hasta el nivel que le resulte cómodo.
- Si no puede oír las voces de otras personas a su alrededor, baje el volumen.
- Evite subir el volumen para contrarrestar los ruidos exteriores

SVENSK

Säkerhetsföreskrifter: För att undvika att skada enheten, koppla alltid ur alla kablar innan du flyttar på den.

WARNING! Permanenta hörselskador kan uppstå om headsetet används med hög volym under en längre tid. Det är viktigt att hålla ljudet på en säker nivå. Dina öron anpassar sig till höga ljudnivåer om de utsätts för detta under en längre tid. En ljudnivå som inte upplevs som obekvämt kan således fortfarande skada din hörsel. Om du upplever att det ringar i dina öron efter att du använt headsetet betyder det att ljudnivån är för hög. Ju högre du ställer in volymen, desto kortare tid tar det för din hörsel att skadas. Var försiktig och lyssna på en rimlig ljudnivå.

- Innan du sätter på dig headsetet, skruva ner volymen helt för att sedan sakta och kontrollerat skruva upp den till en behaglig nivå.
- Skruva ner volymen om du inte kan höra personer som pratar bredvid dig.
- Undvik att skruva upp volymen för att stänga ute oönskade ljud i din omgivning.

DANSK

Sikkerhedsnotits: Undgå mulig skade på anordningen ved altid at fraslutte alle kabler før transport.

ADVARSSEL: Permanent høreskade er mulig, hvis et headset bruges ved høj lydstyrke i længere tid, så det er vigtigt at holde lydstyrken nede på et sikkert niveau. Med tiden vil dine ører tilpasse sig højere lydniveauer, så et niveau som ikke føles ubehageligt i begyndelsen, kan stadigt beskadige din hørelse. Hvis du oplever ringen for ørene efter du har brugt dit headset, betyder det, at lydstyrken er for høj. Jo højere lyden er sat, jo kortere tid tager det at påvirke din hørelse. Så sørg venligst for at lytte ved et moderat niveau.

- For du tager dit headset på, skal du skrue helt ned for lyden og så langsomt skrue op igen til et behageligt niveau.
- Skru ned for lyden hvis du ikke kan høre andre, der snakker i nærheden.
- Undgå at skrue op for lyden for at lukke støj fra omgivelserne ude.

NEDERLANDS

Veiligheidsmededeling: Koppel altijd alle kabels van het apparaat los tijdens vervoer om beschadiging van het apparaat te voorkomen.

WAARSCHUWING: Er kan onherstelbaar gehoorverlies ontstaan als een headset langdurig met hoog volume worden gebruikt. Daarom is het belangrijk om het volume op een veilig niveau te houden. De oren raken na verloop van tijd gewend aan hoge volumeniveaus zodat een niveau dat niet meteen ongemak veroorzaakt het gehoor toch kan beschadigen. Als uw oren na luisteren met de headset suizen, betekent dit dat het volume te hoog is ingesteld. Hoe hoger het volume, des te sneller het gehoor beschadigd raakt. Luister daarom bij voorkeur met een gematigd volumeniveau.

- Zet voordat u een headset opzet eerst het volume helemaal omlaag en verhoog dit dan langzaam tot een comfortabel niveau.
- Verlaag het volume als u mensen in de buurt niet kunt horen praten.
- Maak er geen gewoonte van het volume te verhogen om omgevingslawaai buiten te sluiten.

Manufacturer: Voyetra Turtle Beach
Manufacturers Address: 150 Clearbrook Rd. Suite 162, Elmsford, NY 10523
Product Name: Ear Force X42
Type of Product: Wireless Headset
Model Number(s): TBS-2270-01
Year of Manufacture: 2011

We, Voyetra Turtle Beach, Inc. of Elmsford, New York, declare under our own responsibility that the above-referenced product complies with the following directives and standards:

Low Voltage Directive 2006/95/EC
EN 50332-2:2003
EN 60950-1:2006+A11:2009

Electromagnetic Compatibility Directive 1999/5/EC
ESTI EN 301 489-1 V1.8.1 (2008)
ESTI EN 301 489-3 V1.4.1 (2002)
ESTI EN 301 489-17 V2.1.1 (2009)

R&TTE Directive 1999/5/EC
ESTI EN 300 328 V1.7.1 (2006-10)
ESTI EN 300 440-1 V1.4.1 (2008-05)
ESTI EN 300 440-2 V1.2.1 (2008-05)

All test reports have been reviewed and approved with a Positive Opinion from the following Notified Bodies:

Bay Area Compliance Laboratories, Corp (Shenzhen)
6/F, the 3rd Phase of WanLi Industrial Building
ShiHua Road, FuTian Free Trade Zone, Shenzhen, Guangdong, China
Tel: +86-755-33320018, Fax: +86-755-33320008, Web: baclcorp.com

Shenzhen EBO Technology Co., Ltd.
No. 710 Yihua Building, Futian District, Shenzhen, China 518040
Tel: +86-755-29451282 Fax: 86-755-83709189 Web: ebotech.cn

The technical documentation required by this Directive is maintained at the corporate headquarters of Voyetra Turtle Beach, 150 Clearbrook Road. Suite 162, Elmsford, New York, 10562.

Authorized Person:



Date: 11/17/11

Printed Name: Frederick Romano
Title: Executive Vice President

Product Name: Ear Force X42
Model Number(s): TBS-2270-01
FCC Rules: FCC CFR Title 47 Part 15 Subpart B: 2009 CLASS B
FCC CFR Title 47 Part 15 Subpart C: 2008

Operating Environment: **GENERAL OFFICE AND HOME USE**

FCC COMPLIANT STATEMENT

This device complies with part 15 of the FCC rules. Operation is subjected to the following conditions:

- (1) This device may not cause harmful interference, and
- (2) This device must accept any interference received including interference that may cause undesired operation.

INFORMATION TO USER

This equipment has been tested and found to comply with the limits for a Class B digital device, pursuant to Part 15 of FCC rules. These limits are designed to provide reasonable protection against harmful interference in a residential installation. This equipment generates, uses and can radiate radio frequency energy and, if not installed and used in accordance with the instructions, may cause harmful interference to radio communications. However, there is no guarantee that interference will not occur in a particular installation. If this equipment does cause harmful interference to radio or television reception, which can be determined by turning the equipment off and on, the user is encouraged to try to correct the interference by one or more of the following measures:

- 1) Reorient or relocate the receiving antenna.
- 2) Increase the separation between the equipment and receiver.
- 3) Connect the equipment into an outlet on a circuit different from that to which the receiver is connected.
- 4) Consult the dealer or an experienced radio/TV technician for help.

The user's manual or instruction manual for an intention or unintentional radiator shall caution the user that the changes or modifications not expressly approved by the party responsible for compliance could void the user's authority to operate the equipment.

WARNING: Changes or modifications made to this equipment not expressly approved by VOYETRA TURTLE BEACH, INC. may void user's authority to operate this equipment.

Limited Warranty for Turtle Beach Products

Voyetra Turtle Beach, Inc. ("VTB") warrants to the original end-user purchaser ("Purchaser") that the retail Turtle Beach hardware product herein ("Product") will be free of defects in materials and workmanship for a period of one year from the date of purchase by the Purchaser ("Warranty Period"). Any Extended Warranty or Service Plans purchased through a Retail store are not honored by VTB. The Warranty refers to the repair/replacement of a defective product during this period and not a refund.

This limited warranty extends only to the Purchaser and is not transferable or assignable to any subsequent purchaser. This limited warranty is applicable only in the country or territory where the Product was purchased from an authorized VTB retailer and does not apply to a Product that has been purchased as used or refurbished (except refurbished by VTB) or was included as part of a non-VTB product.

WARRANTY SERVICE

In the USA and CANADA Warranty Service is provided by our TURTLE BEACH OFFICES and in all other Countries it is provided by our local International Distributors.

VTB does not warrant uninterrupted or error-free operation of the Product and is under no obligation to support the Product for all computer operating systems or future versions of such operating systems.

If a defect should occur during the Warranty Period, Purchaser must contact VTB to obtain a Return Merchandise Authorization ("RMA") number. Purchaser will be responsible for shipping costs incurred in returning the defective Product to an authorized VTB service center, or to the repair facility located at VTB's corporate headquarters. A copy of the dated proof of purchase and a description of the problem must be included with the defective Product. VTB will not be responsible for other products or accessories included with the defective Product sent to VTB. The RMA number must be clearly indicated on the outside of the package. Packages without an RMA number will be refused by VTB or its representatives and returned to sender at the sender's expense.

In the event of a defect, Purchaser's sole and exclusive remedy, and VTB's sole liability, is expressly limited to the correction of the defect by adjustment, repair, or replacement of the Product at VTB's sole option and expense. VTB owns all Products it has replaced and all parts removed from repaired Products. VTB uses new and reconditioned parts made by various manufacturers in performing warranty repairs and building replacement products. If VTB repairs or replaces a product, the original Warranty Period is not extended, however, VTB warrants that repaired or replacement parts will be free from defects in material and workmanship for a period of thirty (30) days from the date of repair or replacement, or for the remainder of the Warranty Period, whichever is greater.

This warranty does not apply to any Product that has had its serial number altered, removed or defaced, or any Product damage caused by shipping, improper storage, accident, problems with electrical power, abuse, misuse, neglect, ordinary wear, acts of God (e.g. flood), failure to follow directions, improper maintenance, use not in accordance with product instructions, unauthorized modification or service of the Product or damage resulting from the use of the Product with hardware, software or other products not provided by or specifically recommended by VTB.



THIS LIMITED WARRANTY IS PURCHASER'S SOLE AND EXCLUSIVE REMEDY AND IS IN LIEU OF ALL OTHER WARRANTIES, EXPRESS OR IMPLIED. TO THE EXTENT PERMITTED BY APPLICABLE LAW, VTB HEREBY DISCLAIMS THE APPLICABILITY OF ANY IMPLIED WARRANTY OF MERCHANTABILITY, FITNESS FOR A PARTICULAR PURPOSE OR USE FOR THE PRODUCT. IF SUCH A DISCLAIMER IS PROHIBITED BY APPLICABLE LAW, THE IMPLIED WARRANTY IS LIMITED TO THE DURATION OF THE FOREGOING LIMITED WRITTEN WARRANTY.

IN NO EVENT SHALL VTB BE LIABLE FOR ANY INDIRECT, INCIDENTAL, SPECIAL, PUNITIVE OR CONSEQUENTIAL DAMAGES, OR DAMAGES, INCLUDING BUT NOT LIMITED TO ANY LOST PROFITS, DATA, OR LOSS OF USE, ANY THIRD PARTY CLAIMS, AND ANY INJURY TO PROPERTY OR BODILY INJURY (INCLUDING DEATH) TO ANY PERSON, ARISING FROM OR RELATING TO THE USE OF THIS PRODUCT OR ARISING FROM BREACH OF THE WARRANTY, BREACH OF CONTRACT, NEGLIGENCE, TORT, OR STRICT LIABILITY, EVEN IF VTB HAS BEEN ADVISED OF THE POSSIBILITY OF SUCH DAMAGES.

This warranty supersedes all prior agreements or understandings, oral or written, relating to the Product, and no representation, promise or condition not contained herein will modify these terms. Some states do not allow the exclusion or limitation of incidental or consequential damages, so the above exclusion or limitation may not apply to you. This warranty gives you specific legal rights. You may also have other rights, which vary from state to state. Any action or lawsuit for breach of warranty must be commenced within eighteen (18) months following the purchase of the Product.

EXCLUSIONS FROM LIMITED WARRANTY:

This Limited Warranty shall not apply and VTB has no liability under this Limited Warranty if the Turtle Beach Product:

- is used for commercial purposes such as "LAN Centers" (including rental or lease);
- is modified or tampered with;
- is damaged by Acts of God, power surge, misuse, abuse, negligence, accident, wear and tear, mishandling, misapplication, or other causes unrelated to defective materials or workmanship;
- serial number is defaced, altered or removed;
- is not used in accordance with the documentation and use instructions; or
- is repaired, modified or altered by other than authorized repair centers.
- product is no longer available because it was discarded.

Federal Communications Commission Interference Statement

This equipment has been tested and found to comply with the limits for a Class B digital device, pursuant to part 15 of the FCC Rules. These limits are designed to provide reasonable protection against harmful interference in a residential installation. This equipment generates, uses and can radiate radio frequency energy and, if not installed and used in accordance with the instructions, may cause harmful interference to radio communications. However, there is no guarantee that interference will not occur in a particular installation. If this equipment does cause harmful interference to radio or television reception, which can be determined by turning the equipment off and on, the user is encouraged to try to correct the interference by one or more of the following measures:

- Reorient or relocate the receiving antenna.
- Increase the separation between the equipment and receiver.
- Connect the equipment into an outlet on a circuit different from that to which the receiver is connected.
- Consult the dealer or an experienced radio/TV technician for help.

FCC Caution:

Any changes or modifications not expressly approved by the grantee of this device could void the user's authority to operate the equipment.

RF Exposure Warning:

Headset:

The equipment complies with FCC RF exposure limits set forth for an uncontrolled environment. The equipment must not be co-located or operating in conjunction with any other antenna or transmitter.

Transmitter Box:

This equipment must be installed and operated in accordance with provided instructions and the antenna(s) used for this transmitter must be installed to provide a separation distance of at least 20 cm from all persons and must not be co-located or operating in conjunction with any other antenna or transmitter. End-users and installers must be provided with antenna installation instructions and transmitter operating conditions for satisfying RF exposure compliance.

CANADA, INDUSTRY CANADA (IC) NOTICES

This Class B digital apparatus complies with Canadian ICES-003 and RSS-210. Operation is subject to the following two conditions: (1) this device may not cause interference, and (2) this device must accept any interference, including interference that may cause undesired operation of the device.

Radio Frequency (RF) Exposure Information:

Headset:

The radiated output power of the Wireless Device is below the Industry Canada (IC) radio frequency exposure limits. The Wireless Device should be used in such a manner such that the potential for human contact during normal operation is minimized. This device has also been evaluated and shown compliant with the IC RF Exposure limits under portable exposure conditions. (antennas are less than 20 cm of a person's body).

Transmitter:

The radiated output power of the Wireless Device is below the Industry Canada (IC) radio frequency exposure limits. The Wireless Device should be used in such a manner such that

the potential for human contact during normal operation is minimized. This device has also been evaluated and shown compliant with the IC RF Exposure limits under mobile exposure conditions. (antennas are greater than 20cm from a person's body).

This device has been certified for use in Canada. Status of the listing in the Industry Canada's REL (Radio Equipment List) can be found at the following web address: <http://www.ic.gc.ca/app/sitt/reltel/srch/nwRdSrch.do?lang=eng>
Additional Canadian information on RF exposure also can be found at the following web address: <http://www.ic.gc.ca/eic/site/smt-gst.nsf/eng/sf08792.html>

Canada, avis d'Industry Canada (IC)

Cet appareil numérique de classe B est conforme aux normes canadiennes ICES-003 et RSS-210. Son fonctionnement est soumis aux deux conditions suivantes : (1) cet appareil ne doit pas causer d'interférence et (2) cet appareil doit accepter toute interférence, notamment les interférences qui peuvent affecter son fonctionnement.

Informations concernant l'exposition aux fréquences radio (RF)

Headset:

La puissance de sortie émise par l'appareil de sans fil Dell est inférieure à la limite d'exposition aux fréquences radio d'Industry Canada (IC). Utilisez l'appareil de sans fil Dell de façon à minimiser les contacts humains lors du fonctionnement normal. Ce périphérique a également été évalué et démontré conforme aux limites d'exposition aux RF d'IC dans des conditions d'exposition à des appareils portables (les antennes sont moins de 20 cm du corps d'une personne).

Transmitter:

La puissance de sortie émise par l'appareil de sans fil Dell est inférieure à la limite d'exposition aux fréquences radio d'Industry Canada (IC). Utilisez l'appareil de sans fil Dell de façon à minimiser les contacts humains lors du fonctionnement normal. Ce périphérique a également été évalué et démontré conforme aux limites d'exposition aux RF d'IC dans des conditions d'exposition à des appareils mobiles (les antennes se situent à moins de 20 cm du corps d'une personne).

Ce périphérique est homologué pour l'utilisation au Canada. Pour consulter l'entrée correspondante à l'appareil dans la liste d'équipement radio (REL - Radio Equipment List) d'Industry Canada rendez-vous sur: <http://www.ic.gc.ca/app/sitt/reltel/srch/nwRdSrch.do?lang=eng>
Pour des informations supplémentaires concernant l'exposition aux RF au Canada rendez-vous sur: <http://www.ic.gc.ca/eic/site/smt-gst.nsf/eng/sf08792.html>

This product is CE marked according to the provisions of the Low Voltage Directive (2006/95/EC), R&TTE Directive (1999/5/EC) and EMC Directive (1989/5/EC).

Frequency Range: 2.404-2.476GHz / 5.160-5.340GHz

• Grantee Code/Reg Number: XGB/GC229855 • Voyetra Turtle Beach, Inc.



IC: 3879A-2270
IC: 3879A-2271

DESIGNED AND ENGINEERED BY TURTLE BEACH IN NEW YORK, USA

Copyright © 2012 Voyetra Turtle Beach, Inc. (VTB, Inc.) All rights reserved. No part of this guide may be reproduced without permission. Turtle Beach, the Turtle Beach Logo, Voyetra, Ear Force, Chat Boost, Engineered For Gaming and the Dual Band logo are either trademarks or registered trademarks of VTB, Inc. XBOX, XBOX 360 and XBOX LIVE are registered trademarks of Microsoft Corporation. Dolby and the double-D symbol are trademarks of Dolby Laboratories. All other trademarks are properties of their respective companies and are hereby acknowledged. Assembled in China. **PATENTS PENDING**



For more products, accessories and general product information, please visit
TurtleBeach.com

For warranty information and product support, please visit
TurtleBeach.com/support

FRANÇAIS

Pour plus d'informations sur les produits et accessoires, veuillez visiter le site TurtleBeach.com
Pour toute question de garantie ou d'assistance technique, veuillez visiter la page TurtleBeach.com/support

DEUTSCH

Weitere Hinweise zu Produkten, Zubehör und allgemeine Produktinformationen finden Sie unter: TurtleBeach.com
Informationen über Garantieleistungen und Produkt-Support finden Sie unter: TurtleBeach.com/worldwide

ITALIANO

Per ulteriori prodotti, accessori e informazioni generali sul prodotto, visitare: TurtleBeach.com
Per informazioni sulla garanzia e supporto del prodotto, visitare: TurtleBeach.com/worldwide

PORTUGUÊS

Para mais produtos, acessórios e informações gerais do produto, visite: TurtleBeach.com
Para informações sobre garantia e suporte ao produto, visite: TurtleBeach.com/worldwide

ESPAÑOL

Podrá encontrar más productos, accesorios e información general en TurtleBeach.com
Información sobre la garantía y apoyo técnico en: TurtleBeach.com/support

SVENSK

För ytterligare produkter, tillbehör och allmän produktinformation, vänligen besök: TurtleBeach.com
För information om garanti och produktsupport, vänligen besök: TurtleBeach.com/support

DANSK

For flere produkter, tilbehør og generel produkt information, besøg venligst: TurtleBeach.com
For garantioplysninger og produktsupport, kan du besøge: TurtleBeach.com/support

NEDERLANDS

Bezoek voor meer producten, accessoires en algemene productinformatie: TurtleBeach.com
Voor garantie-informatie en productondersteuning kunt u terecht op: TurtleBeach.com/support

Notes
