



---

# User's Manual

[www.vtechphones.com](http://www.vtechphones.com)



Models:  
mi6897/6877

**5.8**  
GHz  
DIGITAL

# Table of contents

<b>Getting started</b> . . . . .	<b>4</b>	Flash function . . . . .	17
Parts checklist for mi6897 . . . . .	4	Mute . . . . .	18
Parts checklist for mi6877 . . . . .	5	Intercom . . . . .	18
Installation . . . . .	6	Redial . . . . .	18
Choose a location . . . . .	6	Call forward . . . . .	19
Install handset battery . . . . .	6	Call transfer . . . . .	20
Connect power to telephone base/ handset chargers.	7	Conference call . . . . .	20
Connect to phone line . . . . .	7	Intercom/find handset . . . . .	20
Check battery indicator . . . . .	8	Directory . . . . .	22
Check for dial tone . . . . .	8	Store a new entry . . . . .	22
If you subscribe to DSL service (optional). . . . .	9	Characters by number . . . . .	23
Belt clip (optional) . . . . .	9	Review and dial entries . . . . .	24
Registration . . . . .	11	Edit a directory entry . . . . .	24
To register a handset . . . . .	11	Delete a directory entry . . . . .	25
Registration . . . . .	12	Caller ID . . . . .	26
To de-register all handsets. . . . .	12	Caller ID - call waiting with CID . . . . .	26
Handset layout . . . . .	13	Review caller ID . . . . .	27
Telephone base layout . . . . .	14	Store caller ID in your directory . . . . .	27
<b>Basic operation</b> . . . . .	<b>15</b>	Dial from caller ID . . . . .	29
Visual indicators . . . . .	15	Delete a caller ID record . . . . .	29
Handset icons . . . . .	15	Delete all caller ID entries . . . . .	29
Telephone base icons . . . . .	15	Telephone settings . . . . .	30
Telephone base LEDs . . . . .	16	Ringer volume . . . . .	30
Handset LEDs . . . . .	16	Ringer tone . . . . .	30
Telephone operation . . . . .	17	Key tone . . . . .	30
Making calls . . . . .	17	Language . . . . .	31
Answering calls . . . . .	17	Clear voicemail. . . . .	31
Adjusting handset volume . . . . .	17	Dial type . . . . .	31

## Table of contents

Answering system operation . . . . .	32	Replace the handset battery. . . . .	45
Turn the answering feature on and off. . . . .	32	<b>Additional information . . . . .</b>	<b>46</b>
Day and time announcements . . . . .	32	Troubleshooting . . . . .	46
To check day and time . . . . .	33	Troubleshooting . . . . .	53
Outgoing announcement . . . . .	34	Maintenance . . . . .	54
Record outgoing announcement. . . . .	34	Warranty . . . . .	54
Listen to outgoing announcement . . . . .	35	Warranty . . . . .	55
Delete outgoing announcement . . . . .	35	Important safety instructions . . . . .	56
Message playback . . . . .	35	FCC, ACTA and IC regulations . . . . .	57
Announcements . . . . .	36	The RBRC® Seal . . . . .	58
Options during playback . . . . .	36	Technical specifications . . . . .	59
Delete all messages . . . . .	36	Index . . . . .	60
Record and play memos. . . . .	37		
Remote access code. . . . .	37		
Set remote access code . . . . .	38		
Remote operation . . . . .	38		
Message alert . . . . .	40		
Announcement only mode . . . . .	41		
Turn announcement only mode on or off . . . . .	41		
Record the announcement only message. . . . .	41		
Call screening . . . . .	42		
Number of rings . . . . .	42		
Menu features . . . . .	34		
Message window displays . . . . .	43		
Headset operation . . . . .	44		
Headset jack . . . . .	44		
Batteries . . . . .	45		
Battery care and performance. . . . .	45		

# NEED HELP?

This manual has all the feature operations and troubleshooting you need to install and operate your new VTech telephone. Please take the time to review thoroughly to ensure proper installation so you can enjoy the benefits of this VTech innovative and feature rich product. You can also visit our website at [www.vtechphones.com](http://www.vtechphones.com) for support, shopping, and everything new at VTech. In Canada, please visit [www.vtechcanada.com](http://www.vtechcanada.com).

Call VTech toll free from the US at 1-800-595-9511  
Call VTech toll free from Canada at 1-800-267-7377

## note

- Before using this telephone, you must read **Important Safety Instructions** on page 56.

## Getting started

### Parts checklist for mi6897

1. Telephone base
2. Handsets (3)
3. Charger power adaptors (2)
4. Chargers (2)
5. Telephone line cord
6. Belt clips (3)
7. Batteries (3)
8. Quick start guide
9. Base power adaptor
10. Wall mount bracket
11. User's manual

To purchase replacement batteries, visit us on the web at [www.vtechphones.com](http://www.vtechphones.com) or call VTech Communications, Inc. at 1-800-595-9511. In Canada, contact VTech Telecommunications Canada Ltd. at [www.vtechcanada.com](http://www.vtechcanada.com) or 1-800-267-7377.

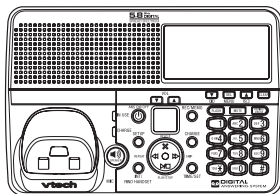

1. Telephone base



2. Handsets (3)

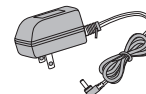

3. Charger power adaptors (2)



4. Chargers (2)

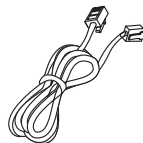

5. Telephone line cord



6. Belt clips (3)

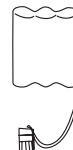

7. Batteries (3)

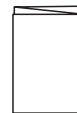

8. Quick start guide

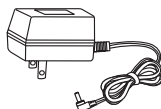

9. Base power adaptor



10. Wall mount bracket



11. User's manual

## Getting started

### Parts checklist for mi6877

1. Telephone base
2. Handset
3. Wall mount bracket
4. Telephone line cord
5. Quick start guide
6. Belt clip
7. Telephone base power adaptor
8. Battery
9. User's manual

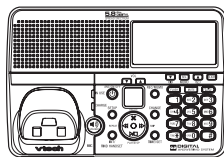

1. Telephone base



2. Handset



3. Wall mount bracket

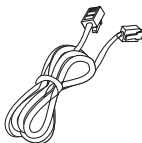

4. Telephone line cord

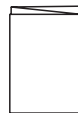

5. Quick start guide



6. Belt clip

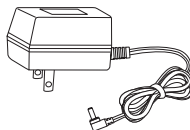

7. Telephone Base power adaptor



8. Battery



9. User's manual

## note

- Use only the VTech battery pack supplied with your phone.
- Place the handset in its telephone base when not in use to ensure optimum performance.

## Installation

### Choose a location

For optimal performance of your cordless telephone system:

1. Choose a central location for the telephone base.
2. Install your phone(s) as far away as possible from any other cordless (wireless) devices such as cordless telephones, 802.11 wireless routers (for example, WiFi), etc.
3. Install your phone(s) as far away as possible from other electronic equipment such as microwave ovens, televisions, computers, etc.
4. Install your telephone equipment away from heat sources and direct sunlight.
5. Avoid excessive moisture, dust or extreme cold.

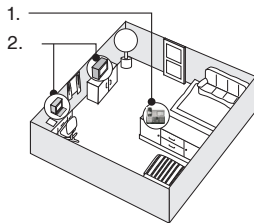

### Install handset battery

1. Align the two holes in the jack with the socket pins, then snap the plug into place according to the color-coded label.
2. Place the battery in the compartment with the wires tucked inside.
3. Replace cover by sliding it upwards until it clicks into place.
4. Be sure to charge the battery in the handset for a minimum of 16 hours before you use your phone.

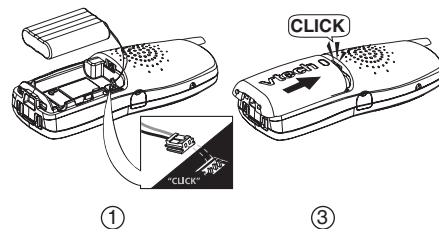

## Installation

### Connect power to telephone base/ handset chargers

1. Plug the power adapter into an electrical outlet not controlled by a wall switch, and the connector into the bottom of the telephone base.
2. Choose the location for your charger, and plug its power supply into an electrical outlet.

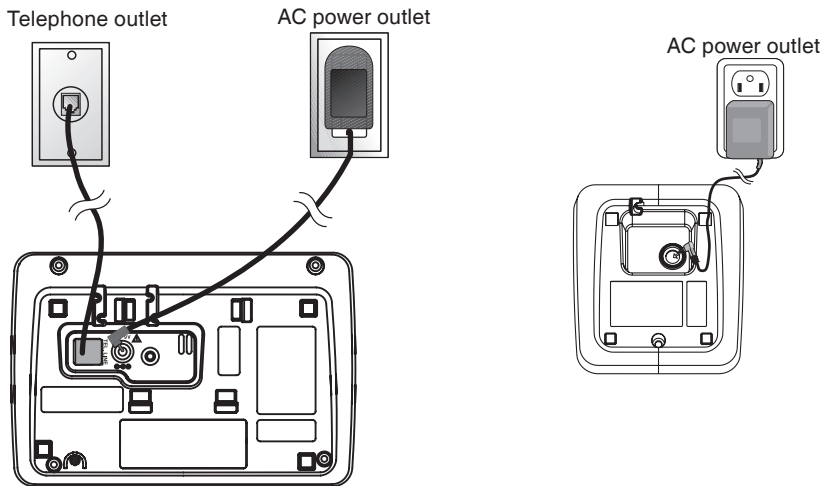

### Connect to phone line

Plug one end of the telephone line cord into the jack at the bottom of the telephone base, Then plug the other end of the cord into the wall outlet.

### note

- If the battery has not been charged, place the handset in the telephone base, and allow it to charge for at least 16 hours.
- Use only the VTech power supply provided with your telephone.



## note

- If the phone will not be used for a long period of time, remove the battery to prevent possible leakage.
- If you have any trouble installing your phone, please refer to the Troubleshooting section near the end of this manual.

## Installation

### Check battery indicator

If you see **WARNING CHECK BATTERY!** on the handset display, it indicates one of the following:

1. There is no battery in your handset. You need to install the supplied battery into your handset (see **Install handset battery** on page 6.)
2. The battery needs to be replaced.
3. The battery has been installed incorrectly. Please reinstall (see **Install handset battery**) and/or see the diagram in the battery compartment of the handset.

When in **LOW BATTERY** mode, the keypad sounds, backlighting and speakerphone features do not work. When the battery has been charged, these features will return to their normal function.

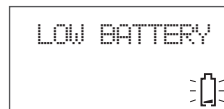

### Check for dial tone

After the battery is charged, press  on the handset. You should hear a dial tone. If not, see Troubleshooting.

## Installation

### If you subscribe to DSL service (optional)

If you hear interference during conversations and/or your caller ID features are not functioning properly, install a noise filter to the telephone line between the telephone base and the telephone line jack. Contact your DSL provider to obtain a noise filter.

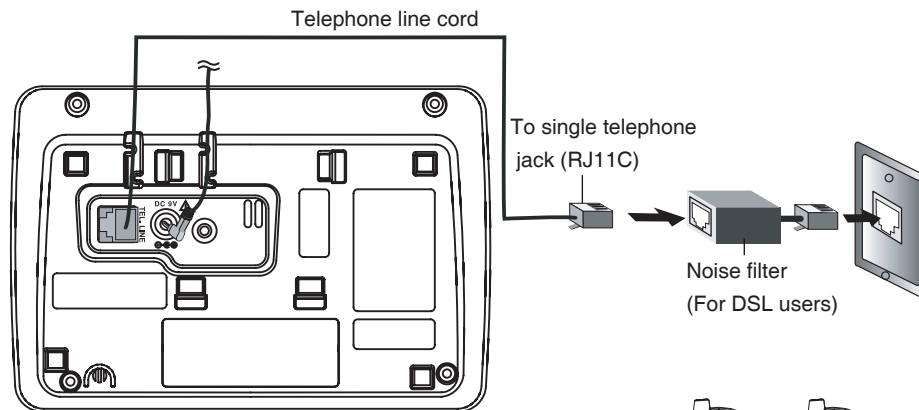

### Belt clip (optional)

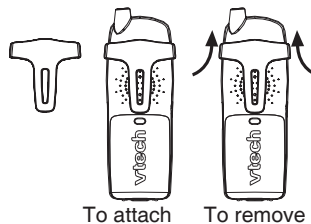

## Wall mounting (optional)

The wall mount brackets are designed for use on standard wall mount plates only.

1. Follow the instruction on page 7 to connect the power to telephone base and phone line.
2. Line up the tabs on the wall mount adapters with the holes at the bottom of the telephone base. Snap the wall mount bracket firmly in place.
3. Mount the telephone base on the wall. Position the telephone base so that the mounting studs will fit into the holes on the wall mount bracket. Slide telephone base down on the mounting studs until it locks into place.

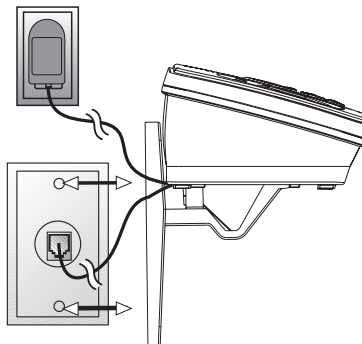

## Registration

The **mi6877** comes with one registered handset (named **Handset 1**). Additional handsets will be assigned numbers in the order they are registered (**Handset 2, 3, 4**). You can register a maximum of four handsets.

The **mi6897** comes with three registered handsets (named **Handset 1, 2, and 3**). You can register one additional handset, which will be named **Handset 4**.

Additional handsets (**mi6803**) are available from your local authorized dealers or from our website at [www.vtechphones.com](http://www.vtechphones.com) in the U.S., or [www.vtechcanada.com](http://www.vtechcanada.com) in Canada.

Up to four extension handsets can be registered with the same telephone base, and two can be in operation at the same time. Each additional handset purchased will have to be registered separately following the instruction which comes with the optional handsets.

### To register a handset

When first purchased, all accessory handsets show **NOT REGISTERED** on the screen. To register a handset:

1. Place the handset in its charger (connected to a power outlet.) If **PRESS FIND HNDST 4 SEC ON BASE** does not appear on the screen after a few seconds, lift up handset and place in the charger again.
2. On the main telephone base,
  - Press and hold **INT/FIND HANDSET** key for four seconds.
  - Release **INT/FIND HANDSET** key when **IN USE** light is on.

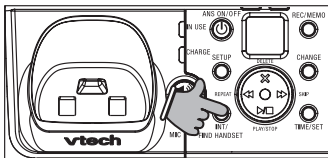

Four  
seconds  
later:

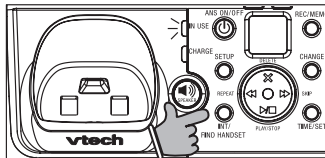

After about 10 seconds the handset will emit a tone and the handset will be assigned the lowest extension number not previously assigned to another system handset (1-4) when successfully registered. Repeat steps 1 and 2 if handset is not registered within two minutes.

[www.vtechphones.com](http://www.vtechphones.com)

### note

- When first purchased you need to charge your handsets for five minutes before registering to telephone base.
- The handset number is used as the extension number.
- If the registration is not successful lift all handsets out of their telephone base or charger and place them back in the telephone base or charger. Try the registration process again.

## note

- If de-register process does not work you may need to reset the system and try again. To reset: pick up the handset and press . Press the OFF button and place the handset back into the telephone base or charge.

## Registration

If you are replacing a handset on a system that has the maximum number of registered handsets or wish to change the assigned handset number of your registered handsets, you must first de-register the handsets, then re-register all handsets.

### To de-register all handsets

1. Press and hold **INT/FIND HANDSET** on the main telephone base for 10 seconds.
2. When the **IN USE** light starts to flash, release the **INT/FIND HANDSET** button.
3. Press and release **INT/FIND HANDSET** again. The **IN USE** light will turn off and in a few seconds, all handsets will be de-registered.
4. All handsets will show **NOT REGISTERED**.



NOT REGISTERED

## Handset layout

1. Earpiece
2. CID/▼
3. Headset jack (2.5mm)
4. Talk/flash
5. Dialing keys (0-9, \*, #)
6. Redial/pause
7. Mute/remove
8. LCD display
9. Menu/select
10. Directory/▲
11. Volume (on side of handset)
12. Off/clear
13. Speaker
14. Intercom

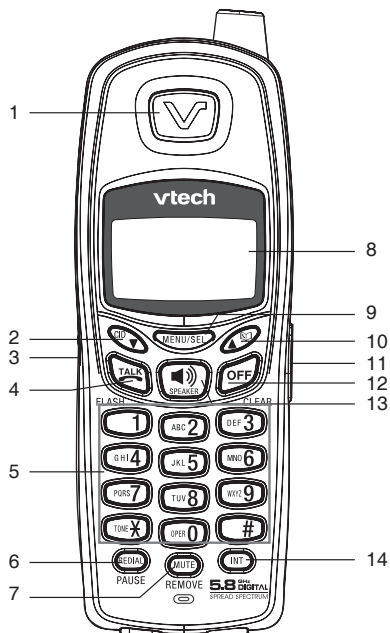

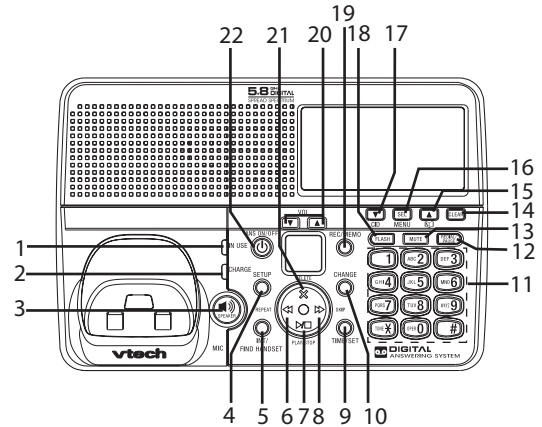

## Telephone layout

1. In use indicator
2. Charging indicator
3. Speaker
4. Setup
5. Intercom/find handset
6. Repeat
7. Play/stop
8. Skip
9. Time/set
10. Change
11. Dialing keys (0-9, \*, #)
12. Redial/pause
13. Mute
14. Clear
15. Directory
16. Sel/menu
17. Caller ID
18. Flash
19. Record/memo
20. Volume
21. Delete
22. Answer on/off



## Visual indicators

### Handset icons

Icon	Description
MUTE	<ul style="list-style-type: none"><li>• Turns on when the microphone is muted.</li></ul>
NEW	<ul style="list-style-type: none"><li>• Turns on when missed calls have not been reviewed.</li></ul>
	<ul style="list-style-type: none"><li>• Turns on when the handset ringer is off.</li></ul>
	<ul style="list-style-type: none"><li>• Low battery indicator or charging indicator.</li></ul>

### Base icons

Icon	Description
MUTE	<ul style="list-style-type: none"><li>• Turns on when the microphone is muted.</li></ul>
NEW	<ul style="list-style-type: none"><li>• Turns on when missed calls have not been reviewed.</li></ul>
	<ul style="list-style-type: none"><li>• Turns on when the telephone base ringer is off.</li></ul>



## Visual indicators

### Handset LEDs

LED	Description
 SPEAKER	<ul style="list-style-type: none"><li>On when handset speakerphone is in use.</li></ul>

### Base LEDs

LED	Description
 SPEAKER	<ul style="list-style-type: none"><li>On when base speakerphone is in use.</li></ul>
IN USE	<ul style="list-style-type: none"><li>On when the phone is being used.</li><li>Flashes when an extension phone is being used.</li></ul>
CHARGE	<ul style="list-style-type: none"><li>On when the handset is charging in the base.</li></ul>
MUTE	<ul style="list-style-type: none"><li>On when the microphone is muted.</li></ul>
ANS ON/OFF	<ul style="list-style-type: none"><li>On when the answering system is on.</li></ul>

## Telephone operation

### Making calls

#### From the Handset:

- Press **TALK** (or **SPEAKER** to use the handset speakerphone feature), then dial the phone number.

-OR-

Dial the phone number first, then press **TALK** (or **SPEAKER**).

- To end your call press **OFF** or place the handset in its base.

#### From the telephone base:

- Press **SPEAKER**. Dial the phone number.

-OR-

Dial the phone number first, then press **SPEAKER**.

- Press **SPEAKER** to end your call.

### Answering calls

#### From the Handset:

- Press **TALK**, **SPEAKER** or any dialing keys.
- To end your call press **OFF** or place the handset into its base.

#### From the telephone base:

- Press **SPEAKER** or any dialing keys.
- Press **SPEAKER** to end your call.

### Volume control

Press the **VOL** ▼ or ▲ on the handset or base to adjust listening volume. when you change the volume level, the new setting is saved. The new volume level will be applied each time you use the handset, speakerphone or headset.

### Flash function

When you subscribe to the call waiting service from your telephone company, press **TALK/FLASH** to switch to the new call when you receive a call waiting signal. Press **TALK/FLASH** again to switch back to the original call.

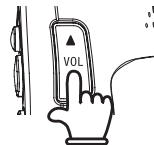

### note

- The procedure to adjust the volume is the same for the handset earpiece, speakerphone, and headset.
- Use **TALK/FLASH** to access other phone company subscriber services described by your provider.

## note

- If the redial memory is empty, and **REDIAL** is pressed, a double beep will sound.

## Telephone operation

### Redial

- When the handset is idle, press **REDIAL/PAUSE** to display the last telephone number dialed from the handset (up to 32 digits). Use **▲** or **▼** to scroll through the last five numbers dialed. When the beginning or the end of the redial list is reached, a double beep will sound.
- When the desired number is reached, press **TALK** or **SPEAKER**.
- To erase the displayed number, press **REMOVE** on the handset (or **DELETE** on the base). A confirmation beep will sound.
- Press **OFF** on the handset (or **CLEAR** on the base) to exit the redial review list.

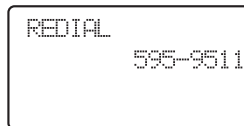

REDIAL  
595-9511

### Mute

- During a call, press the **MUTE** key to disable the microphone. You will not be heard but you will be able to hear the other person. The screen will display **MUTED** briefly:
- Press **MUTE** again to return to the normal two-way conversation. **MICROPHONE ON** will display briefly.

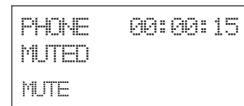

PHONE 00:00:15  
MUTED  
MUTE

### Intercom

You can have intercom conversations between system handsets or the base.

- When the handset or base are idle (off), press **INT** on the handset or **INT/FIND HANDSET** on the base, the screen will display:
- Press dialing keys to select the called handset number to be called (1-4 or 0 for the base).
- The other handset or base will ring and the screen will display (for example):

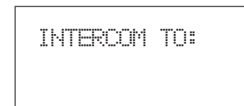

INTERCOM TO:

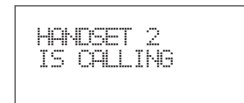

HANDSET 2  
IS CALLING

## Telephone operation

- Press **TALK**, **SPEAKER**, **INT** or any dialing key on the other handset (or **SPEAKER** or **INT/FIND HANDSET** on the base) to answer the intercom call. The screen will display:
- To end the call, press **INT**, or **OFF** on either handset (or **CLEAR** on the base), or place the handset back in its telephone base.
- If the other handset being called is out of range or on an external call, when paged, the display of the calling handset will show:

### Call forward

An external call can be forwarded from base to handset, handset to handset, or handset to base.

- If you are on an external call, you can forward the call to another handset or base by pressing and holding **INT**. The calling handset display will show **FORWARD TO** and you should input the number of the desired handset (1-4, or 0 for the base).
- The called handset or base will show **INCOMING CALL** and start ringing.
- Press **TALK**, **SPEAKER** or any of the dialing keys on the called handset (**SPEAKER** or **INT/FIND HANDSET** on the base) to answer the call.

If the forwarded call is not answered within 30 seconds, the external call will be returned to the first handset, the display will show **CALL BACK**, and ring for 30 seconds. If the returned call is not answered within 30 seconds, the external call will end automatically.

INTERCOM

INTERCOM ENDED

UNABLE TO CALL  
TRY AGAIN

FORWARD TO:

CALL BACK

## note

- For the **INT/FIND HANDSET** function to work, the system handsets need to be in idle (off) mode.

## Telephone operation

### Call transfer

An external call can be transferred from base to handset, handset to handset, or handset to base.

- The person at a handset or base can transfer an external call to another handset or base by pressing **INT (SPEAKER or INT/FIND HANDSET)** on the base). The external call is put on hold automatically.
- Select the handset number to be transferred (1-4 or 0 for the base.)
- The called handset or base will ring and the screen will show **HANDSET 1 IS CALLING**.
- Pick up the transferred call on the called handset by pressing **TALK**, **SPEAKER** or **INT**.
- The people at the two handsets/base will be able to talk to each other. Either person can hang up allowing the conversation with the external person to resume. **CALL TRANSFERRED** will briefly be displayed on the calling handset.

If the transferred call is not answered within 100 seconds, the intercom attempt will be automatically ended and the external call will return to the first handset.

### Conference call

It is possible to establish a conference call between any two handsets (or a handset and the telephone base) and the external line.

If the telephone base or a handset is already connected to the external line, the telephone base or a handset can join the call by pressing **SPEAKER** on the telephone base or **TALK** on a handset. A conference call will immediately be established. The screens will show:



PHONE 00:00:25

### Intercom/find handset

If you cannot find your handset(s) press **INT/FIND HANDSET** on the telephone base to page the handset(s) for up to 60 seconds.

- When the handset is not being used, press **INT/FIND HANDSET**.
- Press dialing keys to select the called handset number to be called.

## Telephone operation

-OR-

- Press \* or wait 3 seconds you can page all handsets
- All handsets will ring and the screen on the handsets and the telephone base will display (for example):
- To cancel the page at the handset, press , **SPEAKER** or any dial pad key (0-9, \*, #) on the handset, or press **INT/FIND HANDSET** at the base. Pressing **OFF** on a handset will silence the ringer but not cancel the page.



## PAGING ##

## note

- All handsets and the base share a common directory, stored in the base. Entries entered into one handset are available at all handsets and base, and if a directory entry is deleted, it will disappear from all handsets and base.
- While entering numbers, press and hold **REDIAL/PAUSE** to add pauses if necessary.
- If there is a duplicated number in the directory, the display will show: **ALREADY SAVED.**

## Directory

Your phone can store up to 50 entries (numbers with names) in memory. Each memory location can hold up to 32 digits for the number and 16 characters for the name.

### Store a new entry

- Press **MENU** on the handset or base.
- With **DIRECTORY** selected, press **SEL.**
- Press **▼** to select **STORE.** Press **SEL.**
- You will be prompted to **ENTER NUMBER.** Use the dialing keys to enter the number to be stored in the directory. Press **MUTE/REMOVE** on the handset (or **DELETE** on the base) to backspace and make corrections. Press **SEL** when you are done entering the phone number.
- You will then be prompted to **ENTER NAME.** Use the dialing keys to enter the name you wish to store. Press **SEL** when you are done entering the name.
- A confirmation tone will sound, and the new directory entry will briefly be displayed.
- If the directory is full, the handset will display **LIST FULL.**

ENTER NUMBER  
800-595-9511\_

ENTER NAME  
\_

LIST FULL

# Directory

## Characters by number

Pressing any particular key causes different characters to be displayed in the following order:

Key	Characters by number of key presses								
	1	2	3	4	5	6	7	8	9
1	1	#	'	,	-	.	&		
2	A	B	C	2	a	b	c		
3	D	E	F	3	d	e	f		
4	G	H	I	4	g	h	i		
5	J	K	L	5	j	k	l		
6	M	N	O	6	m	n	o		
7	P	Q	R	S	7	p	q	r	s
8	T	U	V	8	t	u	v		
9	W	X	Y	Z	9	w	x	y	z
0	0								
*	*	?	!	/	(	)	@		
#	space								



## note

- When reviewing the directory, the second line of the display will show the number, up to 16 digits. For phone numbers longer than 16 digits, only the first 13 digits will be shown. Press **\*** or **#** to scroll the phone number to see the additional digits.
- If there are no entries in the directory when it is accessed, **DIRECTORY EMPTY** will display.

## Directory

### Review and dial entries

- Press **MENU** on the handset or telephone base, with **DIRECTORY** highlighted, press **SEL**. With **REVIEW** in the first line, press **SEL**.  
- OR -  
With the handset or telephone base idle, press **▲** to enter the directory review mode. The first directory entry will be displayed.

- Scroll through the directory entries using **▲** and **▼** or enter the first character of the name to be searched (using the digit keys). Continue pressing the **▲** or **▼** keys, until you reach the desired entry.
- Press **TALK** or **SPEAKER** to dial the number.

### Edit a directory entry

- Follow the steps in **Review and dial entries** above to reach the entry to be edited.
- Press **SEL** to enter number edit mode.
- Press **MUTE/REMOVE** on the handset (or **DELETE** on the telephone base) to backspace, then press the dialing keys to correct the number. Press and hold **REDIAL/PAUSE** to add pauses if necessary.

```
> DIRECTORY  
CALL LOG
```

```
EDIT NUMBER  
800-595-9511_
```

## Directory

- Press **SEL**.
- Press **MUTE/REMOVE** on the handset (or **DELETE** on the telephone base) to backspace and use the dialing keys to enter the correct name.
- Press **SEL** when you are done editing the entry. You'll hear a confirmation tone.

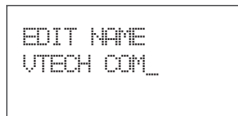

EDIT NAME  
VTECH COM\_

### Delete a directory entry

- Follow the steps in **Review and dial entries** (page 24) to reach the entry to be deleted.
- Press **MUTE/REMOVE** on the handset (or **DELETE** on the telephone base) to delete the entry. A confirmation tone will sound.
- The handset or telephone base will then advance to the next entry, if any.

## note

- Due to regional incompatibilities, CID information may not be available for every incoming call. In addition, the calling parties may intentionally block their names and/or phone numbers from being sent.
- These are subscription services provided by most regional telephone service providers. You must subscribe to these services to enjoy the benefits of these features. If you do not subscribe to CID services, you can still use your phone and the other features it offers.

## Caller ID

### Caller ID - call waiting with CID

Your phone is capable of displaying the number of the caller before the call is answered (caller ID or CID). If the number is already in the directory, the name of the caller will also be displayed. Your phone can hold up to 50 CID entries.

- The handset or base display inform you when there are calls that have not been answered by a system handset or base. These are missed calls. If you answer a call before the information appears on the screen, it will not be in the caller ID log.
- The **NEW** icon in the lower left corner indicates the call has not yet been reviewed.
- Press and hold **REMOVE** on the handset (or **DELETE** on the base) will clear all missed CID records.
- After all missed **CID** records are reviewed, the screen will show:



HANDSET 1  
5 MISSED CALLS



HANDSET 1

Your phone can also display the name and number of the call waiting caller, (call waiting caller ID,) so you can decide whether to answer the incoming call, or continue with the current conversation.

## Caller ID

### Review caller ID

When the handset or base is idle (off), press the ▼ to enter the caller id review mode.

-OR-

- With the handset or base idle (off), press **MENU**.
- Press ▼ to scroll to **CALL LOG**.
- Press **SEL**. Use ▲ and ▼ to scroll through the call log entries. When the beginning or the end of the call log is reached, a double beep will sound.
- If the call log is full, the oldest entry is deleted to make room for the new call. If the call log is empty the following message is displayed when you try to review CID records:

```
>CALL LOG
RINGER VOLUME
```

```
CALL LOG EMPTY
```

### Store caller ID in your directory

- Follow the steps in Review caller ID (above) to find the record to be stored.
- The phone number in the caller ID log was sent by the phone company. You may have to dial the number differently. Press the # key repeatedly to see the different dialing options. You can add or remove an initial 1 or the area code. The dialing options are:
- Press **SEL** to store the displayed number.
- If the caller ID record contains both name and number, the name and number will be stored after pressing **SEL**.

```
595-9511
1-595-9511
800-595-9511
1-800-595-9511
```

### note

- Press **OFF** on the handset (or **CLEAR** on the base) any time to exit the caller ID log.
- All handsets and the base share a common caller ID log, stored in the base. If a call log entry is deleted, it will disappear from all handsets and the base.

## Caller ID

- If the record does not contain a name, you will be prompted to **EDIT NAME** and the screen will show:
- If the caller ID record does not contain a number, you will be prompted to **EDIT NUMBER**, and the screen will show:
- After the entry has a name and number, press **SEL** to save. A confirmation beep will sound and the screen will display **SAVED**
- If both the name and number are missing, for example, as in a private listing, nothing will be stored, and the screen will display:
- If the number already exists in the directory, the entry will not be stored, and the screen will show:
- If the directory is full, the screen will show:

EDIT NAME  
VTech Con\_

ENTER NUMBER  
800-535-9511\_

UNABLE TO SAVE

ALREADY SAVED

LIST FULL

## Caller ID

### Dial from caller ID

- Follow the steps in **Review caller ID** (page 27) to find the entry to be dialed.
- To change how the number will be dialed, press # repeatedly to scroll through the various dialing options. The dialing options are:
- Press **TALK** or **SPEAKER** to dial the number.

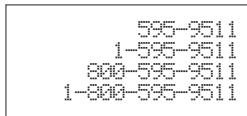

595-9511  
1-595-9511  
800-595-9511  
1-800-595-9511

- The phone number in the caller ID log was sent by the phone company. You may have to dial the number differently. Press the # key repeatedly to see the different dialing options. You can add or remove an initial 1, as well as the area code.

### Delete a caller ID record

- Follow the steps in **Review caller ID** (page 27) to find the record to be deleted.
- Press **REMOVE** on the handset (or **DELETE** on the base) to delete the record. A confirmation beep will sound and the previous CID record will be displayed.

### Delete all caller ID entries

- To delete all caller ID records when you are reviewing the call log, press and hold **REMOVE** on the handset (or **DELETE** on the base). The screen will display **DELETE ALL CALLS?** Press **SEL** to confirm. Press **OFF** on the handset (or **CLEAR** on the base) to return to the call log record previously displayed.

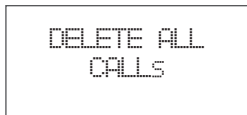

DELETE ALL  
CALLS

## note

- The handset will not ring when a call comes in if ringer volume is at the lowest setting.
- Settings for the handset and the base must be programmed separately. For example, when you set the ringer volume for the handset, it will not automatically set in the base.
- Key tone is preset to **ON**.

## Telephone settings

### Ringer volume

- With the handset or base in idle (off) mode, press **MENU** then press **▲** or **▼** until **RINGER VOLUME** is shown.
- Press **SEL**. You will hear a sample of the ringer.
- Press **▲**, **▼** or a digit (0 through 6). You will hear a sample of the new ringer volume and the volume bar will be increased or decreased each time the setting is adjusted. At the lowest setting the ringer will be turned off and the display will show:

#### - OR -

- With the handset or base in idle (off) mode, press **▲** or **▼** of the volume control will directly go to ringer volume menu.
- Press **▲** or **▼** to adjust the ringer volume.

### Ringer tone

- With the handset or base in idle (off) mode, press **MENU** then press **▲** or **▼** until **RINGER TONE** is displayed.
- Press **SEL**. Then press **▲**, **▼** or a digit (0 through 9). You will hear a sample of the ring tone and you will see the number of that ring tone, (0 - 9).
- Press **SEL** to confirm.

### Key tone

- With the handset or base in idle (off) mode, press **MENU** then press **▲** or **▼** to until **KEY TONE** is displayed.
- Press **SEL**. The current setting will be shown. Press **▲** or **▼** to see **ON** or **OFF**. When set to on, the handset or base will emit a beep whenever a key is pressed.
- When the desired option is shown, press **SEL**.

>RINGER VOLUME  
RINGER TONE

RINGER VOLUME



>RINGER TONE  
KEY TONE

KEY TONE  
OFF

## Telephone settings

### Language

- From the idle (off) mode, press **MENU** then press **▲** or **▼** until **LANGUAGE** is displayed.
- Press **SEL**. Press **▲** or **▼** to choose between **ENGLISH**, **FRENCH** or **SPANISH**.
- Press **SEL** to confirm. (The language is preset to English.)

```
LANGUAGE
ENGLISH
```

### Clear voicemail

- From the idle (off) mode, press **MENU** then press **▲** or **▼** until **CLR VOICE MAIL** is displayed.
- Press **SEL**.
- Press **SEL** again to confirm or press **OFF** to exit.

```
>CLR VOICE MAIL
DIAL TYPE
```

```
TURN INDICATOR
OFF?
```

### Dial type

- From idle (off) mode, press **MENU** then **▲** or **▼** to **DIAL TYPE**.
- Press **SEL** then **▲** or **▼** to scroll to **TONE** (touch tones) or **PULSE** (rotary).
- Press **SEL** to confirm. The dial type is preset to **TONE**.

```
>DIAL TYPE
DIRECTORY
```

```
DIAL TYPE
PULSE
```

### note

- This function only cancels the indication of voicemail on the handset and base displays. It does not cancel the actual voicemail status at the telephone company.
- When the phone is set to pulse, it is possible to switch to temporary tone during a call by pressing **\*TONE**. Once pressed, tone will be used for rest of the call. After hanging up, the phone will return to pulse for the next call.



## note

- When your answering system is powered off, you can still play your messages and change the answering system settings

## Answering system operation

Your answering system has approximately 15 minutes of recording time, and it can record up to 99 messages. Each message is limited to four minutes.

### Turn the answering feature on and off



Press the **ANS ON/OFF** button on the telephone base to turn the answering system on or off. When the feature is on, the **ANS ON/OFF** button will be lit, the system will answer calls, and incoming messages can be recorded.

### Day and time announcements

#### To set day and time



Before playing each recorded message, the answering system announces the day and time the message was received.

Set the day and time by pressing **TIME/SET** twice. You can change settings by pressing **CHANGE**, and you can advance to the next type of setting by pressing **TIME/SET** again. See the following page for more detailed instructions.

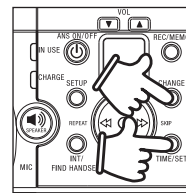
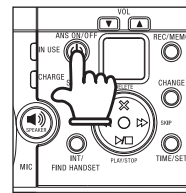

## Answering system operation

Before using the answering system, you should follow the steps to set the day and time, so messages are dated correctly. Each time you press and release the **CHANGE** button on the telephone base, the day, hour, minute, or year advances by one unit. When you hear the correct setting, press **TIME/SET** to move to the next setting. Pressing and holding the **CHANGE** button when setting the day and time will increase the minutes or years by 10.

1. Press **TIME/SET**, the system announces the current setting.
2. Press **TIME/SET** again.
3. The answering system will announce the current day setting. Press **CHANGE** on the base until you hear the correct day.
4. Press **TIME/SET**, the system announces the current hour setting.
5. Press **CHANGE** until you hear the correct hour.
6. Press **TIME/SET**, the system announces current minute setting.
7. Press **CHANGE** until you hear the correct minute.
8. Press **TIME/SET**, the system announces the current year setting.
9. Press **CHANGE** until you hear the correct year.
10. Press **TIME/SET** to confirm. The system announces the new time and day setting followed by a confirmation beep.

### To check day and time

Press **TIME/SET** at any time and the system will announce the current setting without changing it.

#### note

- If you have caller ID service, the time will automatically be updated whenever caller ID information is delivered. However, since the date, rather than the day, is delivered, you have to program the year once, so the system can derive the day of the week.
- Pressing and holding the **CHANGE** button when setting the time and date will advance the minutes or years by 10.

## note

- Caller ID provides the time and date. Set the year so that the day of the week can be set from the caller ID information. After setting the time once, it will thereafter be set automatically with incoming caller ID information. The time will be set automatically only if the caller ID service is subscribed from your local telephone company.
- Announcements less than three seconds will not be recorded.

## Answering system operation

### Menu features

System announces	Description
"Announcements"	Change the code, (set to 19 at the factory,) required to listen to messages from a remote touch-tone phone.
"Remote access code"	Set code to access remotely from a touch tone phone.
"Message alert"	Beeps every 10 seconds when there are new messages.
"Announcement only"	Outgoing message only. No recording of incoming messages.
"Call screening"	Turn call screening on or off.
"Number of rings"	Change the number of times the system rings before it answers a call, (2, 4, 6 or toll saver).

### Outgoing announcement

Your answering system is pre-programmed with an announcement for normal (answer and record) mode. If the phone is set up to record messages, the phone answers calls with *"Hello. Please leave a message after the tone."* You can use this announcement, or replace it with a recording of your own.

### Record outgoing announcement

1. Press **SETUP**, the system announces *"Announcement. Press PLAY or press RECORD. To continue set up, press SETUP."*
2. Press **REC/MEMO**. After you hear *"Record after the tone. Press STOP when you are done,"* speak toward the **MIC** to record an announcement for up to 90 seconds.
3. The elapsed time (in seconds) is shown in the message window when recording.

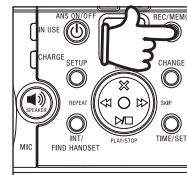

## Answering system operation

4. Press **PLAY/STOP** ►/■ when you have finished recording. The system will play back your recorded message and then save it.

### Listen to outgoing announcement

1. Press **SETUP**.
2. Press **PLAY/STOP** ►/■.



### Delete outgoing announcement

1. Press **SETUP**.
2. Press **PLAY/STOP** ►/■ to begin playback.
3. During playback, press **DELETE X** to delete the announcement.
4. The system will confirm deletion with the prompt *“Announcement deleted.”*



When the announcement is deleted, calls will be answered with the programmed announcement *“Hello. Please leave a message after the tone.”*

### Message playback



Press **PLAY/STOP** ►/■ to listen to new messages. The system will announce the number of new messages recorded and then start playing them starting with the oldest one. If there are no new messages, all old messages will be played from the beginning until the voice prompt *“End of messages.”*

## note

- The number of messages in the oval message window flashes when there are new messages. The number in the message window is on steady when are no new messages.
- While the telephone base is idle (off), press the **VOL ▲** and **▼** buttons to change the telephone base ringer volume. While listening to an incoming message or message playback press the **VOL ▲** and **▼** buttons to change the listening volume.

## Answering system operation

### Announcements

1. When playback begins, the total number of messages will be announced.
2. Before each message, the day and time it was received will be announced.
3. After the last message the system will announce, “*End of messages.*”
4. If the system has less than five minutes of recording time left, the time remaining will also be announced.

### Options during playback

1. Press **▼** and **▲** to adjust the speaker volume.
2. Press **SKIP ►** once to skip to the next message, or press and hold to speed up the message playback, using the voice prompt of day and time as index.
3. Press **REPEAT ◀** to repeat the message currently playing. Press twice to listen to the previous message, or press and hold to slow down the message playback process.
4. Press **DELETE X** to delete the message currently playing.
5. Press **PLAY/STOP ►/■** to stop playback.

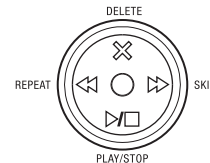

### Delete all messages

To delete all messages, press and hold **DELETE X** while the phone is idle (not during a call or during message playback) to delete all old messages. New messages (which haven't been heard before) will not be deleted.

## Answering system operation

### Record and play memos

Memos are messages recorded by you or other household members intended for yourself or anyone else who uses the answering system. They are saved, played back, and deleted like incoming messages from other callers.

#### Record a memo

1. Press **REC/MEMO**.
2. You will hear the voice prompt *"Record after the tone. Press **STOP** when you are done."*
3. Speak toward the **MIC** to record a memo for up to 90 seconds.
4. The timer shows the elapsed time (in seconds) in the message window when you are recording.
5. When finished recording, press **PLAY/STOP** ►/■ to save the memo.  
The system announces *"Recorded"* to confirm.

#### Play back a memo

See Section on **Message playback** about retrieving memos.

### Remote access code

To retrieve new messages from any touch tone phone from a remote location, a two digit access code is required. The remote access code can be any two digit number between 10 and 99. The remote access code has been set to 19 at the factory but it can be changed it to any two digit number any time for your convenience.

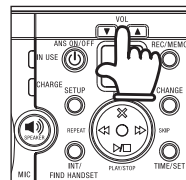
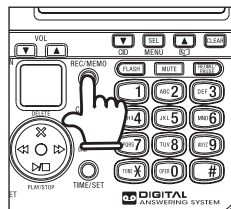

## note

- Memos less than three seconds will not be recorded. You can record a memo up to four minutes long.

## Answering system operation

### Set remote access code

1. Press **SETUP** twice, the system will announce *"Remote access code. To change the setting, press CHANGE."*
2. Because the remote access code was set to 19 at the factory, press **CHANGE**, the system announces *"19."*
3. Press and release **CHANGE** to advance the remote access code number by one. Press and hold **CHANGE** to advance the remote access code by 10.
4. When the desired number is heard. Press **SETUP** to save and advance to the next menu option or press **PLAY/STOP** ►/■ to save and exit.

### Remote operation

1. From any touch tone telephone, dial your telephone number.
2. While your outgoing announcement is playing, enter the two digit remote access code before taking the following actions.
3. Hang up to end the call and save all undeleted messages.

If you pause for more than 10 seconds during remote access, you will hear a help menu listing all features and commands. If no command is entered for the following 20 seconds, the call will end automatically.

## Answering system operation

Purpose	Press	Action
Play all messages in the mailbox	<b>1</b>	Listen to new messages. If there are no new messages, all messages will be played back.
Play new messages in the mailbox	<b>2</b>	Plays all new (not previously listened to) messages.
Delete a message	<b>3</b>	Delete message currently playing.
Delete all old messages	<b>3,3</b>	Press when any message is playing to delete all old (previously reviewed) messages.
Repeat a message	<b>4</b>	Press to repeat current message.
Repeat the previous message	<b>4,4</b>	Press to repeat previous message.
Stop	<b>5,</b>	Press to stop messages from being played.
Skip a message	<b>6</b>	Press to skip to the next message.
Review announcement	<b>#7</b>	Listen to current outgoing announcement.



## note

- Your phone may not respond to remote access commands if tones produced by the telephone from which you are calling are too short. Hold the buttons down longer if this occurs.
- If accessing from a touch tone telephone, press **#5** to stop recording.

## Answering system operation

Purpose	Press	Action
Record announcement	*7	Press after hearing the beep. Record your new announcement. Press <b>5</b> to stop recording. The system will play back the announcement for confirmation.
Record memo	8	Press after hearing the beep. Speak after the system announces <i>"Record after the tone. Press <b>STOP</b> when you are done."</i> Start recording your memo. Press <b>5</b> to stop.
Review remote access code	#9	Listen to current remote access code.
Change remote access code	*7	Change remote access code.
Turn system off	0	When the system announces, <i>"Answering machine off,"</i> press <b>0</b> again to turn the system back on.
Turn system on	0	When the system is off, it answers after 10 rings and announces, <i>"Please enter your remote access code."</i> Enter your remote access code.

### Message alert

The message alert function produces an audio tone to remind you that there are new messages on the answering system.

1. Press **SETUP** three times and you will hear *"Message alert. To change the setting, press **CHANGE**."*
2. Press **CHANGE** to confirm the current status; on or off is also displayed on the message window.
3. Press **CHANGE** again to change the setting.
4. Press **SETUP** to save and advance to the next menu option or press **PLAY/STOP** ►/■ to save and exit.

## Answering system operation

When the message alert function is turned on, the telephone base beeps every 10 seconds, and **PLAY/STOP** ►/■ and the number of messages in the oval message window flash when there are new messages.

If **PLAY/STOP** ►/■ and the number in the message window are on steadily, there are no new messages.

### Announcement only mode

In announcement only mode, callers hear an announcement but cannot leave messages. When announcement only is turned on, calls are answered with the pre-recorded announcement “*We’re sorry. Messages to this number cannot be accepted*” or you may record your own message.

### Turn announcement only mode on or off

- Press **SETUP** four times, the system will announce “*Announcement only. Record no messages. To change the setting, press CHANGE.*”
- Press **CHANGE** until you hear the option you want (on or off).
- Press **PLAY/STOP** ►/■ to save your selection and exit.

### Record the announcement only message

1. Press **SETUP** four times, the system will announce “*Announcement only. Record no messages. To change the setting, press CHANGE.*”
2. Press **CHANGE** until you hear the option on.
3. Press **SETUP** three times, the system will announce “*Announcement. Press PLAY or press RECORD. To continue, press SETUP.*”
4. Press **REC/MEMO**. The system will announce, “*Record after the tone. Press STOP when you are done.*” Speak toward the **MIC** to record an announcement for up to 90 seconds.
5. The elapsed time (in seconds) will be shown in the message window while you are recording.
6. Press **PLAY/STOP** ►/■ when you have finished recording. The system will play back your recorded message before saving it.

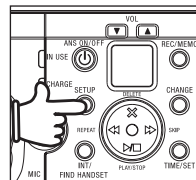

## note

- While the telephone base in idle (off) mode, press the **VOL** buttons to change the telephone base ringer volume. While listening to an incoming message or message playback press the **VOL** buttons to change the listening volume.

## Answering system operation

### Call screening

If you wish to review caller ID or listen to caller's leaving their message before choosing to answer a call, follow these steps:

1. Set the playback **VOL** on the telephone base to a level greater than one on the message window by pressing ▲ or ▼ to adjust the volume for message playback.
2. If you decide to answer a call while the caller is leaving a message, simply press **TALK** or **SPEAKER** on the handset or base. The answering system will stop.

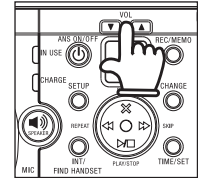

### Number of rings

This function sets the number of rings before the answering system picks up the call. When you call from a touch tone phone, if you have toll saver on, the answering system alerts you that you have new messages by answering after two rings. If there are no new messages, the system answers after four rings. When retrieving messages from a location where long distance charges apply, you may disconnect your call after three rings to avoid long distance charges.

1. Press **SETUP** six times, the system will announce "Number of rings. To change the setting, press **CHANGE**."
2. Press **CHANGE** to confirm the current status, which is also displayed on the oval message window.
3. Press **CHANGE** to set the number of rings to 2, 4, 6, or toll saver.
4. Press **SETUP** to save and advance to the next setup option, or press **PLAY/STOP** ►/■ to save and exit.

## Answering system operation

### Message window displays

Display	Explanation
0	No messages.
1 - 98	Total number of messages and memos, or message number currently playing. Number flashes if there are new messages.
1 - 8	Playback or ringer volume level selected when <b>VOL ▲</b> or <b>▼</b> is pressed.
10 - 99	Current remote access code while setting
1 - 99 (counting)	Elapsed time while recording a memo or announcement up to 90 seconds.
99 (flashing)	Memo or announcement recording exceeds maximum time of 99 seconds.
F (flashing)	Memory is full. Messages must be deleted before new messages can be recorded.
CL (flashing)	Clock needs to be set.
A	Announcement only mode is on.
--	Answering system is answering a call or being accessed from a remote location or the base speaker is being used.
-- (flashing)	System is in programming mode.
On or OFF	Displayed for one second when any answering system setting is turned on or off.
02, 04, 06, tS	Change number of rings until the system answers the call.

## note

- To purchase a headset, visit us on the web at [www.vtechphones.com](http://www.vtechphones.com) or call VTech Customer Service at 1-800-595-9511. In Canada, contact Telecommunications Canada Ltd. at [www.vtechcanada.com](http://www.vtechcanada.com) or 1-800-267-7377.

## Headset operation

### Headset jack

You can use this telephone handsfree when you install any VTech 2.5 mm headset, purchased separately.

Plug the headset into the jack located on the left side of the handset (under the small rubber flap). Do not force the connection, but ensure the plug fits securely.

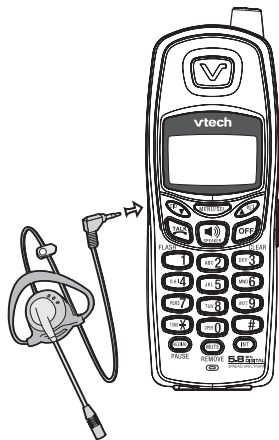

### Operating range

This cordless telephone operates within the maximum power allowed by the Federal Communications Commission (FCC). Even so, this handset and telephone base can communicate only over a certain distance - which can vary with the locations of the telephone base and handset, the weather, and the construction of your home or office.

If there is a call while the handset out of range, the handset might not ring or if it does ring, the call might not connect well when you press **TALK**. Move closer to the telephone base, then press **TALK** to answer the call.

If the handset is moved out of range during a phone conversation, you might hear noise or interference. To improve reception, move closer to the telephone base.

If you move out of range without pressing **OFF**, the phone will be left off the hook. To hang up properly, walk back into range, periodically pressing **OFF**.

## Batteries

### Battery care and performance

After the battery is fully charged, you can expect the following performance:

Operation	Operating time
While in use (talking)	up to 7.5 hours
While not in use (standby*)	up to 3.5 days

\* Handset is off the telephone base or charger but not in use.

- The battery needs charging when:
  - A new battery is installed in the handset.
  - The phone beeps twice every five seconds.
  - The screen displays **LOW BATTERY** and the low battery icon.
- Place the handset in the telephone base so the **CHARGE** light turns on. The battery is usually fully charged in about 16 hours.
- You can keep the battery fully charged by returning the handset to the telephone base after each use.

### Replace the handset battery

1. Remove the battery compartment cover on the handset by pressing on the indentation and sliding the cover downward.
2. Lift out the old battery and disconnect.
3. Align the two holes in the new battery's plug with the socket pins, and snap the plug into place. Snap the battery in the compartment, as described in **Installation**, on page 7.
4. Replace the cover by sliding it up into place.
5. The new battery must be fully charged before installing it into the phone. Place the handset in the telephone base and allow it to charge for at least 16 hours the first charge. The telephone might operate before that, but for best performance, let the battery charge fully.

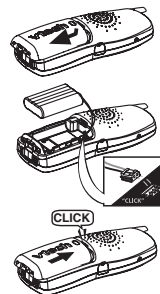

### note

- If you repeatedly get a low battery indicator, even after charging overnight, the battery should be replaced.
- To reduce the risk of fire or injury to persons or damage to the telephone, charge the battery provided with this product only in accordance with the instructions and limitations specified in the user's manual.

## Troubleshooting

If you have difficulty operating your phone, the suggestions below should solve the problem. If you still have difficulty after trying these suggestions, call VTech Communications at 1-800-595-9511. In Canada, call VTech Telecommunications Canada Ltd. at 1-800-267-7377.

Problem	Suggestion
My phone doesn't work at all.	<ul style="list-style-type: none"><li>• Make sure the power cord is plugged in.</li><li>• Make sure the telephone line cord is plugged firmly into the telephone base and the telephone wall jack.</li><li>• Disconnect the AC adaptor for a few minutes, and then reconnect it.</li><li>• Charge the battery in the handset for 16 hours. For optimum daily performance, return the handset to its telephone base when not in use.</li><li>• Reset the telephone base. Unplug the unit's electrical power. Wait for 15 seconds then plug it back in. Allow up to one minute for the handset and telephone base to reset.</li><li>• You may need to purchase a new battery, please refer to the <b>Batteries</b> section of this user's manual.</li></ul>
I cannot get a dial tone.	<ul style="list-style-type: none"><li>• Try all the suggestions above.</li><li>• Move the handset closer to the telephone base. You might have moved out of range.</li><li>• Your line cord might be malfunctioning. Try installing a new line cord.</li><li>• If the previous suggestions don't work, disconnect the telephone base from the telephone jack and connect a different phone. If there is no dial tone on that phone either, the problem is in your wiring or local service. Contact your local telephone company.</li></ul>

## Troubleshooting

Problem	Suggestion
I cannot dial out.	<ul style="list-style-type: none"><li>• Make sure you have a dial tone before dialing. The handset may take a second or two to find the telephone base and produce a dial tone. This is normal. Wait an extra second before dialing.</li><li>• Make sure your phone is set to the correct dial mode for the type of service that you have (pulse or touchtone). Refer to the <b>Telephone settings</b> section of this user's manual to set the dial mode.</li><li>• If the other phones in your home are having the issue, the problem is in your wiring or local service. Contact your local telephone company.</li><li>• Eliminate any background noise. Noise from a television, radio or other appliance may cause the phone not to dial out properly. If you cannot eliminate the background noise, first try muting the handset before dialing, or dialing from another room in your home with less background noise.</li></ul>



## Troubleshooting

Problem	Suggestion
<b>UNABLE TO CALL TRY AGAIN</b> displays on my handset.	<ul style="list-style-type: none"><li>• Move the handset closer to the telephone base. You might have moved out of range.</li><li>• If the handset is in its telephone base and the charging light does not light, refer to the charge light is off in this troubleshooting guide.</li><li>• Reset the telephone base. Unplug the unit's electrical power. Wait for 15 seconds then plug it back in. Allow up to one minute for the handset and telephone base to reset.</li><li>• Other electronic products can cause interference with your cordless phone. Try installing your phone as far away from these types of electronic devices as possible: wireless routers, radios, radio towers, pager towers, cell phones, intercoms, room monitors, televisions, personal computers, kitchen appliances and other cordless phones.</li></ul>
The battery does not hold a charge.	<ul style="list-style-type: none"><li>• Charge the battery in the handset for 16 hours. For optimum daily performance, return the handset to its telephone base when not in use.</li><li>• You may need to purchase a new battery, please refer to the <b>Batteries</b> section of this user's manual.</li><li>• Your phone might be malfunctioning. Please refer to the <b>Warranty</b> section of this user's manual for further instruction.</li></ul>
If you subscribe to DSL service	If you hear noise during conversations and/or your caller ID features aren't functioning properly, install a noise filter to the telephone line between the telephone base and the telephone line jack. Contact your DSL provider to obtain a noise filter.

## Troubleshooting

Problem	Suggestion
I get noise, static, or weak signal even when I'm near the telephone base.	<ul style="list-style-type: none"><li>• Other cordless phones and 802.11 wireless routers that are used for home computer networks both use internal radios to communicate. The radios may interfere with one another. You can improve the performance of your cordless phones and your router by:<ol style="list-style-type: none"><li>a. positioning your new phone as far away as possible from any other existing cordless telephone system that is already installed in your home to avoid the two systems interfering with each other.</li><li>b. positioning your telephone base as far as possible from your router, computer or any other computer devices.</li><li>c. selecting channels four through 10 for your router (refer to your router's user manual for more information).</li></ol></li><li>• Other electronic products can cause interference with your cordless phone. Try installing your phone as far away from these types of electronic devices as possible: wireless routers, radios, radio towers, pager towers, cell phones, intercoms, room monitors, televisions, personal computers, kitchen appliances and other cordless phones.</li><li>• Microwaves operate on the same frequency as your phone. It is normal to experience static on your phone while the microwave is running. Do not install this phone in the same outlet or near the microwave.</li><li>• If your phone is plugged in with a modem or surge protector, plug the phone (or modem/surge protector) into a different location. If this solves the problem, re-locate your phone or modem farther apart from one another, or use a different surge protector.</li><li>• Relocate your phone to a higher location. The phone will likely get better reception not installed in a low area.</li><li>• If the other phones in your home are having the issue, the problem is in your wiring or local service. Contact your local telephone company (charges may apply.)</li></ul>
I hear other calls while using my phone.	<ul style="list-style-type: none"><li>• Disconnect your telephone base from the telephone jack, and plug in a regular telephone. If you still hear other calls, the problem is probably in your wiring or local service. Call your local telephone company.</li></ul>

# Troubleshooting

Problem	Suggestion
<p>My handset does not ring when I receive a call.</p>	<ul style="list-style-type: none"><li>• Make sure you have the ringer activated. Refer to the section(s) on ringer selection in this user's manual.</li><li>• Make sure the telephone line cord is plugged firmly into the telephone base and the telephone jack. Make sure the power cord is plugged in.</li><li>• You may be too far from the telephone base.</li><li>• Charge the battery in the handset for 16 hours. For optimum daily performance, return the handset to its telephone base when not in use.</li><li>• You may have too many extension phones on your telephone line to allow all of them to ring. Try unplugging some of the other phones.</li><li>• The layout of your home or office might be limiting the operating range. Try moving the telephone base to another location, preferably on an upper floor.</li><li>• If the other phones in your home are having the issue, the problem is in your wiring or local service. Contact your local telephone company (charges may apply).</li><li>• Test a working phone at the phone jack. If another phone has the same problem, the problem is the phone jack. Contact your local telephone company (charges may apply).</li><li>• Other electronic products can cause interference with your cordless phone. Try installing your phone as far away from these types of electronic devices as possible: wireless routers, radios, radio towers, pager towers, cell phones, intercoms, room monitors, televisions, personal computers, kitchen appliances and other cordless phones.</li><li>• Your line cord might be malfunctioning. Try installing a new line cord.</li></ul>

## Troubleshooting

Problem	Suggestion
My calls fade or cut in and out while I'm using my handset.	<ul style="list-style-type: none"><li>• Other electronic products can cause interference with your cordless phone. Try installing your phone as far away from these types of electronic devices as possible: wireless routers, radios, radio towers, pager towers, cell phones, intercoms, room monitors, televisions, personal computers, kitchen appliances and other cordless phones</li><li>• Microwaves operate on the same frequency as your phone. It is normal to experience static on your phone while the microwave is running. Do not install this phone in the same outlet or near the microwave.</li><li>• If your phone is plugged in with a modem or surge protector, plug the phone (or modem/surge protector) into a different location. If this solves the problem, re-locate your phone or modem farther apart from one another, or use a different surge protector.</li><li>• Relocate your phone to a higher location. The phone will get better reception not installed in a low area.</li><li>• If the other phones in your home are having the issue, the problem is in your wiring or local service.</li></ul>
The charge light is off.	<ul style="list-style-type: none"><li>• Clean the handset and telephone base charging contact each month using a pencil eraser or cloth.</li><li>• Make sure the power and line cords are plugged in correctly and firmly.</li><li>• Reset the telephone base. Unplug the unit's electrical power. Wait for 15 seconds then plug it back in. Allow up to one minute for the handset and telephone base to reset.</li><li>• Your phone might be malfunctioning. Please refer to the <b>Warranty</b> section of this user's manual for further instruction.</li></ul>

# Troubleshooting

Problem	Suggestion
My Caller ID isn't working.	<ul style="list-style-type: none"><li>• Caller ID is a subscription service. You must subscribe to this service for this feature to work on your phone.</li><li>• Your caller must be calling from an area that supports caller ID.</li><li>• Both you and your caller's telephone companies must use caller ID compatible equipment.</li></ul>
My answering machine is not recording messages.	<ul style="list-style-type: none"><li>• Make sure system is turned <b>ON</b> (the <b>ANS ON/OFF</b> key is illuminated).</li><li>• Make sure the announcement only feature is set to <b>OFF</b>.</li></ul>
I cannot hear recorded messages.	<ul style="list-style-type: none"><li>• Using the telephone base volume control, raise the volume to a comfortable listening level.</li></ul>
<b>CL</b> is flashing in the telephone base message display window.	<ul style="list-style-type: none"><li>• You need to set the day and time. Refer to the section(s) on setting day and time in this user's manual.</li><li>• Make sure announce only feature is set to <b>OFF</b>.</li></ul>
Common cure for electronic equipment.	<p>If the unit does not seem to be responding normally, then try putting the handset in its telephone base. If it does not seem to respond, do the following (in the order listed):</p> <ol style="list-style-type: none"><li>1. Disconnect the power to the telephone base.</li><li>2. Disconnect the handset battery, and spare battery, if applicable.</li><li>3. Wait a few minutes.</li><li>4. Connect power to the telephone base.</li><li>5. Re-install the battery(ies).</li><li>6. Wait for the handset to re-establish its link with the telephone base. To be safe, allow up to one minute for this to take place.</li></ol>

# Troubleshooting

Problem	Suggestion
<p>I lost a handset and just bought a new one. How do I register the new one ?</p>	<ul style="list-style-type: none"><li>• Press and hold <b>INT/FIND HANDSET</b> on the main telephone base for 10 seconds.</li><li>• When the <b>IN USE</b> light starts to flash, release the <b>INT/FIND HANDSET</b> button.</li><li>• Press and release <b>INT/FIND HANDSET</b> again. The <b>IN USE</b> light will turn off and in a few seconds, all handsets will be de-registered.</li><li>• All handsets will show <b>NOT REGISTERED</b>.</li><li>• Place the handset in its charger (connected to a power outlet.) If <b>PRESS FIND HNDST 4 SECS ON BASE</b> does not appear on the screen after a few seconds, lift up handset and place in the charger again.</li><li>• On the main telephone base,<ul style="list-style-type: none"><li>• Press and hold <b>INT/FIND HANDSET</b> key for four seconds.</li><li>• Release <b>INT/FIND HANDSET</b> key when <b>IN USE</b> light is on.</li></ul></li><li>• The LCD screen on the telephone base will show, <b>HS REGISTERED</b>.</li><li>• The handset will show <b>HS REGISTERED</b> and beep once.</li></ul> <p>After about 10 seconds the handset will emit a tone and the handset will be assigned the lowest extension number not previously assigned to another system handset (1-4) when successfully registered. Repeat steps 1 and 2 if handset is not registered within two minutes</p>

# Maintenance

## Taking care of your telephone

Your cordless telephone contains sophisticated electronic parts, so it must be treated with care.

Avoid rough treatment

Place the handset down gently. Save the original packing materials to protect your telephone if you ever need to ship it.

## Avoid water

Your telephone can be damaged if it gets wet. Do not use the handset outdoors in the rain, or handle it with wet hands. Do not install your telephone base near a sink, bathtub or shower.

## Electrical storms

Electrical storms can sometimes cause power surges harmful to electronic equipment. For your own safety, use caution when using electric appliances during storms.

## Cleaning your telephone

Your telephone has a durable plastic casing that should retain its luster for many years. Clean it only with a soft cloth slightly dampened with water or a mild soap. Do not use excess water or cleaning solvents of any kind.

Remember that electrical appliances can cause serious injury if used when you are wet or standing in water. If your telephone base should fall into water, DO NOT RETRIEVE IT UNTIL YOU UNPLUG THE POWER CORD AND TELEPHONE LINE CORDS FROM THE WALL. Then pull the unit out by the unplugged cords.

# Warranty

## What does this limited warranty cover?

- The manufacturer of this VTech product, VTech Communications, warrants to the holder of a valid proof of purchase ("Consumer" or "you") that the product and all accessories provided by VTech in the sales package ("Product") are free from material defects in material and workmanship, pursuant to the following terms and conditions, when installed and used normally and in accordance with operation instructions. This limited warranty extends only to the Consumer for Products purchased and used in the United States of America.

## What will VTech Communications do if the Product is not free from material defects in materials and workmanship during the limited warranty period ("Materially Defective Product")?

- During the limited warranty period, VTech's authorized service representative will repair or replace at VTech's option, without charge, a Materially Defective Product. If we repair this product, we may use new or refurbished replacement parts. If we choose to replace this product, we may replace it with a new or refurbished product of the same or similar design. VTech will return repaired or replacement products to you in working condition. VTech will retain defective parts, modules, or equipment. Repair or replacement of Product, at VTech's option, is your exclusive remedy. You should expect the repair or replacement to take approximately 30 days.

## How long is the limited warranty period?

- The limited warranty period for the product extends for ONE (1) YEAR from the date of purchase if we repair or replace a Materially Defective Product under the terms of this limited warranty. This limited warranty also applies to repaired or replacement Products for a period of either (a) 90 days from the date the repaired or replacement Product is shipped to you or (b) the time remaining on the original one-year warranty; whichever is longer.

## What is not covered by this limited warranty?

This limited warranty does not cover

1. Product that has been subjected to misuse, accident, shipping or other physical damage, improper installation, abnormal operation or handling, neglect, inundation, fire, water or other liquid intrusion; or
2. Product that has been damaged due to repair, alteration or modification by anyone other than an authorized service representative of VTech; or
3. Product to the extent that the problem experienced is caused by signal conditions, network reliability or cable or antenna systems; or

# Warranty

4. Product to the extent that the problem is caused by use with non-VTech electrical accessories; or
5. Product whose warranty/quality stickers, Product serial numbers plates or electronic serial numbers have been removed, altered or rendered illegible; or
6. Product purchased, used, serviced, or shipped for repair from outside the United States, or used for commercial or institutional purposes (including but not limited to Products used for rental purposes ); or
7. Product returned without valid proof of purchase (see 2 below); or
8. Charges for installation or set up, adjustment of customer controls, and installation or repair of systems outside the unit.

## How do you get warranty service?

- To obtain warranty service in the United States of America, call 1-800-595-9511 for instructions regarding where to return the Product. Before calling for service, please check the user's manual. A check of the Product controls and features may save you a service call.
- Except as provided by applicable law, you assume the risk of loss or damage during transit and transportation and are responsible for delivery or handling charges incurred in the transport of Product (s) to the service location. VTech will return repaired or replaced product under this limited warranty to you, transportation, delivery or handling charges prepaid. VTech assumes no risk for damage or loss of the Product in transit.
- If the Product failure is not covered by this limited warranty, or proof of purchase does not meet the terms of this limited warranty, VTech will notify you and will request that you authorize the cost of repair prior to any further repair activity. You must pay for the cost of repair and return shipping costs for the repair of Products that are not covered by this limited warranty.

## What must you return with the Product to get warranty service?

1. Return the entire original package and contents including the Product to the VTech service location along with a description of the malfunction or difficulty;
2. Include "valid proof of purchase" (sales receipt) identifying the Product purchased (Product model) and the date of purchase or receipt; and
3. Provide your name, complete and correct mailing address, and telephone number.

## Other Limitations

- This warranty is the complete and exclusive agreement between you and VTech. It supersedes all other written or oral communications related to this Product. VTech provides no other warranties for this product. The warranty exclusively describes all of VTech's responsibilities regarding the product. There are no other express warranties. No one is authorized to make modifications to this limited warranty and you should not rely on any such modification.

State Law Rights: This warranty gives you specific legal rights, and you may also have other rights which vary from state to state.

Limitations: Implied warranties, including those of fitness for a particular purpose and merchantability (an unwritten warranty that the product is fit for ordinary use) are limited to one year from date of purchase. Some states do not allow limitations on how long an implied warranty lasts, so the above limitation may not apply to you.

- In no event shall VTech be liable for any indirect, special, incidental, consequential, or similar damages (including, but not limited to lost profits or revenue, inability to use the product, or other associated equipment, the cost of substitute equipment, and claims by third parties) resulting from the use of this product. Some states do not allow the exclusion or limitation of incidental or consequential damages, so the above limitation or exclusion may not apply to you.



# Important safety instructions

When using your telephone equipment, basic safety precautions should always be followed to reduce the risk of fire, electric shock and injury, including the following:

1. Read and understand all instructions.
2. Follow all warnings and instructions marked on the product.
3. Unplug this product from the wall outlet before cleaning. Do not use liquid or aerosol cleaners. Use a damp cloth for cleaning.
4. Do not use this product near water (for example, near a bath tub, kitchen sink or swimming pool).
5. Do not place this product on an unstable surface, such as a table, shelf or stand. The product may fall, causing serious damage.
6. Slots and openings in the back or bottom of the telephone base and handset are provided for ventilation. To protect them from overheating, these openings must not be blocked by placing the product on a soft surface such as a bed, sofa or rug. This product should never be placed near or over a radiator or heat register. This product should not be placed in any area where proper ventilation is not provided.
7. This product should be operated only from the type of power source indicated on the marking label. If you are not sure of the type of power supply in your home, consult your dealer or local power company.
8. Do not allow anything to rest on the power cord. Do not install this product where the cord may have anyone walking on it.
9. Never push objects of any kind into this product through slots in the telephone base or handset as they may touch dangerous voltage points or short out parts that could result in a risk of fire or electric shock. Never spill liquid of any kind on the product.
10. To reduce the risk of electric shock, do not disassemble this product, but take it to an authorized service facility. Opening or removing parts of the telephone base or handset other than specified access doors may expose you to dangerous voltages or other risks. Incorrect reassembling can cause electric shock when the product is subsequently used.
11. Do not overload wall outlets and extension cords as this can result in the risk of fire or electric shock.
12. Unplug this product from the wall outlet and refer servicing to an authorized service facility under the following conditions:
  - A. When the power supply cord or plug is damaged or frayed.
  - B. If liquid has been spilled onto the product.
  - C. If the product has been exposed to rain or water.
  - D. If the product does not operate normally by following the operating instructions. Adjust only those controls that are covered by the operating instructions, as improper adjustment of other controls may result in damage and often requires extensive work by an authorized technician to restore the product to normal operation.
  - E. If the product has been dropped and the telephone base and/or handset has been damaged.
  - F. If the product exhibits a distinct change in performance.
13. Avoid using a telephone (other than cordless) during an electrical storm. There is a remote risk of electric shock from lightning.
14. Do not use the telephone to report a gas leak in the vicinity of the leak.
15. Only put the handset of your telephone next to your ear when it is in normal talk.

**SAVE THESE INSTRUCTIONS**

# FCC, ACTA and IC regulations

## FCC Part 15

This equipment has been tested and found to comply with the requirements for a Class B digital device under Part 15 of the Federal Communications Commission (FCC) rules. These requirements are intended to provide reasonable protection against harmful interference in a residential installation. This equipment generates, uses and can radiate radio frequency energy and, if not installed and used in accordance with the instructions, may cause harmful interference to radio communications. However, there is no guarantee that interference will not occur in a particular installation. If this equipment does cause harmful interference to radio or television reception, which can be determined by turning the equipment off and on, the user is encouraged to try to correct the interference by one or more of the following measures:

- \* Reorient or relocate the receiving antenna.
- \* Increase the separation between the equipment and receiver.
- \* Connect the equipment into an outlet on a circuit different from that to which the receiver is connected.
- \* Consult the dealer or an experienced radio/TV technician for help.

Changes or modifications to this equipment not expressly approved by the party responsible for compliance could void the user's authority to operate the equipment.

To ensure safety of users, the FCC has established criteria for the amount of radio frequency energy that can be safely absorbed by a user or bystander according to the intended usage of the product. This product has been tested and found to comply with the FCC criteria. The handset may be safely held against the ear of the user. The telephone base shall be installed and used such that parts of the user's body other than the hands are maintained at a distance of approximately 20 cm (8 inches) or more. If you choose to use a clipping device, please make sure to only use the supplied VTech belt clip.

## FCC Part 68 and ACTA

This equipment complies with Part 68 of the FCC rules and with technical requirements adopted by the Administrative Council for Terminal Attachments (ACTA). The label on the back or bottom of this equipment contains, among other things, a product identifier in the format US:AAEQ##TXXXX. This identifier must be provided to your local telephone company upon request.

The plug and jack used to connect this equipment to premises wiring and the telephone network must comply with applicable Part 68 rules and technical requirements adopted by ACTA. A compliant telephone cord and modular plug is provided with this product. It is designed to be connected to a compatible modular jack that is also compliant. An RJ11 jack should normally be used for connecting to a single line and an RJ14 jack for two lines. See Installation Instructions in the user's manual.

The Ringer Equivalence Number (REN) is used to determine how many devices you may connect to your telephone line and still have them ring when you are called. The REN for this product is encoded as the 6th and 7th characters following the US: in the product identifier (e.g., if ## is 03, the REN is 0.3). In most, but not all areas, the sum of all RENs should be five (5.0) or less. For more information, please contact your local telephone company.

This equipment may not be used with Party Lines. If you have specially wired alarm dialing equipment connected to your telephone line, ensure the connection of this equipment does not disable your alarm equipment. If you have questions about what will disable alarm equipment, consult your telephone company or a qualified installer.

If this equipment is malfunctioning, it must be unplugged from the modular jack until the problem has been corrected. Repairs to this telephone equipment can only be made by the manufacturer or its authorized agents. For repair procedures, follow the instructions outlined under the Limited Warranty.

If this equipment is causing harm to the telephone network, the telephone company may temporarily discontinue your telephone service. The telephone company is required to notify you before interrupting service. If advance notice is not practical, you will be notified as soon as possible. You will be given the opportunity to correct the problem and the telephone company is required to inform you of your right to file a complaint with the FCC. Your telephone company may make changes in its facilities, equipment, operation, or procedures that could affect the proper functioning of this product. The telephone company is required to notify you if such changes are planned.

If this product is equipped with a corded or cordless handset, it is hearing aid compatible.

If this product has memory dialing locations, you may choose to store emergency telephone numbers (e.g., police, fire, medical) in these locations. If you do store or test emergency numbers, please:

## FCC, ACTA and IC regulations

- Remain on the line and briefly explain the reason for the call before hanging up.
- Perform such activities in off-peak hours, such as early morning or late evening.

### Industry Canada

This equipment complies with regulations RSS210 and CS-03 of Industry Canada. Operation is subject to the following two conditions: (1) this device may not cause interference, and (2) this device must accept any interference, including interference that may cause undesired operation of the device.

The term "IC:" before the certification/registration number only signifies that the Industry Canada technical specifications were met.

The Ringer Equivalence Number (REN) for this terminal equipment is 0.1. The REN is an indication of the maximum number of devices allowed to be connected to a telephone interface. The termination on an interface may consist of any combination of devices subject only to the requirement that the sum of the RENs of all the devices does not exceed five.

## The RBRC® Seal



The RBRC® Seal on the nickel-metal-hydride battery indicates that VTech Communications, Inc. is voluntarily participating in an industry program to collect and recycle these batteries at the end of their useful lives, when taken out of service within the United States and Canada.

The RBRC® program provides a convenient alternative to placing used nickel-metal-hydride batteries into the trash or municipal waste, which may be illegal in your area.

VTech's participation in RBRC® makes it easy for you to drop off the spent battery at local retailers participating in the RBRC® program or at authorized VTech product service centers. Please call 1-800-8-BATTERY™ for information on Ni-MH battery recycling and disposal bans/restrictions in your area. VTech's involvement in this program is part of its commitment to protecting our environment and conserving natural resources.

**RBRC® is a registered trademark of Rechargeable Battery Recycling Corporation.**

## Technical specifications

Enhanced 5.8GHz technology—your **phone** operates on a dual band transmission that combines the best of 5.8GHz and 2.4GHz technologies, providing enhanced performance over standard cordless telephones.

<b>Frequency Control</b>	Crystal controlled PLL synthesizer
<b>Transmit Frequency</b>	Telephone base: 5725-5850 MHz Handset: 2400-2483.5 MHz
<b>Receive Frequency</b>	Telephone base: 2400-2483.5 MHz Handset: 5725-5850 MHz
<b>Channels</b>	95
<b>Nominal Effective Range</b>	Maximum power allowed by the FCC and IC. Actual operating range may vary according to environmental conditions at the time of use.
<b>Size</b>	Handset: 141mm X 49mm X 35mm Telephone base: 177mm X 120mm X 78mm Charger: 89mm X 78mm X 53mm
<b>Weight</b>	Handset: 141 grams Telephone base: 385 grams Charger: 76 grams
<b>Power Requirements</b>	Handset: 600mAh Ni-MH battery Telephone base: 9V DC @ 600mA Charger: 9V DC @ 200mA
<b>Memory</b>	Directory: 50 Memory locations, up to 32 digits, 16 characters per location CID: 50 memory locations

# Index

## A

- Additional information 47
- Adjusting handset volume 17
- Announcement only mode 41, 43
- Announcements 36
- Answering calls 17
- Answering system operation 32–43

## B

- Basic operation 15
- Batteries 45
- Battery care and performance 45
- Belt clip 9

## C

- Caller ID 26–29
- Caller ID - call waiting with CID 26
- Call forward 19
- Call screening 42
- Call transfer 20
- Characters by number 23
- Check battery indicator 8
- Check for dial tone 8
- Choose a location 6
- Clear voicemail 31
- Conference call 20
- Connect to phone line 7

## D

- Day and time announcements 32

60

- Delete a directory entry 25
- Delete all messages 36
- Delete outgoing announcement 35
- Dial from caller ID 29
- Dial type 31
- Directory 22–25

## E

- Edit a directory entry 24

## F

- FCC, ACTA and IC regulations 57–58
- Flash function 17

## G

- Getting started 4

## H

- Handset layout 13
- Headset jack 44
- Headset operation 44

## I

- If you subscribe to DSL service 9
- Important safety instructions 56
- Installation 6–9
- Install handset battery 6
- Intercom 18
- Intercom/find handset 20

## **K**

Key tone 30

## **L**

Language 31

Listen to outgoing announcement 35

## **M**

Maintenance 54

Making calls 17

Menu features 34

Message alert 40

Message playback 35

Message window displays 43

Mute 18

## **N**

Number of rings 42

## **O**

Options during playback 36

Outgoing announcement 34

## **P**

Parts checklist for mi6877 5

Parts checklist for mi6897 4

## **R**

Record outgoing announcement 34

Record the announcement only message 41

Redial 18

Registration 11–12

Remote access code 37

Remote operation 38

Replace the handset battery 45

Review and dial entries 24

Review caller ID 27

Ringer tone 30

Ringer volume 30

## **S**

Store a new entry 22

## **T**

Technical specifications 59

Telephone base layout 14

Telephone operation 17–21

Telephone settings 30–31

The RBRC® Seal 58

To check day and time 33

To de-register all handsets 12

Troubleshooting 46–53

Turn announcement only mode on or off 41

Turn the answering feature on and off 32

## **V**

Visual indicators 15–16

## **W**

Warranty 54–55

VTECH TELECOMMUNICATIONS LTD.

A member of THE VTECH GROUP OF COMPANIES.

Distributed in the U.S.A. by VTech Communications, Inc. Beaverton, Oregon

Distributed in Canada by VTech Telecommunications Canada Ltd., Richmond, B.C.

Copyright ©2006 for VTECH TELECOMMUNICATIONS LTD.

Printed in China.

91-000743-020-000

**vtech**<sup>®</sup>  
Innovation Beyond Technology™