

flextone[®]
GAME CALLS

HD E-GAME CALL

ECHO⁸⁰
*HIGH DEFINITION
E-GAME CALL*

User's Manual

Model # EX1

INCLUDED PARTS

- 1) ECHO™ 80 electronic game call - (1)
- 2) Padded Carrying Strap - (1)
- 3) Product Information Guide - (1)
- 4) Ground Peg - (1)

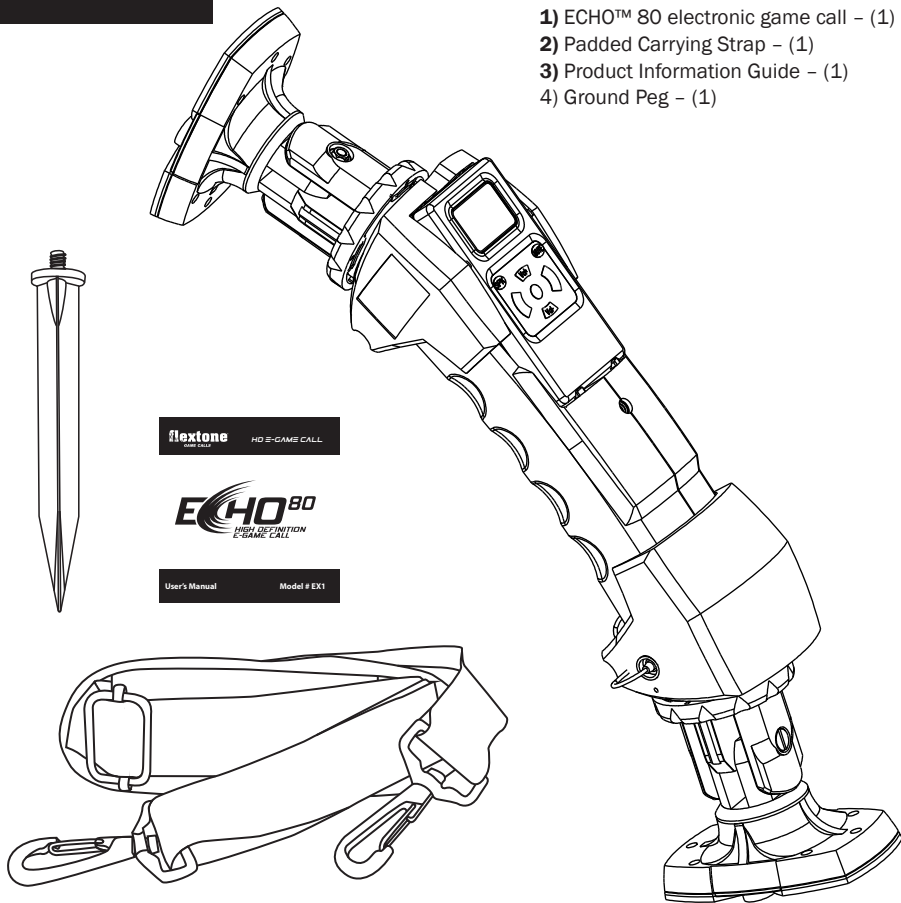

INSTALLING BATTERIES

1 Locate and remove the ECHO remote control by pulling the remote towards you and then sliding it up. (Illustration A)

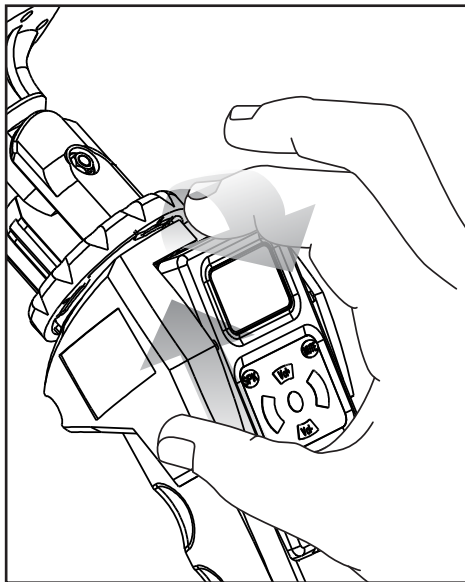

(Illustration A)

2 Remove the battery compartment cover by using a coin or a flat tip screw driver to unscrew the retaining screw. (Illustration B)

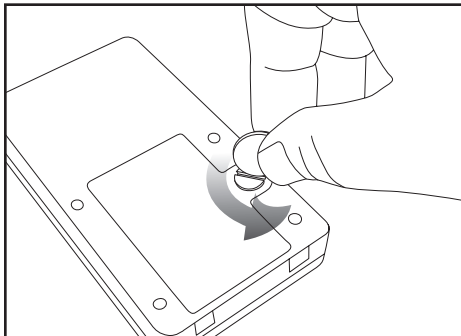

(Illustration B)

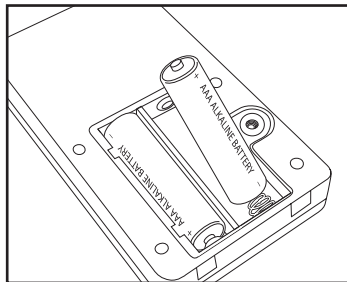

(Illustration C)

3 Install two AAA batteries (Not Included). '-' means that the '-' end of battery will be up when installed. '+' means '+' end of battery is up when installed. (Illustration C)

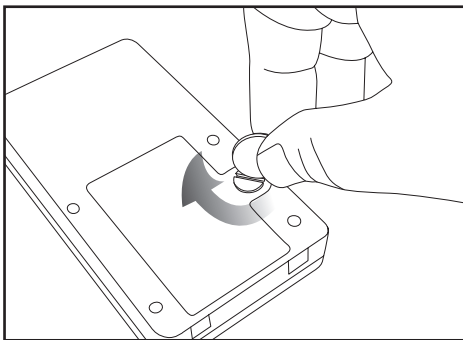

(Illustration D)

4 Reinstall and securely fasten the battery compartment retaining screw. (Illustration D)

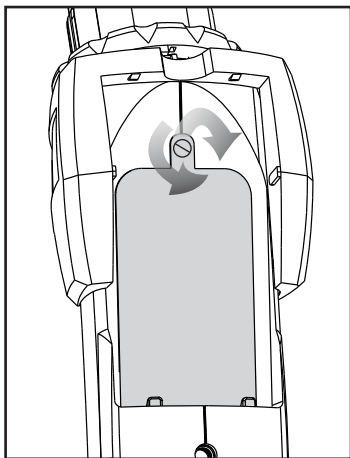

(Illustration E)

5 Next, locate the battery compartment flap on the Main unit. Remove the battery compartment flap by using a coin or a flat tip screw driver to unscrew the retaining screw. Once the screw is removed, pull the flap towards you. **NOTE:** the flap is not a separate piece from the unit and will not come off. (Illustration E)

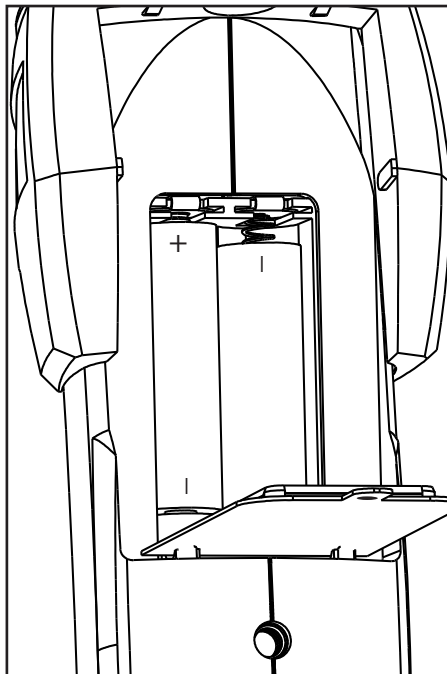

(Illustration F)

6 Install six AA batteries (Not Included).
'-' means that the '-' end of battery will be up when installed. '+' means '+' end of battery is up when installed. (Illustration F)

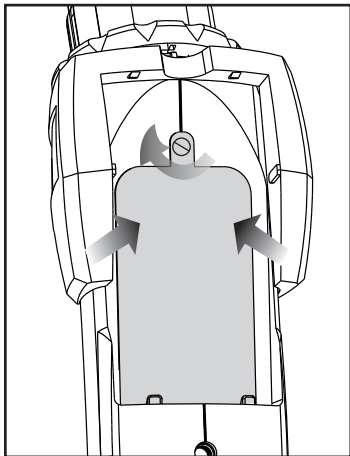

(Illustration G)

7 Securely fasten the battery flap by pushing the flap down and reinstall flat head screw. (Illustration G)

ATTACHING THE CARRYING STRAP

1 Attach carrying strap by locating the loops on each end of the main unit and connecting one end of the carrying strap to one of the loops. You can do the same when using bungee cords (Illustration H)

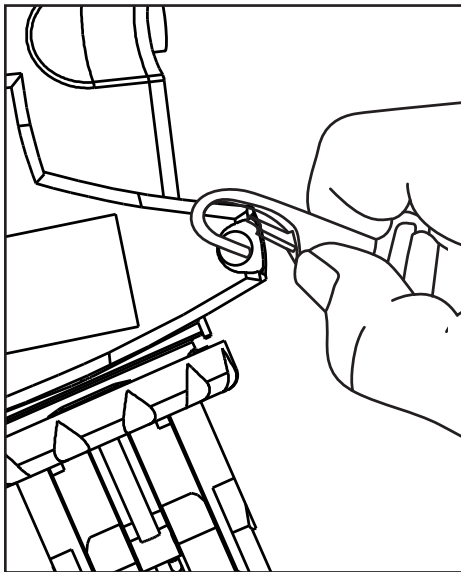

(Illustration H)

TO USE CALL

1 Turn the main unit on by pressing the power button located on the grip of the unit. This will activate the audible call. (Illustration I)

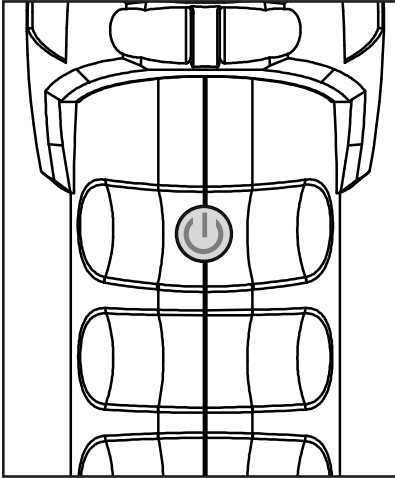

(Illustration I)

2 To maximize the effectiveness of the ECHO, decide how you would like to use it. It can either be held in the hand (Illustration J), mounted to a tree with bungee straps (not included) (Illustration H) or secure it in the ground with the ground peg (Illustration K).

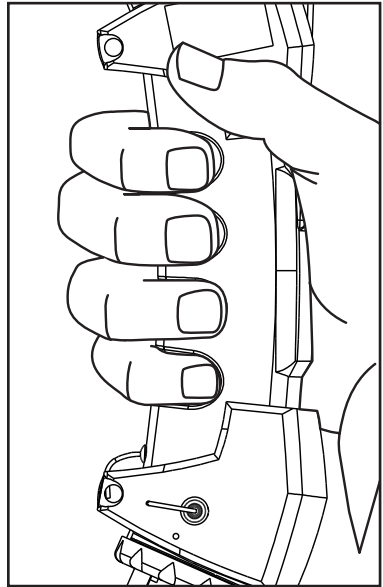

(Illustration J)

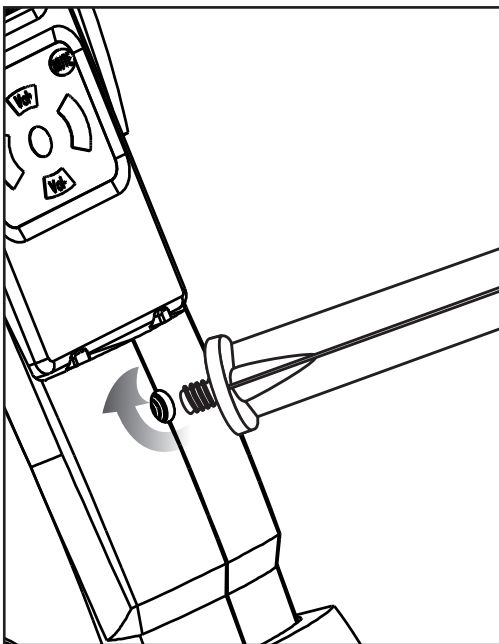

(Illustration K)

TURNING REMOTE ON

Press and hold the middle button until LCD is illuminated and then release. Unit is now on. **Note: The LCD will enter sleep mode in approximately 40 seconds.** (Illustration L)

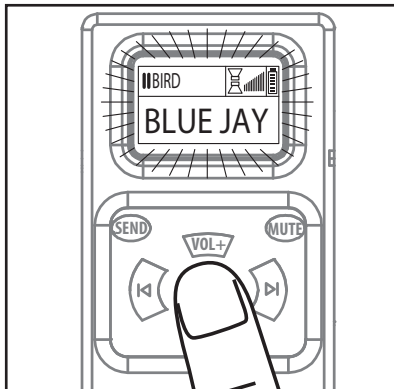

(Illustration L)

CHOOSING CALL CATEGORY

1 First, select desired call category by pressing and releasing the middle button. Category name should now be blinking. (Illustration M)

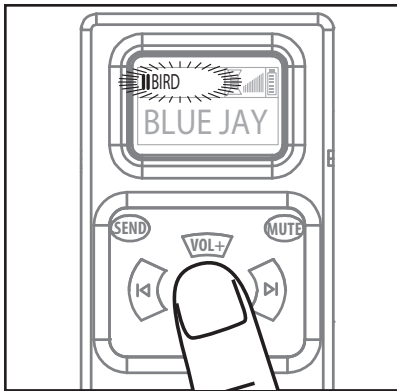

(Illustration M)

2 Next, press either the left or right button view the categories. (Illustration N)

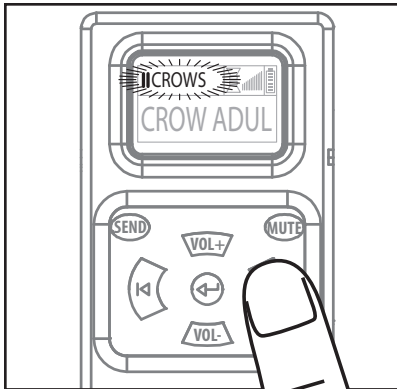

(Illustration N)

3 When desired category is identified, press and release middle button. (Illustration O)

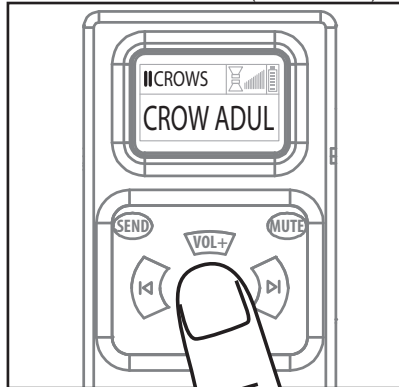

(Illustration O)

CHOOSING INDIVIDUAL CALLS

1 After the category has been chosen, scroll left or right to view individual calls within the category. (Illustration P)

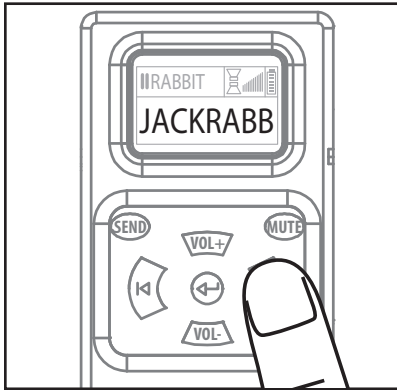

(Illustration P)

PLAYING THE SOUND SELECTED

Press the SEND button on the remote to send the selected sound to the main unit so it will play. Press MUTE on the remote to pause or play the current sound selected. (Illustration Q)

Note: Call will loop repeatedly until call is deactivated.

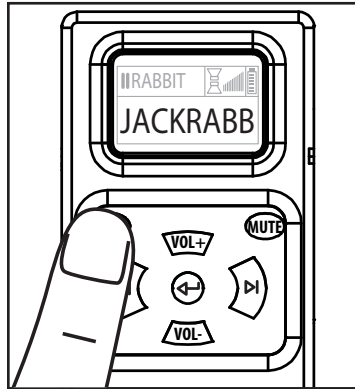

(Illustration Q)

VOLUME CONTROL

To adjust volume, press the volume up or down buttons. (Illustration R)

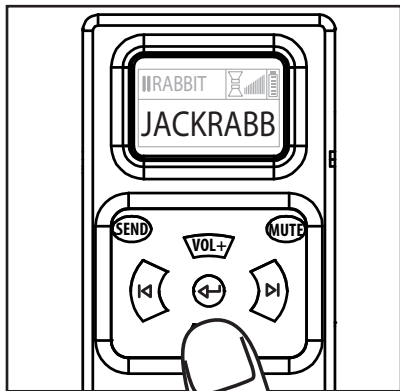

(Illustration R)

TURN UNIT OFF

To turn unit off, press and hold middle button until LCD display turns off. (Illustration S)

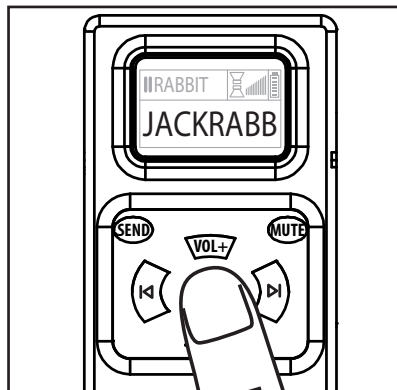

(Illustration S)

SPEAKERS

The speakers on the main unit can rotate 360° and tilt 180°. (Illustration T)

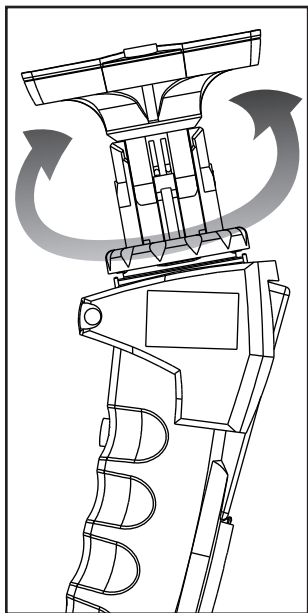

(Illustration T)

EXTERNAL PORT

There is an external speaker port (Illustration U).

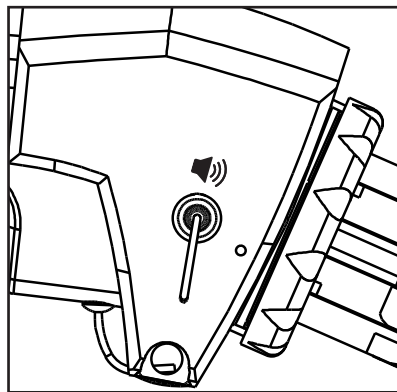

(Illustration U)

WARRANTY

DISCLAIMERS

WGI Innovations, LTD. is not responsible for damage, expense or injury caused by the unauthorized use of, alterations to, improper connection of and abuse or neglect of the WGI Innovations™ products.

WARRANTY

You must register your product warranty online at www.wildgameinnovations.com. Follow the on screen directions to complete the process. WGI Innovations, LTD. will replace any product that may encounter material or workmanship defects free of charge for ONE (1) YEAR after the date of purchase and thereafter the cost will vary per incident.

This warranty DOES NOT COVER damage, expense or injury caused by unauthorized repairs, alterations, improper connection, shipping, abuse, theft, accident, neglect or collateral loss.

When returning product for service you MUST obtain a Return Merchandise Authorization (RMA) number from WGI Innovations, LTD. Please include name, UPS address (no P.O. Box), telephone number, RMA number and a complete description of the problem on all enclosed correspondence. When possible, pack product carefully in original carton. Customers are responsible for any shipping cost to WGI Innovations™. WGI Innovations™ will

pay shipping cost of replacement product to the customer. We are not responsible for damage incurred in returning items for repair.

CUSTOMER SERVICE

WGI Innovations, LTD. stands behind every product we manufacture for a one year product workmanship warranty and a strong commitment to customer service. If you are in need of customer service for missing parts or need assistance with the operation or assembly of your product, we encourage you to call one of our customer service representatives and let us assist you with your WGI Innovations™ product.

DISCLAIMER

WGI Innovations, LTD. reserves the right to make changes to product features, functionality and physical design at its sole discretion. As a result, such changes may not be reflected in this version of the manual.

FCC STATEMENT

1. This device complies with Part 15 of the FCC Rules. Operation is subject to the following two conditions:

(1) This device may not cause harmful interference.

(2) This device must accept any interference received, including interference that may cause undesired operation.

2. Changes or modifications not expressly approved by the party responsible for compliance could void the user's authority to operate the equipment.

NOTE: This equipment has been tested and found to comply with the limits for a Class B digital device, pursuant to Part 15 of the FCC Rules. These limits are designed to provide reasonable protection against harmful interference in a residential installation.

This equipment generates uses and can radiate radio frequency energy and, if not installed and used in accordance with the instructions, may cause harmful interference to radio communications. However, there is no guarantee that interference will not occur in a particular installation. If this equipment does cause harmful interference to radio or television reception, which can be determined by turning the equipment off and on, the user is encouraged to try to correct the interference by one or more of the following measures:

- Reorient or relocate the receiving antenna.

- Increase the separation between the equipment and receiver.

- Connect the equipment into an outlet on a circuit different from that to which the receiver is connected.

- Consult the dealer or an experienced radio/TV technician for help.

WGI INNOVATIONS, LTD

602 Fountain Parkway
Grand Prairie, TX 75050
800.847.8269



"Flextone" is a registered trademark of Wild Game Innovations, LLC.
"ECHO" & "Sport Responsible" are TM trademarks of WGI Innovations, LTD.

