



# INSTALLATION & OPERATING INSTRUCTION MANUAL

## owners manual

### MODEL NOS.

4007332  
4007732  
5507332  
6257732

### FOR USE WITH NATURAL GAS ONLY



### MODEL NOS.

4007331  
4007731  
5507331  
6257731

### FOR USE WITH LIQUEFIED PETROLEUM (L.P.) GAS ONLY

Save This Manual For  
Future Reference.

# COUNTERFLOW DIRECT VENT GAS WALL FURNACES

## READ THIS OWNERS MANUAL CAREFULLY BEFORE YOU INSTALL YOUR NEW WILLIAMS WALL FURNACE



**WARNING:** If the information in this manual is not followed exactly, a fire or explosion may result causing property damage, personal injury or loss of life.

- Do not store or use gasoline or other flammable vapors and liquids in the vicinity of this or any other appliance.
- WHAT TO DO IF YOU SMELL GAS
  - Open all windows.
  - Do not try to light any appliance.
  - Do not touch any electrical switch; do not use any phone in your building.
  - Extinguish any open flame.
  - Immediately call your gas supplier from a neighbor's phone. Follow the gas supplier's instructions.
  - If you cannot reach your gas supplier, call the fire department.
- Installation and service must be performed by a qualified installer, service agency or the gas supplier.

**WARNING:** Improper installation, adjustment, alteration, service or maintenance can cause injury or property damage. Refer to this manual. For assistance or additional information consult a qualified installer, service agency or the gas supplier.

**WARNING:** This direct vent furnace is approved for aftermarket mobile home installations (once the mobile home is sold, installed and stationary) unless prohibited by local codes. Not for mobile home manufacturer (factory) installation. Do not install any of these furnaces (natural or L.P. Gas) in trailers or recreational vehicles.

**Williams Furnace Co., 225 Acacia St., Colton, CA 92324, USA**

# Contents

Your Williams Warranty	2	Vent Installation	12-13
Introduction	3	Mounting Your Furnace	14-15
Basic Description	3	Gas Supply and Piping	15-16
Optional Accessories	3	Electrical Wiring	17
Helpful Installation Information	3	Start Up Procedure	18
Safety Rules	4	Operating Your Furnace	19-24
Unpack Your Furnace	5	How To Care For Your Furnace	25-26
Basic Tools Needed	5	Furnace Technical Information	26
Basic Materials	5	Wiring Diagrams	27-28
Installing Your Wall Furnace	6	TRUBLESHOOTING CHART	29-34
Locating Wall Furnace and Thermostat	6-7	Repair Parts	35-44
Recessed Mount Installation	7-9	SERVICE HINTS	Back Cover
Surface Mount Installation	9-10	How To Order Repair Parts	Back Cover
Thermostat Installation	11-12		

---

## Your Warranty

The Manufacturer, Williams Furnace Co., warrants this wall furnace or heater to the original purchaser under the following conditions:

### LIMITED ONE-YEAR WARRANTY

1. Any part thereof which proves to be defective in material or workmanship within one year from date of original purchase for use will be repaired or replaced at the Manufacturer's option, FOB its factory.
2. No liability is assumed by the Manufacturer for removal or installation labor costs, nor for freight or delivery charges.

### LIMITED EXTENDED WARRANTY

1. In addition to the above limited one-year warranty on the complete unit, any heat exchanger which burns out or rusts under normal installation, use and service conditions during a period of nine years following expiration of the one-year warranty period will be exchanged for a like or functionally similar part, FOB Manufacturer's factory.
2. No liability is assumed by the Manufacturer for removal or installation labor costs, nor for freight or delivery charges.

### LIMITATIONS

1. THIS LIMITED WARRANTY IS THE ONLY WARRANTY MADE BY THE MANUFACTURER. IMPLIED WARRANTIES OF MERCHANTABILITY OR FITNESS FOR ANY PARTICULAR PURPOSE ARE LIMITED TO THE SAME ONE YEAR TERM AS THIS EXPRESS WARRANTY. UNDER NO CIRCUMSTANCES SHALL THE MANUFACTURER BE LIABLE FOR INCIDENTAL, CONSEQUENTIAL, SPECIAL OR CONTINGENT DAMAGES OR EXPENSES ARISING DIRECTLY OR INDIRECTLY FROM ANY DEFECT IN THE PRODUCT OR ANY COMPONENT OR FROM THE USE THEREOF. THE REMEDIES SET FORTH HEREIN ARE THE EXCLUSIVE REMEDIES AVAILABLE TO THE USER AND ARE IN LIEU OF ALL OTHER REMEDIES.

Some states do not allow limitations on how long an implied warranty lasts, and some states do not allow the exclusion or limitation of incidental or consequential damages, so the above limitations or exclusions may not apply to you.

2. This warranty does not include any charge for labor or installation.
3. This warranty does not extend to painted surfaces nor to damage or defects resulting from accident, alteration, misuse or abuse, or improper installation.
4. This warranty does not cover claims which do not involve defective workmanship or materials.

### DUTIES OF THE CONSUMER

1. The heating equipment must be installed by a qualified installer and operated in accordance with the installation and homeowner's instructions furnished with the equipment.
2. Any travel, diagnostic costs, service labor, and labor to repair the defective unit will be the responsibility of the owner.
3. A bill of sale, cancelled check, payment record or permit should be kept to verify purchase date to establish the warranty period.
4. Have the installer enter the requested information in the space below.

### GENERAL

1. The Manufacturer neither assumes nor authorizes any person to assume for it any other obligation or liability in connection with said equipment.
2. Service under this warranty should be obtained by contacting your dealer. Provide the dealer with the model number, serial number and purchase date verification.
3. If, within a reasonable time after contacting your dealer, satisfactory service has not been received, contact: Customer Service Department, 225 Acacia St., Colton, CA 92324, for assistance.
4. THIS WARRANTY GIVES YOU SPECIFIC LEGAL RIGHTS, AND YOU MAY ALSO HAVE OTHER RIGHTS WHICH VARY FROM STATE TO STATE.

### INSTALLATION INFORMATION

Model No. \_\_\_\_\_ Serial No. \_\_\_\_\_

Orig. Purchaser \_\_\_\_\_

Address \_\_\_\_\_

City and State \_\_\_\_\_ Zip \_\_\_\_\_

Dealer \_\_\_\_\_

Address \_\_\_\_\_

City and State \_\_\_\_\_ Zip \_\_\_\_\_

Installation date \_\_\_\_\_ Signed by \_\_\_\_\_ (Dealer or authorized representative who certifies that this appliance has been installed in accordance with Manufacturer's instructions and local codes.)

## A Word From The Manufacturer

Dear Customer,

To set up our furnace assembly procedures, several hundred quality assurance, safety audit and design performance tests have been conducted according to the standards provided by the American National Standards Institute, the Department of Energy and our certification agency — the American Gas Association Laboratories.

This was done to assure you of receiving the best value and most reliable appliance of its type available today.

We are confident that your Williams furnace can provide you years of low cost, efficient, heating comfort.

Thank you for purchasing a Williams furnace.

Sincerely,  
Employees of Williams Furnace Company

---

### Introduction

Please read our instructions before you install and use your furnace. This will help you obtain the full value from this furnace. It could help you avoid needless service costs, if the answer to the problem is found within this instruction manual.

---

### Basic Description

The direct vent wall furnace is shipped ready to install against an exterior wall not exceeding 12" in thickness. Furnace may also be recessed up to 10" in a wall with studs spaced 16" center-to-center.

Always consult your local heating or plumbing inspector, building department or gas utility company regarding regulations, codes or ordinances which apply to the installation of a direct vent furnace.

Air is drawn in at the top by the fan and discharged through a grille near the floor. A two-speed fan is used with Models 5507332, 6257732, 5507331, and 6257731. A single speed fan is used on all other models. The furnace contains a multi-slot burner (two on Models 5507332, 6257732, 5507331, and 6257731) and burns either natural or L.P. (liquefied petroleum) gas, depending on the model you have purchased.

The sealed combustion system draws combustion air directly from outdoors into the combustion chamber and combustion gases are discharged directly to the outdoors through tubes mounted to the rear of the furnace.

The furnace heat exchanger is built of heavy gauge steel treated for corrosion resistance. The fan at the top forces air down along the front, back and sides of the heat exchanger where it is discharged into the room. The furnace cabinet is also constructed of heavy gauge steel and has a enamel paint finish.

The furnace controls are located behind an access door on the lower front of the furnace. All models are equipped with American Gas Association listed gas valves and pilots. Models 4007332, 4007331, 5507332, and 5507331 are equipped with an electric ignition automatic pilot relight system.

---

### Optional Accessories

#### Side Outlet Grille Kit 6701

Lets you route some heated air to a second room. Mounts on side wall of second room and must be within 10 inches of wall furnace. See pages 7 & 10.

#### Diffuser Grille Kit 6703 or 6704

Lets you route some heated air in a two-way direction. Kit 6704 for one-way direction.

#### Side Grille Kit 6702

Lets you route some heated air to side of furnace in the same room. See pages 7 & 10.

#### Trim Strip Kit 4701

Provides finished edge at side of wall furnace. Neutral beige enamel steel.

#### Replacement Vent Cap Assembly 9801

Should for any reason your vent cap becomes damaged and its operation impaired, replace it immediately.

#### NOTE

Kits are identified on the carton by manufacturing number 6701, 6702, 6703 and 6704 are also listed on the furnace rating plate.

---

### Helpful Installation Information

The following booklets will help you in making the installation:

ANSI/NFPA 70-1990 or current edition "National Electrical Code." In Canada: CSA C22.1 Canadian Electrical Code.

American National Standard NFPA54/ANSI Z223.1 1988 or current edition "National Fuel Gas Code."

Obtain from — American National Standards Institute, Inc., 1430 Broadway, New York, N.Y. 10018.

In Canada: CAN/CGA B149 Installation Code.

## Safety Rules

### WARNING

READ THESE RULES AND THE INSTRUCTIONS CAREFULLY. FAILURE TO FOLLOW THESE RULES AND INSTRUCTIONS COULD CAUSE A MALFUNCTION OF THE FURNACE. THIS COULD RESULT IN DEATH, SERIOUS BODILY INJURY, AND/OR PROPERTY DAMAGE.

INSTALLATION MUST CONFORM TO LOCAL CODES. IN THE ABSENCE OF LOCAL CODES, INSTALLATION MUST CONFORM WITH THE NATIONAL FUEL GAS CODE, ANSI Z223.1. THE APPLIANCE, WHEN INSTALLED, MUST BE ELECTRICALLY CONNECTED AND GROUNDED IN ACCORDANCE WITH LOCAL CODES OR, IN THE ABSENCE OF LOCAL CODES, WITH THE CURRENT NATIONAL ELECTRICAL CODE ANSI/NFPA NO. 70.

### IN CANADA

1. INSTALLATION MUST CONFORM TO LOCAL CODES OR, IN THE ABSENCE OF LOCAL CODES, THE CURRENT CAN/CGA B149 INSTALLATION CODE.
2. THE APPLIANCE, WHEN INSTALLED, MUST BE ELECTRICALLY CONNECTED AND GROUNDED IN ACCORDANCE WITH LOCAL CODES OR, IN THE ABSENCE OF LOCAL CODES, WITH THE CURRENT CSA C22.1 CANADIAN ELECTRICAL CODE.
3. REFERENCE IS MADE IN THIS MANUAL REGARDING GAS TYPE AS L.P. BE ADVISED THAT L.P. IS NOT AVAILABLE IN CANADA, REFER TO PROPANE/L.P. GAS.

1. USE ONLY MANUFACTURER'S REPLACEMENT PARTS. USE OF ANY OTHER PARTS COULD CAUSE INJURY OR DEATH.
2. DO NOT install this furnace in an alcove.
3. DO NOT install these furnaces in a travel trailer, recreational vehicle or mobile home.
4. MAINTAIN all clearances specified in section "Locating Wall Furnace and Thermostat" and "Vent Installation."
5. BE SURE furnace is for type of gas to be used. Check the rating plate by the gas valve in the lower cabinet. Do not change it to use other gases. Unsafe operation could result and could cause bodily injury and death.
6. For Natural gas, the minimum inlet gas supply pressure for the purpose of input adjustment is 5" water column. The maximum inlet gas supply pressure is 7" water column.  
For L.P. gas, the minimum inlet gas supply pressure for the purpose of input adjustment is 11" water col-

umn. The maximum inlet gas supply pressure is 13" water column.

7. ANY SAFETY SCREEN, GUARD OR PARTS REMOVED FOR SERVICING AN APPLIANCE MUST BE REPLACED PRIOR TO OPERATING THE APPLIANCE TO AVOID PROPERTY DAMAGE, BODILY INJURY OR DEATH.
8. INSTALL the furnace vent directly to the outdoors, using the vent assembly supplied with the furnace, so that harmful gases will not collect inside the building.
9. PROVIDE FOR ADEQUATE COMBUSTION AIR around vent cap on outside, see Fig. 2, pg. 6 and adequate air circulation around cabinet inside the open room.
10. NEVER vent flue gases into another room, a fireplace or any space inside a building. This could cause property damage, bodily injury or death.
11. NEVER test for gas leaks with an open flame. Use soap suds to check all gas connections. This will avoid the possibility of fire or explosion.
12. ALLOW furnace to cool before servicing. Always shut off electricity and gas to furnace when working on it. This will prevent any electrical shocks or burns.
13. DUE TO HIGH TEMPERATURES, locate the furnace out of traffic and away from furniture and draperies.
14. ALERT children and adults to the hazards of high surface temperature and to keep away to avoid burns or clothing ignition.
15. CAREFULLY supervise young children when they are in the same room with the furnace.
16. DO NOT place clothing or other flammable material on or near furnace.
17. INSTALLATION and REPAIR must be done by a qualified service person. The appliance should be inspected before use and at least annually by a professional service person. More frequent cleaning may be required due to excessive lint from carpeting, bedding material, etc. It is imperative that control compartments, burners and circulating air passages be kept clean.
18. BEFORE INSTALLING: To avoid electrical shock, turn off electrical circuits that pass through the wall where you are going to install the furnace.
19. BE AWARE of good safety practices by wearing personal protective equipment such as gloves and safety glasses to avoid being injured by sharp metal edges in or around furnace and while cutting or drilling holes in wood and or sheet metal.
20. CAUTION: Label all wires prior to disconnection when servicing controls. Wiring errors can cause improper and dangerous operation. Verify proper operation after servicing.

### WARNING

DO NOT USE THIS HEATER IF ANY PART HAS BEEN UNDER WATER. IMMEDIATELY CALL A QUALIFIED SERVICE TECHNICIAN TO INSPECT THE HEATER AND TO REPLACE ANY PART OF THE CONTROL SYSTEM AND ANY GAS CONTROL WHICH HAS BEEN UNDER WATER.

## Unpack Your Furnace

The furnace is shipped in two cartons, one containing the furnace and the other containing the vent cap with inlet and vent tubes.

1. Lay carton horizontally. Open carton and remove top trim cover from its packing. Remove thumb screw at top of furnace, raise top front panel 1/2 inch and remove panel from cabinet.
2. Place these and other parts, as they are removed from furnace, where they cannot be lost or damaged before you need them.
3. Bottom front panel can be removed by grasping just below handle and pulling it outward and then upward. See Fig. 1.

### NOTE

Check the burner rating plate, located in burner compartment, to make sure your furnace is equipped to operate on the type of gas available (either Natural or L.P. Gas). DO NOT convert unit from natural gas to L.P. gas or from L.P. gas to natural.

4. Remove all literature and package containing thermostat, wire and metal anchors used for free standing installation.
5. Check the fan blade to be sure it spins freely.
6. Take out four screws holding fan shroud to side flanges of cabinet and remove shroud. See Fig. 1.

### NOTE

The fan blade must be removed in order to remove cardboard shipping brace located under motor.

7. Before removing the fan blade, remember its position by examining the blade nut and the amount of shaft visible. Scribe or mark the motor shaft in order to reinstall the fan blade to its original place on the shaft.

FIG. 1

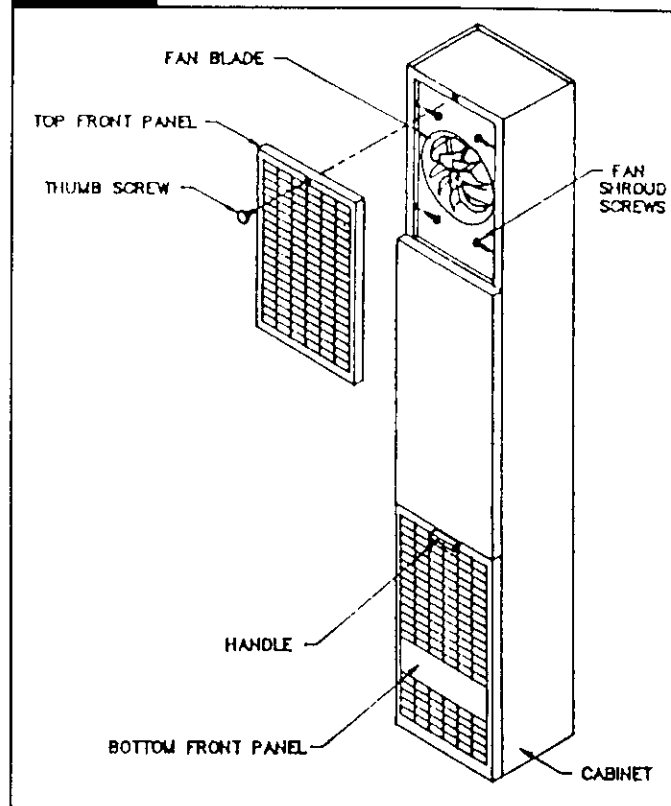

8. Loosen 1/8" "allen head" set screw holding fan blade to motor shaft and remove the fan. Place fan blade and fan shroud where they will not be damaged.
9. Remove cardboard shipping brace located under motor mounting brackets.
10. Future electrical connections will be made in this upper cabinet area, inside electrical junction box, behind transformer.
11. Properly dispose of shipping materials.

## Basic Tools Needed

Hand drill or properly grounded electric drill.  
Expansion bit 1/2" to 1-5/8" or 1/2" and 1 1/2" Blade bits  
1/8" and 3/16" drill bit (metal)  
6 ft. folding rule or tape measure  
Screwdriver (med. blade) and (Phillips head)  
Pliers (wire cutting)  
Hammer  
1/8" Allen wrench

Stud Locator or small finish nails  
Tin Snips  
8" adjustable wrench  
12" adjustable wrench  
Key hole saw or Sabre saw  
Hack saw  
2 - 10" or 12" pipe wrenches  
Gloves and safety glasses

## Basic Materials

Pipe and fittings to make connections to furnace. (Page 16).

Caulking Compound - Silicone Rubber with a temperature rating of 500°F.

DO NOT USE types advertised as paintable or for bath tub use as most contain fillers and will not withstand high temperatures.

Pipe Joint Compound resistant to L.P. gases.

Electrical wiring supplies as needed (See Page 17).

Minimum wire size is #14 gauge copper.

3/4" Quarter Round or other wood trim molding approx. 16' long or Trim accessory 4701.

2" x 4" x (length as required) Spacer Block (See Page 8).

1 x 1 wood strips if Optional Side Outlet Grille Kit 6701 is used.

# Installing Your Wall Furnace

The following steps are needed for proper installation and safe operation of your furnace. If you have any doubts as to any requirements, check with local authorities for local and state codes affecting the installation.

Obtain professional help where needed.

DO NOT install these furnaces in a travel trailer, recreational vehicle or mobile home.

## IMPORTANT

For satisfactory and trouble-free operation, be sure to:

1. Properly locate the furnace within the space to be heated.
2. Provide for adequate combustion air around vent cap on outside, see Fig. 2 and adequate air circulation around cabinet inside the open room.
3. Maintain minimum clearance: Floor 0" or ceiling 4", side wall 4". For exception to minimum side wall clearance, see Figs. 4, 5 & 6, pg. 7.

## Locating Wall Furnace & Thermostat

Consider the following points before attempting to install the furnace:

1. This is a direct vent wall furnace. It must be installed on an OUTSIDE WALL for proper venting of flue gases (Fig. 2).
  - a. Wall furnace can be surface mounted on an outside wall. (Surface Mount)
  - b. Ideally, the wall should be the least windy side of the dwelling, as strong gusts may extinguish the pilot.
  - c. Furnace may be installed flush against a wall or recessed up to 10" maximum. Wall thickness from back surface of furnace to outside of wall can be  $\frac{3}{4}$ " minimum to 12" maximum. See Fig. 3, pg. 7.

With standard furnace discharge outlet, do not install closer than 4" to intersecting wall. See Fig. 4, pg. 7.

Studs must be spaced on 16 inch centers or stud space will have to be framed in. See pg. 7, Recessed Mounting.

2. The top of the furnace must be at least 4 inches from the ceiling.
3. Check the clearances needed from the furnace and vent (Fig. 2 and Fig. 4, pg. 7). You must place the furnace where you will have no less than the clearances shown. See Fig. 5 & 6, Page 7.
4. When using optional kits 6703 or 6704, maintain the clearances as shown in Figs. 5 & 6, pg. 7.
5. When using optional kit 6701, maintain clearance as shown in Fig. 4, pg. 7. Use only optional outlet and grille kits available from manufacturer.
6. The outside vent cap must be at least 18 inches away from any window or other building opening (Fig. 2).
7. The furnace will not work if anything stops free entry of fresh air into the vent, or free flow of flue gases from it. Be sure the center of the vent cap is at least 18 inches above ground level or shrubs are as shown in Fig. 2, pg. 6. Make sure shrubs are kept trimmed. It must also be at least 18 inches from any overhang, wall, or other blockage.
8. Try to place the furnace near the center of the space to be heated for good air circulation. Do not put it behind a door or draperies. Do not put in a closet, alcove, hallway or other confined space.
9. Be sure that gas piping and electrical wiring can be brought to the furnace. See sections on gas piping and electrical wiring for your type of furnace mounting.
10. The bottom of the furnace must rest directly on a wood or concrete floor. If floor is other than wood or concrete, such as carpet or sheet vinyl flooring, there must be a piece of wood or sheet metal under the furnace that is at least the same size as the bottom of the furnace.

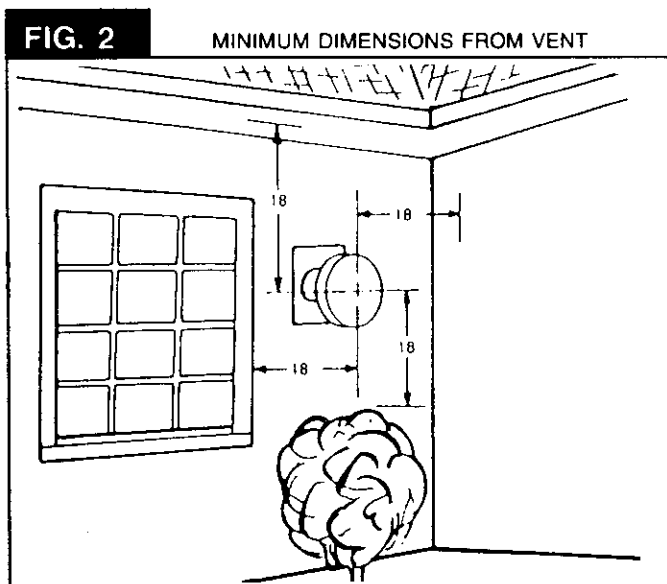

- d. If wall has a brick, block or other facing at least  $\frac{3}{4}$ -inch thick, the furnace can be mounted so it is recessed into the wall between standard 2 x 4 wall studs.

## WARNING

IF VINYL SIDING IS USED ON EXTERIOR WALL SURFACE, HEAT FROM VENT CAP COULD CAUSE DISTORTION/DISCOLORATION. SHIELD TO PROTECT SIDING. CHECK WITH MANUFACTURER FOR ADDITIONAL OPTIONS.

## Locating Wall Furnace & Thermostat (Con't)

10. Be sure to provide adequate clearance and service access. The front of the furnace must face the open room.
11. Choose a location for the thermostat about 5 feet above the floor on an inside wall. The thermostat wire supplied with your furnace is 20 feet long, which should be enough to run up through the attic of a single-story home, so the thermostat can be a maximum of 16 feet from the furnace measure in a straight line, or about 8 feet from the furnace if the wire is run under the floor. If more length is required, see note on page 11. The thermostat should be sensing average room temperature; avoid the following:
 

<b>HOT SPOTS:</b> Concealed pipes or ducts Fireplaces Registers TV sets Radios Lamps Direct sunlight Kitchen	<b>COLD SPOTS:</b> Concealed pipes or ducts Stairwells-drafts Doors-drafts Unheated rooms on other side of wall <b>DEAD SPOTS:</b> Behind doors Corners, and alcoves
--	---
12. After picking a location that meets the requirements, inspect the wall, floor and outside areas. Make sure there are no pipes, wiring, or anything else that would interfere with furnace or vent or thermostat installation. If required, move them or pick a new location.

**FIG. 3**

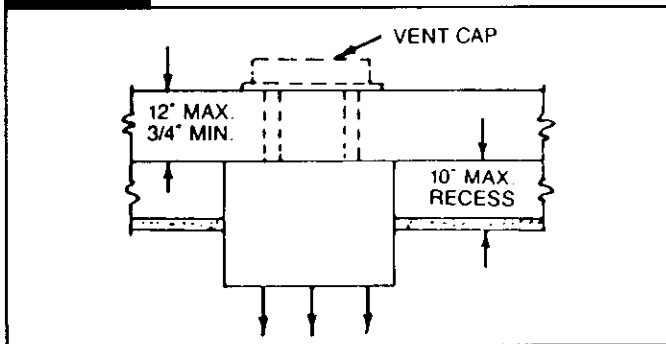

**RECESSED INSTALLATION CLEARANCE NOTE**

A portion of the furnace that is recessed into a wall up to 10" maximum recess may have (0) zero inch clearance to combustibles. (See Fig. 3). All other clearances for the unrecessed portion must be observed.

**FIG. 4**

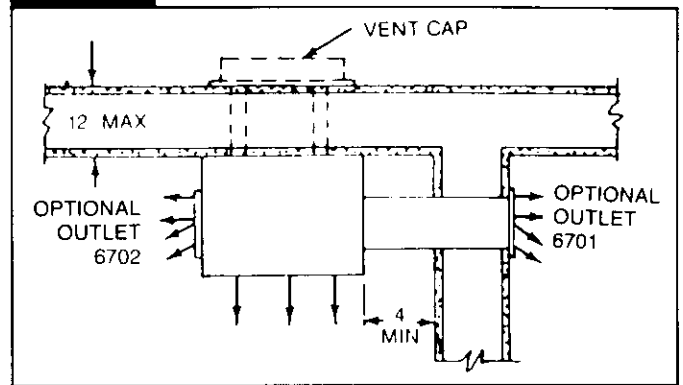

**FIG. 5**

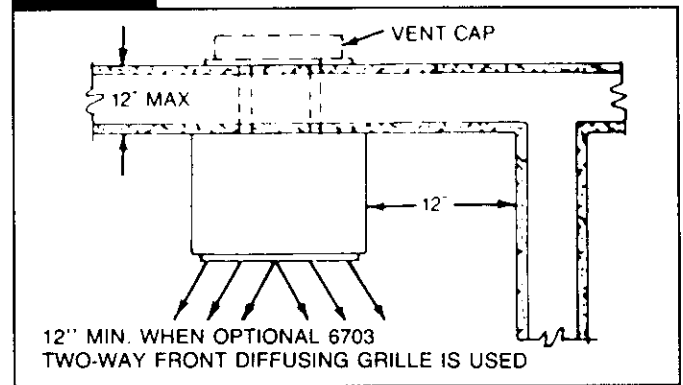

**FIG. 6**

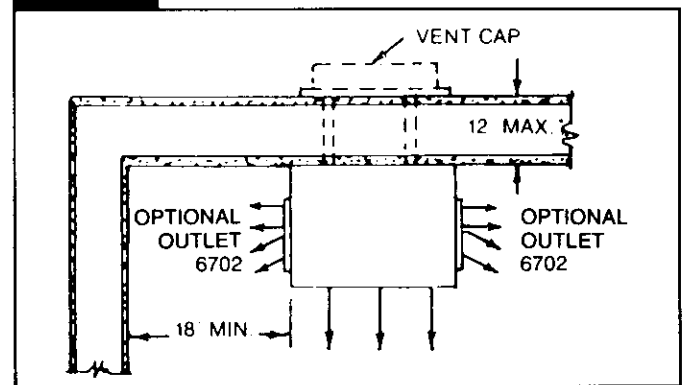

## Recessed Mount Installation

### FIND THE STUDS

Use a stud locator or small finishing nails. Repeatedly drive and remove a nail into the wall in the area of the stud until you find it. Then find one side. Leave the nail there. Drive another nail just on the other side of the same stud. Inside edge of the other stud should be about 14½ inches from the one found. Drive finishing nail on inside edge of this stud.

**NOTE**

IF STUDS ARE NOT ON 16 INCH CENTERS, SEE CLOSE OFF STUD SPACE, PAGE 8.

### CUT WALL OPENING

1. Lay out the required opening to be cut in inside wall (Fig. 7, pg. 8). Mark center of the vent hole on wall. Using a window, door or wall corner for reference, measure to find where vent will be on outside wall. Check to be sure clearances (Fig. 2, Fig. 4, Fig. 5 and Fig. 6) will be right.
2. Drill a ¼ inch hole through vent hole center to the outside wall to mark vent location.
3. Make the required cutout in inside wall. (Fig. 7, pg. 8)

## Recessed Mount Installation (Con't)

- Using the hole drilled through to the outside wall as the center, cut a 9 1/4 inch diameter hole for the vent. It may be better to work from outside, especially when breaking through brick, stone or tile. (See Fig. 7).
- In new stud wall construction, install blocks as shown in Figure 7 and install plaster grounds around inside of wall opening.
- The vertical height of the opening shown is 3 inches greater than height of furnace to allow space for connection of wiring after furnace is installed.

**NOTE**  
VERTICAL MEASUREMENTS ARE FROM FINISHED FLOOR. (Fig. 7)

**FIG. 7**

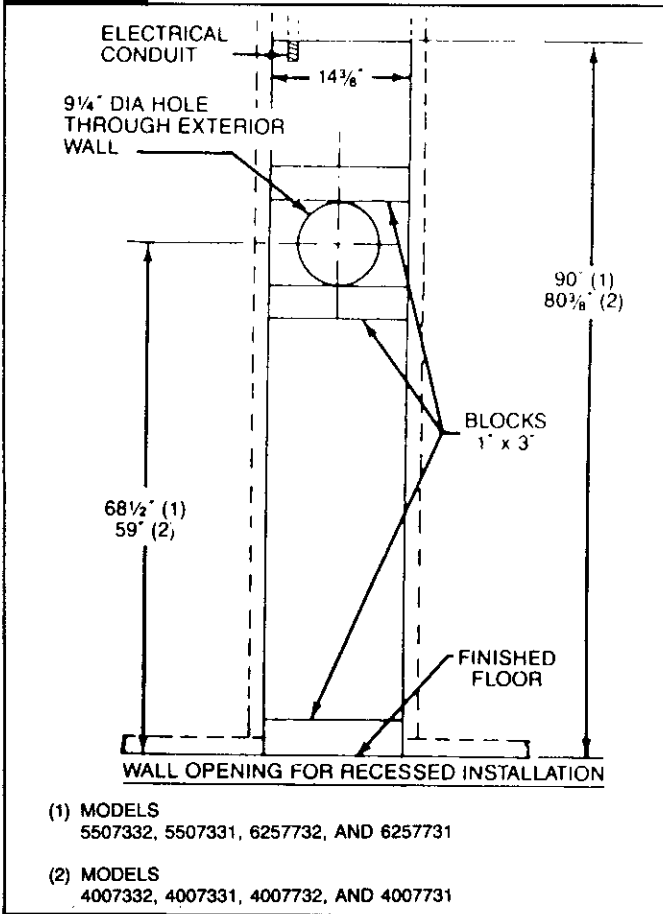

### CLOSE OFF STUD SPACE (If Required)

If studs are not on 16 inch centers, cut the hole for the furnace next to an existing stud and frame in the other side using a 2 x 4 and spacer blocks as required. Fig. 8.

If the distance from the top of the cutout to the ceiling wall plate is more than 18 inches, it is recommended that it be closed off.

Nail a 2 x 4 long enough to go between the studs at the top of the opening to close off the stud space.

**FIG. 8**

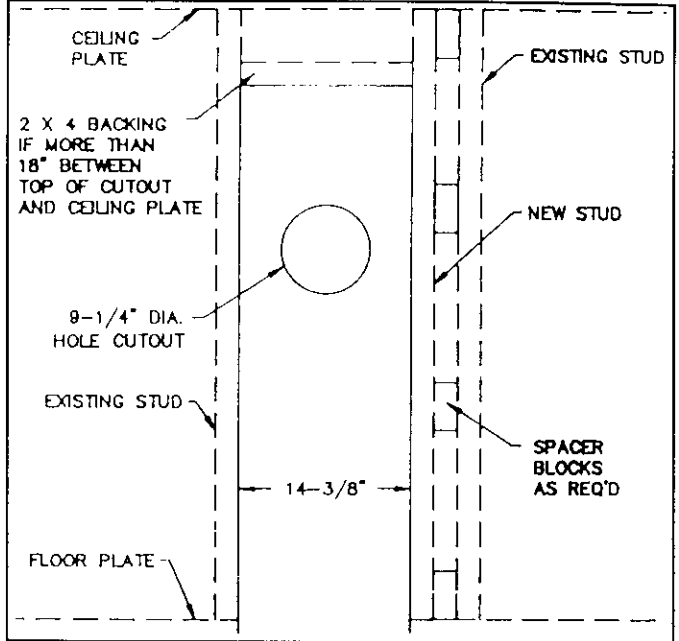

**FIG. 9**

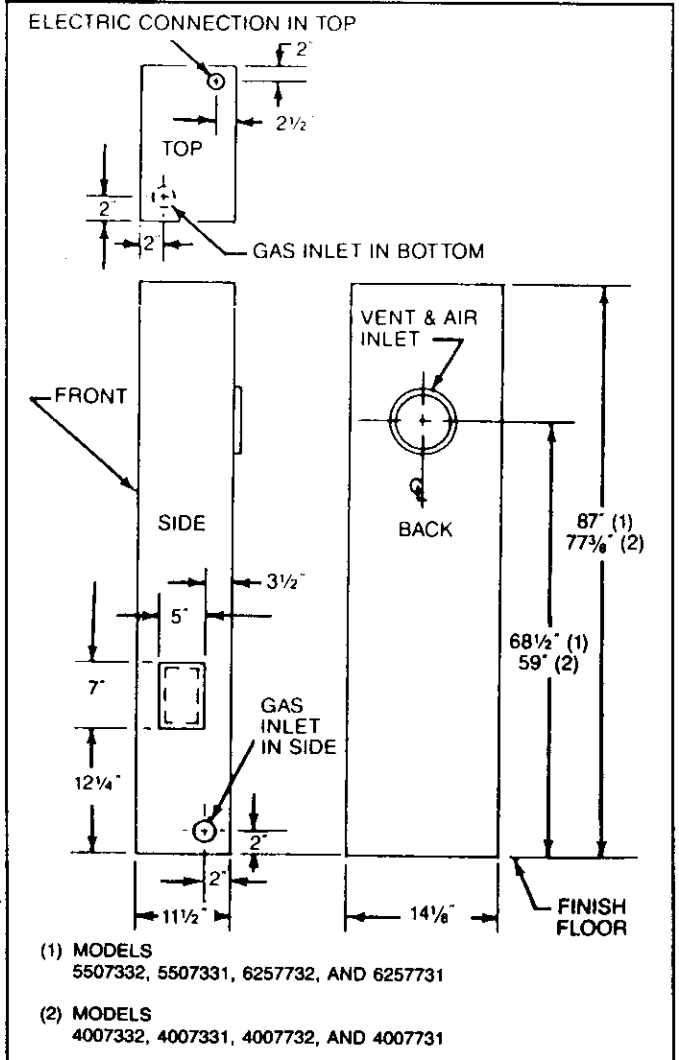



## Recessed Mount Installation (Con't)

### GAS AND ELECTRICAL SUPPLY OPENINGS

Holes must be drilled for the gas line and electrical supply. Holes must be located from each side of furnace as shown in Fig. 9, pg. 8.

Decide whether the gas line will come through the floor or wall.

Drill a 1½-inch hole in wall or floor as needed.

Gas lines can be run at this time or done after furnace is mounted, see section: Gas Supply and Piping, pg. 15.

The electrical supply opening should be at the upper left of the furnace, to match openings shown in Fig. 9, pg. 8. Mark ceiling wall plate and drill holes. If not practical to run wiring from the attic, drill holes through wall stud and

run wires up through adjoining stud space from crawl space or basement.

Run the electrical supply with ground wire and thermostat cable to the openings. Leave enough length to connect in the junction box after the furnace is installed. See section "Electrical Wiring," page 17.

### CAUTION

Do not run wire in any location where it might be damaged. Avoid splicing thermostat wire unless the spliced wires are properly cleaned, soldered, and taped.

## Offset Wall Installation

To mount the wall furnace on an offset wall, the area behind the furnace must be made flush or flat.

Use lumber (2 x 4's, 2 x 6's etc.) to furr the offset area to make the surface flush with other portion of wall.

Use sheet rock or paneling etc. to finish area.

Follow procedures under Surface Mount Installation.

## Surface Mount Installation

### FIND THE STUDS

1. Find two studs at spot where furnace is to be placed. Use a stud locator or small finishing nails. Repeatedly drive and remove a nail into the wall in the area of the stud until you find it. Then find one side. Leave the nail there. Drive another nail just on the other side of the same stud.
2. Inside edge of the other stud should be about 14½ inches from the one found. Drive finishing nail on inside edge of this stud.

### CUT VENT OPENINGS

1. Lay out and mark the center of the hole to be cut through the wall for the vent (Fig. 7, pg. 8). Using a window, door, or wall corner for reference, measure to find where vent will be on outside wall. Check to be sure clearances are correct. (Fig. 2, 4, 5 & 6, pgs. 6 & 7)
2. Drill a ¼-inch hole through vent hole center to the outside. Cut the 9¼-inch diameter hole through inside wall. Using the ¼-inch hole as the center, cut a matching hole in outside wall. It may be better to work from the outside, especially when breaking through brick, stone or tile.

### GAS AND ELECTRICAL SUPPLY OPENINGS

Holes must be drilled for the gas line and electrical supply. Holes must be located from each side of furnace as shown in Fig. 9, pg. 8.

Drill a 1½-inch hole in floor or wall for gas line.

Gas line can be run at this time or done after furnace is mounted, see section: Gas Supply and Piping, pg. 15.

Mark ceiling or wall to match wall furnace openings and drill a 1-inch hole for the power supply and a ½-inch hole for the thermostat cable. Run the electrical supply and ground wires to the opening. Leave enough length to connect in the junction box after the furnace is installed. See section "Electrical Wiring," pg. 17.

FIG. 10

WALL OPENING (SURFACE MOUNT)

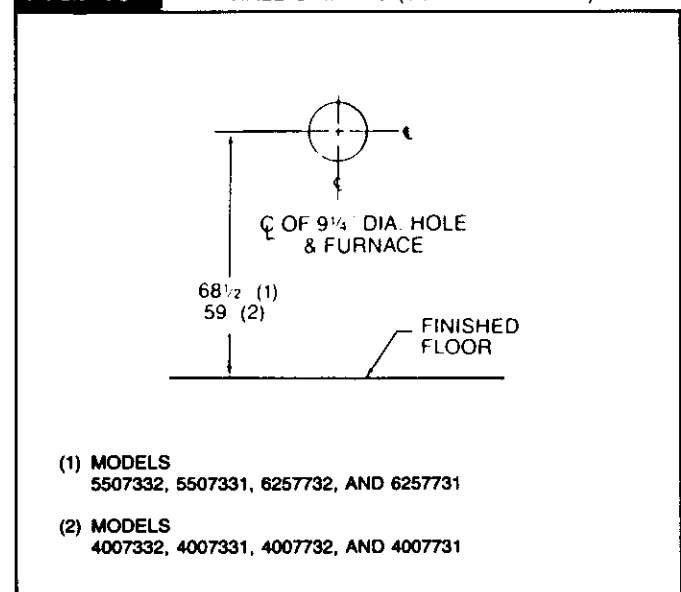

## Surface Mount Installation (Con't)

### ROUGH-IN OPTIONAL SIDE OUTLET NO. 6701

Install plasterground as shown in Figs. 11 & 12. Flanges of plasterground extend the thickness of normal plaster. If "dry-wall" or other thin material, flanges must be trimmed off flush with wall surface.

Follow measurements given carefully, and note that when a side outlet is used, the furnace casing must be exactly 4 inches from surface of adjacent wall except minimum clearance may be  $\frac{3}{4}$ -inch when optional 1-way Diffusing Grille Kit 6704 is used.

**FIG. 11**

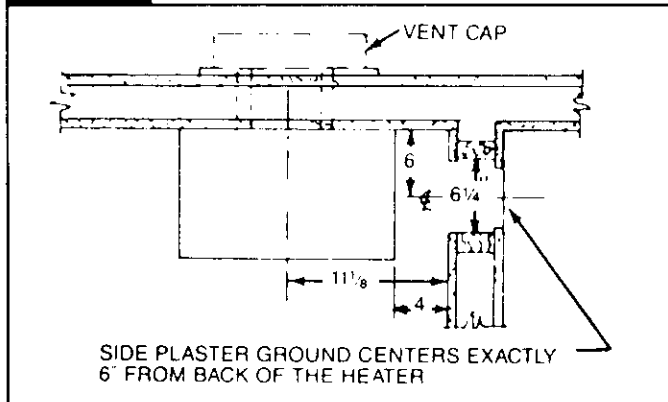

**FIG. 12**

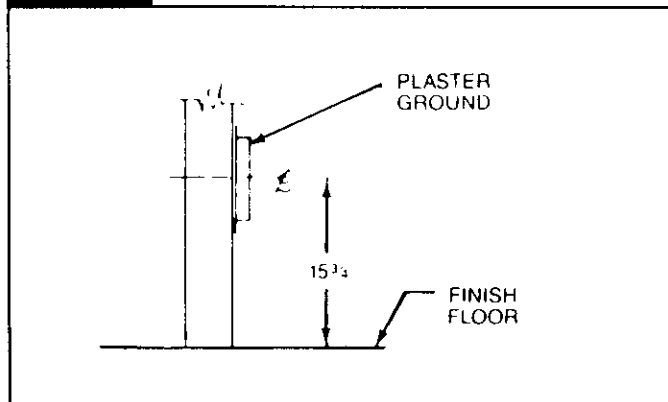

### MOUNTING OPTIONAL SIDE OUTLET GRILLE KIT NO. 6701

Refer to Fig. 13.

1. Before setting furnace into position, cut 5 x 7 rectangular opening in furnace outer casing where marked. See Fig. 9, pg. 8.
2. Place outer boot against casing with inner flanges exactly on edges of cut hole, mark screw location, remove boot and drill #33 holes for sheet metal screws.
3. Remove knockout plate and knockouts for screws from inner liner.
4. Secure 1 x 1 wood strip (not included with this kit) to wall next to side outlet as a backup for metal filler strips.

5. Fasten metal filler strips to side of furnace casing with front surface exactly opposite front of wood backup strip.
6. After furnace is placed in position, pass outer boot through plasterground tight against furnace casing. Then mark and cut off outer end flush with wall surface.
7. Press inner boot against liner, mark and cut off flush with wall surface. Install outer boot first, then inner boot, fastening through all holes with screws provided.

**FIG. 13**

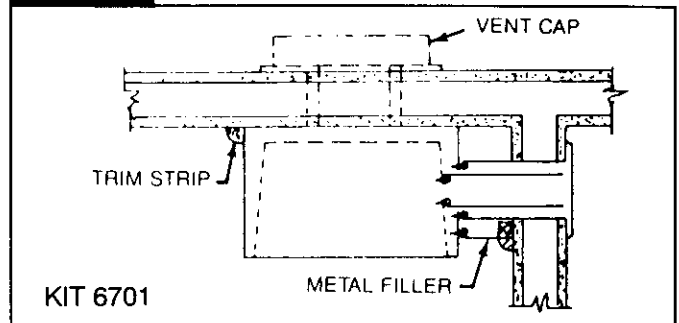

### OPTIONAL 2-WAY DIFFUSING GRILLE KIT NO. 6703

Refer to Fig. 14.

#### CAUTION

For use only in conjunction with a front outlet when the furnace is spaced at least 12 inches from an intersecting wall (see Fig. 5, pg. 7).

Metal clips on backside of optional grille snap into side louvers of front warm air outlet. Adjust clips with pliers if necessary. Grille may also be attached with sheet metal screws.

### 1-WAY FRONT DIFFUSING GRILLE KIT NO. 6704

Follow instructions for 2-WAY FRONT DIFFUSING GRILLE 6703 ABOVE, except furnace clearance to an adjacent wall may be  $\frac{3}{4}$ -inch minimum.

#### CAUTION

Use only optional kits available from the manufacturer.

**FIG. 14**

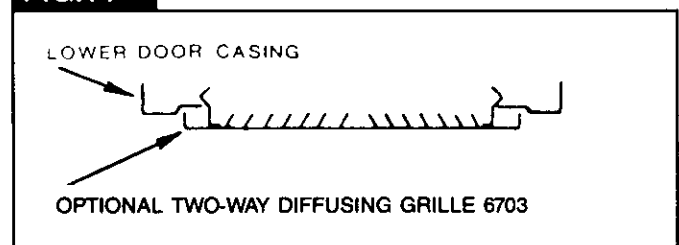

# Thermostat Installation

1. If an old thermostat is being replaced and is in a satisfactory location and the wiring appears to be in good condition, use existing wiring. If in doubt, use new wire.
2. If a new location is chosen or if this is a new installation, thermostat cable must first be run to the location selected. All wiring must agree with local codes and ordinances. These instructions cover bringing the wire down from the attic but it can be run from a basement or crawl space using similar methods.
3. Before drilling hole in wall at selected location, drive a small finishing nail through the ceiling in the corner of the wall and ceiling above the thermostat location. Pull the nail out and push a small stiff wire through the hole so it can be found in the attic. Drill a 1/2-inch hole through the ceiling wall plate.
4. Probe for obstructions in the partition. Then drill a 1/2-inch hole through wall at selected location for thermostat.
5. From the attic, feed the thermostat cable or a stiff wire through wall until even with thermostat location.
6. Snag thermostat cable through hole and pull cable through hole in wall so that 6 inches of cable protrudes.
7. Route cable to wall furnace.

## MOUNTING THE THERMOSTAT

1. To remove thermostat cover, squeeze cover and pull straight outward (see Fig. 27, page 18). Carefully remove and discard the packing tab protecting the switch contacts.
2. Connect thermostat wires to the terminal screws on the thermostat base. Make sure wiring does not interfere with thermostat operation.
3. Push any excess wire back through hole in wall and plug hole with insulation to prevent drafts from affecting thermostat operation.
4. Being sure to level thermostat for best appearance, fasten thermostat base to wall through mounting holes with screws provided.
5. Replace the thermostat cover.

## THERMOSTAT HEAT ANTICIPATOR

### SET THE THERMOSTAT HEAT ANTICIPATOR

A simple method of setting the heat anticipator in a 24-volt thermostat (without an A.C. ammeter) is to first read the label on the gas control valve and match its rating.

Example: If the ampere draw for the valve is .5 amps, set thermostat heat anticipator at the same setting (.5).

### ADJUST THERMOSTAT ANTICIPATOR

Refer to Fig. 16, Page 12.

Many factors affect this setting — room size, length of thermostat wire, thermostat location, etc. Additional small adjustment to increase or decrease heating cycles (4-6 per hour typical) may be required. If an A.C. ammeter is available, see instructions supplied with thermostat.

FIG. 15

ROUTE THERMOSTAT CABLE

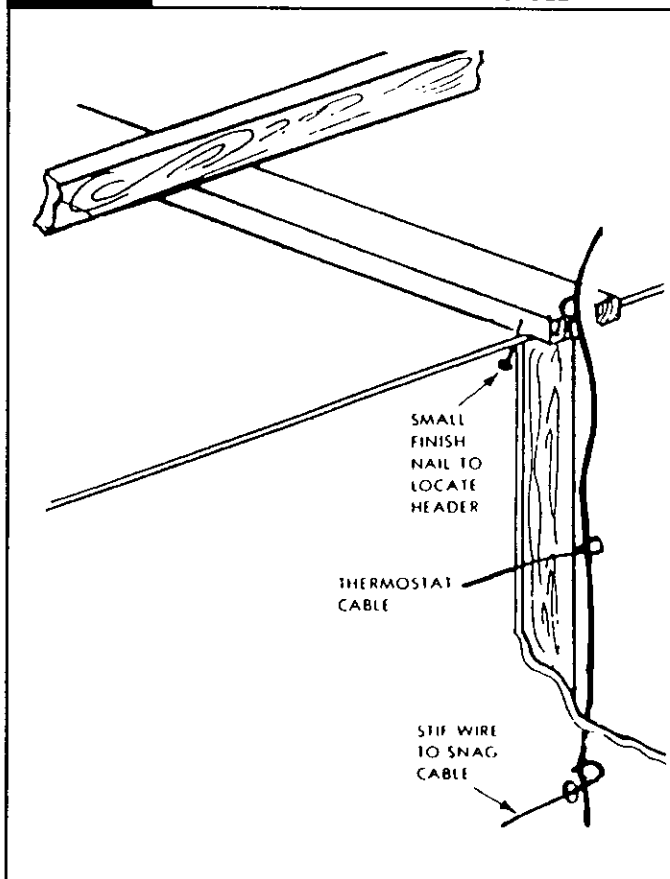

### NOTE

For longer "ON" times move the anticipator clockwise. For shorter "ON" times move the anticipator counter clockwise.

### NOTE

Use heavier wire size if more than 20 ft. of wire is required.

### NOTE

Refer to installation instructions packed in the thermostat carton if you have any doubt about the above procedures.

## Thermostat Installation (Con't)

**FIG. 16**

HEAT ANTICIPATOR — TYPICAL

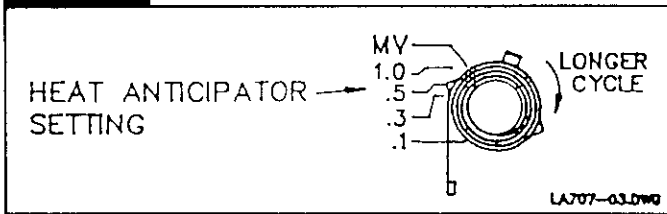

When all is adjusted properly, the furnace burner should shut off slightly before the desired room temperature is reached. The stored heat in the appliance is enough to bring room temperature up to desired level. The heat anticipator thus makes it possible to maintain very close temperature control.

## Vent Installation

### WARNING

DANGER OF PROPERTY DAMAGE,  
BODILY INJURY OR DEATH.  
PROPER VENT INSTALLATION IS CRITICAL TO  
THE SAFE OPERATION OF THE FURNACE.  
THEREFORE, CAREFULLY READ AND FOLLOW  
ALL THE INSTRUCTIONS GIVEN IN THIS  
SECTION.

The following instructions are for either surface or recess mounted wall furnace.

USE ONLY THE VENT ASSEMBLY SUPPLIED.

### IMPORTANT

ALL JOINTS IN THE INLET AND VENT TUBES AND  
ALL GASKETS MUST BE TIGHT.  
INSTALLATION IN ANY OTHER MANNER VOIDS  
THE A.G.A. DESIGN CERTIFICATION AND WILL  
AFFECT THE WARRANTY.

Refer to Fig. 18, pg. 13 for the name and location of the vent parts.

### DETERMINE PROPER LENGTHS

### IMPORTANT

To prevent harmful flue gases from entering the house, make sure NOT to trim air or vent tubes shorter than specified below.

Air inlet air tube 'A' and vent tube 'B' are supplied in lengths to handle wall thickness up to 12 inches.

To find the correct vent and air tube length, measure exact distance 'X' between surface on which back of cabinet will rest (inside of recessed cavity or face of wall when freestanding) and the outside wall surface. See Figs. 17 & 18 - pg. 13.

Inlet air tube 'A' — Add 7/8 inch to dimension 'X'. Mark on tube starting from end with collar and holes. Cut off evenly. File off any burrs resulting.

Vent tube 'B' — Add 2-1/8 inches to dimension 'X'. Mark on tube starting from end with collar and holes. Cut off evenly. File off any burrs resulting.

CUT ONLY THE PLAIN END (WITHOUT FLANGE) OF THE TUBES. MAKE A SQUARE CUT TO EXACT LENGTH.

**FIG. 17**

WALL THICKNESS

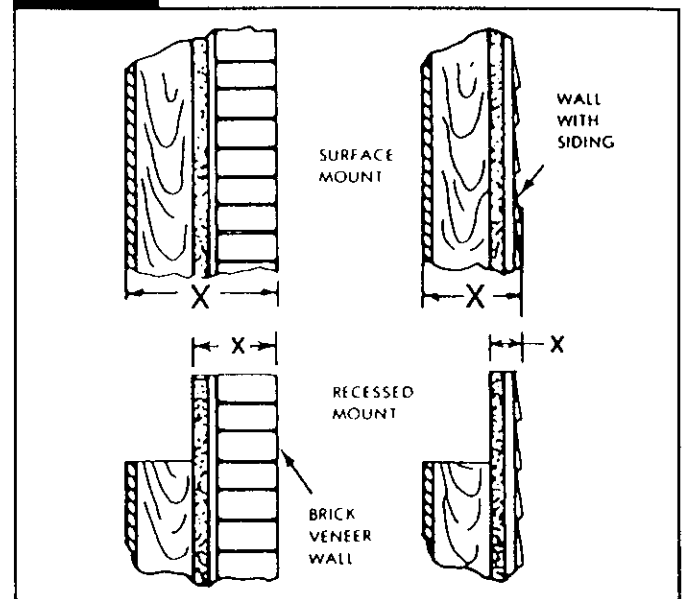

### HELPFUL CUTTING HINT

To make a straight cut, measure from the end and mark tube in several places. Align a piece of tape with the marks and wrap around the tube. Use the edge of the tape as a guide to help keep the cut straight.

### ATTACHING TUBE TO FURNACE

The smaller diameter vent tube (Fig. 18—"B", pg. 13) must be installed first.

The easiest way to install the vent tubes and get the gaskets positioned properly is to have the furnace lying front down on a flat surface.

### IMPORTANT

Be sure not to use longer screws than specified, as this could keep the furnace from functioning properly.

1. Attach vent tube (Fig. 18—"B", pg. 13) and gasket to the back of the furnace heat exchanger with (8) #8 x 3/8 inch sheet metal screws provided.
2. Attach air tube (Fig. 18—"A", pg. 13) and gasket to the back of the furnace casting with (8) #8 x 3/8 inch sheet metal screws provided.

## Vent and Inlet Tube Installation (Con't)

### NOTE

Each tube must overlap the collars of the vent cap a minimum of 1 1/4 inch, which is obtained when tubes are cut correctly as previously described.

**FIG. 18**

### VENT INSTALLATION

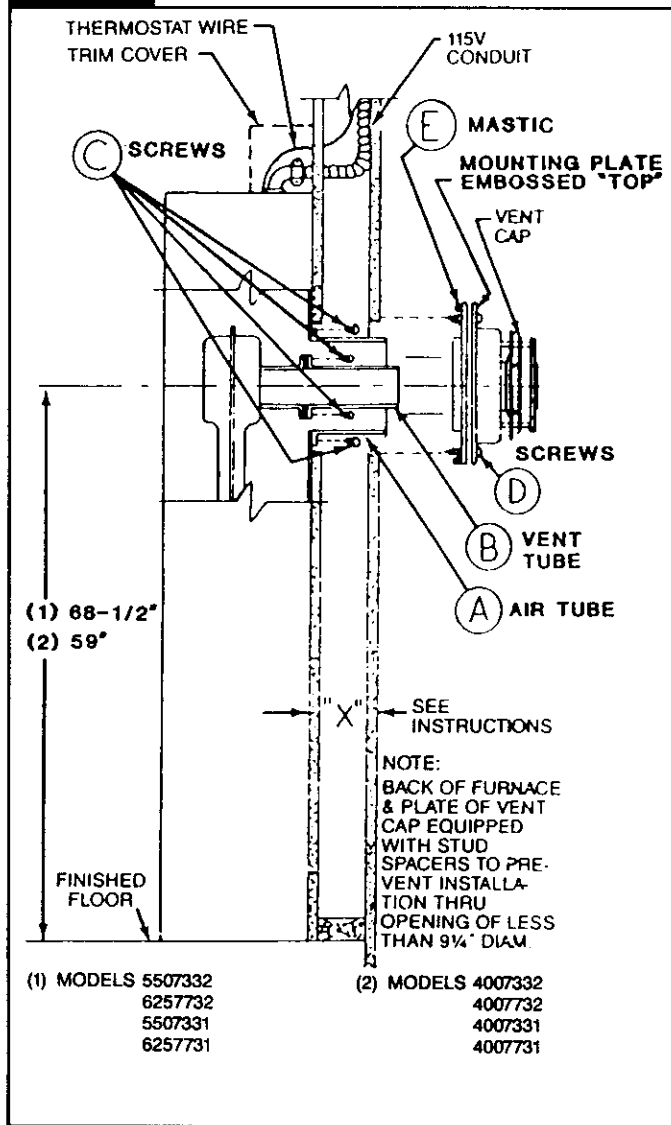

## Trim

To conceal the space between the furnace and wall, use 4701 Trip Strip Package (not furnished with furnace), 3/4 quarter round or other wood trim.

### TRIM COVER

Place trim cover on top of furnace. See Fig. 19. Drill through top casing flange and fasten through each side with a sheet metal screw. This plate covers the space between the top of the furnace and wall opening after electrical connections are made.

### MOUNT FURNACE THROUGH WALL

Mount the furnace through the wall using surface or recessed mounting instructions. See pgs. 7-10.

Refer to Fig. 18 for the following steps.

1. Check to see that the air tube protrudes through wall 7/8 inch min. to 1 inch max. for proper seal in vent cap.
2. Check to see that the vent tube protrudes past the air tube 1/8 inch min. to 1/4 inch max. for proper seal in vent cap.
3. Apply a single strip of mastic "E" provided in vent cap carton, continuously around the outer edge of the vent cap mounting plate.
4. Holding the vent cap in an upright position (embossed "top" on mounting plate towards top of furnace), push into place until stops are contacted. If stops prevent mounting plate from reaching wall, refer back to "DETERMINE PROPER LENGTHS" pg. 12.

### NOTE

The smaller tube in vent cap must slide over vent "B".

5. Fasten the vent cap mounting plate to wall with (4) 1 1/2-inch wood screws "D" provided.
6. On masonry construction, drill into wall and use plugs or anchors. Additional sealant (silicone) may be required if the mounting surface is uneven.

**FIG. 19**

### FURNACE ITEM

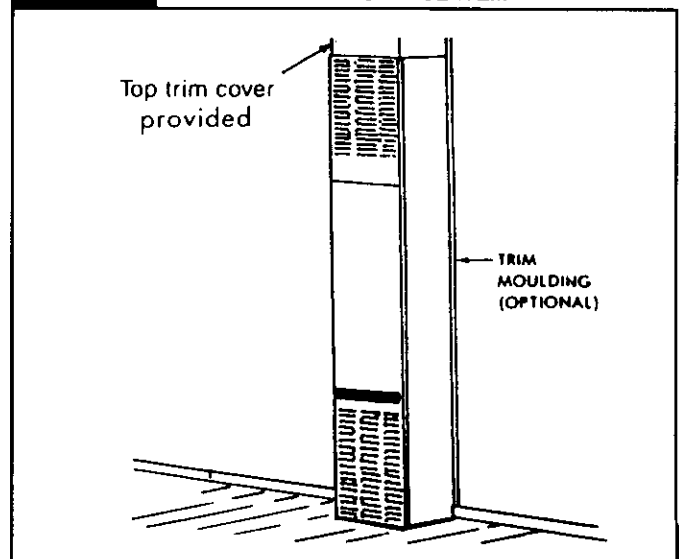

# Mounting Your Furnace

To obtain adequate clearance for fastening furnace or to install gas supply fittings, it may be necessary to remove the burner and control assembly as follows:

## CAUTION

Be careful not to damage burner pan gasket when removing burner and control assembly.

1. Lay the furnace on its back for the following steps.

Remove burner compartment door by pulling door top out and up.

### MODELS 4007332, 6257332, 4007331, 5507331.

- a. Remove screws holding ignition control unit and cover to casing.
- b. Remove (3) screws 'A' holding burner pan to upper heating element support (Fig. 21, pg. 15). Rotate burner pan toward front until (3) pins 'B' disengage from upper heating element support.
- c. Remove necessary wire to free control module from its mounting location. Mark or tag each wire removed for its exact reconnection (Fig. 22, pg. 15).
- d. Remove burner and control assembly from furnace.

### MODELS 4007732, 6257732, 4007731, 6257731.

- a. Remove manual spark ignitor and bracket by removing (2) screws and disconnecting wire at back of ignitor.
- b. Disconnect two (2) slip-on connectors (24 volt wires) from the gas valve.
- c. Remove (3) screws 'A' holding burner pan to upper heating element support (Fig. 21, pg. 15). Rotate burner toward front until (3) pins 'B' disengage from upper heating element support slots.
- d. Remove burner and control assembly from furnace.

## NOTE

Attach vent tubes **BEFORE** mounting furnace. See pgs. 12 & 13.

2. If furnace is recessed in wall, clear recess of all debris.
3. Be sure that gas is shut off at meter.
4. Before placing furnace in position, remove gas piping stub if necessary to locate furnace.
5. After installing vent tubes, carefully move furnace into position being sure not to bend the vent tubes.

## FASTEN FURNACE BOTTOM (Surface and Recessed Mount)

### NOTE

Fasteners are not furnished because of different requirements of various types of wall construction.

Fasten furnace to floor through holes provided in furnace bottom. If you have concrete flooring, use an alternate fastening method. See Fig. 20.

If furnace burner and control assembly were removed, replace by reversing steps 1a through 1d.

### IMPORTANT

When replacing burner and control assembly, be sure that pins "B" all enter slots in upper heating element support. To prevent damage to wire, be careful not to pinch them between furnace components and route them away from burner pan surface.

## FASTEN FURNACE TOP (Surface Mounting)

Fasten furnace top to wall using (2) metal anchors (packed in plastic bag with thermostat) by placing them over the back flange of furnace top and screwing to wall. See Fig. 20.

FIG. 20

FURNACE MOUNTING

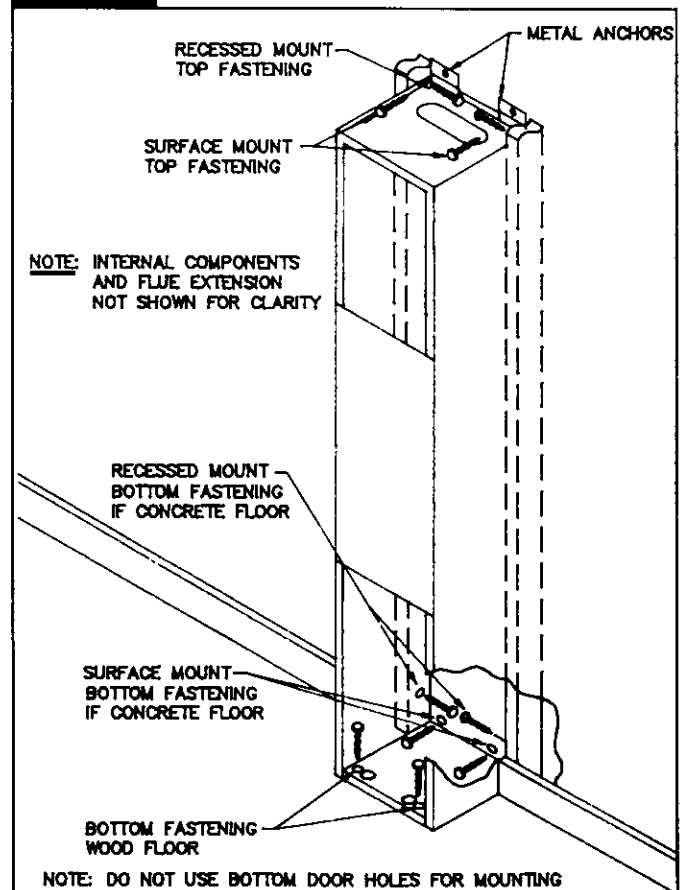

## Mounting Your Furnace (Con't)

### FASTEN FURNACE TOP (Recessed Mounting)

Fasten furnace top by drilling (2) holes through side flange furnace top and securing with (2) screws or nails to wall studs. See Fig. 20, pg. 14.

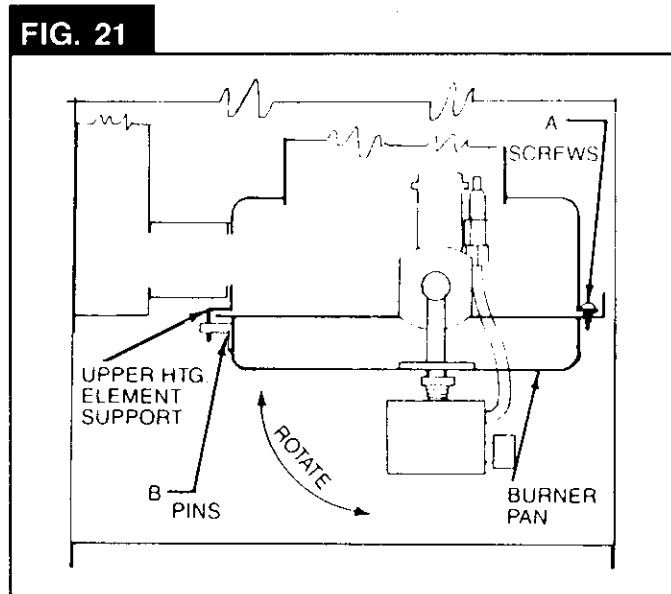

**CAUTION**  
Be careful not to damage furnace components or wiring when drilling holes.

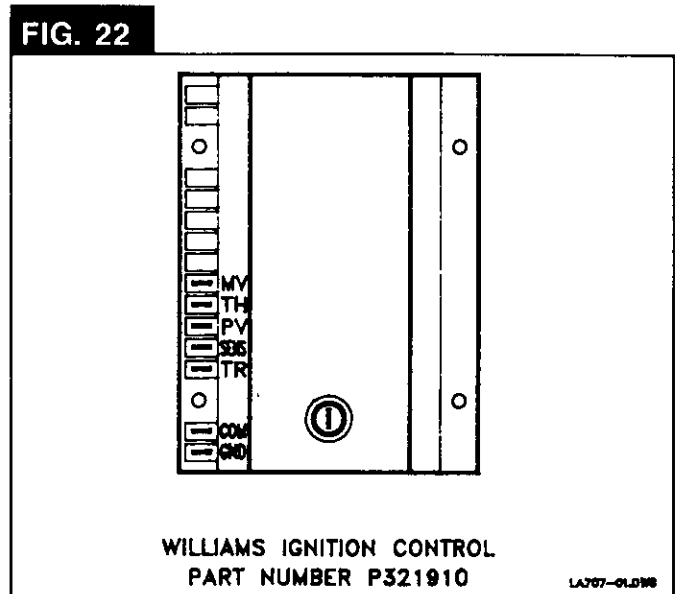

## Gas Supply and Piping

Gas control valve, within the furnace, is shipped with a seal cover gas inlet tapping. Do not remove seal until ready to connect piping.

### WARNING

**DANGER OF PROPERTY DAMAGE,  
BODILY INJURY OR DEATH.**

MAKE SURE THE FURNACE IS EQUIPPED TO OPERATE ON THE TYPE OF GAS AVAILABLE. MODELS DESIGNATED AS NATURAL GAS ARE TO BE USED WITH NATURAL GAS ONLY. FURNACE DESIGNATED FOR USE WITH LIQUEFIED PETROLEUM (L.P.) GAS HAVE ORIFICE SIZED FOR COMMERCIAL PURE PROPANE GAS. THEY CAN NOT BE USED WITH BUTANE OR A MIXTURE OF BUTANE AND PROPANE.

### GAS SUPPLY

For Natural gas, the minimum inlet gas supply pressure for the purpose of input adjustment is 5" water column. The Maximum inlet gas supply pressure is 7" water column.

For L.P. gas, the minimum inlet gas supply pressure for the purpose of input adjustment is 11" water column. The maximum inlet gas supply pressure is 13" water column.

Gas pressures and input to the burners must not exceed the rated input and pressure shown on the rating plate. On Natural Gas, the manifold pressure should be 4 inches water column. The manifold pressure should be 10.5 inches water column for L.P. Gas See pg. 18 for operation above 2000 feet altitude.

Orifice change may be required to suit gas supplied. Check with your local gas supplier.

### ORIFICE SIZES

Furnace Technical Information, Page 26, shows the correct orifice sizes for the different input ratings when using Natural or L.P. Gas.

### GAS PIPING

The gas supply line must be of an adequate size to handle the BTU/HR requirements and length of the run for the unit being installed.

Determine the minimum pipe size from Fig. 25, pg. 16, basing the length of the run from the gas meter or source to the unit.

All piping must comply with local codes and ordinances or with the National Fuel Gas Code (ANSI Z223.1-1988), whichever applies. In Canada: Follow CAN/CGA B149 Installation Code.

Refer to Fig. 23, pg. 16 for the general layout at the unit. It shows the basic fittings needed.

The following rules apply:

1. Use new, properly reamed pipe free from chips such as steel or black iron pipe and fittings or other approved by local codes.
2. Do not thread pipe too far. Valve distortion or malfunction may result from excess pipe within control. Apply moderate amount of good quality dope to pipe only, leaving 2 end threads bare. If LP gas installation, use compound resistant to action of liquefied petroleum gases.
3. Use ground joint unions.

## Gas Supply and Piping (Con't)

4. Install a drip leg to trap dirt and moisture before it can enter the gas valve. Drip leg must be a minimum of 3 inches long.
5. Install a manual shut-off valve.
6. Provide a 1/8 NPT test gauge connection immediately before the gas supply connection to the furnace.

**FIG. 23**

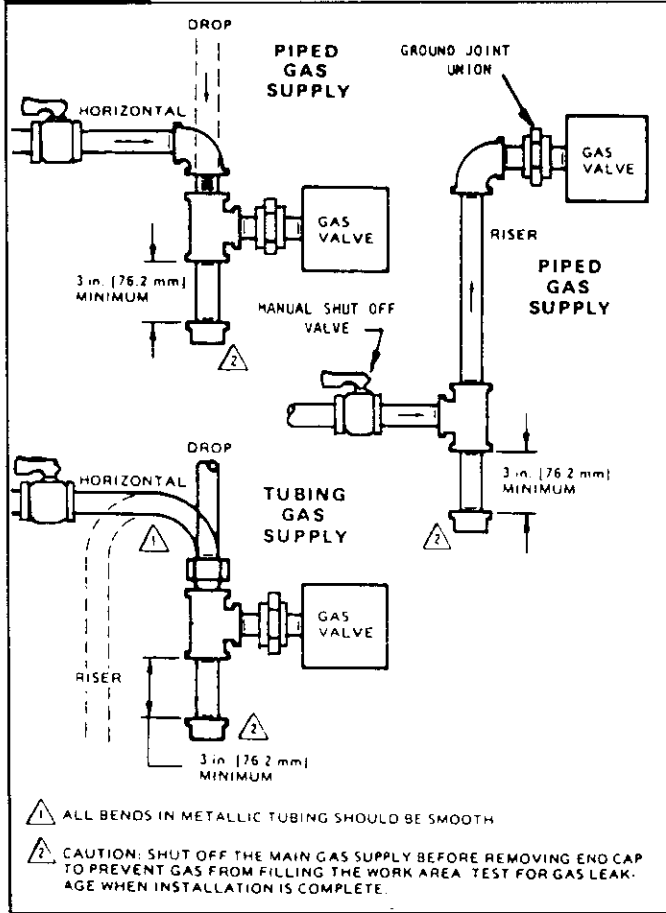

**FIG. 24**

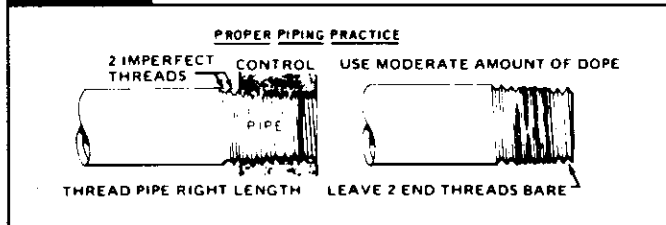

### GAS CONNECTION

If installation is for L.P. Gas, have L.P. installer use two-stage regulation and make all connections from storage tank to furnace.

Use two pipe wrenches when making the connection to the valve to prevent turning or damage to gas valve.

Connection between shutoff valve and burner control assembly can be made with an A.G.A./C.G.A. design certified flexible connector if allowed by local codes.

Tighten all joints securely.

### CHECKING THE GAS PIPING

Test all piping for leaks. When checking gas piping to the furnace with gas pressure less than 1/2 PSI, shut off manual gas valve for the furnace. If gas piping is to be checked with the pressure at or above 1/2 PSI, the furnace and manual shut off valve must be disconnected during testing. (SEE WARNING BELOW.) Apply soapsuds (or a liquid detergent) to each joint. Bubbles forming indicates a leak. Correct even the slightest leak at once.

**FIG. 25**

**GAS PIPE SIZES**

LENGTH OF PIPE-FT.	NATURAL GAS PIPE CAPACITY - BTU PER HOUR (INCLUDES FITTINGS) PIPE SIZE.		
	1/2"	3/4"	1"
20	92,000	190,000	350,000
40	63,000	130,000	245,000
60	50,000	105,000	195,000
LENGTH OF PIPE-FT.	L.P. GAS PIPE CAPACITY - BTU PER HOUR (INCLUDES FITTINGS)		
	1/2"	3/4"	1"
20	189,000	393,000	732,000
40	129,000	267,000	504,000
60	103,000	217,000	409,000

### WARNING

**DANGER OF PROPERTY DAMAGE,  
BODILY INJURY OR DEATH.**

**NEVER USE A MATCH OR OPEN FLAME TO TEST FOR LEAKS. NEVER EXCEED SPECIFIED PRESSURES FOR TESTING. HIGHER PRESSURES MAY DAMAGE THE GAS VALVE AND CAUSE OVERFIRING WHICH MAY RESULT IN HEAT EXCHANGER FAILURE. LIQUID PETROLEUM (L.P.) IS HEAVIER THAN AIR AND IT WILL SETTLE IN ANY LOW AREA, INCLUDING OPEN DEPRESSIONS AND IT WILL REMAIN THERE UNLESS AREA IS VENTILATED.**

**NEVER ATTEMPT STARTUP OF UNIT BEFORE THOROUGHLY VENTILATING AREA.**



# Electrical Wiring

## WARNING

DANGER OF PROPERTY DAMAGE,  
BODILY INJURY OR DEATH.

TURN OFF ELECTRIC POWER AT FUSE BOX  
OR SERVICE PANEL BEFORE MAKING ANY  
ELECTRICAL CONNECTIONS.

INSULATE WHERE NECESSARY.

ALL LINE VOLTAGE AND GROUND CONNEC-  
TIONS MUST BE COMPLETED BEFORE  
ELECTRICAL POWER IS RESTORED.

All electrical work must conform to your local codes and ordinances or in their absence, with National Electrical Code, ANSI/NFPA 70. If you are not familiar with wiring codes, in general, have a competent electrician do this job. In Canada: Follow C22.1, Canadian Electrical Code.

## CAUTION

Label all wires prior to disconnection when servicing controls. Wiring errors can cause improper and dangerous operation. Verify proper operation after servicing.

## JUNCTION BOX

Power supply connections are made inside the junction box in the upper left corner of the cabinet. See Fig.26.

## CAUTION

Do not connect 115V service line to the gas control valve or wall thermostat.

## ELECTRICAL CONNECTION

Connect 115V. conduit to top of furnace as shown in Fig. 18, pg. 13. Remove screws holding junction box cover and transformer for access to junction box. Remove the cover plate with transformer attached.

Pull supply wires through conduit and into junction box. Attach your 115V. supply wire to "LINE" factory wires. Use wire nuts provided.

Replace junction box cover and make final ground connections with screws for plate cover.

Refer to paragraph covering GAS AND ELECTRICAL SUPPLY OPENINGS, pg. 9. Follow Wiring Diagrams, pgs. 27 and 28.

If you have any doubt regarding electrical hookup, or compliance with code or ordinance, consult your electrical inspector or a licensed electrician.

## HELPFUL HINT

After wire nuts are screwed to wires, a small strip of electrical tape can be applied over wire nut at its base and onto wires to make a very solid connection.

## GROUNDING

A ground lug is installed for the ground connection. Use a copper conductor (#AWG) from the unit to a grounded connection in the electric service panel or a properly driven and electrically grounded ground rod.

## ELECTRICAL POWER SUPPLY

A branch circuit including this furnace must not exceed 15 amperes or run a separate 115V., 60 Hz., 15 Ampere circuit from a separate circuit breaker or fuse in your service panel to the furnace junction box. Do not run supply wires inside the furnace cabinet, except from the top of cabinet down to junction box. Connect as shown in Fig. 26.

FIG. 26

CONNECTING SUPPLY WIRING

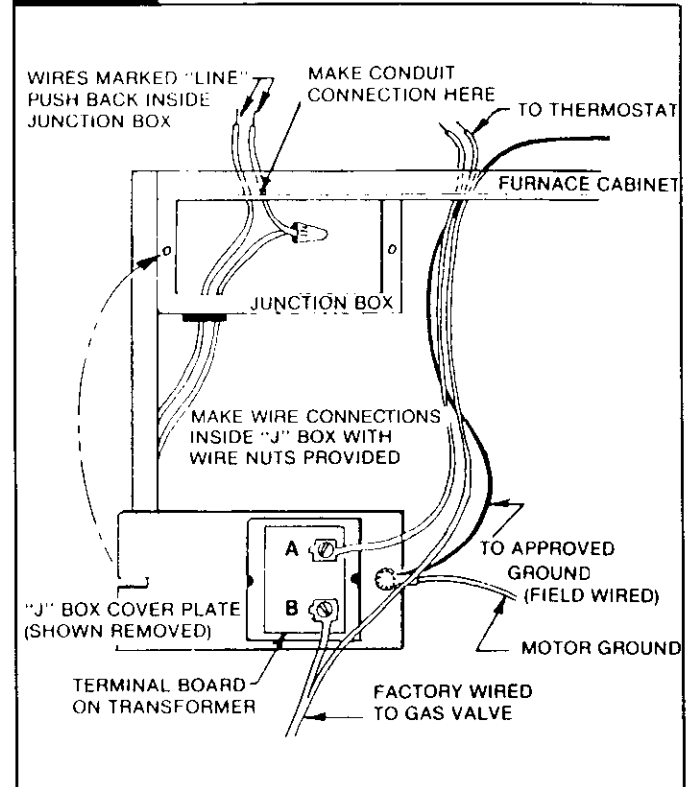

## LOW VOLTAGE CONNECTIONS

### CAUTION

The Heat Anticipator WILL BURNOUT if 24 volts are applied directly to thermostat by shorting out the gas valve or primary control during testing or by incorrect wiring.

## WALL THERMOSTAT WIRING

Run thermostat wire to the furnace.

Connect thermostat to two wires marked "Thermostat" extending from top of furnace, using two wire nuts provided. See Wiring Diagrams, pgs. 27 and 28. Refer to Fig. 15, pg. 11, also.

Replace fan to original position on motor shaft, tightening securely. Replace fan shroud, making sure it is centered vertically on the fan.

Tighten screws securely.

Replace top front panel and secure with thumbscrew.

COMPLETE WIRING DIAGRAMS ON PAGES 27 AND 28.

# Start-Up Procedure

Start the furnace using the procedures in section OPERATING YOUR FURNACE. Pages 19 thru 24.

## WARNING

DANGER OF PROPERTY DAMAGE,  
BODILY INJURY OR DEATH.

LIQUIFIED PETROLEUM L.P. GAS IS HEAVIER THAN AIR AND IT WILL SETTLE IN ANY LOW AREA, INCLUDING OPEN DEPRESSIONS AND IT WILL REMAIN THERE UNLESS AREA IS VENTILATED.

NEVER ATTEMPT STARTUP OF UNIT BEFORE THOROUGHLY VENTILATING AREA.

Check the furnace operation as outlined in the following instructions. If any sparking, odors or unusual noises are encountered, shut off electric power immediately. Recheck for wiring errors, or obstructions in or near fan motor.

## CHECK GAS INPUT AND PRESSURES

For furnace located at elevations between sea level and 2000 feet, the measured input must not be greater than the input shown on the rating plate of the furnace. For elevations above 2000 feet, the measured input must not exceed the input of the rating plate reduced by 4 percent for each 1000 feet that the furnace is above sea level.

Gas supply pressure and manifold pressure with the burners operating must also be as specified on the rating plate.

Type of Gas	Manifold Pressure, In. W.C.
Natural	4
L.P.	10.5

Rated input will be obtained on 2500 Btu propane at 10.5 inch manifold pressure with factory-sized orifices. If LP gas having a different heating value is supplied, orifices must be changed by a qualified service technician before the furnace is operated.

## CHECK THERMOSTAT

Check thermostat operation. When set above temperature shown on the thermostat, the main burner should light. Make certain the thermostat turns off the furnace when room temperature reaches the selected setting and starts the furnace when room temperature falls a few degrees. MAKE SURE THERMOSTAT ANTICIPATOR IS SET PROPERLY.

## ADJUST PILOT BURNER

### NOTE

#### STANDING PILOT MODELS ONLY

Pilot flame should surround 5/8 to 1/2 inch of the thermocouple tip. To adjust, remove cap from pilot adjusting screw on gas valve. Turn screw counterclockwise to increase flame, clockwise to decrease. Replace cap. See Figs. 31, Page 25 and Fig. 32, Page 26.

## CHECK THE MANIFOLD GAS PRESSURE

A tapped opening is provided in the gas valve to facilitate measuring the manifold gas pressure. A "U Tube" manometer having a scale range from 0 to 12 inches of water should be used for this measurement. The manifold pressure must be measured with the burner and pilot operating. Any major changes in flow must be made by changing the size of the burner orifice. Check with your local gas supplier for proper orifice sizing.

## CHECK THE GAS INPUT (NATURAL GAS ONLY)

### WARNING

NATURAL GAS HEATING VALUE (BTU PER CUBIC FOOT) CAN VARY SIGNIFICANTLY, THEREFORE, IT IS THE INSTALLER'S RESPONSIBILITY TO SEE THAT BTU INPUT TO THE FURNACE IS ADJUSTED PROPERLY. FAILURE TO DO SO COULD CAUSE HEAT EXCHANGER FAILURE, ASPHYXIATION, FIRE OR EXPLOSION, RESULTING IN DAMAGE, BODILY INJURY OR DEATH. REFER TO THE NATURAL FUEL GAS CODE (NFPA-54) TO BE SURE THE FURNACE IS BURNING FUEL AT THE PROPER RATE.

Underfiring could cause inadequate heat, excessive condensation or ignition problems. Overfiring could cause sooting flame impingement or overheating of heat exchanger.

Before starting natural gas input check, obtain heating value of gas (BTU per cubic foot) at standard conditions from your local supplier. This factor is used in "Check the Gas Input" section and procedure.

To measure the input using the gas meter, proceed as follows:

1. Turn off gas supply to all other appliances except the furnace.
2. With the furnace operating, time the smallest dial on the meter for one complete revolution. If this is a 2 cubic foot dial, divide the seconds by 2; if it is a 1 cubic foot dial, use the time in seconds as is. This gives the seconds per cubic foot of gas being delivered to the furnace.
3. Assuming natural gas with a heating value of 1000 BTU per cubic foot and 34 seconds per cubic foot as determined by step (2), then:  
$$\text{Input} = 1,000 \times 3,600 \div 34 = 106,000 \text{ BTU Per Hour}$$

This measured input must not be greater than the input indicated on the rating plate of the furnace.
4. Relight all other appliances turned off in step 1 above. Be sure all pilot burners are operating.

FIG. 27

THERMOSTAT (TYPICAL)

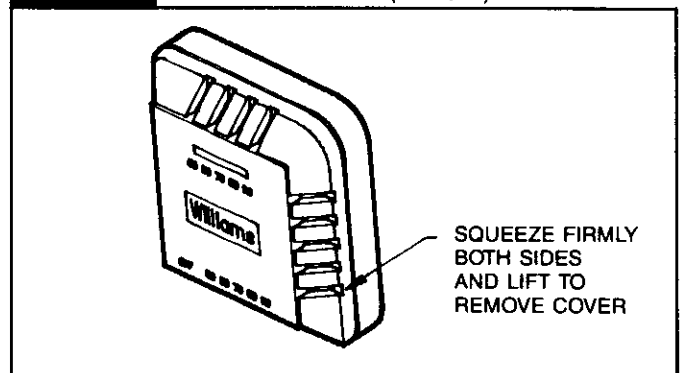

### WARNING

DANGER OF IGNITION FLASH AND EYE INJURY OR BLINDNESS  
PROTECT YOUR EYES. NEVER ATTEMPT TO LIGHT PILOT WITH GAS CONTROL VALVE KNOB IN "ON" POSITION. FLASH BACK COULD OCCUR.

# Operating Your Furnace

## STANDING PILOT MODELS\*

4007732, 6257732,  
4007731, 6257731.

### NOTE:

For models equipped with WILLIAMS gas valve P322041 or P322042 refer to this sheet and sheet 20 for "SAFETY & LIGHTING INSTRUCTION" and "TURN GAS OFF TO APPLIANCE."

For models equipped with WILLIAMS gas valve P321704 or P321705 refer to this sheet and sheet 21 for "SAFETY & LIGHTING INSTRUCTIONS" and "TURN GAS OFF TO APPLIANCE."

(All other models refer to sheet 22, 23 & 24.)

These furnaces are equipped with a manually operated Piezo spark igniter device to ignite the pilot gas. Follow the steps under "Lighting Instructions" (see Page 20 or Page 21) and use the manual spark ignitor to light the pilot in Step 10. Press spark ignitor button repeatedly.

On new installations, the gas lines will be filled with air and it may take several minutes to establish the pilot flame.

Keep all access doors and panels in place except for inspection and maintenance.

### WARNING

THE SURFACE OF THE FURNACE IS HOT DURING OPERATION. KEEP CHILDREN, CLOTHING, FURNITURE, AND FLAMMABLE MATERIAL AWAY FROM IT.

DO NOT STORE OR USE GASOLINE OR OTHER FLAMMABLE LIQUIDS OR VAPORS NEAR THE FURNACE.

### SAFETY LIMIT CONTROL

These furnaces are protected against unsafe operation by four automatic safety controls: (1) A safety pilot acts to shut OFF the gas valve in case of pilot failure; (2) A redundant gas valve; (3) A limit switch shuts down the main burner to prevent overheating the furnace cabinet; this limit switch will reset when furnace cools; and (4) A thermal overload protects the motor against burnout caused by current surges or if anything should block the flow of air through the furnace. This switch will reset itself when the motor cools down and it cannot be adjusted.

### WARNING

DANGER OF BODILY INJURY OR DEATH.  
DO NOT OPERATE THE FURNACE WITH A BROKEN OR MISSING PILOT OBSERVATION DOOR.

For models equipped with WILLIAMS gas valve P321704 or P321705.

Models are equipped with a two-rate control valve. The rate knob on the gas valve is marked "LO" and "HI." Turn the rate knob to the "LO" position and the room thermostat will operate the main burner at about 70% of maximum capacity. Turn the rate knob to the "HI" position only when a fast heat-up is desired during extremely cold weather. High operation develops maximum capacity of the furnace.

A two-speed fan is used with Models 6257732, and 6257731.

Blower will operate at low speed then shift to high speed as the furnace heats up.

### WARNING

DANGER OF PROPERTY DAMAGE  
BODILY INJURY OR DEATH.  
IF THE FURNACE OVERHEATS OR FAILS TO SHUT OFF, CLOSE MANUAL GAS VALVE FOR THE FURNACE BEFORE TURNING OFF ELECTRIC POWER.

## FOR YOUR SAFETY, READ BEFORE LIGHTING

**WARNING: If you do not follow these instructions exactly, a fire or explosion may result causing property damage, personal injury or loss of life.**

- A. This appliance has a pilot which must be lighted by hand. When lighting the pilot, follow these instructions exactly.
- B. **BEFORE LIGHTING** smell around the appliance area for gas. Be sure to smell next to the floor because some gas is heavier than air and will settle on the floor.

### WHAT TO DO IF YOU SMELL GAS

- Do not try to light any appliance or strike a match.
- Do not touch any electric switch; do not use any phone in your building.
- Immediately call your gas supplier from a neighbor's phone. Follow the gas supplier's instructions.

- If you cannot reach your gas supplier, call the fire department.

- C. Use only your hand to push in or turn the gas control knob. Never use tools. If the knob will not push in or turn by hand, don't try to repair it, call a qualified service technician. Force or attempted repair may result in a fire or explosion.

- D. Do not use this appliance if any part has been under water. Immediately call a qualified service technician to inspect the appliance and to replace any part of the control system and any gas control which has been under water.

## LIGHTING INSTRUCTIONS

1. **STOP!** Read the safety information above.
2. Set the thermostat to lowest setting.
3. Turn off all electric power to the appliance.
4. Remove control access panel.
5. Turn gas control knob clockwise  to "OFF".

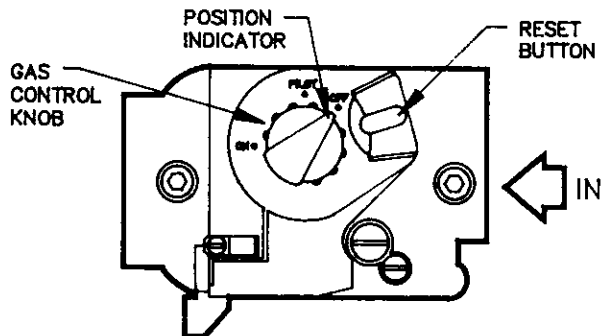

6. Wait five (5) minutes to clear out any gas then smell for gas, including near the floor. If you then smell gas, stop! Follow "B" in the safety information above. If you don't smell gas, go to next step.
7. Loosen wingnut and open pilot observation door (if equipped).

8. Find pilot—follow metal tube from gas control. The pilot is mounted on side of burner.
9. Turn knob on gas control counterclockwise  to "PILOT."

10. Push in red reset button all the way and hold in. Immediately light the pilot. Continue to hold the red reset button in for about (1) minute after the pilot is lit. Release button and it will pop back up. Pilot should remain lit. If it goes out, repeat steps 5 through 10.

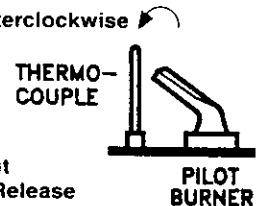

- If button does not pop up when released, stop and immediately call your service technician or gas supplier.
  - If the pilot will not stay lit after several tries, turn the gas control knob to "OFF" and call your service technician or gas supplier.
11. Close pilot observation door, tighten wingnut (if equipped).
  12. Turn gas control knob counterclockwise  to "ON". Knob can be turned to "ON" only if red reset button is up.
  13. Replace control access panel.
  14. Turn on all electric power to the appliance.
  15. Set thermostat to desired setting.

## TO TURN OFF GAS TO APPLIANCE

1. Set the thermostat to lowest setting.
2. Turn off all electric power to the appliance if service is to be performed.
3. Remove control access panel.
4. Push in gas control knob slightly and turn clockwise  to "OFF". Do not Force.
5. Replace control access panel.

**WARNING: DUE TO HIGH SURFACE TEMPERATURES — KEEP CHILDREN, CLOTHING, FURNITURE OR ANY COMBUSTIBLE MATERIAL AWAY FROM FURNACE.**  
**IMPORTANT: KEEP BURNER AND CONTROL COMPARTMENT CLEAN.**

## FOR YOUR SAFETY, READ BEFORE LIGHTING

**WARNING: If you do not follow these instructions exactly, a fire or explosion may result causing property damage, personal injury or loss of life.**

- A. This appliance has a pilot which must be lighted by hand. When lighting the pilot, follow these instructions exactly.
- B. **BEFORE LIGHTING** smell around the appliance area for gas. Be sure to smell next to the floor because some gas is heavier than air and will settle on the floor.

### WHAT TO DO IF YOU SMELL GAS

- Do not try to light any appliance or strike a match.
- Do not touch any electric switch; do not use any phone in your building.
- Immediately call your gas supplier from a neighbor's phone. Follow the gas supplier's instructions.

- If you cannot reach your gas supplier, call the fire department.

- C. Use only your hand to push in or move the selector arm. Never use tools. If the arm will not push in or move by hand, don't try to repair it, call a qualified service technician. Force or attempted repair may result in a fire or explosion.
- D. Do not use this appliance if any part has been under water. Immediately call a qualified service technician to inspect the appliance and to replace any part of the control system and any gas control which has been under water.

## LIGHTING INSTRUCTIONS

1. **STOP!** Read the safety information above.
2. Set the thermostat to lowest setting.
3. Turn off all electric power to the appliance.
4. Remove control access panel.
5. From "ON" position, depress and move selector arm on gas control to "OFF" position. Do not force.

GAS CONTROL  
SELECTOR  
ARM SHOWN  
IN "OFF"  
POSITION

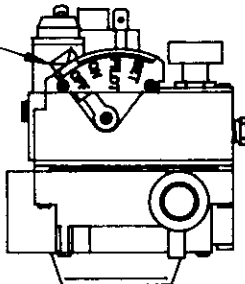

6. Wait five minutes to clear out any gas then smell for gas, including near the floor. If you then smell gas, stop! Follow "B" in the safety information above. If you don't smell gas, go to next step.
7. Loosen wingnut and open pilot observation door (if equipped).

8. Find pilot—follow metal tube from gas control. The pilot is mounted on side of burner.
9. Hold lighted match at pilot burner.

10. Move selector arm to "SET" position and light pilot. Hold in "SET" position for 1/2 minute after pilot is lit.

NOTE: Sufficient time must be allowed for pilot flame to heat thermocouple and hold safety magnet in locked-up position. Also, time must be allowed for air to be purged from gas lines during first starting operation.

11. Release selector arm, and if pilot remains lit, move selector arm to "ON" position.
  - If the pilot will not stay lit after several tries, move the selector arm to "OFF" and call your service technician or gas supplier.
12. Close pilot observation door and tighten wingnut (if equipped).
13. Replace control access panel.
14. Turn on all electric power to the appliance.
15. Set thermostat to desired setting.

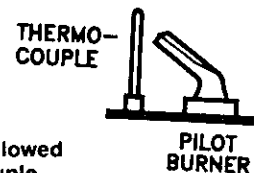

## TO TURN OFF GAS TO APPLIANCE

1. Set the thermostat to lowest setting.
2. Turn off all electric power to the appliance if service is to be performed.
3. Remove control access panel.
4. From "ON" position, depress and move selector arm on gas control to "OFF" position. Do not force.
5. Replace control access panel.

**WARNING: DUE TO HIGH SURFACE TEMPERATURES — KEEP CHILDREN, CLOTHING, FURNITURE OR ANY COMBUSTIBLE MATERIAL AWAY FROM FURNACE.  
IMPORTANT: KEEP BURNER AND CONTROL COMPARTMENT CLEAN.**

# Operating Your Furnace

## ELECTRONIC IGNITION MODELS\*

4007332, 5507332,  
4007331, 5507331.

### NOTE:

For models equipped with WILLIAMS gas valve P322043 or P322044 refer to this sheet and sheet 23 for "SAFETY & LIGHTING INSTRUCTION" and "TURN GAS OFF TO APPLIANCE."

For models equipped with WILLIAMS gas valve P321897 or P321898 refer to this sheet and sheet 24 for "SAFETY & LIGHTING INSTRUCTIONS" and "TURN GAS OFF TO APPLIANCE."

(All other models refer to sheet 19, 20 & 21.)

### THE FURNACE WORKS LIKE THIS:

1. Thermostat turns on the control module.
2. Automatic relight system (in module) opens gas valve and electronically ignites pilot. After pilot flame has been established and proven by the control module, main gas valve circuit opens and pilot lights main burners.
3. Heat builds up in the furnace and starts the fan. The heated air comes out the front bottom louvered panel at floor level.
4. When the thermostat setting is reached, it shuts off the main burner.
5. The fan runs until the heat is removed from furnace, then it turns off.

### SAFETY LIMIT CONTROL

These furnaces are protected against unsafe operation by three automatic safety controls: (1) The electronic ignition system; (2) A limit switch shuts down the main burner to prevent overheating the furnace cabinet; this limit switch will reset when furnace cools; (3) A thermal overload protects the motor against burnout caused by current surges or if anything should block the flow of air through the furnace, the switch will turn the main burner off. When motor cools down, this switch will reset itself. This switch cannot be adjusted.

### WARNING

THE SURFACE OF THE FURNACE IS HOT DURING OPERATION. KEEP CHILDREN, CLOTHING, FURNITURE, AND FLAMMABLE MATERIAL AWAY FROM IT.

DO NOT STORE OR USE GASOLINE OR OTHER FLAMMABLE LIQUIDS OR VAPORS NEAR THE FURNACE.

### WARNING

DANGER OF BODILY INJURY OR DEATH.  
DO NOT OPERATE THE FURNACE WITH A BROKEN OR MISSING PILOT OBSERVATION DOOR.

For models equipped with WILLIAMS gas valve P321897 or P321898.

Models are equipped with a two-rate control valve. The rate knob on the gas valve is marked "LO" and "HI." Turn the rate knob to the "LO" position and the room thermostat will operate the main burner at about 70% of maximum capacity. Turn the rate knob to the "HI" position only when a fast heat-up is desired during extremely cold weather. High operation develops maximum capacity of the furnace.

A two-speed fan is used with Models 5507332, and 5507331.

Blower will operate at low speed then shift to high speed as the furnace heats up.

### WARNING

DANGER OF PROPERTY DAMAGE  
BODILY INJURY OR DEATH.  
IF THE FURNACE OVERHEATS OR FAILS TO SHUT OFF, CLOSE MANUAL GAS VALVE FOR THE FURNACE BEFORE TURNING OFF ELECTRIC POWER.

## FOR YOUR SAFETY, READ BEFORE LIGHTING

**WARNING: If you do not follow these instructions exactly, a fire or explosion may result causing property damage, personal injury or loss of life.**

- A. This appliance is equipped with an ignition device which automatically lights the pilot. Do not try to light the pilot by hand.
- B. BEFORE LIGHTING smell around the appliance area for gas. Be sure to smell next to the floor because some gas is heavier than air and will settle on the floor.

### WHAT TO DO IF YOU SMELL GAS

- Do not try to light any appliance or strike a match.
- Do not touch any electric switch; do not use any phone in your building.
- Immediately call your gas supplier from a neighbor's phone. Follow the gas supplier's instructions.

- If you cannot reach your gas supplier, call the fire department.
- C. Use only your hand to push in or turn the gas control knob. Never use tools. If the knob will not push in or turn by hand, don't try to repair it, call a qualified service technician. Force or attempted repair may result in a fire or explosion.
- D. Do not use this appliance if any part has been under water. Immediately call a qualified service technician to inspect the appliance and to replace any part of the control system and any gas control which has been under water.

## LIGHTING INSTRUCTIONS

1. STOP! Read the safety information above.
2. Set the thermostat to lowest setting.
3. Turn off all electric power to the appliance.
4. This appliance is equipped with an ignition device which automatically lights the pilot. Do not try to light the pilot by hand.
5. Remove control access panel.
6. Turn gas control knob clockwise  to "OFF".

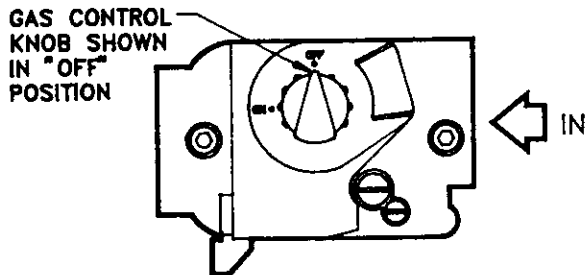

7. Wait five (5) minutes to clear out any gas then smell for gas, including near the floor. If you then smell gas, stop! Follow "B" in the safety information above. If you don't smell gas, go to next step.

8. Turn the gas control knob counterclockwise  to "ON".
  9. Replace control access panel.
  10. Turn on all electric power to the appliance.
  11. Turn thermostat to on (HEAT) position. Set thermostat higher than room temperature. Pilot will automatically light and main burner(s) will light in approximately 45 seconds.
- NOTE: On initial start-up or after prolonged shut down, several ignition cycles may be required to purge gas lines. To accomplish the recycle - repeat steps 5 through 11 until pilot is established.
12. Set thermostat to desired setting.
  13. After the room thermostat turns the system off, a delay of approximately one minute is required before the system can be turned on again.
  14. If the appliance will not operate, follow the instructions "To Turn Off Gas To Appliance" and call your service technician or gas supplier.

## TO TURN OFF GAS TO APPLIANCE

1. Set the thermostat to lowest setting.
2. Turn off all electric power to the appliance if service is to be performed.
3. Remove control access panel.
4. Push in gas control knob slightly and turn clockwise  to "OFF". Do not Force.
5. Replace control access panel.

**WARNING: DUE TO HIGH SURFACE TEMPERATURES — KEEP CHILDREN, CLOTHING, FURNITURE OR ANY COMBUSTIBLE MATERIAL AWAY FROM FURNACE.**  
**IMPORTANT: KEEP BURNER AND CONTROL COMPARTMENT CLEAN.**

## FOR YOUR SAFETY, READ BEFORE LIGHTING

**WARNING: If you do not follow these instructions exactly, a fire or explosion may result causing property damage, personal injury or loss of life.**

- A. This appliance is equipped with an ignition device which automatically lights the pilot. Do not try to light the pilot by hand.
- B. **BEFORE LIGHTING** smell around the appliance area for gas. Be sure to smell next to the floor because some gas is heavier than air and will settle on the floor.
- WHAT TO DO IF YOU SMELL GAS**
- Do not try to light any appliance or strike a match.
  - Do not touch any electric switch; do not use any phone in your building.
  - Immediately call your gas supplier from a neighbor's phone. Follow the gas supplier's instructions.
- If you cannot reach your gas supplier, call the fire department.
- C. Use only your hand to push in or move the selector arm. Never use tools. If the arm will not push in or move by hand, don't try to repair it, call a qualified service technician. Force or attempted repair may result in a fire or explosion.
- D. Do not use this appliance if any part has been under water. Immediately call a qualified service technician to inspect the appliance and to replace any part of the control system and any gas control which has been under water.

## LIGHTING INSTRUCTIONS

1. STOP! Read the safety information above.
  2. Set the thermostat to lowest setting.
  3. Turn off all electric power to the appliance.
  4. This appliance is equipped with an ignition device which automatically lights the pilot. Do not try to light the pilot by hand.
  5. Remove control access panel.
  6. From "ON" position, depress and move selector arm on gas control to "OFF" position. Do not force.
  7. Wait five (5) minutes to clear out any gas then smell for gas, including near the floor. If you then smell gas, stop! Follow "B" in the safety information above. If you don't smell gas, go to next step.
  8. Move selector arm to "ON" position.
  9. Replace control access panel.
  10. Turn on all electric power to the appliance.
  11. Turn thermostat to on (HEAT) position. Set thermostat higher than room temperature. Set thermostat higher than room temperature. Pilot will automatically light and main burner(s) will light in approximately 45 seconds.
  12. Set thermostat to desired setting.
  13. After the room thermostat turns the system off, a delay of approximately one minute is required before the system can be turned on again.
  14. If the appliance will not operate, follow the instructions "To Turn Off Gas To Appliance" and call your service technician or gas supplier.
- NOTE: On initial start-up or after prolonged shut down, several ignition cycles may be required to purge gas lines. To accomplish the recycle - repeat steps 6 through 11 until pilot is established.

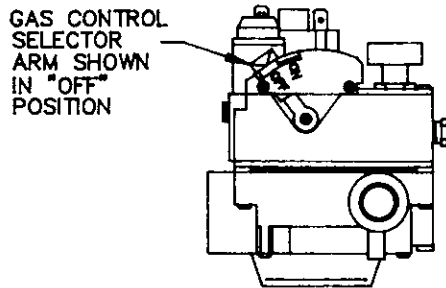

## TO TURN OFF GAS TO APPLIANCE

1. Set the thermostat to lowest setting.
2. Turn off all electric power to the appliance if service is to be performed.
3. Remove control access panel.
4. From "ON" position, depress and move selector arm on gas control to "OFF" position. Do not force.
5. Replace control access panel.

**WARNING: DUE TO HIGH SURFACE TEMPERATURES — KEEP CHILDREN, CLOTHING, FURNITURE OR ANY COMBUSTIBLE MATERIAL AWAY FROM FURNACE.**  
**IMPORTANT: KEEP BURNER AND CONTROL COMPARTMENT CLEAN.**



# How To Care For Your Furnace

## WARNING

DANGER OF BODILY INJURY OR DEATH  
TURN OFF ELECTRIC POWER SUPPLY AT DISCONNECT SWITCH, FUSE BOX OR SERVICE PANEL BEFORE REMOVING ANY DOORS OR ACCESS OR SERVICE PANELS FROM UNIT.

## CABINET FINISH

Clean cabinet with damp rag. Never use abrasive cleaners. Cabinets are finished in heat resistant baked enamel - DO NOT refinish with wall paint.

## COMBUSTION AND VENTILATION AIR

The combustion and ventilation air supply must not be blocked.

Do not put anything in or on the furnace cabinet.

For better circulation and more effective heating, do not place obstructive furniture closer than four feet to the front of the cabinet or two feet to the side of the cabinet.

## FURNACE AREA

Keep the area near the furnace clear and free from combustible materials, gasoline, and other flammable liquids and vapors.

## ANNUAL UPKEEP NEEDED

It is recommended that a qualified service technician perform these checks at the beginning of each heating season.

## CLEANING AND OILING

Shut off electricity, then remove cabinet door and front panel. Clean any lint or dirt from fan blades, fan motor, and exposed air passages. Use a brush. Put 5 drops of SAE 20 oil in each of the two cups or oil tubes on the fan motor, See Fig. 30, below.

FIG. 30

MOTOR OIL HOLES

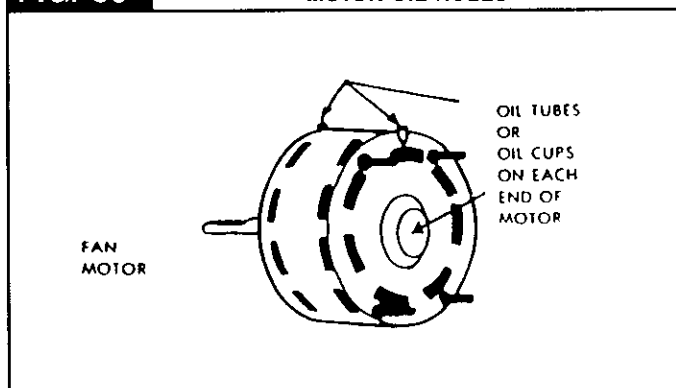

## PILOT BURNER

Light pilot using instructions in OPERATING YOUR FURNACE (on Pages 19 thru 24, depending on your model).

Pilot flame should surround 5/8 to 1/2 inch of the thermocouple tip. Refer to Fig. 32, Page 26. If flame needs adjusting, do it as follows:

## ADJUST PILOT BURNER

See Fig. 31 and 32. (Page 26)

1. Remove screw cover over pilot adjusting screw.
2. Insert small screwdriver, Adjust flame as needed. Turn screw counterclockwise ( ↺ ) to increase flame, clockwise ( ↻ ) to decrease.
3. Turn thermostat to highest setting. Main burners should light quickly and smoothly. Turn thermostat to lowest setting. Main burners should go out. Pilot should remain lit except for electronic ignition models.
4. Replace screw cover over pilot adjusting screw.

## BURNER FLAME

Start the furnace and let it operate about 10 minutes then look at the burner flame. Flames should be soft and blue, see Fig. 31. If flames appear abnormal, contact the gas company or a qualified service technician immediately.

## VENTING SYSTEM

Make sure that no parts of the vent air system are blocked, rusted or damaged (including joint gaskets). Clean or replace before using furnace. See Page 12 and 13 for proper assembly and resealing of vent-air system.

FIG. 31

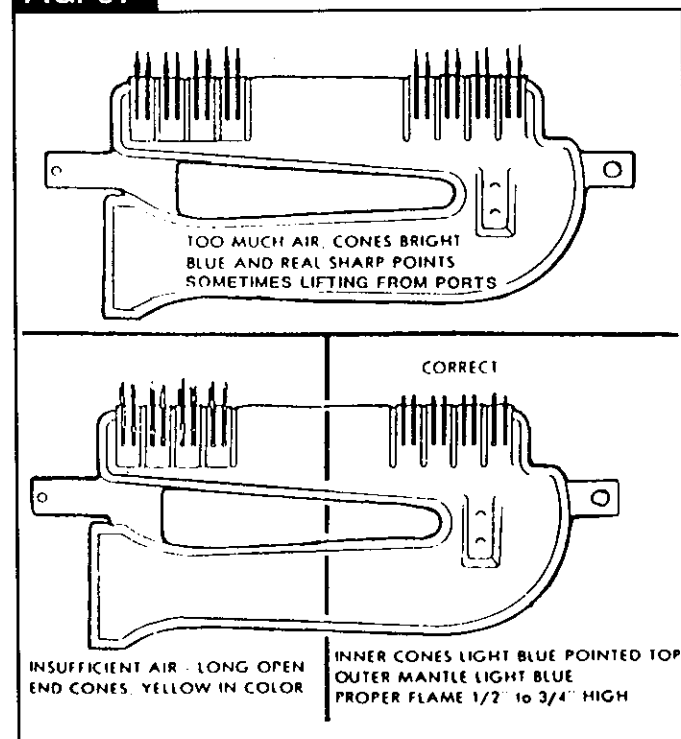

# How To Care For Your Furnace (Con't)

## BURNER CLEANING

Check burner. If cleaning is required, contact a qualified service technician to clean and service burner.

### WARNING

**DANGER OF BODILY INJURY OR DEATH**  
**MAKE SURE ELECTRIC POWER AND GAS SUPPLY ARE OFF BEFORE REMOVING PANELS OR DOORS, ETC.**

Disconnect Gas line inside cabinet.

Remove three screws from the front of the combustion chamber bottom panel and drop assembly down. Clean inside the combustion chamber and the burner with a shop type vacuum cleaner.

To remove burners remove screw from end of burner and slide burner out of bracket (may be necessary to slightly spring bracket).

Inspect the Burner Box gasket. Replace if damaged.

Replace burner assembly and control assembly by reversing the above procedures.

**FIG. 32**

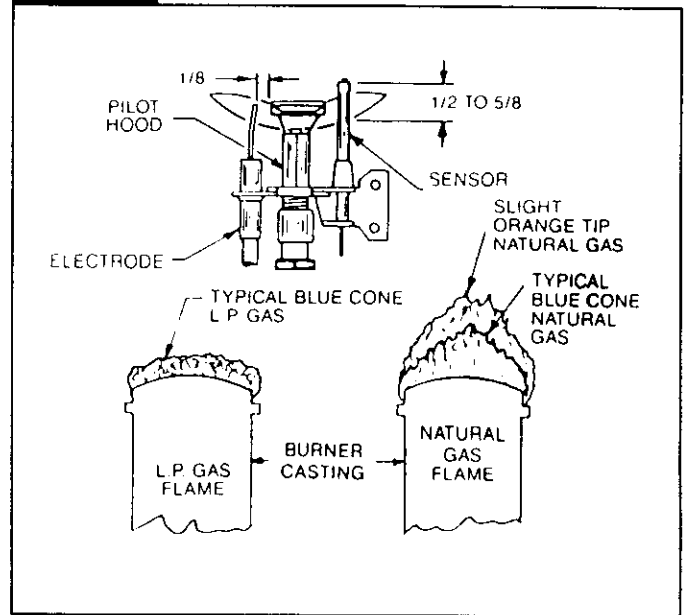

## Furnace Technical Information

MODEL NUMBER	TYPE GAS	**RATING IN BTUH		MAIN BURNER ORIFICE		
		INPUT	HTG. CAPAC.	DRILL	DEC.	QTY.
4007332	NAT	40,000	32,000	#34	.1110	1
4007331	L.P.	40,000	32,000	#50	.0700	1
4007732	NAT	40,000	32,000	#34	.1110	1
4007731	L.P.	40,000	32,000	#50	.0700	1
5507332	NAT	55,000	44,000	#42	.0935	2
5507331	L.P.	55,000	44,000	#54	.0550	2
6257732	NAT	62,500	50,000	#39	.0995	2
6257731	L.P.	62,500	50,000	#53	.0595	2

\*\*For elevations above 2000 feet reduce ratings 4% for each 1000 feet above sea level.

\*\*\*Btuh = British Thermal Units per hour

The efficiency rating of these appliances is a product thermal efficiency rating determined under continuous operating conditions and was determined independently of any installed system.

# WIRING DIAGRAMS FOR MODELS

4007732 and 4007731

6257732 and 6257731

**FOR 40M B.T.U.  
FAN TYPE DIRECT VENT WALL FURNACE  
WITH CONTINUOUS PILOT CONTROL SYSTEM**

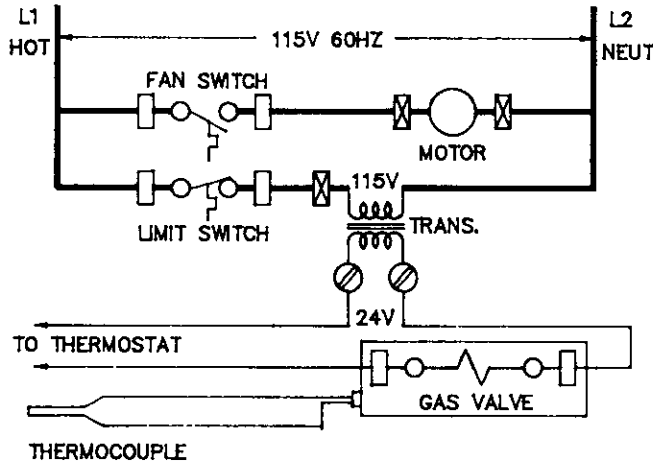

**LEGEND**

- FACTORY WIRED LINE VOLTAGE.
- FACTORY WIRED LOW VOLTAGE.
- 1/4 QUICK CONNECT TERMINAL FOR FACTORY WIRING.
- ⊗ WIRE CONNECTOR FOR FACTORY WIRING LINE VOLTAGE.
- ⊙ SCREW TERMINAL LOW VOLTAGE.

**NOTE:**

1. If any of the original wire as supplied with the appliance has to be replaced, use only 18 Ga., 4/64 insulation, 105° C. AWM copper wire or its equivalent 115V - 60Hz. - less than 3 amps.
2. MOTOR IS THERMALLY OVERLOAD PROTECTED. 115V. 60Hz - LESS THAN 3 AMPS.

**FOR 62.5M B.T.U.  
FAN TYPE DIRECT VENT WALL FURNACE  
WITH CONTINUOUS PILOT CONTROL SYSTEM**

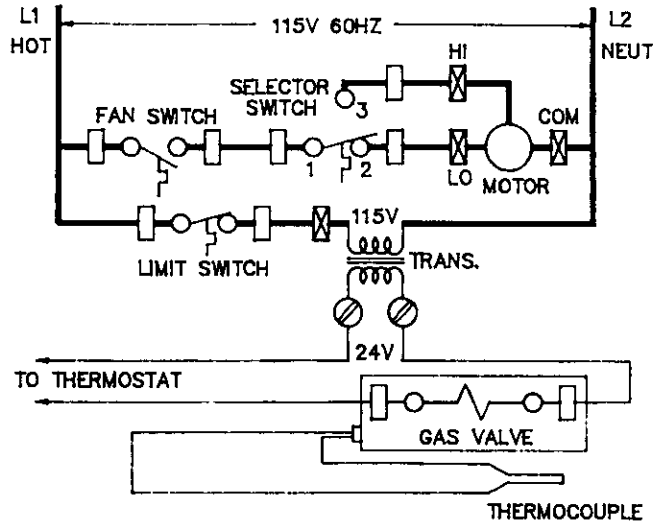

**LEGEND**

- FACTORY WIRED LINE VOLTAGE.
- FACTORY WIRED LOW VOLTAGE.
- 1/4 QUICK CONNECT TERMINAL FOR FACTORY WIRING.
- ⊗ WIRE CONNECTOR FOR FACTORY WIRING LINE VOLTAGE.
- ⊙ SCREW TERMINAL LOW VOLTAGE.

**NOTE:**

1. If any of the original wire as supplied with the appliance has to be replaced, use only 18 Ga., 4/64 insulation, 105° C. AWM copper wire or its equivalent 115V - 60Hz. - less than 3 amps.
2. MOTOR IS THERMALLY OVERLOAD PROTECTED. 115V. 60Hz - LESS THAN 3 AMPS.

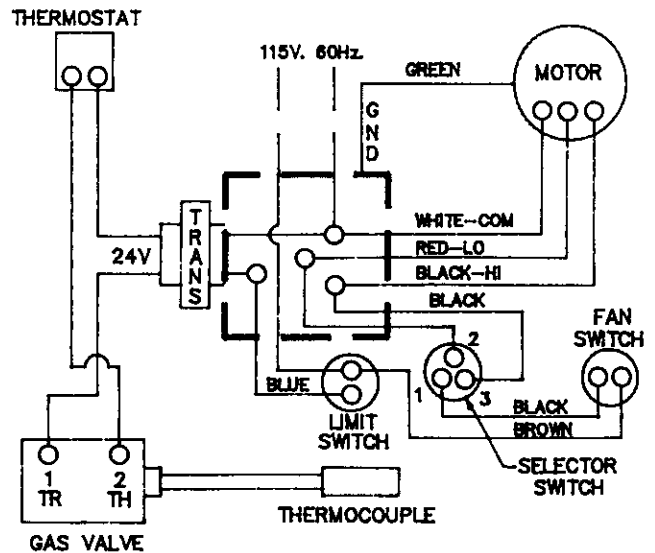
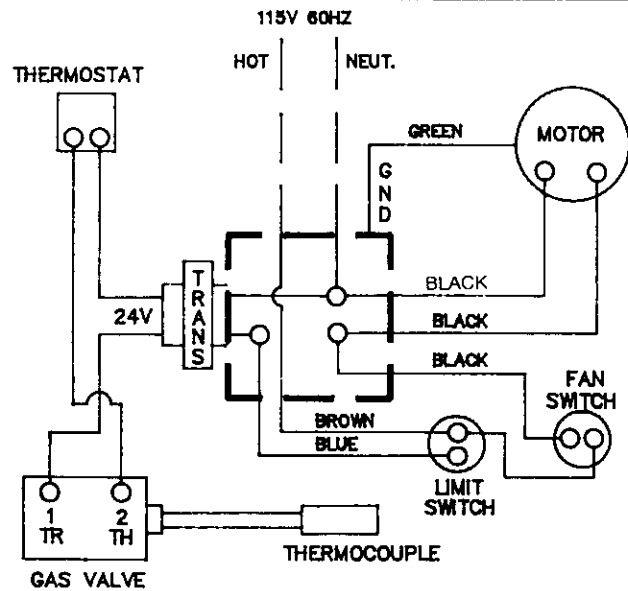

# WIRING DIAGRAMS FOR MODELS

4007332 and 4007331

5507332 and 5507331

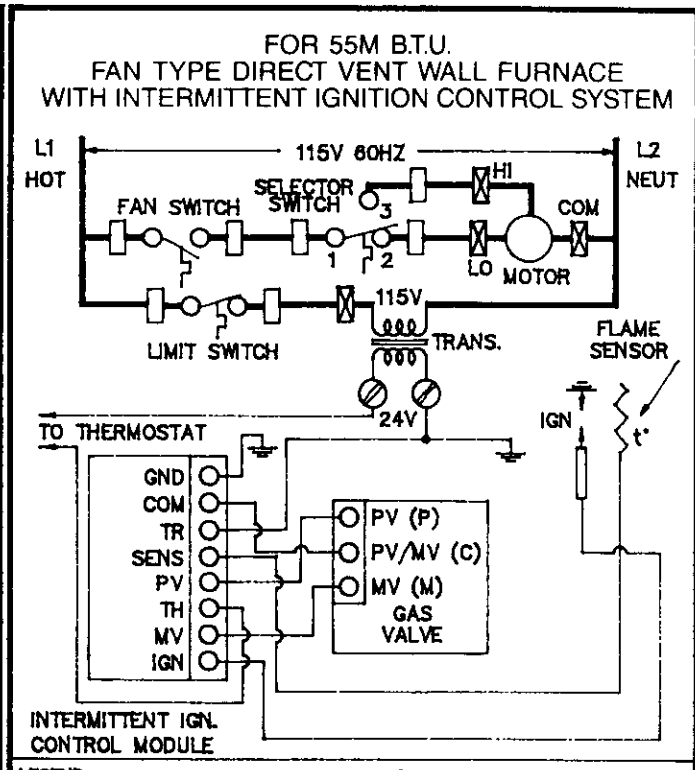
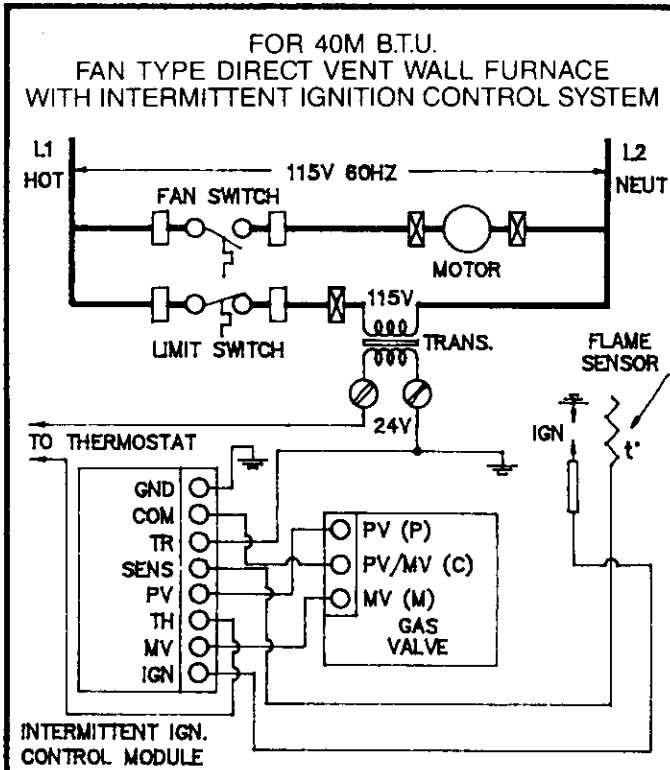

**LEGEND**

- FACTORY WIRED LINE VOLTAGE.
- FACTORY WIRED LOW VOLTAGE.
- 1/4 QUICK CONNECT TERMINAL FOR FACTORY WIRING.
- WIRE CONNECTOR FOR FACTORY WIRING LINE VOLTAGE.
- SCREW TERMINAL LOW VOLTAGE.

**NOTE:**

1. If any of the original wire as supplied with the appliance has to be replaced, use only 18 Ga., 4/64 insulation, 105° C. AWM copper wire or its equivalent 115V - 60Hz. - less than 3 amps.
2. MOTOR IS THERMALLY OVERLOAD PROTECTED. 115V. 60Hz - LESS THAN 3 AMPS.

**LEGEND**

- FACTORY WIRED LINE VOLTAGE.
- FACTORY WIRED LOW VOLTAGE.
- 1/4 QUICK CONNECT TERMINAL FOR FACTORY WIRING.
- WIRE CONNECTOR FOR FACTORY WIRING LINE VOLTAGE.
- SCREW TERMINAL LOW VOLTAGE.

**NOTE:**

1. If any of the original wire as supplied with the appliance has to be replaced, use only 18 Ga., 4/64 insulation, 105° C. AWM copper wire or its equivalent 115V - 60Hz. - less than 3 amps.
2. MOTOR IS THERMALLY OVERLOAD PROTECTED. 115V. 60Hz - LESS THAN 3 AMPS.

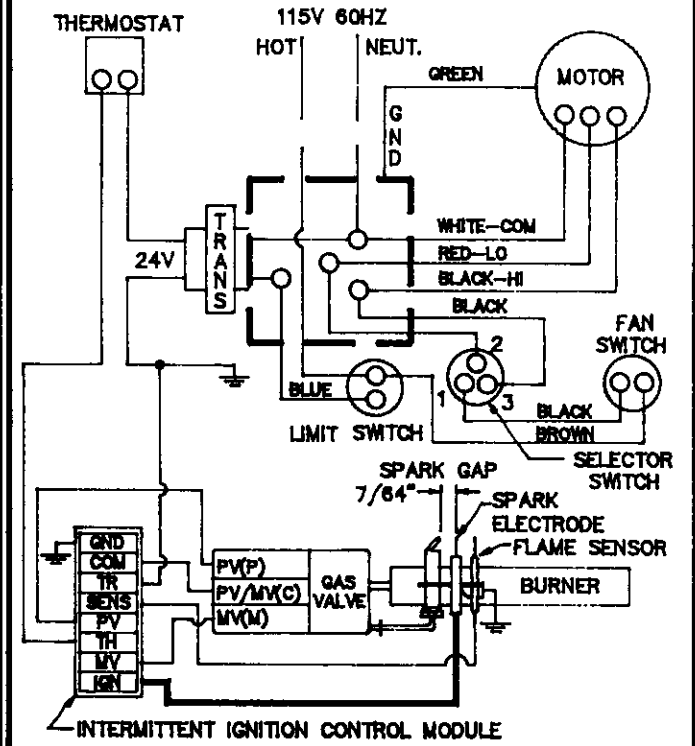
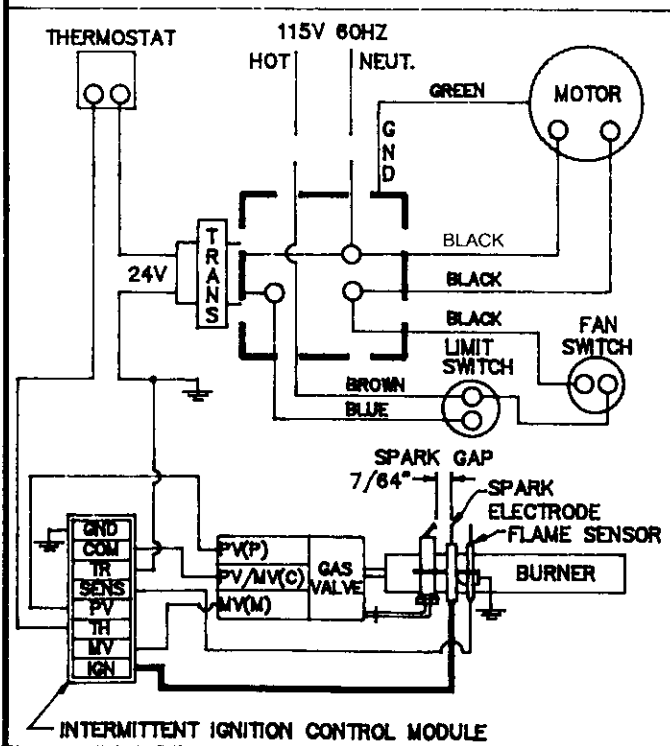

**Troubleshooting Chart for Models  
4007732, 6257732, 4007731 and 6257731**

SYMPTOM	POSSIBLE CAUSE(S)	CORRECTIVE ACTION
<p>1. Pilot will not stay lit after following lighting instructions.</p>	<p>a. Thermocouple producing insufficient millivoltage.</p> <p>b. Loose or dirty thermocouple connection at gas valve.</p> <p>c. Thermocouple defective.</p> <p>d. Thermomagnet pilot safety defective.</p>	<p>a. Check pilot flame — must impinge on thermocouple. Pilot flame may be low or blowing (high) causing safety to drop out. Pilot orifice or aerating hole may be plugged (check for spiders, webs or other organic material). Be sure the thermocouple is fully inserted in bracket.</p> <p>b. Clean and/or tighten thermocouple fitting at connection to valve.</p> <p>c. Check thermocouple with millivolt meter — should generate approximately 30 millivolts when not connected to load. When connected to load, should generate approximately 14 millivolts. if below 7 millivolts, replace.</p> <p>e. Replace gas valve after above is checked out.</p>
<p>2. Main burner will not come ON — pilot burning and thermostat set for heat.</p>	<p>a. Gas valve turned OFF.</p>	<p>a. Turn gas valve knob to "ON" position — if no main gas flow, proceed to Step. "b".</p>

- Continued Next Page -

**Troubleshooting Chart for Models  
4007732, 6257732, 4007731 and 6257731 (Continued)**

SYMPTOM	POSSIBLE CAUSE(S)	CORRECTIVE ACTION
<p>2. Main burner will not come on — pilot burning and thermostat set for heat (continued).</p>	<p>b. Electric power to furnace turned OFF.</p> <p>c. Low voltage transformer or limit switch defective.</p> <p>d. Wall thermostat defective.</p> <p>e. Burner orifice plugged.</p> <p>f. Gas valve defective.</p>	<p>b. Check for line voltage at furnace — if okay and no main gas flow, proceed to Step "c".</p> <p>c. Check for 24 volts at the low voltage terminals of the transformer. If no voltage, turn OFF electric power to furnace. Remove one wire from limit switch and check for continuity across both terminals. No continuity — replace limit switch. With a good limit switch back in the circuit and the electric power turned ON — if no voltage, replace transformer. NOTE: Before replacing the transformer or limit switch, check wiring for loose connections or broken wires and repair as needed. If voltage is present at transformer, proceed to Step "d".</p> <p>d. With thermostat set for heat (contacts closed), check for voltage at terminals on gas valve. If no voltage is present, replace defective thermostat. NOTE: Before replacing thermostat, be sure to check wiring from furnace to thermostat for loose connections or broken wires and replace as needed. If voltage is present at terminals on gas valve and still no gas flow to main burners, proceed to Step "e".</p> <p>e. Clean or replace orifice — if okay and still no gas flow to main burners, proceed to Step "f".</p> <p>f. Replace defective gas valve.</p>
<p>3. Burner comes ON, but goes OFF before blower turns ON.*</p>	<p>a. Defective wiring.</p> <p>b. Defective switch.</p> <p>c. Defective motor (2-speed)</p> <p>d. Defective motor (1-speed).</p>	<p>a. Turn off electric power to furnace. Remove top front panel, fan shroud and blower wheel. Refer to wiring diagram and check all wiring inside junction box. Remove center front panel and check all wiring inside switch box containing fan, limit and selector switches. Correct if necessary. If correct, proceed to Step "b". NOTE: Selector switch used only on Models — 5507331, 5507332, 6257731, 6257732.</p> <p>a. If burner goes OFF in less than five minutes from room temperature start, check limit control switch. If defective — replace. NOTE: Blower should turn ON within 3 minutes after burner is ON from a room temperature start. If not, proceed to Step "c".</p> <p>c. Jumper across fan switch, turn electric power ON, motor should rotate. A 2-speed motor is used — jumper from "brown" terminal on fan switch to #2 (red) terminal on selector switch, motor should rotate on "LOW" speed. Jumper from same "brown" terminal on fan switch to #3 (black) terminal on selector switch, motor should rotate on "HIGH" speed. Replace motor if defective.</p> <p>d. Jumper across fan switch, turn electric power ON, motor should rotate. Replace motor if defective.</p>

\*Also applicable to Models 4007332, 5507332, 4007331 and 5507331.

- Continued Next Page -

**Troubleshooting Chart for Models  
4007732, 6257732, 4007731 and 6257731 (Continued)**

SYMPTOM	POSSIBLE CAUSE(S)	CORRECTIVE ACTION
3. Burner comes ON, but goes OFF before blower turns ON (continued).	e. Defective fan switch.	e. If, after checking above possibilities, problem still exists, replace fan switch.
4. Burner comes ON, blower comes ON, but cycles ON and OFF while burner remains ON.*	Furnace not operating at full rate.	Check for low gas pressure at gas valve — should be 4" W.C. for natural gas, 11" W.C. for L.P.G. Check burner orifice.
5. Burner comes ON, blower comes ON, but burner cycles OFF and ON with blower ON.*	a. Furnace operating over-rate. b. Line voltage too low. c. Recirculation.	a. Check for high gas pressure at gas valve — correct if necessary. See correct pressure above. b. Check line voltage to motor; if below 115 volts, motor will run too slow. c. Heated air discharging against an object causing recirculation, such as a hall installation or a large piece of furniture within 4' of discharge.
6. Furnace operates but turns OFF before room temperature is attained.*	a. Thermostat location. b. Defective thermostat.	a. Check location of thermostat. It should not be in the path of warm air discharge from furnace, near a lamp, or above a TV set or stereo. b. Check thermostat calibration or replace.
7. Furnace operates but will not shut OFF when room temperature is attained.*	a. Thermostat wiring defective. b. Thermostat location. c. Improper thermostat anticipator setting.	a. Check thermostat wiring from furnace to thermostat (may be shorted together by a nail, or staple). b. Check thermostat location — if an outside wall or a hole in wall behind thermostat causing cold air to contact thermostat — relocate. c. Set anticipator per THERMOSTAT INSTALLATION, page 11.
8. Abnormal noises* during operation.	a. Blower noise. b. Expansion noise ticking. c. Selector switch defective. (2-speed motor)	a. Check motor mounts — they may be loose. Blower wheel could be out of balance. Setscrew may be loose on motor shaft. Blower may be rubbing on fan shroud. Motor may need oiling. Correct as needed. b. Check installation — casing may be twisted or not level when installed. Expansion slip joint may be binding; check by removing vent cap assembly from outside wall. c. During normal furnace operation, motor will be on "LOW" speed when operating on minimum input capacity and on "HIGH" speed when operating on maximum input capacity. If there is no change in motor speed, replace selector switch.
9. Burner comes ON but goes OFF after operating for no apparent reason.*	Vent tube and air inlet tube improperly installed.	Check vent tube and air inlet tube. Follow installation instructions — be sure joints are tight and both tubes are in place. Use only tubes furnished. Do not extend tubes beyond original length.

\*Also applicable to Models 4007332, 5507332, 4007331 and 5507331.

- Continued Next Page -

**Troubleshooting Chart for Models  
4007332, 5507332, 4007331 and 5507331**

NOTE: Before troubleshooting the intermittent pilot system, be sure thermostat is turned to highest setting, gas shut-off valve and gas valve knob are in the ON position, and electric power is turned ON the furnace. Follow all steps in sequence. A volt-ohm meter will be needed to satisfactorily determine if any components are malfunctioning.

SYMPTOM	POSSIBLE CAUSE(S)	CORRECTIVE ACTION
1. No spark — no pilot gas.	<ul style="list-style-type: none"> <li>a. No main power.</li> <li>b. Faulty transformer.</li> <li>c. Faulty thermostat.</li> <li>d. Faulty limit switch.</li> <li>e. Faulty ignition control.</li> <li>f. Faulty wiring.</li> </ul>	<ul style="list-style-type: none"> <li>a. - e. Perform normal system checks of main power, transformer, thermostat, limit switch, and replace faulty component. With power ON, turn thermostat to the lowest setting, wait 10 seconds and return to HIGH setting. With power ON and thermostat set at its highest position, set voltmeter to 24V scale and attach probes to terminals "TR" and "TH" on the ignition control unit. If you read 24V and there is still no spark or pilot gas, the ignition control is defective and must be replaced.</li> <li>f. Test wiring. Repair or replace.</li> </ul>
2. Spark — but no pilot gas.	<ul style="list-style-type: none"> <li>a. Faulty ignition.</li> <li>b. No gas supplied to pilot valve.</li> <li>c. Manual valves in OFF positions.</li> <li>d. Faulty pilot valve.</li> <li>e. Faulty wiring.</li> <li>f. Restricted pilot line or clogged pilot orifice.</li> </ul>	<ul style="list-style-type: none"> <li>a. See 1.e.</li> <li>b. Check for availability of gas at gas control. Make sure the manual valve upstream of the gas control and the manual valve (gas cock) on the gas control are in the full ON position. No pilot gas could be caused by a plugged pilot tubing. Also check the pilot adjustment, at the gas control.</li> <li>c. See 2.b.</li> <li>d. See 2.b.</li> <li>e. See 1.f.</li> <li>f. See 2.b.</li> </ul>





**Troubleshooting Chart for Models  
4007332, 5507332, 4007331 and 5507331**

SYMPTOM	POSSIBLE CAUSE(S)	CORRECTIVE ACTION
4. Pilot lit — but main burner won't come ON (continued).	<p>d. Improper alignment of sensor in pilot flame.</p> <p>e. Faulty flame sensor.</p>	<p>d. When main burner comes ON, ensure that pilot flame is strong, sensor is properly aligned, and that pilot flame impinges the top 5/8 inch of the sensor. (See procedures for checking for proper pilot flame and alignment in problem 4.c.) Check the pilot and electrode assembly for proper electrode gap (3/32" to 1/8") or any possible shorting of electrode to surrounding metal surfaces. Make sure the spark ignitor and electrode connections to the ignition control are tight. The ignition control and pilot burner must both be chassis ground. If there is still no spark, the pilot and electrode assembly must be replaced.</p> <p>e. <b>BE SURE POWER IS OFF, BEFORE PERFORMING THIS TEST!!</b> Set test meter to "ohm" scale or use continuity checker. Touch one end of probes to tip of flame sensor, the other to "SENS" terminal on the ignition control. Ohmmeter should read "0", continuity should be evident. If you don't obtain a reading, remove wiring from sensor and test both individually. If continuity is not evident, replace wiring and/or sensor. There should be NO continuity between sensor and "GND" terminal on the ignition control. Testing wiring and sensor individually, determine which is shorted on ground. Replace or repair. Turn ON Power.</p>
5. Pilot cycles OFF and ON by itself.	<p>a. Faulty pilot valve.</p> <p>b. Faulty wiring.</p>	<p>a. See 2.b.</p> <p>b. See 1.f.</p>
6. Main burner shuts down before thermostat is satisfied.	<p>a. Low pilot flame.</p> <p>b. Improper alignment of sensor in pilot flame.</p> <p>c. Pilot flame being drawn away from sensor.</p> <p>d. Improper heat anticipator setting.</p> <p>e. Faulty limit.</p>	<p>a. See 4.C.</p> <p>b. See 4.d.</p> <p>c. When main burner comes ON, ensure that the pilot flame is strong and the sensor is properly aligned and that the pilot flame impinges the top 5/8 inch of the sensor. (See procedures for checking for proper pilot flame and alignment in problem 4.d.) If the pilot flame is drawn away from the sensor when the main burner comes ON, the cause could be the manual valve is not in the full ON position. <b>NOTE:</b> Low inlet gas pressure to the gas control can be caused by several problems and is not within the scope of the procedures outlined in this service guide. Consult your local utility or gas supplier.</p> <p>d. See 6.c. Check the setting of the heat anticipator in the wall thermostat. Set it to setting specified on the gas valve.</p> <p>e. The system may be cycling on a faulty limit. Using a test meter, set to the 110 volt scale, check for a voltage reading across the limit when the main burner shuts OFF. If you get a 24 volt or 110 volt reading on shut-down, replace defective limit.</p>

# WILLIAMS DIRECT VENT GAS-FIRED WALL FURNACE

REPAIR PARTS FOR MODELS —  
4007332, 4007331, 4007732 and 4007731

## CABINET and BODY ASSEMBLY

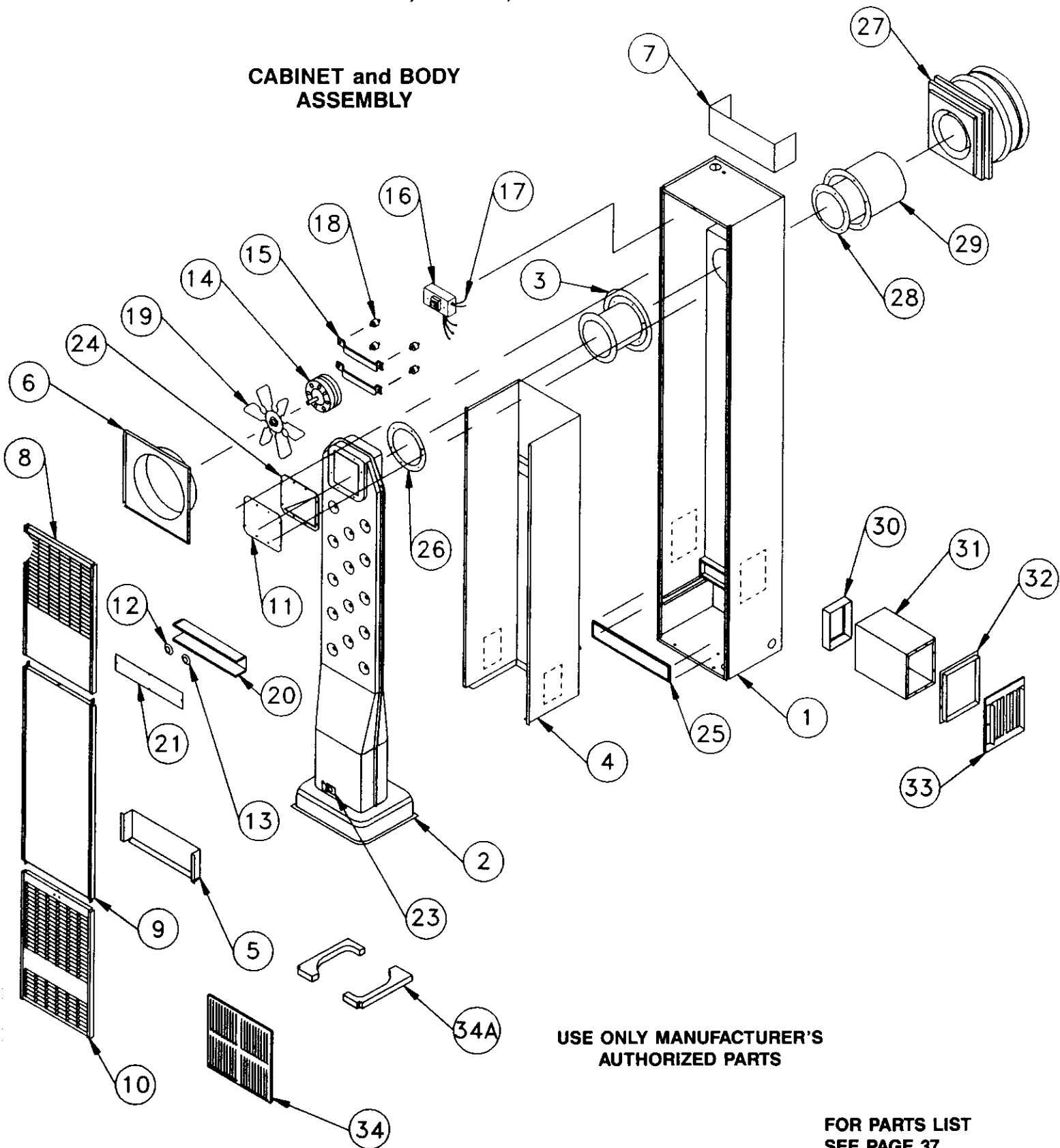

USE ONLY MANUFACTURER'S  
AUTHORIZED PARTS

FOR PARTS LIST  
SEE PAGE 37

# WILLIAMS DIRECT VENT GAS-FIRED WALL FURNACE

WILLIAMS DIRECT VENT  
GAS-FIRED WALL FURNACE  
FOR CONTROL ASSEMBLY MODELS—  
4007732 & 4007731

FOR PARTS LIST  
SEE PAGE 38

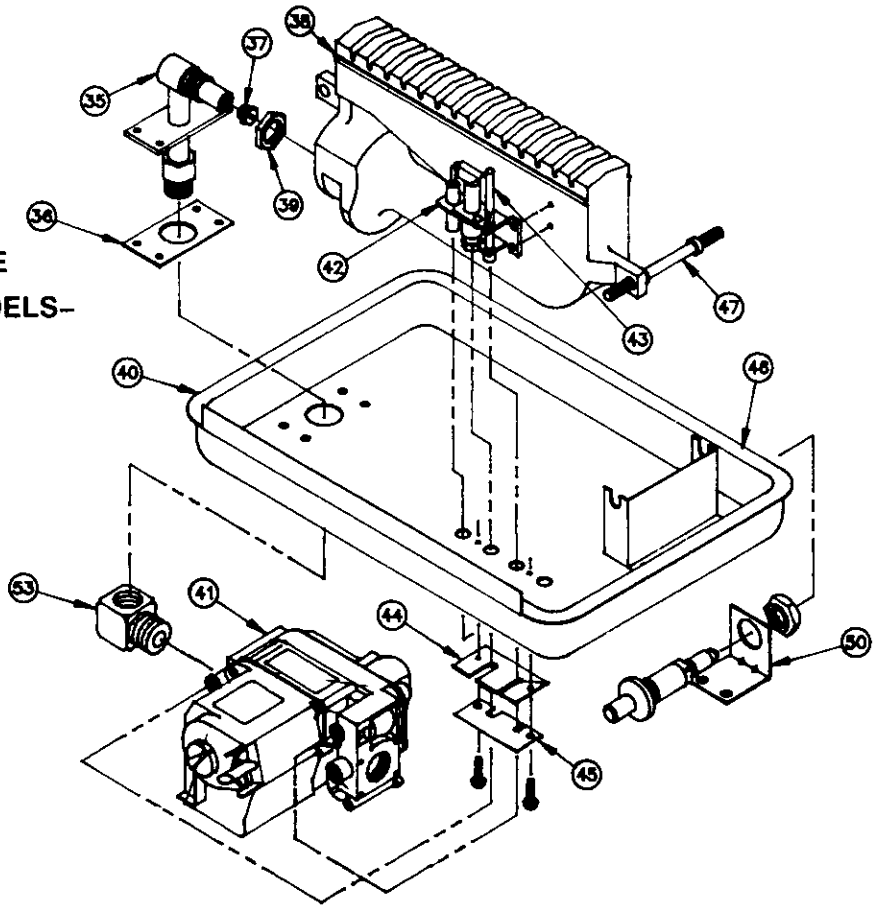
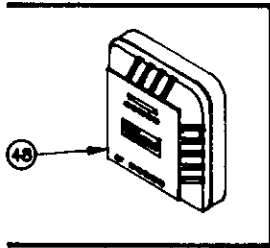

USE ONLY MANUFACTURER'S  
AUTHORIZED PARTS

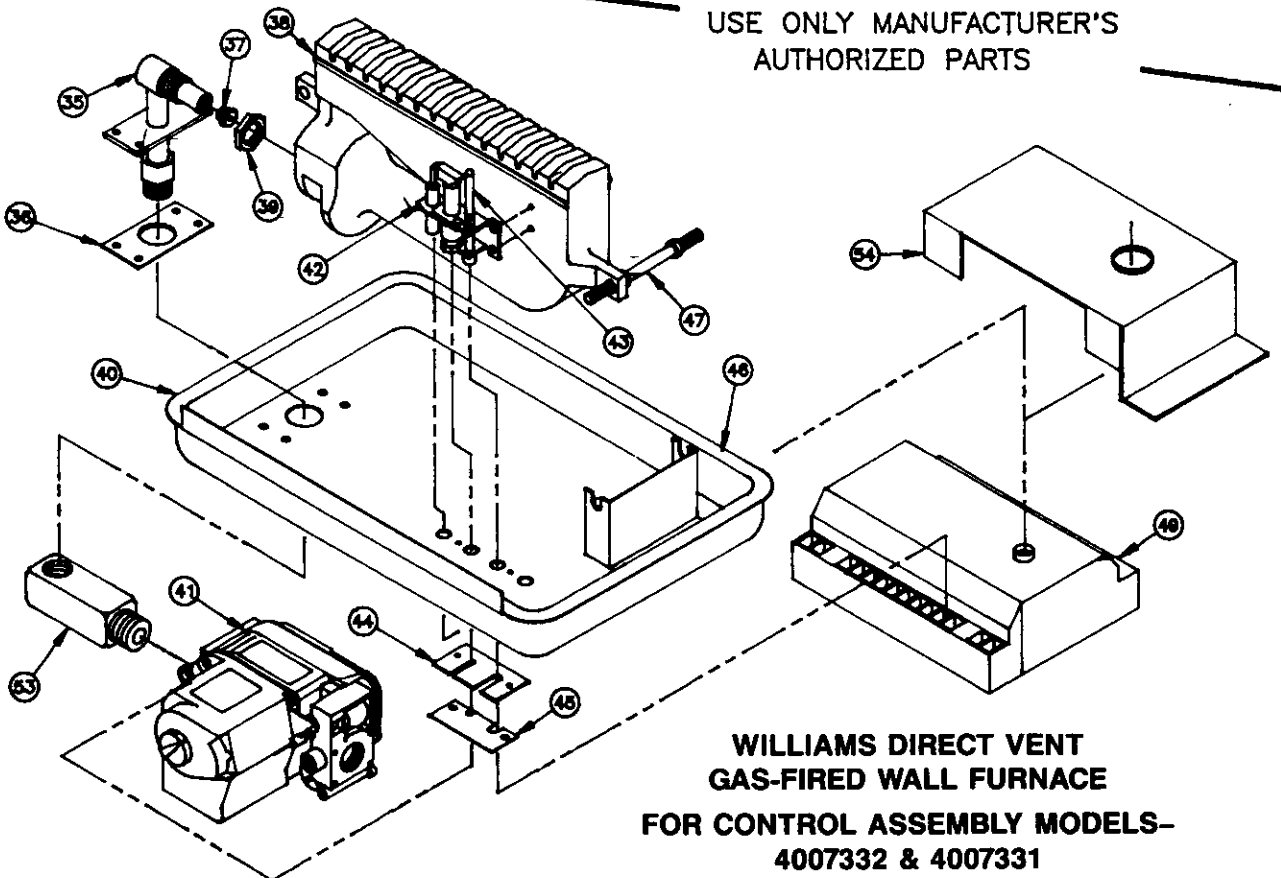

WILLIAMS DIRECT VENT  
GAS-FIRED WALL FURNACE  
FOR CONTROL ASSEMBLY MODELS—  
4007332 & 4007331

# WILLIAMS DIRECT VENT GAS-FIRED WALL FURNACE

## REPLACEMENT PARTS LIST FOR MODELS — 4007332, 4007732, 4007331 and 4007731

REF. NO.	DESCRIPTION	PART NO. FOR MODEL:			
		4007332	4007732	4007331	4007731
1	Outer Casing with Air Pan	11C42-2	11C42-2	11C42-2	11C42-2
2	Heating Element	11C67	11C67	11C67	11C67
3	Element Tube	11C37	11C37	11C37	11C37
4	Inner Liner	11B46	11B46	11B46	11B46
5	Deflector Baffle Handle	11C63	11C63	11C63	11C63
6	Fan Shroud	11B86	11B86	11B86	11B86
7	Top Trim Cover	11A40	11A40	11A40	11A40
8	Top Front Panel	11B102	11B102	11B102	11B102
9	Center Front Panel	11C62	11C62	11C62	11C62
10	Bottom Front Panel	11B103	11B103	11B103	11B103
11	Element Face Cover	11A103	11A103	11A103	11A103
12	Limit Switch	P200300	P200300	P200300	P200300
13	Fan Switch	P200200	P200200	P200200	P200200
14	Motor	P151101	P151101	P151101	P151101
15	Motor Support (2 Req.)	7B46	7B46	7B46	7B46
16	Transformer	P024200	P024200	P024200	P024200
17	Internal Wires (Except Ignition Control Wires For Models 4007332 & 4007331)	11A152	11A152	11A152	11A152
18	Vibration Mounts (4 Req.)	P022800	P022800	P022800	P022800
19	Fan Blade	P200600	P200600	P200600	P200600
20	Switch Box	11B05	11B05	11B05	11B05
21	Switch Box Cover	11C68	11C68	11C68	11C68
23	Peep Hole Cover	11A18	12B40	11A18	12B40
24	Element Face Gasket	P200900	P200900	P200900	P200900
25	Air Pan Tunnel Gasket	P151900	P151900	P151900	P151900
26	Seal Gasket	P103100	P103100	P103100	P103100
27	Vent Cap	11C09	11C09	11C09	11C09
28	Flue Extension	11A97	11A97	11A97	11A97
29	Air Inlet Extension	11B49	11B49	11B49	11B49
☆	★ 4701 Trim Strip Kit	4701	4701	4701	4701
30	★ Inner Boot				
31	★ Outer Boot				
32	★ Plaster Ground	6701	6701	6701	6701
33	★ 6702 Side Casing Grille Kit	6702	6702	6702	6702
34	★ 6703 Diffusing Grille Kit - Two-Way	6703	6703	6703	6703
	★ 6704 Diffusing Grille Kit - One-Way	6704	6704	6704	6704
34A	Gasket, Burner Pan (2 Req.)	P321020	P321020	P321020	P321020
☆	Owner's Manual	P321004	P321004	P321004	P321004

★ Not available separately, in kit form only  
 NOTE: Screws and bolts are standard hardware items, available locally.  
 ☆ Not shown.

For part illustration see page 35.

Continued

## WILLIAMS DIRECT VENT GAS-FIRED WALL FURNACE

### REPLACEMENT PARTS LIST FOR MODELS (Con't) — 4007332, 4007732, 4007331 and 4007731

REF. NO.	DESCRIPTION	PART NO. FOR MODEL:			
		4007332	4007732	4007331	4007731
35	Manifold	11B58	11B58	11B58	11B58
36	Manifold Gasket	P151700	P151700	P151700	P151700
37	Orifice Fitting, Specify Model & Gas	P090500	P090500	P090500	P090500
38	Burner, Cast Iron, Nat. or L.P.G.	P025600	P025600	P025600	P025600
39	Locknut (2 Req.)	P026200	P026200	P026200	P026200
40	Burner Pan	11C64-2	11C64-2	11C64-2	11C64-2
41	Valve, Williams Nat.	—	P322041	—	—
	Valve, Williams L.P.G.	—	—	—	P322042
	Valve, Williams Nat.	P322043	—	—	—
	Valve, Williams L.P.G.	—	—	P322044	—
42	Pilot, Cast Iron Burner, L.P.G.	—	—	P229200	P229200
	Pilot, Cast Iron Burner, Nat.	P229100	P229100	—	—
43	Thermocouple	—	P254000	—	P254000
	Flame Sensor	P271100	—	P271100	—
44	Pilot Tube Gasket	P151800	P151800	P151800	P151800
45	Pilot Tube Seal	11A41	11A41	11A41	11A41
46	Gasket 44 inch	P101600	P101600	P101600	P101600
47	Burner Spacer, Cast Iron Burner	P018100	P018100	P018100	P018100
48	Thermostat	P322017	P322017	P322017	P322017
49	Ignition Control Unit, Williams	P321910	—	P321910	—
50	Piezo Gas Lighter (Manual Spark Lighter)	—	P285500	—	P285500
53	Manifold Adapter	P321887	P321888	P321887	P321888
54	Ignition Shield	7C79	—	7C79	—
☆	Ignition Control Wires	31B036	—	31B036	—

★ Not available separately, in kit form only

NOTE: Screws and bolts are standard hardware items, available locally.

☆ Not shown.

For part illustration see page 36.

WILLIAMS DIRECT VENT GAS-FIRED WALL FURNACE

FURNACE ASSEMBLY FOR MODELS —  
5507332 and 5507331

CABINET and BODY  
ASSEMBLY

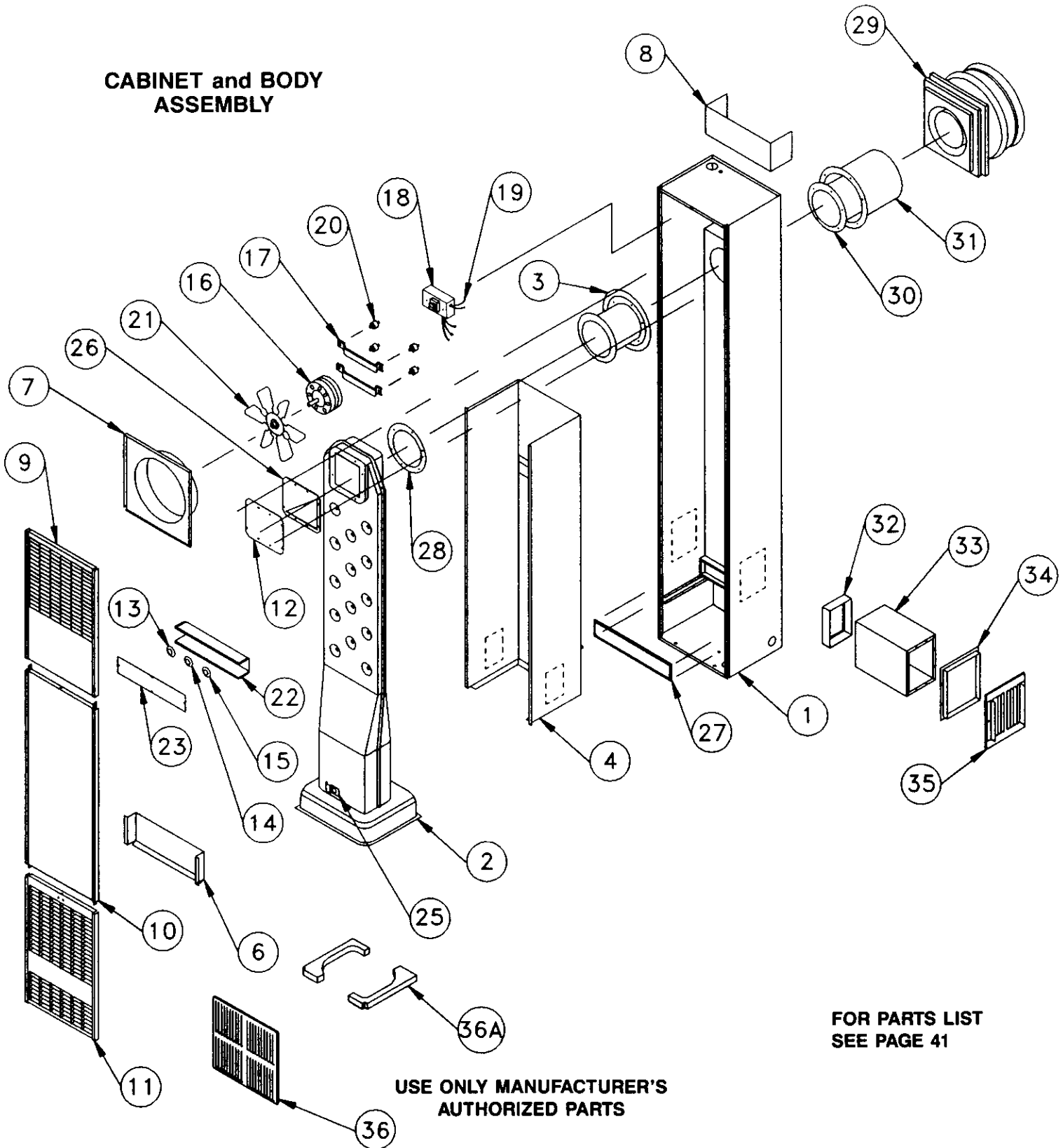

FOR PARTS LIST  
SEE PAGE 41

USE ONLY MANUFACTURER'S  
AUTHORIZED PARTS

# WILLIAMS DIRECT VENT GAS-FIRED WALL FURNACE

**WILLIAMS DIRECT VENT  
GAS-FIRED WALL FURNACE  
FOR CONTROL ASSEMBLY MODELS-  
6257732 & 6257731**

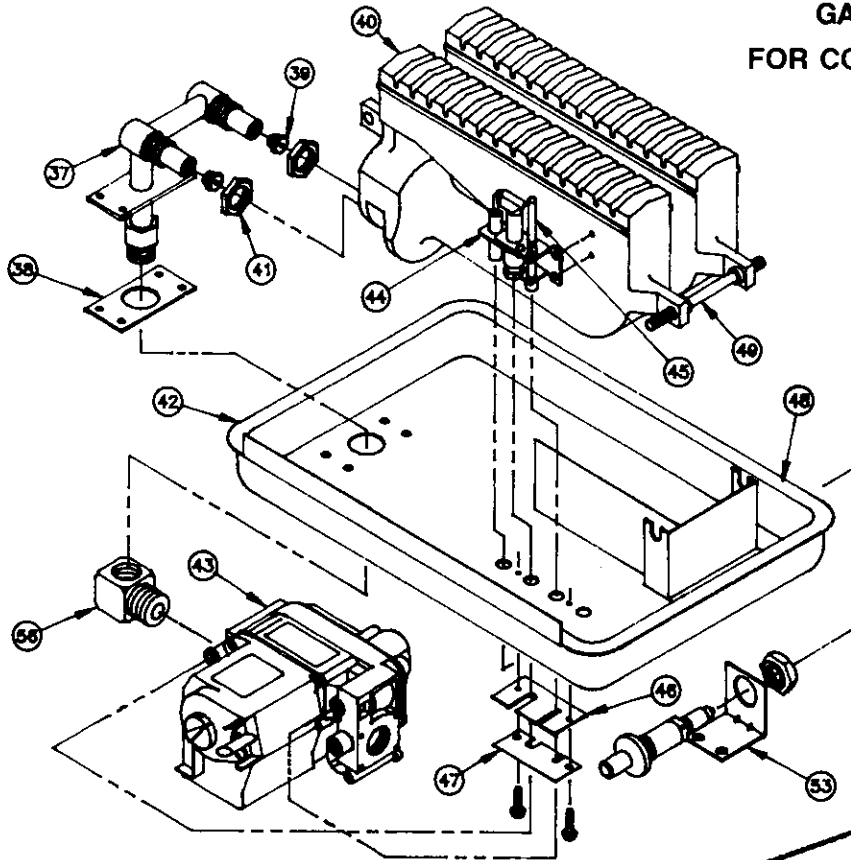

FOR PARTS LIST  
SEE PAGE 42

USE ONLY MANUFACTURER'S  
AUTHORIZED PARTS

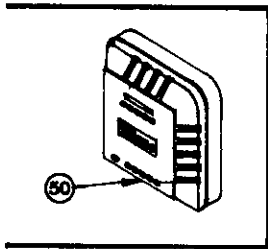

**WILLIAMS DIRECT VENT  
GAS-FIRED WALL FURNACE  
FOR CONTROL  
ASSEMBLY MODELS-  
5507332 & 5507331**

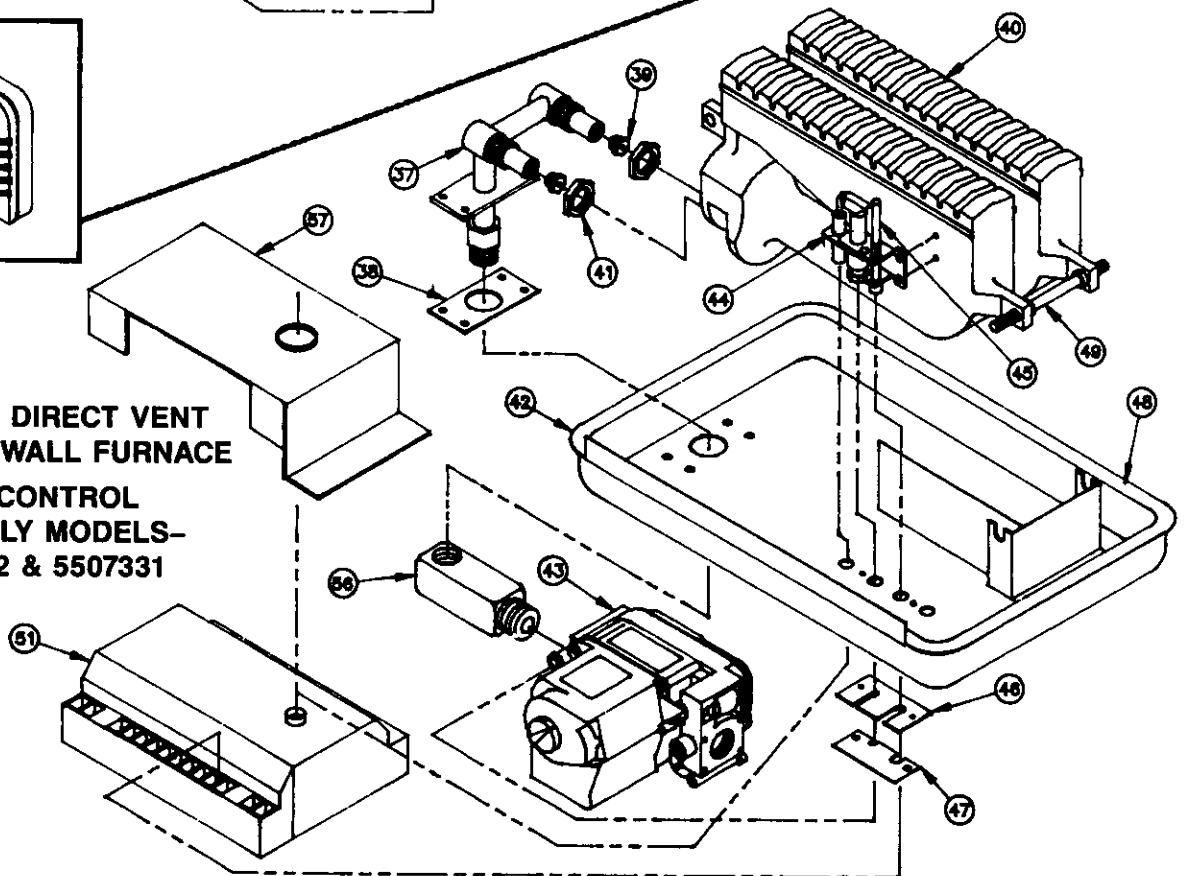



# WILLIAMS DIRECT VENT GAS-FIRED WALL FURNACE

## REPLACEMENT PARTS LIST FOR MODELS — 5507332 and 5507331

REF. NO.	DESCRIPTION	PART NO. FOR MODEL:	
		5507332	5507331
1	Outer Casing with Air Pan	11C42-1	11C42-1
2	Heating Element	11C66	11C66
3	Element Tube	11C37	11C37
4	Inner Liner	7B79	7B79
6	Deflector Baffle Handle	11C63	11C63
7	Fan Shroud	11B86	11B86
8	Top Trim Cover	11A40	11A40
9	Top Front Panel	11B102	11B102
10	Center Front Panel	11C59	11C59
11	Bottom Front Panel	11B103	11B103
12	Element Face Cover	11A103	11A103
13	Limit Switch	P296001	P296001
14	Selector Switch	P200400	P200400
15	Fan Switch	P200200	P200200
16	Motor	P062101	P062101
17	Motor Support (2 Req.)	7B46	7B46
18	Transformer	P024200	P024200
19	Internal Wires (Except ignition control wires)	7A194	7A194
20	Vibration Mounts (4 Req.)	P022800	P022800
21	Fan Blade	P200600	P200600
22	Switch Box	11B05	11B05
23	Switch Box Cover	11C68	11C68
25	Peep Hole Cover	12B40	12B40
26	Element Face Gasket	P200900	P200900
27	Air Pan Tunnel Gasket	P151900	P151900
28	Seal Gasket	P103100	P103100
29	Vent Cap	11C09	11C09
30	Flue Extension	11A97	11A97
31	Air Inlet Extension	11B49	11B49
☆	★ 4701 Trim Strip Kit	4701	4701
32	★ Inner Boot		
33	★ Outer Boot		
34	★ Plaster Ground	6701	6701
35	★ 6702 Side Casing Grille Kit	6702	6702
36	★ 6703 Diffusing Grille Kit - Two-Way	6703	6703
36	★ 6704 Diffusing Grille Kit - One-Way	6704	6704
36A	Gasket, Burner Pan (2 Req.)	P321020	P321020
☆	Owner's Manual	P321004	P321004

★ Not available separately, in kit form only

NOTE: Screws and bolts are standard hardware items, available locally.

☆ Not shown.

For part illustration see page 39.

Continued

## WILLIAMS DIRECT VENT GAS-FIRED WALL FURNACE

### REPLACEMENT PARTS LIST FOR MODELS (Con't) — 5507332, 6257732, 5507331 and 6257731

REF. NO.	DESCRIPTION	PART NO. FOR MODEL:			
		5507332	6257732	5507331	6257731
37	Manifold	11B57	11B57	11B57	11B57
38	Manifold Gasket	P151700	P151700	P151700	P151700
39	Orifice Fitting, Specify Model & Gas	P090500	P090500	P090500	P090500
40	Burner, Cast Iron, Nat. or L.P.G. (2 req.)	P025600	P025600	P025600	P025600
41	Locknut (2 Req.)	P026200	P026200	P026200	P026200
42	Burner Pan	11C64-1	11C64-1	11C64-1	11C64-1
43	Valve, Williams Nat.	—	P322041	—	—
	Valve, Williams L.P.G.	—	—	—	P322042
43	Valve, Williams Nat.	P322043	—	—	—
	Valve, Williams L.P.G.	—	—	P322044	—
44	Pilot, Cast Iron Burner, L.P.G.	—	—	P229200	P229200
	Pilot, Cast Iron Burner, Nat.	P229100	P229100	—	—
45	Thermocouple	—	P254000	—	P254000
	Flame Sensor	P271100	—	P271100	—
46	Pilot Tube Gasket	P151800	P151800	P151800	P151800
47	Pilot Tube Seal	11A41	11A41	11A41	11A41
48	Gasket 44 inch	P101600	P101600	P101600	P101600
49	Burner Spacer, Cast Iron Burner	P018100	P018100	P018100	P018100
50	Thermostat	P322017	P322017	P322017	P322017
51	Ignition Control Unit, Williams	P321910	—	P321910	—
53	Piezo Gas Lighter (Manual Spark Lighter)	—	P285500	—	P285500
56	Manifold Adapter	P321887	P321888	P321887	P321888
57	Ignition Shield	7C79	—	7C79	—
☆	Ignition Control Wires	31B036	—	31B036	—

★ Not available separately, in kit form only For part illustration see page 40.  
 NOTE: Screws and bolts are standard hardware items, available locally.  
 ☆ Not shown.

WILLIAMS DIRECT VENT GAS-FIRED WALL FURNACE

FURNACE ASSEMBLY FOR MODELS —  
6257732 and 6257731

CABINET and BODY  
ASSEMBLY

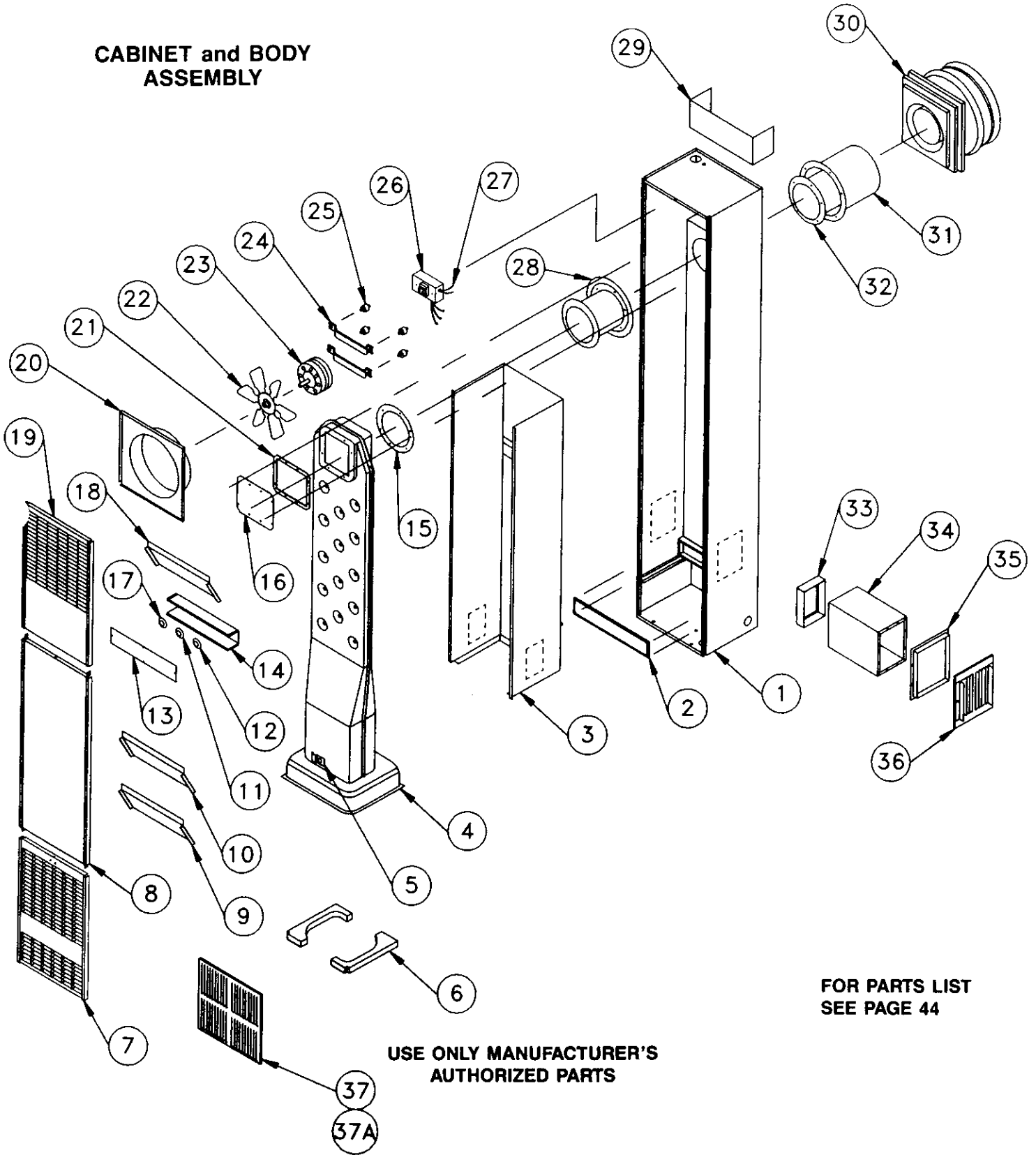

FOR PARTS LIST  
SEE PAGE 44

# WILLIAMS DIRECT VENT WALL FURNACE

## REPLACEMENT PARTS LIST FOR MODELS— 6257732 and 6257731

REF. NO.	DESCRIPTION	PART NO. FOR MODEL:	
		6257732	6257731
1	OUTER CASING W/. AIR PAN	11C42-1	11C42-1
2	AIR PAN TUNNEL GASKET	P151900	P151900
3	INNER LINER	11B120	11B120
4	HEATING ELEMENT	11C66	11C66
5	PEEPHOLE COVER	12B40	12B40
6	BURNER PAN GASKET (2 REQ.)	P321020	P321020
7	BOTTOM FRONT PANEL	11B103	11B103
8	CENTER FRONT PANEL	11C59	11C59
9	BOTTOM AIR DEFLECTOR	11B123	11B123
10	CENTER AIR DEFLECTOR	11B119	11B119
11	SELECTOR SWITCH	P200400	P200400
12	FAN SWITCH	P200200	P200200
13	SWITCH BOX COVER	11C68	11C68
14	SWITCH BOX	11B05	11B05
15	SEAL GASKET	P103100	P103100
16	ELEMENT BAFFLE	11B116	11B116
17	LIMIT SWITCH	P321942	P321942
18	TOP AIR DEFLECTOR	11B119	11B119
19	TOP FRONT PANEL	11B102	11B102
20	FAN SHROUD	11B86	11B86
21	ELEMENT FACE GASKET	P304000	P304000
22	FAN BLADE	P200600	P200600
23	MOTOR	P321601	P321601
24	MOTOR SUPPORT (2 REQ.)	7B46	7B46
25	VIBRATION MOUNTS (4 REQ.)	P022800	P022800
26	TRANSFORMER	P024200	P024200
27	INTERNAL WIRES	6257732	6257731
28	ELEMENT TUBE	11C37	11C37
29	TOP TRIM COVER	11A40	11A40
30	VENT CAP	11C09	11C09
31	FLUE EXTENSION	9801 KIT	11A97
32	AIR INLET EXTENSION		11B49
33	☆ INNER BOOT	6701 SIDE OUTLET KIT	6701
34	☆ OUTER BOOT		
35	☆ PLASTERGROUND		
36	☆ 6702 SIDE CASING GRILLE KIT	6702	6702
37	☆ 6703 DIFFUSING GRILLE KIT - 2 WAY	6703	6703
37A	☆ 6704 DIFFUSING GRILLE KIT - 1 WAY	6704	6704
	☆ 4701 TRIM STRIP KIT (NOT SHOWN)	4701	4701

☆ Not available separately, in kit form only. For parts illustration see page 43

NOTE: Screws and bolts are standard hardware items, available locally.

*Service Record*

DATE	MAINTENANCE PERFORMED	COMPONENTS REQUIRED







**owners  
manual**

**SERVICE**

**MODEL NOS.**

- 4007332**
- 4007732**
- 5507332**
- 6257732**
- 4007331**
- 4007731**
- 5507331**
- 6257731**

**Service Hints**

If your furnace fails to work right, you may avoid inconvenience and the cost of a service call by checking the following points before you call for service.

FOR YOUR SAFETY	FOR YOUR SAFETY
Do not store or use gasoline or other flammable vapors and liquids in the vicinity of this or any other appliance.	If you smell gas: 1. Open windows. 2. Don't touch electrical. 3. Extinguish any open flame. 4. Immediately call your gas supplier.

**POSSIBLE CAUSE**

**WHAT TO DO**

**If fan motor is noisy —**

- Housing rattling.
- Fan dirty.
- Fan blade bent.
- Motor bearings need oiling.

- Tighten screws.
- Clean fan blade.
- Replace fan blade.
- Oil motor.

**If fan does not run -**

- Fuse blown or tripped circuit breaker.
- Motor bearings need oiling.

- Replace fuse or reset breaker.
- Oil motor.

**If burner is noisy —**

- Pilot observation door loose or missing. (peep hole cover)

- Tighten wingnut or replace door.

**If your furnace is not heating or not giving enough heat —**

- Fuse blown or tripped circuit breaker.
- Thermostat is not set correctly.
- Air flow restricted.

- Replace fuse or reset breaker.
- Reset thermostat to desired setting.
- Check that doors, drapes or furniture are not blocking furnace louvers.

**If your furnace short cycles —**

- Thermostat anticipator not set correctly.

- Set anticipator (See Page 11).

**If your furnace pops and cracks —**

- Heat exchanger expansion and contraction.

- Normal condition, especially with newer furnaces.

See troubleshooting section for more detailed information.

Illustrations are representative only.  
Specifications are subject to change without notice.

**How to Order Repair Parts**

When ordering repair parts, always give the following information:

- 1. MODEL NUMBER
- 2. MFG. DATE CODE
- 3. PART NUMBER
- 4. PART DESCRIPTION

All parts listed herein may be ordered from your equipment supplier.

The Model Number of your Williams wall furnace will be found on the rating plate near gas valve, inside control compartment.



**WILLIAMS FURNACE COMPANY**  
225 Acacia Street  
Colton, CA 92324 USA  
(909) 825-0993

MANUFACTURED  
IN THE U.S.A.  
Established 1916  
FAX: (909) 824-8009