

Use & Care Guide  
Manual de Uso y Cuidado

# Kenmore®

## Microwave Oven

1.5 Cu. Ft., 1000 Watts

## Horno de Microondas

1.5 Pies.Cúbicos, 1000 Vatios

**Models/Modelos:**

111.71519810 - Black / Negro

111.71513810 - Stainless Steel / Acero Inoxidable

**Customer Assistance/Asistencia al Cliente**

1-844-553-6667 press 2/presione 2

Sears Brands Management Corporation  
Hoffman Estates, IL 60179 U.S.A.  
[www.kenmore.com](http://www.kenmore.com)  
[www.sears.com](http://www.sears.com)



## **IMPORTANT!**

### **FAN OPERATION NOTICE**

At the end of longer cooking cycles it is normal operation for the fan to continue running to cool the oven electronic system. After 5 minutes with no further cooking activity the fan will automatically shut off. However, you can begin a new cooking cycle even while the fan is running.

# PRECAUTIONS TO AVOID POSSIBLE EXPOSURE TO EXCESSIVE MICROWAVE ENERGY

- (a) Do not attempt to operate this oven with the door open since this can result in harmful exposure to microwave energy. It is important not to defeat or tamper with the safety interlocks.
- (b) Do not place any object between the oven front face and the door or allow soil or cleaner residue to accumulate on sealing surfaces.
- (c) Do not operate this oven if it is damaged. It is particularly important that the oven door close properly and that there is no damage to the:
  - (1) DOOR (bent) or DOOR METAL SCREEN (cracks or breaks)
  - (2) HINGES AND LATCHES (broken or loosened)
  - (3) DOOR SEALS AND SEALING SURFACES
- (d) The oven should not be adjusted or repaired by anyone except properly qualified service personnel.
- (e) **WARNING** : It is hazardous for anyone other than a competent person to carry out any service or repair operation that involves the removal of a cover which gives protection against exposure to microwave energy.
- (f) **WARNING** : Liquids and other foods must not be heated in sealed containers since they are liable to explode.
- (g) **WARNING** : Only allow children to use the oven without supervision when adequate instructions have been given so that the child is able to use the oven in a safe way and understands the hazards of improper use.
- (h) **WARNING** : When the appliance is operated in the combination mode, children should only use the oven under adult supervision due to the temperature generated. (if provided)

## Specifications

Model:	111.71513810 / 111.71519810
Rated Voltage:	120V~ 60Hz
Rated Input Power(Microwave):	1650 W
Rated Output Power(Microwave):	1000 W
Grill:	1200 W
Convection:	1450 W
Combination:	1700 W
Oven Capacity:	1.5 cu.ft. / 42 L
Turntable Diameter:	Ø 13.4 inch / 340 mm
External Dimensions:	22.9X22.0X14.9 inch (582X559X379 mm)
Net Weight:	Approx. 48.9 Lbs (22.2 kg)

# IMPORTANT SAFETY INSTRUCTIONS

**WARNING** To reduce the risk of burns, electric shock, fire, injury to persons or exposure to excessive microwave oven energy when using your appliance, follow basic safety precautions, including the following:

1. Read all instructions before using the appliance.
2. Read and follow the specific: "PRECAUTIONS TO AVOID POSSIBLE EXPOSURE TO EXCESSIVE MICROWAVE ENERGY" found on page 1.
3. As with most cooking appliances, close supervision is necessary to reduce the risk of a fire in the oven cavity.
4. To reduce the risk of fire in the oven cavity:
  - i) Do not overcook food. Carefully attend the appliance when paper, plastic, or other combustible materials are placed inside the oven to facilitate cooking.
  - ii) Remove wire twist-ties and metal handles from paper or plastic containers/bags before placing them in the oven.
  - iii) If materials inside the oven ignite, keep the oven door closed. Turn the oven off, and unplug the appliance. Disconnect the power cord, shut off power at the fuse or circuit breaker panel.
  - iv) Do not use the oven cavity for storage purposes. Do not leave paper products, cooking utensils, or food in the cavity when not in use.
  - v) Never operate an empty microwave oven. Arcing or sparking in the oven cavity may occur.
5. This oven must be grounded. Connect only to properly grounded outlet. See "GROUNDING INSTRUCTIONS" found on page 3.
6. Install or locate this oven only in accordance with the installation instructions provided.
7. Some products such as whole eggs and sealed containers-for example, closed glass jars- are able to explode and should not be heated in the oven.
8. Use this appliance only for its intended uses as described in this manual. Do not use corrosive chemicals or vapors in this appliance. This oven is specifically designed to heat or cook or dry food. It is not designed for industrial or laboratory use.
9. As with any appliance, close supervision is necessary when used by children.
10. Do not operate this oven if it has a damaged cord or plug, if it is not working properly or if it has been damaged or dropped.
11. **This microwave should be serviced only by qualified service personnel.**
12. Do not cover or block any openings on the oven.
13. Do not store or use this appliance outdoors.
14. Do not use this oven near water, for example, near a kitchen sink, in a wet basement, near a swimming pool, or similar locations.
15. Do not immerse cord or plug in water.
16. Keep cord away from heated surfaces.
17. Do not let cord hang over edge of table or counter.
18. When cleaning surfaces of door and oven that come together on closing the door, use only mild, nonabrasive soaps or detergents applied with a sponge or soft cloth.
19. Do not consume foods immediately after the oven finishes cooking. Heated foods, especially pizza, may burn your mouth. Allow foods to cool to a safe eating temperature.
20. **This appliance is for private household use only.**

21. Liquids, such as water, coffee, or tea are able to be overheated beyond the boiling point without appearing to be boiling. Visible bubbling or boiling when the container is removed from the microwave oven is not always present. THIS COULD RESULT IN VERY HOT LIQUIDS SUDDENLY BOILING OVER WHEN THE CONTAINER IS DISTURBED OR A SPOON OR OTHER UTENSIL IS INSERTED INTO THE LIQUID.
  - i) Do not overheat the liquid.
  - ii) Stir the liquid both before and halfway through heating it.
  - iii) Do not use straight-sided containers with narrow necks.
  - iv) After heating, allow the container to stand in the microwave oven for a short time before removing the container.
  - v) Use extreme care when inserting a spoon or other utensil into the container.
22. Oversized foods or oversized metal utensils should not be inserted in a microwave oven as they may create a fire or risk of electric shock.
23. Do not clean with metal scouring pads. Pieces can burn off the pad and touch electrical parts involving a risk of electric shock.
24. Do not store any materials, other than manufacturer's recommended accessories, in this oven when not in use.
25. Do not cover racks or any other part of the oven with metal foil. This will cause overheating of the oven.
26. Do not operate the oven without the glass tray in place. Be sure it is properly sitting on the rotating base.

## SAVE THESE INSTRUCTIONS

# GROUNDING INSTRUCTIONS

## DANGER

Electric Shock Hazard

Touching some of the internal components can cause serious personal injury or death. Do not disassemble this appliance.

## DANGER

Electric Shock Hazard

An improperly grounded appliance can result in electric shock. Do not plug into an outlet until appliance is properly installed and grounded.

**Three-pronged (grounding) plug**

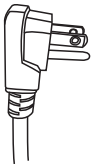

This appliance must be grounded. In the event of an electrical short circuit, grounding reduces the risk of electric shock by providing an escape wire for the electric current. To protect against electrical shock, this appliance is equipped with a cord having a 3-prong grounding-type plug for insertion into a proper grounding-type receptacle. **DO NOT** alter the plug for use in a 2-prong receptacle. **DO NOT** use a 3-prong adapter to enable the microwave to be plugged into a 2-prong receptacle. If the plug will not fit into a receptacle, have the proper receptacle installed by a qualified electrician.

Consult a qualified electrician or serviceman if the grounding instructions are not completely understood or if doubt exists as to whether the appliance is properly grounded. If it is necessary to use an extension cord, use only a 3-wire extension cord that has a 3-pronged grounding plug, and a 3-slot receptacle that will accept the plug on the appliance. The marked rating of the extension cord shall be equal to or greater than the electrical rating of the appliance.

1. A short power-supply cord is provided to reduce the risks resulting from becoming entangled in or tripping over a longer cord.
2. Longer cord sets or extension cords are available and may be used if care is exercised in their use.
3. If a long cord sets or extension cord is used:
  - i) The marked electrical rating of the cord set or extension marked electrical rating of the cord set or extension cord should be at least as great as the electrical rating of the appliance.
  - ii) The extension cord must be a grounding-type 3-wire cord.
  - iii) The longer cord should be arranged so that it will not drape over the countertop or tabletop where it can be pulled on by children or tripped over unintentionally.

# RADIO FREQUENCY INTERFERENCE STATEMENT FEDERAL COMMUNICATIONS COMMISSION (U.S.A ONLY)

## **WARNING:**

This equipment generates and uses ISM frequency energy and if not installed and used properly, that is in strict accordance with the manufacturer's instructions, may cause interference to radio and television reception.

It has been type-tested and found to comply with limits for an ISM equipment pursuant to part 18 of FCC rules, which are designed to provide reasonable protection against such interference in a residential installation.

However, there is no guarantee that interference will not occur in a particular installation.

If this equipment does cause interference to radio or television reception, which can be determined by turning the equipment off and on, the user is encouraged to try correct the interference by one or more of the followings.

- Reorient the receiving antenna of radio or television.
- Relocate the microwave oven with respect to the receiver.
- Move the microwave oven away from the receiver.
- Plug the microwave oven into a different outlet so that microwave oven and receiver are on different branch circuits.

THE MANUFACTURER is not responsible for any radio or TV interference caused by UNAUTHORIZED MODIFICATION to this microwave oven. It is the responsibility of the user to correct such interference.

## **CAUTION**

Personal injury Hazard  
Tightly-closed utensils  
could explode. Closed  
containers should be opened  
and plastic pouches should be  
pierced before cooking.

## **UTENSILS**

See the instructions on "Materials you can use in  
microwave oven or to be avoided in microwave oven."  
There may be certain non-metallic utensils that are not  
safe to use for microwaving. If in doubt, you can test the  
utensil in question following the procedure below.

Utensils Test:

1. Fill a microwave-safe container with 1 cup of cold water (250ml) along with the utensil in question.
2. Cook on maximum power for 1 minute.
3. Carefully feel the utensil. If the empty utensil is warm, do not use it for microwave cooking.
4. Do not exceed 1 minute cooking time.

# SAFE AND UNSAFE MATERIALS

## Materials you can use in microwave oven

Utensils	Remarks
Aluminum foil	Shielding only. Small smooth pieces can be used to cover thin parts of meat or poultry to prevent overcooking. Arcing can occur if foil is too close to oven walls. The foil should be at least 1 inch (2.5cm) away from oven walls.
Browning dish	Follow manufacturer's instructions. The bottom of browning dish must be at least 3/16 inch (5 mm) above the turntable. Incorrect usage may cause the turntable to break.
Dinnerware	Microwave-safe only. Follow manufacturer's instructions. Do not use cracked or chipped dishes.
Glass jars	Always remove lid. Use only to heat food until just warm. Most glass jars are not heat resistant and may break.
Glassware	Heat-resistant oven glassware only. Make sure there is no metallic trim. Do not use cracked or chipped dishes.
Oven cooking bags	Follow manufacturer's instructions. Do not close with metal tie. Make slits to allow steam to escape.
Paper plates and cups	Use for short-term cooking/warming only. Do not leave oven unattended while cooking.
Paper towels	Use to cover food for reheating and absorbing fat. Use with supervision for a short-term cooking only.
Parchment paper	Use as a cover to prevent splattering or a wrap for steaming.
Plastic	Microwave-safe only. Follow the manufacturer's instructions. Should be labeled "Microwave Safe". Some plastic containers soften as the food inside gets hot. "Boiling bags" and tightly closed plastic bags should be slit, pierced or vented as directed by instructions on package.
Plastic wrap	Microwave-safe only. Use to cover food during cooking to retain moisture. Do not allow plastic wrap to touch food.
Thermometers	Microwave-safe only ( meat and candy thermometers).
Wax paper	Use as a cover to prevent splattering and retain moisture.

## Materials to be avoided in microwave oven

Utensils	Remarks
Aluminum tray	May cause arcing. Transfer food into microwave-safe dish.
Food carton with metal handle	May cause arcing. Transfer food into microwave-safe dish.
Metal or metal-trimmed utensils	Metal shields the food from microwave energy. Metal trim may cause arcing.
Metal twist ties	May cause arcing and could cause a fire in the oven.
Paper	May cause a fire in the oven.
Plastic foam	Plastic foam may melt or contaminate the liquid inside when exposed to high temperature.
Wood	Wood will dry out when used in the microwave oven and may split or crack.



# SETTING UP YOUR OVEN

## Names of oven Parts and Accessories

Remove the oven and all materials from the carton and oven cavity.

Your oven comes with the following accessories:

Glass tray	1
Turntable ring	1
Use & Care Guide	1
Low Rack	1
High Rack	1

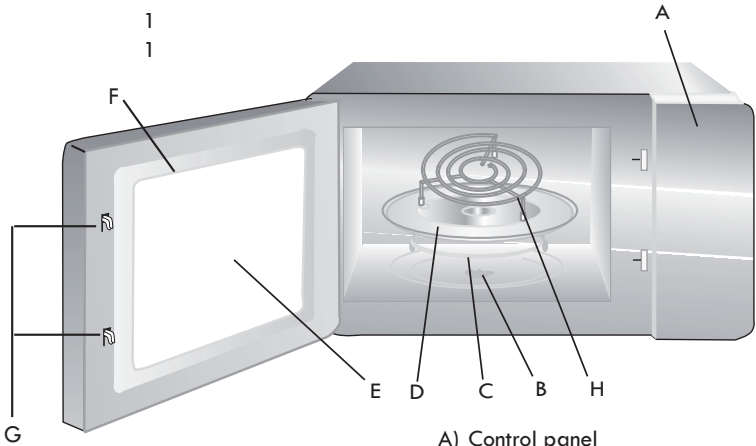

- A) Control panel
- B) Turntable shaft
- C) Turntable ring
- D) Glass tray
- E) Observation window
- F) Oven Door
- G) Safety interlock system
- H) Rack (\*Optional)

## Turntable Installation

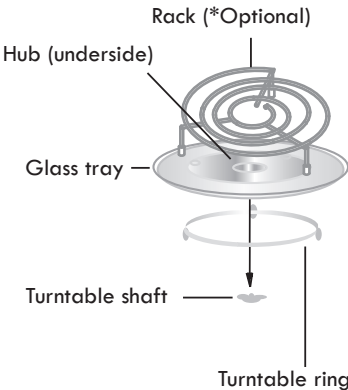

- a. Never place the glass tray upside down. The glass tray should never be restricted.
- b. Both glass tray and turntable ring must always be used during cooking.
- c. All food and containers of food are always to be placed on the glass tray for cooking.
- d. If glass tray or turntable ring cracks or breaks, contact the following customer assistance number:  
1-800-657-6119

## Countertop Installation

Remove all packing material and accessories. Examine the oven for any damage such as dents or broken door. Do not install if oven is damaged.

**Cabinet:** Remove any protective film found on the microwave oven cabinet surface. **Do not remove the off-white Mica cover that is attached to the oven cavity to protect the magnetron.**

---

## Installation

1. Select a level surface that provide enough open space for the intake and/or outlet vents.

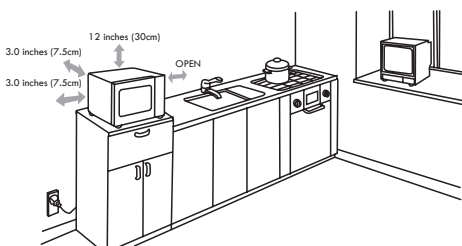

A minimum clearance of 3.0 inches (7.5cm) is required between the oven and any adjacent walls. One side must be open.

- (1) Leave a minimum clearance of 12 inches (30cm) above the oven.
- (2) Do not remove the legs from the bottom of the oven.

- (3) Blocking the intake or outlet vent openings can damage the oven.
  - (4) Place the oven as far away from radios and TV as possible. Operation of microwave oven may cause interference to your radio or TV reception.
2. Plug your oven into a standard household outlet. Be sure the voltage and the frequency is the same as the voltage and the frequency on the rating label.

**WARNING:** Do not install oven over a range cooktop or other heat-producing appliance. If installed near or over a heat source, the oven could be damaged and the warranty would be void.

# OPERATION

## Control Panel and Features

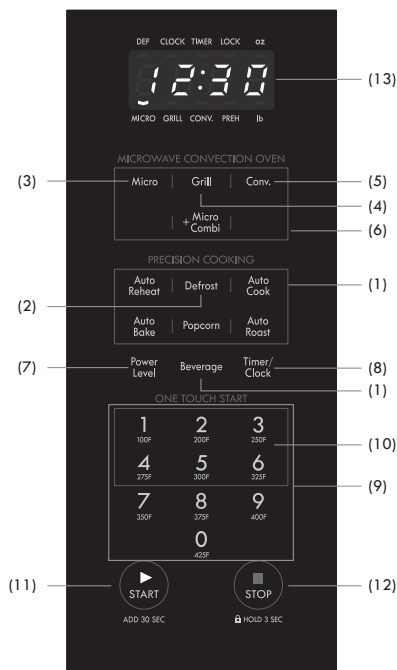

- (1) **Auto Menu (Auto Reheat, Auto Cook, Auto Bake, Auto Roast, Popcorn, Beverage)**  
Auto Menu items allow you to easily program cooking time based on food quantity.
- (2) **Defrost** : Defrost time calculated by entered weight and category of item.
- (3) **Micro** - Press for Microwave only cooking
- (4) **Grill** - Press for Grill only cooking
- (5) **Conv** - Press for Convection only cooking
- (6) **Micro + Conv** - Press for combined Microwave + Convection cooking
- (7) **Power Level**
- (8) **Timer / Clock**
- (9) **Number Pads**
- (10) **ONE TOUCH START Pads (1-6)**
- (11) **START / ADD 30 SEC**
- (12) **STOP / Hold 3sec** : Before cooking starts, press to clear all previous settings.  
During cooking, press once to stop oven; press twice to stop oven and clear all settings.  
Press pad for 3 seconds to lock or unlock display
- (13) **Display Window**

# OPERATION

## CLOCK SETTING

When the microwave oven is plugged into an outlet, " : 0" will display.

- (1) Press Timer/Clock once, "12H" will appear in the display.
- (2) Press the number pads and enter the current clock time. For example, if the time is now 8:30, press "8, 3, 0" in order. The numbers will flash in the display.
- (3) Press Timer/Clock to finish clock setting, ":" will flash and the numbers will appear as a clock time in the display.

Note: (1) If you make a number entry mistake while in the process of setting clock, press  to start over.

- (2) This is a 12 hour clock. If the numbers entered are not within the range between 1:00 to 12:59, the setting will not be accepted until valid numbers are entered.

## TIMER

- (1) Press Timer/Clock twice, " : 0" and TIMER indicator "v" will appear in the display window.
- (2) Press the number pads to enter the time amount. The maximum amount of time that can be enter is 99 minutes 99 seconds.
- (3) Press  to confirm setting.
- (4) When the time amount elapses, the control panel will beep 3 times.

Note: The Timer setting is different from the Clock setting; it is simply a timer.

## MICROWAVE COOK

- (1) Press Micro, " : 0" and MICRO (Microwave) indicator "v" will appear in the display window.
- (2) Press number pads to enter the cooking time; the maximum cooking time is 99 minutes and 99 seconds.
- (3) Press Power Level ; PL10 will display. This is the default power level of 100%. Press number pads 0 through 9 to select a different power level if desired. See the Power Level table below.
- (4) Press  to start cooking.

Example: To cook the food with 50% microwave power for 15 minutes.

- a. Press the Time Cook, " : 0" and M/W (Microwave) indicator "v" will appear in the display window.
- b. Press "1, 5, 0, 0" in order for 15:00 to appear in the display.
- c. Press Power Level, then press "5" to select 50% microwave power.
- d. Press  to start cooking.

Note: In the process of setting, if the  pad is pressed, the display will return to standby mode.

## FAN OPERATION NOTICE

At the end of Grill / Convection / Combi cooking cycles it is normal operation for the fan to continue running to cool the oven electronic system. After 5 minutes with no further cooking activity the fan will automatically shut off. However, you can begin a new cooking cycle even while the fan is running.

## STANDING TIME

"Standing time" means that after the timed cooking period ends, food should be allowed to stand either inside or outside the oven to completely finish cooking. Outside oven standing time will allow the oven to be available for other use.

## POWER LEVEL

Ten power levels are available.

Power level 0 is also available if you want to program a timed in-oven standing time.

After entering Time Cook digits and prior to starting operation, press Power Level and "PL10" will display. Adjust the power by pressing a number pad as indicated in the table below.

Level	10	9	8	7	6	5	4	3	2	1	0
Power	100%	90%	80%	70%	60%	50%	40%	30%	20%	10%	0%
Display	PL10	PL-9	PL-8	PL-7	PL-6	PL-5	PL-4	PL-3	PL-2	PL-1	PL-0

## ONE TOUCH START

(1) Instant cooking at 100% power level and 1 to 6 minutes cooking time can be started by pressing number pads 1 to 6.

(2) Instant cooking at 100% power level and 30 seconds cooking time can be started by pressing . Each repeated press will increase cooking time by 30 seconds.

The maximum cooking time is 99 minutes, 99 seconds.

Note: Time can also be added in 30 second increments by pressing  during Microwave Cooking.

## WEIGHT DEFROST FUNCTION

(1) Press **Weight Defrost**, "dEF1" and DEF. indicator "v" will appear in the display window.

Press the same pad repeatedly, "dEF1", "dEF2", "dEF3" will display in order.

LED display	dEF1	dEF2	dEF3
Food	Meat	Poultry	Fish

(2) Press number pads to enter the weight to be defrosted.

Input the weight range between 0.2 to 6.0 lbs.

The lb indicator "v" will flash in the display window.

If the weight input is not between 0.2 to 6.0 lbs, the input will be invalid. The oven will not operate until valid numbers are entered.

(3) Press  to start defrosting and the cooking time remaining will be displayed.

Note: During the Defrost cycle, the oven will beep to remind you to turn over the food. Turn over food, close door and press  to resume defrost cycle.

## AUTO COOK FUNCTION

- (1) Press Auto Cook, "Ac-1" will display.
- (2) Press Auto Cook repeatedly to choose the menu. See Auto Cook table below.
- (3) Press number pad to enter weight or portions.
- (4) Press  to start cooking.

Auto Cook Menu:

Food	Display	Weight / Portion
Potato	Ac-1	8 oz / 16 oz / 24 oz / 32 oz (1 ea / 2 ea / 3 ea / 4 ea)
Fresh Vegetable	Ac-2	4 oz / 8 oz / 12 oz / 16 oz
Frozen Vegetable	Ac-3	4 oz / 8 oz / 10 oz / 12 oz / 16 oz
Ground Meat	Ac-4	8 oz / 12 oz / 16 oz / 24 oz
Fish/Seafood	Ac-5	8 oz / 12 oz / 16 oz / 24 oz

## AUTO COOK TABLE

	Food	Serving Amount and Recommendations
1	<b>Potato</b>	Serving size is 1 to 4 medium sized potatoes, about 8 to 10 oz. (225 to 280 g) each. Pierce each potato several times with a fork and place around the edge of the oven tray, at least 1 in.(2.5cm) apart.
2	<b>Fresh Vegetable</b>	Serving size is 1 to 4 cups (250 ml to 1L). Place moist vegetables in a microwavable container. Add 2 to 4 tablespoons (30 to 60 ml) water. Cover with plastic wrap and vent*. Most vegetables need stirring and 2 to 3 minutes standing time after cooking.
3	<b>Frozen Vegetable</b>	Serving size is 1 to 4 cups (250 ml to 1L). Remove from package and place vegetables in a microwavable container. Add 2 to 4 tablespoons (30 to 60 ml) water. Cover with plastic wrap and vent*. Most vegetables need stirring and 2 to 3 minutes standing time after cooking.
4	<b>Ground Meat</b>	Serving size is 8 to 24oz. (1/2 to 1.5lbs.) Crumble meat into a microwave-safe container. Season and cover with plastic wrap. Vent cover for well-done meat. Cover dish for medium cooked meat (such as meat to be used in another dish and cooked further).
5	<b>Fish/Seafood</b>	Serving size is 8 to 24oz. (1/2 to 1.5lbs.) Place the food around the sides of a microwave-safe container. Season and add 1/4 to 1/2cup (60 to 125 ml) liquid (wine, water, salsa, etc.) if desired. Cover with plastic wrap and vent*.

\*Fold back one corner of the plastic wrap to vent excess steam.

## AUTO REHEAT FUNCTION

- (1) Press Auto Reheat, "rH-1" will display.
- (2) Press Auto Reheat repeatedly to choose the menu. See Auto Reheat table below.
- (3) Press number pad to enter weight or portions.
- (4) Press  to start cooking.

Auto Reheat Menu:

Food	Display	Weight / Portion
Dinner Plate	rH-1	10 oz / 12 oz / 16 oz
Soup/Sauce	rH-2	1 cup / 2 cups / 3 cups / 4 cups
Casserole	rH-3	1 cup / 2 cups / 3 cups / 4 cups

## AUTO REHEAT TABLE

	Food	Serving Amount and Recommendations
1	<b>Dinner Plate</b>	Serving size is about 10 to 16 oz (280 to 450 g). Place food to be heated on a dinner plate or similar dish. Cover with plastic wrap and vent*.
2	<b>Soup/Sauce</b>	Serving size is 1 to 4 cups (250 ml to 1L). Place food to be heated in a casserole dish. Cover with plastic wrap and vent*.
3	<b>Casserole</b>	Serving size is 1 to 4 cups (250 ml to 1L). Place food to be heated in a casserole dish. Cover with plastic wrap and vent*.

\*Fold back one corner of the plastic wrap to vent excess steam.



## AUTO BAKE FUNCTION

- (1) Press Auto Bake, "Ab-1" will display.
- (2) Press Auto Bake repeatedly to choose the menu. See Auto Bake table below.
- (3) Press number pad to enter weight or portions. For Ab-4, press number pad 1 through 3 to choose weight. For Ab-1, Ab-2, Ab-3, You do not need to press number pad to choose a weight or portion.
- (4) Press  to start cooking.

Auto Bake Menu:

Food	Display	Weight / Portion
Frozen Pizza	Ab-1	10~12inch thin crust frozen pizza
Muffins	Ab-2	6cup muffin (With preheat function)
Biscuit/Dinner Roll /Bread Stick	Ab-3	1 pan (With preheat function)
Frozen French Fries	Ab-4	8 oz / 12 oz / 16 oz

**CAUTION:** Do not consume foods immediately after oven finishes cooking. Heated foods, especially pizza, may burn your mouth. Allow foods to cool to a safe eating temperature.

When using the convection function, only place the grill pan on the glass tray.

## AUTO BAKE TABLE

	Food	Serving Amount and Recommendations
1	<b>Frozen Pizza</b>	For best results, a pizza pan is not required. Use a 10~12-inch thin-crust frozen pizza. If baking a rising-crust pizza, add an additional 10 to 20 minutes' baking time on convection cook at 450°F(230°C). Place the frozen pizza directly on the high rack.
2	<b>Muffins</b>	Use 1 package of a muffin mix. Place the low rack on the turntable. After PREHEAT, use 6-cup muffin pan; place pan on rack.
3	<b>Biscuit/Dinner Roll /Bread Stick</b>	For best results, bake one pan of biscuits, dinner rolls, or breadsticks at a time. After PREHEAT, place the biscuits 1-2 in. (2.5-5 cm) apart on a greased pizza pan or cookie sheet on the low rack. Cool on the rack for 10 minutes after cooking.
4	<b>Frozen French Fries</b>	Use frozen, prepared French fries. Do not overlap or layer potatoes. For crispier potatoes, use MORE to add additional cooking time. Spread the french fries on a pizza pan or cookie sheet. Place the pan on the high rack. Weight range: 8 to16 oz. (225 to 450 g).

## AUTO ROAST FUNCTION

- (1) Press Auto Roast, "Ar-1" will display.
- (2) Press Auto Roast repeatedly to choose the menu. See Auto Roast table below.
- (3) Press number pad to enter weight.
- (4) Press  to start cooking.

Food	Display	Weight / Portion
Roast Beef	Ar-1	2 lb ~ 4 lb
Roast Chicken	Ar-2	2.4 lb ~ 6 lb
Roast Pork Chop	Ar-3	1 lb ~ 4 lb
Roast Potato	Ar-4	1 lb ~ 2 lb

**CAUTION:** When using the convection function, only place the grill pan on the glass tray.

## AUTO ROAST TABLE

	Food	Serving Amount and Recommendations
1	<b>Roast Beef</b>	Weigh roast and pat dry with paper towels. Place a microwave-safe/heatproof plate on turntable to catch drippings. Place roast on low rack. After cooking, loosely tent roast beef with aluminum foil and let stand for 5 to 10 minutes. Weight range: 2 to 4 lbs. (1 to 2 kg)
2	<b>Roast Chicken</b>	Weigh whole chicken. Remove giblets and neck and discard. Thoroughly wash inside and outside of chicken with cold water. Pat chicken dry with paper towels. Secure the legs with kitchen twine. Brush outside of chicken with melted butter or margarine. Place a microwavesafe/heatproof plate on turntable to catch drippings. Place chicken breast side up on low rack. After cooking, loosely tent roast chicken with aluminum foil and let stand for 10minutes. Weight range: 2.4 to 6lbs. (1 to 3 kg)
3	<b>Roast Pork Chop</b>	Weigh roast and pat dry with paper towels. Place a microwave-safe/heatproof plate on turntable to catch drippings. Place roast on low rack. After cooking, loosely tent roast with aluminum foil and let stand for 5 to 10minutes. Weight range: 1 to 4lbs. (450g to 2 kg)
4	<b>Roast Potato</b>	Wash and dry the potatoes thoroughly. Cut potatoes into even sized pieces and season. Place potatoes in microwave-safe/heatproof plate. Place on high rack. Weight range: 1 to 2lbs. (450g to 1 kg)

## COMBINATION FUNCTION (Microwave + Convection)

- (1) Press Micro + Conv, " : 0" and MICRO and CONV indicator "v" will appear in the display window.
- (2) Press number pads 0 through 9 to choose cooking temperature. Temperature selections (°F):  
0 = 425, 1=100, 2 = 200, 3 = 250, 4 = 275, 5 = 300, 6 = 325, 7 = 350  
8 = 375, 9 = 400. MICRO and CONV Indicator "v", "F" and the corresponding temperature will display.
- (3) Press number pads to enter the cooking time. The maximum cooking time is 99 minutes, 99 seconds.
- (4) Press  to start cooking. The remaining cook time will display. You can check the selected temperature by pressing MICRO + CONV during cooking.

Note: When using the convection function, you should place grill pan on the glass tray.

## GRILL FUNCTION (Grill)

- (1) Press Grill, " : 0" and GRILL indicator "v" will appear in the display window.
- (2) Press number pads to enter the cooking time; the maximum cooking time is 99 minutes and 99 seconds.
- (3) Press  to start cooking.

## CONVECTION COOK

- (1) Press Conv, " : 0" and CONV indicator "v" will appear in the display window.
- (2) Press number pads 0 through 9 to select cooking temperature if desired. Temperature selections (°F):  
0 = 425, 1=100, 2 = 200, 3 = 250, 4 = 275, 5 = 300, 6 = 325, 7 = 350  
8 = 375, 9 = 400. "Conv", "F" and the corresponding temperature will display.
- (3) Press  to start preheating. Selected temperature, "F" and "PrEH" are alternately displayed. CONV indicator "v" will display, and PREH indicator "v" will flash. When the oven preheats to the selected cooking temperature, PREH indicator "v" stops flashing and the oven will beep to remind you, and selected temperature, "F" will flash in the display to remind you to place food in oven and set the cook time. If no cook time is entered within 15 minutes, the oven will return to display " : 0" or the clock time.

Note: Grill Pan - Only for use with Convection cooking. Only place grill pan on glass tray.  
will return to display the clock time.

- (4) Press number pads to enter the cooking time. The maximum cooking time is 99 minutes, 99 seconds.
- (5) Press  to start cooking. The remaining cook time will display. "Conv" will display and you can check selected temperature by pressing CONV during cooking.

Note: 1) If no preheat is needed, follow step 1 and 2 above and then skip to step 4.

2) If preheating, do not place food into oven until cooking temperature is reached.

3) If Convection Cooking without preheating, place food into oven at the start of cooking.

4) When using the convection function, only place grill pan on the glass tray.

# ONE TOUCH COOK

## POPCORN

(1) Press Popcorn repeatedly until the number you wish appears in the display, "3.2", "3.0", "1.75" will appear in the display in order.

Press Once: Popcorn 3.2 oz

Press Twice: Popcorn 3.0 oz

Press 3 Times: Popcorn 1.75 oz

(2) Press  to start cooking. Cook time for size chosen appears in the display. Oven beeps 3 times when cooking is finished.

## BEVERAGE

(1) Press Beverage repeatedly until the number you wish appears in the display, "1", "2", "3" cup will display in order.

(2) Press  to start cooking. Cook time for number chosen appears in the display. Oven beeps 3 times when cooking is finished.

Food	Amount	Comments
Popcorn	1.75oz. 3.0oz. 3.2oz.	Use only with prepackaged microwave popcorn weighing 1.75, 3.0,3.2 ounces. Do not use this feature twice in succession on the same food portion –it may result in severely overcooked or burnt food.
Beverage (200ml/1cup)	1 cup 2cups 3cups	Do not cover. Drinks heated with the Beverage feature may be very hot. Remove the container with care. Do not use this feature twice in succession on the same food portion –it may result in severely overcooked or burnt food.

## MULTI-STAGE COOKING

At most 2 stages can be set for cooking.

Note: **ONE TOUCH COOK**, **ONE TOUCH START** and **SENSOR COOK** cannot be used in multi-stage cooking.

Example: 80% Power Level for 5 minutes followed by 60% Power Level for 10 minutes;

- a. Press **Time Cook** once, then press "5", "0" and "0" to set first stage cook time.
- b. Press **Power Level** once, then press "8" to choose 80% first stage cooking power.
- c. Press **Time Cook** again, then press "1", "0", "0" and "0" to set second stage cook time.
- d. Press **Power Level** again, then press "6" to choose 60% second stage cooking power.
- e. Press  to immediately start multi-stage cooking.

## LOCK FUNCTION

To lock the microwave so that it cannot be operated by children or other unintended users, press  pad for 3 seconds. You will hear a long beep and "Loc" and LOCK indicator "v" will appear in the display window.

To Unlock, press  for 3 seconds, You will hear a long beep and the LOCK indicator "v" will disappear in the display window.

## COOKING END REMINDER FUNCTION

The oven will beep 3 times to alert the user that cooking time has ended. "End" will display.

The time of day will display by opening the door or pressing  pad.

**WARNING** - If you see arcing, press **STOP/CLEAR** pad and correct the problem.

Arcing is the microwave term for sparks in the oven. Arcing is caused by :

- a) Metal or foil touching the side of the oven.
- b) Foil not molded to food (upturned edges act like antennas).
- c) Metal such as twist-ties, poultry pins, or gold rimmed dishes in the microwave.
- d) Recycled paper towels containing small metal pieces being used in the microwave.

# Maintenance

## Troubleshooting

Check your problem by using the chart below and try the solutions for each problem. If the microwave oven still does not work properly, contact the following number for customer assistance: 1-800-657-6119.

TROUBLE	POSSIBLE CAUSE	POSSIBLE REMEDY
Oven will not start	<ul style="list-style-type: none"> <li>a. Electrical cord for oven is not plugged in.</li> <li>b. Door is open.</li> <li>c. Wrong operation is set.</li> </ul>	<ul style="list-style-type: none"> <li>a. Plug into the outlet.</li> <li>b. Close the door and try again.</li> <li>c. Check instructions.</li> </ul>
Arcing or sparking	<ul style="list-style-type: none"> <li>a. Materials to be avoided in microwave oven were used.</li> <li>b. The oven is operated when empty.</li> <li>c. Spilled food remains in the cavity.</li> </ul>	<ul style="list-style-type: none"> <li>a. Use microwave-safe cookware only.</li> <li>b. Do not operate with oven empty.</li> <li>c. Clean cavity with wet towel.</li> </ul>
Unevenly cooked foods	<ul style="list-style-type: none"> <li>a. Materials to be avoided in microwave oven were used.</li> <li>b. Food is not defrosted completely.</li> <li>c. Cooking time, power level is not suitable.</li> <li>d. Food is not turned or stirred.</li> </ul>	<ul style="list-style-type: none"> <li>a. Use microwave-safe cookware only.</li> <li>b. Completely defrost food.</li> <li>c. Use correct cooking time, power level.</li> <li>d. Turn or stir food.</li> </ul>
Overcooked foods	Cooking time, power level is not suitable.	Use correct cooking time, power level.
Undercooked foods	<ul style="list-style-type: none"> <li>a. Materials to be avoided in microwave oven were used.</li> <li>b. Food is not defrosted completely.</li> <li>c. Oven vents are blocked or restricted.</li> <li>d. Cooking time, power level is not suitable.</li> </ul>	<ul style="list-style-type: none"> <li>a. Use microwave-safe cookware only.</li> <li>b. Completely defrost food.</li> <li>c. Check to see that oven ventilation ports are not restricted.</li> <li>d. Use correct cooking time, power level.</li> </ul>
Improper defrosting	<ul style="list-style-type: none"> <li>a. Materials to be avoided in microwave oven were used.</li> <li>b. Cooking time, power level is not suitable.</li> <li>c. Food is not turned or stirred.</li> </ul>	<ul style="list-style-type: none"> <li>a. Use microwave-safe cookware only.</li> <li>b. Use correct cooking time, power level.</li> <li>c. Turn or stir food.</li> </ul>
Sensor cooked foods not properly cooked	<ul style="list-style-type: none"> <li>a. Cover or lid on food not vented.</li> <li>b. Door opened before sensor detected cooking time appears in display.</li> </ul>	<ul style="list-style-type: none"> <li>a. Cover or lid over food must contain vent hole for escaping steam.</li> <li>b. Do not open door to stir or turn food before sensor detected cooking time appears in display.</li> </ul>

## **KENMORE LIMITED WARRANTY**

**FOR ONE YEAR** from the date of sale this appliance is warranted against defects in material or workmanship when it is correctly installed, operated and maintained according to all supplied instructions.

**WITH PROOF OF SALE** a defective appliance will be replaced free of charge. For warranty coverage details to obtain free replacement, visit the web page: [www.kenmore.com/warranty](http://www.kenmore.com/warranty)

This warranty does not cover the oven cavity light bulb, which is an expendable part that can wear out from normal use within the warranty period.

This warranty is void if this appliance is ever used for other than private household purposes.

This warranty gives you specific legal rights, and you may also have other rights which vary from state to state.

Sears Brands Management Corporation, Hoffman Estates, IL 60179

## **GARANTÍA LIMITADA DE KENMORE**

**DURANTE UN AÑO** a partir de la fecha de venta, este electrodoméstico, posee garantía contra defectos en los materiales o en la mano de obra cuando se instale, opere y mantenga correctamente de acuerdo con todas las instrucciones provistas.

**CON EL COMPROBANTE DE VENTA**, un electrodoméstico defectuoso será reemplazado gratuitamente.

Para ver los detalles de cobertura de la garantía a fin de obtener un reemplazo gratis, visite la página web:

[www.kenmore.com/warranty](http://www.kenmore.com/warranty)

Esta garantía no cubre la bombilla dentro del horno, que es una pieza consumible que se puede desgastar con el uso normal dentro del periodo de garantía.

Esta garantía se anula si este electrodoméstico se usa para cualquier propósito que no sea el uso doméstico privado.

Esta garantía le otorga derechos legales específicos, y es posible que tenga también otros derechos, los cuales varían de un estado a otro.

Sears Brands Management Corporation, Hoffman Estates, IL 60179



# ABOUT THIS MANUAL

(주) 신광씨링

광주광역시 서구 하남대로

502번길 14

담 당	김지수 님		
브 랜 드	Kenmore	언 어	영어
F.MODEL	Kenmore KOC15 모델 사용자 매뉴얼		
B.MODEL	111,71519810 – Black / Negro 111,71513810 – Stainless Steel / Acero Inoxidable		
B U Y E R			
COUNTRY			
M E M O	총 23p (140 x 210)		
18.07.17-1p (7p _ 일러스트 그림 하 작업 2 cut ) 18.07.24-총 23p (1~23p _ ① 신규 작업, ② 일러스트 호환 작업 1 cut) 18.07.26-7p (4p, 5p, 9p, 12p, 17p, 18p, 19p) 18.08.06-4p (1p, 7p, 9p, 16p) 18.08.08-1p (1p)			

**NO NEED PRINT**