

# DAEWOO

# Microwave Oven

MODEL: KOT-170U/KOT-170S/KOT-174S

Use and Care  
Manual

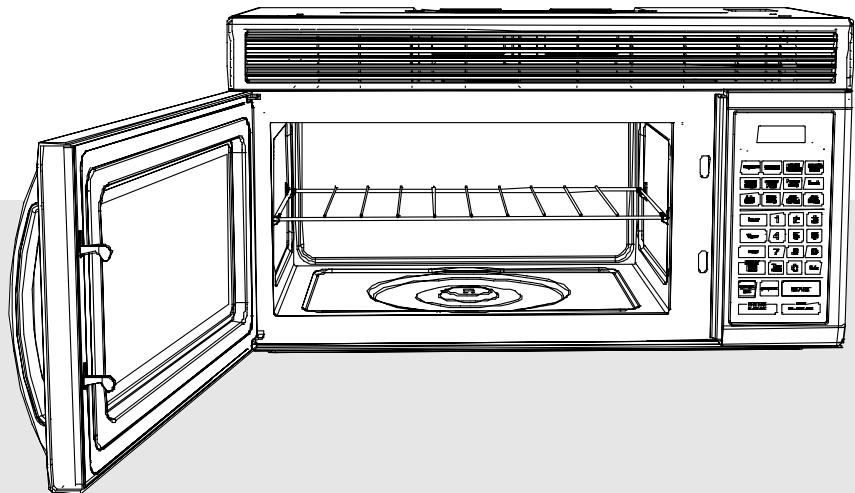

## Table of Contents

Help us help you  
Important Safety Information  
Operating Instruction, Tips  
Cooking Guide  
Care and Cleaning

# IMPORTANT-SAFETY INSTRUCTIONS 1

Read all instructions before using this appliance.

## PRECAUTIONS TO AVOID POSSIBLE EXPOSURE TO EXCESSIVE MICROWAVE ENERGY

(a) **Do Not Attempt** to operate this oven with the door open since open-door operation can result in harmful exposure to microwave energy. It is important not to defeat or tamper with the safety interlocks.

(b) **Do Not Place** any object between the oven front face and the door or allow soil or cleaner residue to accumulate on sealing surface.

(c) **Do Not Operate** the oven if it is damaged. It is particularly important that the oven door close properly and that there is no damage to the:

- (1) door (bent)
- (2) hinges and latches (broken or loosened)
- (3) door seals and sealing surface.

(d) **The Oven Should Not** be adjusted or repaired by anyone except properly qualified service personnel.

When using electrical appliances, basic safety precautions should be followed, including the following:

**WARNING** - To reduce the risk of burns, electric shock, fire, injury to persons or exposure to excessive microwave energy:

\* **Read and follow** the specific "Precautions to Avoid Possible Exposure to Excessive Microwave Energy" above.

\* **This appliance must be grounded.** Connect only to properly grounded outlet. See Grounding Instructions section.

\* **Use this appliance only for its intended use as described in this manual.** Do not use corrosive chemicals or vapors in this appliance. This microwave oven is specifically designed to heat or cook food, and is not intended for laboratory or industrial use.

\* **This over-the-range oven was designed for use over ranges no wider than 30 inches.** It may be installed over both gas and electric cooking equipment.

\* **For best operation, plug this appliance into its own electrical outlet, to prevent flickering of lights, blowing of fuse or tripping of circuit breaker.**

\* **Do not mount this appliance over a sink. Install or locate this appliance only in accordance with the provided Installation Instructions.**

\* **Do not cover or block any openings on the appliance.**

\* **Do not store this appliance outdoors.** Do not use this product near water—for example, in a wet basement, near a swimming pool or near a sink.

\* **Do not store anything directly on top of the microwave oven surface when the oven is in operation.**

\* **Do not immerse power cord or plug in water.**

\* **Keep power cord away from heated surfaces.**

This ISM apparatus meets all requirements of the Canadian Interference Causing Equipment Regulations.

# IMPORTANT-SAFETY INSTRUCTIONS 2

(continued)

- \* **Do not let power cord hang over edge of table or counter.**
  - \* **Do not operate this appliance if it has a damaged power cord or plug, if it is not working properly, or if it has been damaged or dropped.**
  - \* See door surface cleaning instructions in the Card and Cleaning section of your book.
  - \* **This appliance should be serviced only by qualified service personnel.** Contact nearest authorized service facility for examination, repair or adjustment.
  - \* **As with any appliance, close supervision is necessary when used by children.**
- 
- \* **To reduce the risk of fire in the oven cavity:**
    - Do not overcook food.** Care fully attend appliance if paper, plastic or other combustible materials are placed inside the oven to facilitate cooking.
    - \* **Remove wire twist-ties from paper or plastic bags before placing bags in oven.**
    - \* **Do not use your microwave oven to dry newspapers.**
    - \* **Do not use recycled paper products.** Recycled paper towels, napkins and waxed paper can contain metal flecks which may cause arcing or ignite. Paper products containing nylon or nylon filaments should be avoided, as they may also ignite.
    - \* **Do not pop popcorn in your microwave oven** unless in a special microwave popcorn accessory or unless you use popcorn labeled for use in microwave ovens.
    - \* **Do not overcook potatoes.** They could dehydrate and catch fire, causing damage to your oven.
  - \* **Do not operate the oven in microwave while empty to avoid damage to the oven and the danger of fire.** If by accident the oven should run empty a minute or two, no harm is done. However, try to avoid operating the oven empty at all times-it saves energy and prolongs the life of the oven.
  - \* **Do not use the oven for storage purposes. Do not leave paper products, cooking utensils or food in the oven when not in use.**
  - \* **If materials inside oven should ignite,** keep oven door closed, turn oven off, and disconnect power cord, or shut off power at the fuse or circuit breaker panel.
- 
- \* **Oversized food or oversized metal cookware should not be used in a microwave oven because they increase the risk of electric shock and could cause a fire.**
  - \* **Do not clean with metal scouring pads.** Pieces can burn off the pad and touch electrical parts involving risk of electric shock.
  - \* **Do not store any materials, other than our recommended accessories, in this oven when not in use.**
  - \* **Don't defrost frozen beverages** in narrow necked bottles (especially carbonated beverages).  
Even if the container is opened, pressure can build up. This can cause the container to burst, possibly resulting in injury.
  - \* **Use metal only as directed in this book.** TV dinners may be microwaved in foil trays less than 3/4" high; remove top foil cover and return tray to the box. When using metal in the microwave oven, **keep metal (other than metal shelf) at least 1 inch away from sides of the oven.**

# IMPORTANT-SAFETY INSTRUCTIONS 3

(continued)

\* **Do not cover the shelf or any other part of the oven with metal foil. This will cause overheating of the microwave oven.**

\* **Cookware may become hot** because of heat transferred from the heated food. Pot holders may be needed to handle the cookware.



\* **Sometimes, the oven floor and walls can become too hot to touch.** Be careful touching the floor and walls during and after cooking.

\* **Foods cooked in liquids** (such as pasta) may tend to boil over more rapidly than foods containing less moisture. Should this occur, refer to the Care and Cleaning section(s) for instructions on how to clean the inside of the oven.

\* **Thermometer** - Do not use a thermometer in food you are microwaving unless the thermometer is designed or recommended for use in the microwave oven.

\* **Plastic cookware** - Plastic cookware designed for microwave cooking is very useful, but should be used carefully. Even microwave-safe plastic may not be as tolerant of overcooking conditions as are Glass or ceramic materials and may soften or char if subjected to short periods of overcooking. In longer exposures to overcooking, the food and cookware could ignite. For these reasons: 1) Use microwave-safe plastics only and use them in strict compliance with the cookware manufacturer's recommendations. 2) Do not subject empty cookware to microwaving. 3) Do not permit children to use plastic cookware without complete supervision.

\* **When cooking pork**, follow the directions

exactly and always cook the meat to an internal temperature of at least 170°F. This assures that in the remote possibility that trichina may be present in the meat, it will be killed and meat will be safe to eat.

\* **Do not boil eggs in a microwave oven.** Pressure will build up inside egg yolk and will cause it to burst possibly resulting in injury.

\* **Foods with unbroken outer "skin"** such as potatoes, sausages, tomatoes, apples, chicken livers and other giblets, and egg yolks (see previous caution) should be pierced to allow steam to escape during cooking.



\* **Not all plastic wrap is suitable for use in microwave ovens.**

Check the package for proper use.



\* **Spontaneous boiling** - Under certain special circumstances, liquids may start to boil during or shortly after

removal from the microwave oven. To prevent burns from splashing liquid, stir the liquid briefly before removing the container from the microwave oven.

\* **Some products such as whole eggs and sealed containers** - for example, closed glass jars - will explode and should not be heated in this microwave oven. Such use of the microwave oven could result in injury.

\* **Avoid heating baby food** in glass jars, even without their lids; especially meat and mixtures.

# IMPORTANT-SAFETY INSTRUCTIONS 4

(continued)

\* **“Boilable” cooking pouches and tightly closed plastic bags** should be slit, pierced or vented as directed by package. If they are not, plastic could burst during or immediately after cooking, possibly resulting in injury. Also, plastic storage containers should be at least partially uncovered because they form a tight seal. When cooking with containers tightly covered with plastic wrap, remove covering carefully and direct steam away from hands and face.



popcorn bags, cooking Pouches and boxes. To prevent possible injury, direct steam away from hands and face.

\* **Hot foods and steam can cause burns.** Be careful when opening any containers of hot food, including

**heat settings.** Boilover causes smoking and greasy spillovers that may ignite and spread if fan operation, use adequate sized cookware and use high heat only when necessary.

- **In the event of a grease fire,** smother flaming pan on surface unit by covering pan completely with well-fitting-lid, cookie sheet or flat tray.



- **Clean the vent hood often.** Do not allow grease to build up on the hood or the filter.

- **Use care when cleaning the vent hood filter.** Corrosive cleaning agents, such as lye-based oven cleaners, may damage the filter.

- **When flaming foods under the hood, turn the fan off.** The fan, if operating, may spread the flame.

## The Exhaust Hood

\* **Have it installed and properly grounded by a qualified installer. See the special installation booklet packed with the microwave oven.**

\* **The exhaust fan in the oven will operate automatically under certain conditions (see Automatic Fan Feature). While the fan is operating, caution is required to prevent the starting and spreading of accidental cooking fires while the exhaust fan is in use. For this reason:**

- **Never leave surface units unattended at high**

## SAVE THESE INSTRUCTIONS

### Optional Accessories

Available at extra cost from your DAEWOO supplier.

**Charcoal filter Kit (351190030)** for non-vented installation.

---

## VARIABLE POWER LEVELS (1-10)

5

Variable power levels add flexibility to your microwave cooking. The power levels on your microwave oven can be compared to the surface units on a range. High (power level 10) or full power is the fastway to cook and gives you 100% power.

each power level gives you microwave energy a certain percent of the time. Power Level 7 is microwave energy 70% of the time. Power Level 3 is microwave energy 30% of the time.

A high setting (10) will cook faster but may need additional attention such as frequent stirring, rotating or turning over. Most of your cooking will be done on HIGH (Power Level 10). A lower setting will cook more evenly and with less attention given to stirring or rotating the food. Some foods may have better flavor, texture or appearance if one of the lower setting is used. You

may wish to use a lower power level when cooking foods that have a tendency to boil over, such as scalded potatoes.

Reset periods (when the microwave energy cycles off) give time for the food to “equalize” or transfer heat to the inside of the food. An example of this is shown with Power Level 3 - the defrost cycle. If microwave energy did not cycle off, the outside of the food would cook before the inside was defrosted.

Here are some examples of uses for various power levels:

---

## AUTOMATIC FAN FEATURE

Cooking appliance installed under the oven may, under some heavy usage conditions. Cause temperatures high enough to overheat some internal parts of the microwave oven.

To prevent overheating from taking place, the exhaust fan is designed to automatically turn on at a low speed if excessive temperatures occur. Should this happen, the fan cannot be manually turned off, but it will automatically turn off when the internal parts have cooled. The fan may stay on up to approximately 30 minutes after the range and microwave oven controls have been turned off.

---

---

# YOUR TOUCH CONTROL PANEL

# 6

The Touch Control Panel allows you to set the oven controls with the touch of a finger. It's designed to be easy to use and understand.

- 1. DISPLAY WINDOW** - Displays time of day, time or temperature during cooking functions, power level being used, cooking mode and instructions.
  - 2. POPCORN** - Touch this pad to cook prepackaged microwave popcorn weighing 1.75 or 3.5 ounces. The oven will start automatically.
  - 3. BEVERAGE** - Touch this pad to reheat a beverage. The oven will start automatically.
  - 4. FROZEN VEGETABLE** - Touch this pad to cook frozen vegetables. The oven will start automatically.
  - 5. FAVORITE CHOICE** - Touch this pad to recall three cooking instructions placed in memory and to program sound level of signals, scroll speed and disable clock display.
  - 6. BAKED POTATO** - Touch this pad to cook 1-4 potatoes. The oven will start automatically.
  - 7. DINNER PLATE** - Touch this pad to reheat a dinner plate full of chilled leftovers.
  - 8. FROZEN PIZZA** - Touch this pad to heat frozen pizza. The oven will start automatically.
  - 9. SNACK** - Touch this pad to warm a variety of snack foods by means of the automatically preset microwave power and cook time.
  - 10. SENSOR COOK (KOT-170S, 174S)** - will automatically compute the microwave power and cook time. Refer to Sensor Cook Guide.
  - 11. AUTO COOK (KOT-170U)** - Will automatically set the microwave power and cook time. Refer to Auto Cook Guide.
  - 12. COOK TIME** - Microwave for a selected amount of time.
    - Power Level 10 (High) is automatic but lower heat levels may be programmed.
  - 13. AUTO DEFROST** - Touch this pad and enter food weight, then START. The oven automatically sets power levels and defrosting time.
  - 14. ADD MINUTE** - Touch this pad for 1 minute of cook time, to add 1 minute of cook time as the timer is counting down or for an "instant on" for 1 minute.
  - 15. POWER** - Touch this pad if you want to change from automatic Power Level 10 (High) for cooking.
  - 16. NUMBER PADS** - Touch these pads to enter cooking time, defrosting time, time of day, power level or food weights for Auto Defrost.
  - 17. WARM** - Touch this pad and safely keep food warm for up to 30 minutes.
  - 18. TIMER (Kitchen timer)** - This feature uses no micro-wave energy. It functions as either a kitchen timer, as a holding period after defrost or as a delay timer before time cooking.
  - 19. DISPLAY (Multi-Language)** - Touch this pad to select the user's language.
  - 20. TURN TABLE** - Touch this pad to turn the turntable on and off.
  - 21. HELP** - Touch this pad if you want to know the feature of key pad on the control panel.
  - 22. CANCEL/OFF (Stop/Clear)** - When touched once, it pauses the oven operation. When touched twice, it shuts off the oven and erases all setting (except time of day).
  - 23. CLOCK** - Touch this pad to enter time of day or check time of day while microwaving.
  - 24. START** - After all selections are made, touch this pad to start the oven or timer.
  - 25. VENT FAN** - Touch this pad to select the speed of vent fan or to turn the vent fan on or off.
  - 26. LIGHT** - Touch this pad to turn on or off the surface light and night light.
-

&lt; KOT-170U &gt;

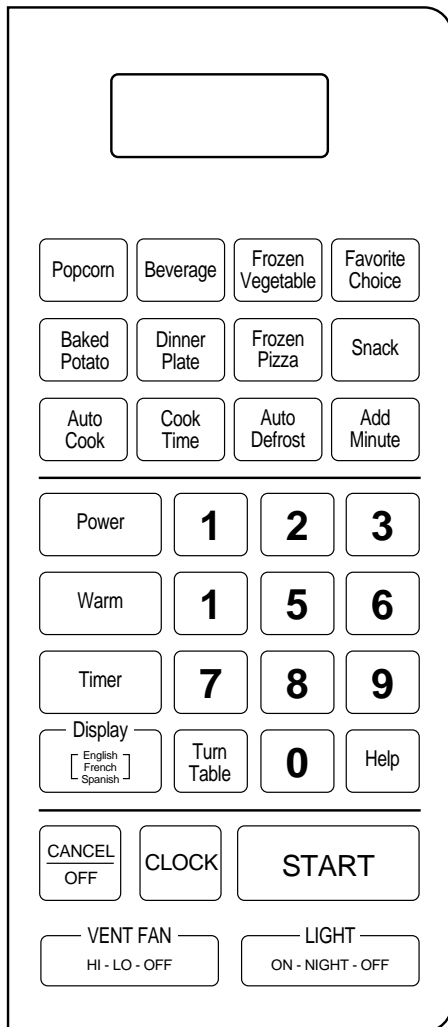

&lt; KOT-170S/174S &gt;

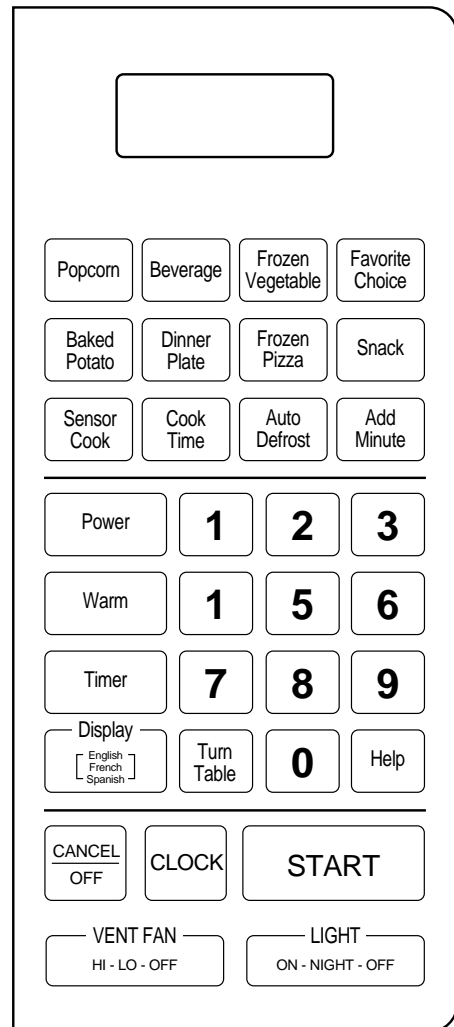

## When You Plug in the Oven

After plugging in the oven, the display will scroll "TOUCH CLOCK PAD TO ENTER TIME OF DAY."

If power is disrupted at any time, the above sequence recurs.



---

# FEATURES OF YOUR OVEN

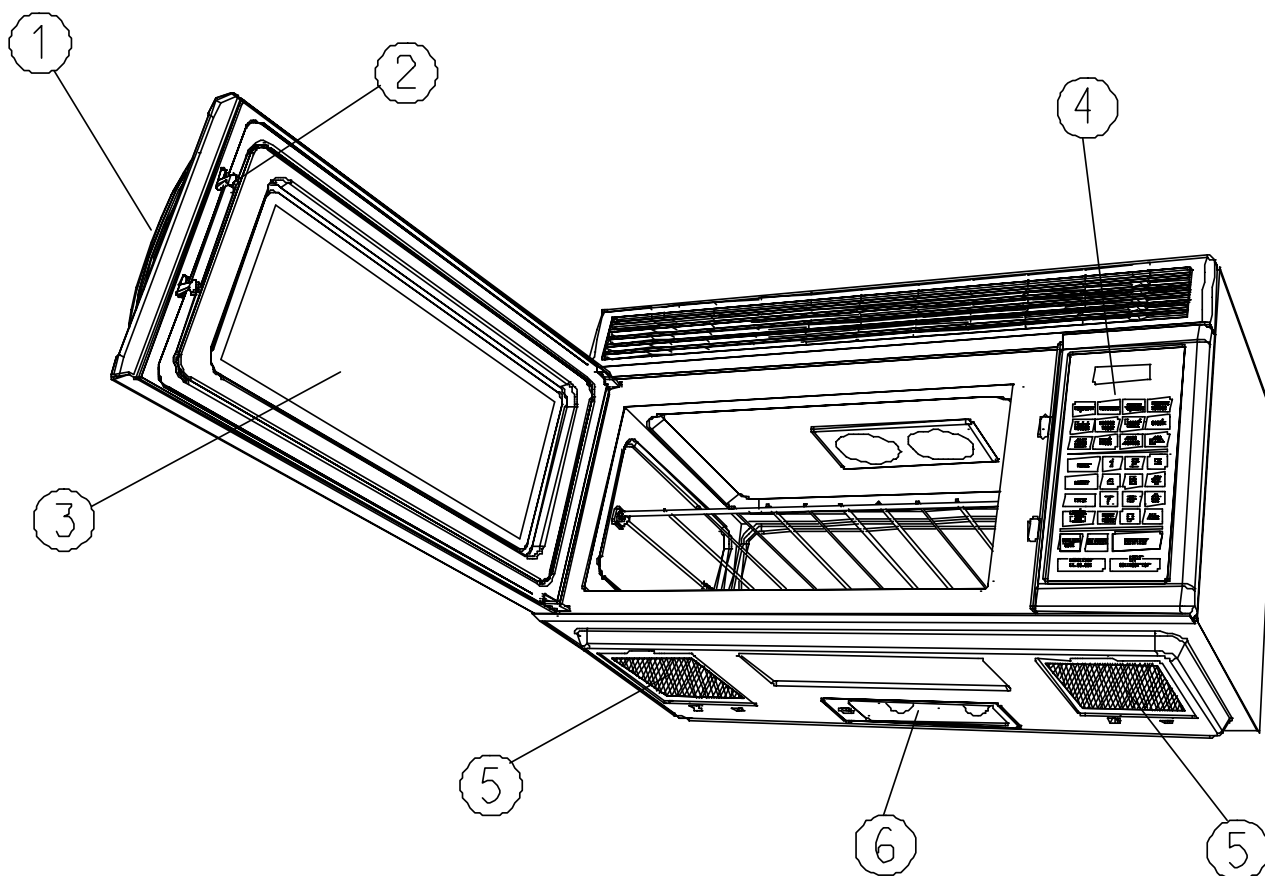

- 
1. **Door Handle.** Pull to open door. Door must be securely latched for oven to operate.
  2. **Door Latches.**
  3. **Window with metal shield.** Screen allows cooking to be viewed while keeping microwaves confined in oven.
  4. **Touch Control Panel and Digital Display.**

For detailed information on each feature, see your touch Control Panel section.

5. **Grease Filters.**
6. **Cooktop Light.**

**NOTE:** oven vent(s) and oven light are located on the inside walls of the microwave oven.

---

---

# HOW TO SET THE OVEN CONTROLS

**This section includes useful information about oven operation.**

1. Plug power supply cord into standard 3-pronged 15 Amp, 120V AC 60Hz power outlet socket.
2. After placing the food in a suitable container, open the oven door and put it on the glass tray. The glass tray must always be in place during cooking.
3. Shut the door. Make sure that it is firmly closed.

---

1. When the oven door is opened, the light turn off.

2. The oven door can be opened at any time during operation. The oven will automatically shut off. To restart the oven, close the door and then touch START.

3. Each time a pad is touched, a BEEF will sound to acknowledge the touch. One of the function pads must be touched before the number pads.

Therefore, no beep will sound if the number pad is touched before the function pad.

4. The oven automatically cooks on full power unless set to a lower power level.

5. The display will SCROLL "TOUCH CLOCK PAD TO ENTER TIME OF DAY" when the oven is

plugged in.

6. If set, the time of day will always be displayed when no other cooking function is being used.

7. When the CANCEL/OFF pad is touched during the oven operation the oven stops cooking and all information is retained. To erase all information (except the present time and memory data), touch the CANCEL/OFF pad once more. If the oven door is opened during the oven operation, all information is retained.

8. If the START pad is touched and the oven does not operate, check the area between the door and door seal for obstructions and make sure the door is closed securely. The oven will not start cooking until the door is completely closed or the program has been reset.

**Make sure the oven is properly installed and plugged into the electrical outlet.**

---

## Wattage output chart

The power-level is set by pressing the POWER pad. The chart shows the display, the power level and the percentage of power.

Touch Power pad, Once the touch	Powr Level (Display)	Approximate Percentage of Power
Power	P-HI	100%
9	P-90	90%
8	P-80	80%
7	P-70	70%
6	P-60	60%
5	P-50	50%
4	P-40	40%
3	P-30	30%
2	P-20	20%
1	P-10	10%
0	P-0	0%

---

## ***Time-of-Day Clock***

### Basic Instructions

1. Touch the **CLOCK Pad**. “LOCK ENTER TIME” will be displayed.
2. Set the time of day by touching the appropriate numbers. The selected time appears and “PRESS CLOCK AGAIN” will be displayed.
3. Touch the **CLOCK Pad** again. The colon will flash.

- After plugging in the oven or after a power outage, the **Display** will scroll “TOUCH CLOCK PAD TO ENTER TIME OF DAY”. Touch the **CANCEL/OFF Pad** and set the clock following the directions above.
- The “time-of-day” clock is a 12 hour clock.
- If set, the time of day will always be displayed when no other cooking function is being used.
- The time of day returns to the current time when the oven turns off.

---

## ***Cook Time/Power Level***

### Basic Instructions

1. Touch the **COOK TIME Pad**. “ENTER COOKING TIME” will be displayed.
2. Enter the cooking time by using the number pads. For example, for 5 minutes touch number 5, 0, 0.  
The selected time and “PRESS START” will be displayed.
3. Touch the **START Pad**. “COOK TIME” and selected time will be displayed.
  - The cooking time will appear in the **Display Window**.
  - The oven will start cooking and time countdown will begin.
  - The oven will stop automatically when the time is done and beep three times.
  - When the cook time ends, “END COOK” appears in the **Display**.

- Start with the shortest recommended time and add more time as needed.
  - Check the food as it cooks.
  - The oven door can be opened any time during operation. It will automatically stop and maintain the time setting until the door is closed and the **START Pad** is touched again.
  - If the **START Pad** is touched and the oven does not operate, check the area between the door and door seal for obstructions. The oven will not start until the door is completely closed.  
Seal for obstructions. The oven will not start until the door is completely closed.
  - **Note:** Full power is automatic. If you wish to use a different power level, touch the **POWER Pad** before touching **START Pad**. “POWER LEVEL IS HI [10] TOUCH 1-9 FOR NEW POWER LEVEL---PRESS START” will be displayed. Enter the power level desired by touching the appropriate number pad. The selected power level and “PRESS START” will be displayed.
-

## Power Level Cooking Guide

The power levels on your microwave oven can be compared to the surface units on a range. HIGH (power level 10) or full power is the fastest way to cook and gives you 100% power.

Each power level gives you microwave energy for a certain percent of time, for example, power level 7 is microwave energy 70% of the time. Most of your cooking will be done on HIGH (Power Level 10). A lower setting will cook more evenly and with less attention given to stirring or rotating the food. Some foods may have better flavor, texture or appearance if one of the lower settings is used. You may wish to use a lower power level when cooking foods that have a tendency to boil over, such as scalloped potatoes. Cooking times will increase as the power level decreases.

Power Level	Best Uses
High 10	Fish, bacon, vegetables, boiling liquids
Medium 7	Gentle cooking of meat and poultry, baking casseroles and reheating
Medium 5	Slow cooking and tenderizing for stews and less tender cuts of meat.
Low 3	Defrosting, simmering, delicate sauces.
Warm 1	Keeping food warm without overcooking, softening butter.

## Two Stage Cooking

This feature lets you program two sequential operations such as defrosting and cooking or cooking

using two different power levels. It automatically changes power settings and cooking time.

### Basic Instructions

1. Touch the **COOK TIME Pad**. "ENTER COOKING TIME" will be displayed.
2. Touch the appropriate number pads to enter the cooking time. The selected time and "PRESS START" will be displayed.
3. Touch the **POWER Pad**.\* "POWER LEVEL IS HI[10]. TOUCH 1-9 FOR NEW POWER LEVEL--PRESS START" will be displayed.
4. Touch the number pad for the power level you desire.\* The selected power level and "PRESS START" will be displayed.
5. Touch the **COOK TIME Pad** again. "ENTER SECOND COOKING TIME" will be displayed.
6. Touch the appropriate number pads to enter the cooking time for the second stage of cooking. The selected time and "PRESS START" will be displayed.
7. Touch the **POWER Pad**.\* "POWER LEVEL IS HI[10]. TOUCH 1-9 FOR NEW POWR LEVEL PRESS START" will be displayed.
8. Touch the number pad for the power level you desire.\* The selected power level and "PRESS START" will be displayed.
9. Touch the **START Pad**.

- Three beeps signal the end of cooking. "END COOK" appears in the **Display**.
- The audible beep between stages can serve as a reminder to add foods or ingredients.

\* Skip steps 3 and 4 or 7 and 8 if full power is desired.

## Auto Defrost

Use the defrost setting for defrosting meats, poultry and fish from .5 pounds to 6.5 pounds.

### Basic Instructions

- Touch the **AUTO DEFROST Pad** once for meat. "MEAT DEFROST ENTER FOOD WEIGHT IN LBS" will be displayed.
  - Touch the **AUTO DEFROST Pad** twice for poultry. "POULTRY DEFROST ENTER FOOD WEIGHT IN LBS" will be displayed.
  - Touch the **AUTO DEFROST Pad** three times for fish. "FISH DEFROST ENTER FOOD WEIGHT IN LBS" will be displayed.
- Touch number pads to enter the weight.\* The defrosting time and power levels are automatically calculated.
  - Touch the **START Pad**. "DEFROST TIME" and time appear in the **Display**.

\* Enter the weight in pounds and tenths of a pound. See Conversion Chart below.

- During defrosting, the oven will beep a series of short beeps to signal that the food needs to be turned or rearranged. "TURN FOOD OVER" will be displayed. Oven will continue operating if food is not turned or rearranged. Three beeps signal the end of defrosting. "END DEFROST" appears in the **Display**.

### Conversion Chart

If weight is in ounces-	then weight is converted to tenths-of-a-pound.
1 to 2-oz.	0.1
3 to 4-oz.	0.2
5-oz.	0.3
6 to 7-oz.	0.4
8-oz.	0.5
9 to 10-oz.	0.6
11 to 12-oz.	0.7
13-oz.	0.8
14 to 15-oz.	0.9

## Defrosting by Time

### Basic Instructions

- Touch the **COOK TIME Pad**. "ENTER COOKING TIME" will be displayed.
- Enter the defrosting time desired.
- Touch the **POWER Pad**. "POWER LEVEL IS HI[10]" will be displayed.
- Touch **NUMBER "3" Pad**. "PL-30 PRESS START" will be displayed.
- Touch the **START Pad**.

- Three short beeps indicate an incorrect entry.
- See defrosting tips for both Auto and Time Defrost.

### General Defrosting Tips

- Do not defrost covered meat. Covering might allow cooking to take place. Always remove outer wrap and tray. Place food on a microwave-safe rack in a dish. During defrost, juices accumulate in dish and may become hot enough to cook the food. Elevating meat off of the dish will prevent the bottom and sides from beginning to cook.
- Begin defrosting whole poultry breast-side-down. Begin defrosting roasts fat-side down.
- The shape of the package alters the defrosting time. Shallow rectangular shapes defrost more quickly than a deep block.
- Auto Defrost** is programmed for specific weights. Defrost results will be affected if you enter an incorrect weight.

5. Auto Defrost is programmed for frozen food at 0°F. If food is stored at a higher temperature, expect shorter defrost times.
6. After 1/3 of the defrost time has elapsed, check the food. You may wish to turn over, break apart, rearrange or remove thawed portions of the food.
7. **During Auto Defrost, the oven will prompt you to turn the food over.** At this point, open oven door and check the food. Follow the techniques listed below for optimum defrost results. Then, close oven door, the touch Start Pad to complete defrosting.
  - **Turn Over:** Roast, ribs, whole poultry, turkey breasts, hot dogs, sausages, steaks, or chops.
  - **Rearrange:** Break apart or separate steaks, chops, hamburger patties, ground meat, chicken or seafood pieces, chunks of meat such as stew beef.
  - **Shield:** Use small strips of aluminum foil to protect thin areas or edges of unevenly shaped foods such as chicken wings. To prevent arcing, do not allow foil to come within 1-inch of oven walls or door.
  - **Remove:** To prevent cooking, thawed portions should be removed from the oven at this point. This may shorten defrost time for foods weighing less than 3-lbs.
8. After defrosting, allow food to stand 5 to 10 minutes if there are any icy areas. If large solid roasts, such as sirloin tip or rump roasts, are not completely thawed after standing, return roast to oven and program **Auto Defrost** for 1 lb.

### Defrost by Time Guide (Power Level 3)

Items and Weight	Defrosting Time	Standing Time	Procedures and Techniques
<b>Beef</b>			
Ground Beef/1 lb.	10-12 min.	5 min.	Break apart and remove thawed portions with fork Break apart and remove thawed portions with fork Turn over part way. Shield ends or thinner areas with foil. Separate and rearrange once.
Ground Beef/2 lb.	18-20 min.	8-12 min.	
Beef Roast, boneless/3 lbs.	26-28 min.	7-10 min.	
Steaks/1" thick	7-8 min.	5-7 min.	
<b>Pork</b>			
Pork Roast, boneless/3 lbs.	26-28 min.	10-15 min.	Turn over part way. Shield ends or thinner areas with foil. Separate and rearrange once. Break apart and remove thawed portions with fork. Turn meat over and rearrange, separate once.
Pork Chops/1 lb.	7-8 min.	5-7 min.	
Ground Pork/1 lb.	10-12 min.	5-7 min.	
Spareribs/12 lbs.	15-16 min.	5-7 min.	
<b>Poultry</b>			
Whole Chicken/3 lbs.	20-22 min.	10-15 min.	Turn chicken over. Shield wing tips, leg ends and breast areas with foil. Breast side down. Separate and rearrange once. Separate and rearrange once.
Chicken Breasts boneless/1 lb.	7-8 min.	5-7 min.	
Chicken Thighs/2 lbs.	18-23 min.	8-13 min.	
<b>Fish</b>			
Fish Fillets/1 lb.	10-11 min.	5-7 min.	Separate and rearrange once. Shield as needed.

## Auto Start

The AUTO START feature allows you to program your oven to begin cooking at a preset time of day—up to a delay of 11 hours and 59 minutes. You can program two sequential operations using two different power levels.

### Basic Instructions

1. Touch the **COOK TIME Pad**.
2. Enter the cooking time.\*
3. Touch the **POWER Pad**.
4. Enter the power level.
5. Touch the **COOK TIME Pad**.
6. Enter cooking time.
7. Touch the **POWER Pad**.
8. Enter the power level.
9. Touch the **CLOCK Pad**.
10. Enter the clock time you want the oven to start.
11. Touch the **START Pad**\*\*

\* To cook with only one Stage, omit steps 5, 6, 7 & 8.

\*\* The oven will start cooking at the set time. If the door is opened before the start time is reached, touch the **START Pad** to resume the **AUTO START** option.

- The **AUTO START** feature cannot be used with the following options: **POPCORN, FROZEN PIZZA, BEVERAGE, FROZEN VEGETABLE, DINNER PLATE, BAKED POTATO, WARM, ADD MINUTE, TIMER, FAVORITE CHOICE, AUTO DEFROST, SNACK, AUTO COOK** and **SENSOR COOK**.
- Do not use foods containing baking powder or yeast when using **AUTO START**. They will not rise properly.
- **Warning:** Do not use foods that will spoil while waiting for cooking to start, such as dishes with milk or eggs, cream soups and cooked meats or fish. Any food that has to wait for cooking to start should be very cold or frozen before it is put in the oven. Unfrozen foods should never stand more than two hours before cooking starts.

Do not allow food to remain in the oven for more

### To Check Auto Start Time:

Touch the **CLOCK Pad**. The programmed **AUTO START** time and “**AUTO START COOKING TIME---**” will appear in the **Display**.

### Tips on Setting Auto Start:

- Before setting, check that the correct time of day is displayed.
- If you hear the fan start when you touch the **START Pad**, you have not set the oven properly. Touch the **CANCEL/OFF Pad** and start over.

### More or Less Time Adjustment

You may increase or decrease any of the pre-set settings for the **ONE TOUCH COOKING FEATURES** except the **SNACK** feature if you prefer more or less cooking time.

### To Adjust the Pre-set Settings:

1. Touch the **POWER Pad** once to decrease the time by 20 seconds or twice to increase the time by 20 seconds.
2. Touch the desired **ONE TOUCH COOKING Pad**.

### Add Minute

The ADD MINUTE Pad provides a convenient way to heat foods at full power with one touch of a pad or add an extra minute to your cooking cycle when in progress. The microwave starts automatically after the pad is touched.

Basic Instructions  
 1. Touch the **ADD MINUTE Pad**. The **Display** will show "PRESS AGAIN TO ADD MIN".

**ADD MINUTE** cannot be used with **ONE TOUCH COOKING FUNCTIONS, SENSOR COOK, AUTO COOK, AUTO DEFROST, TIMER, FAVORITE CHOICE** or **WARM**.

Each time the pad is touched the oven will add 1 minute to the time up to 99 minutes.

### Timer

Basic Instructions  
 1. Touch the **TIMER Pad**. The **Display** will show "ENTER TIME".  
 2. Enter desired time. The **Display** will show the selected time and "PRESS START".  
 3. Touch the **START Pad**. The **Display** will show "TIMER" and selected time.

- The timer can be programmed up to 99 minutes and 99 seconds.
- Three beeps signal the end of the timing operation.
- To stop the timer once it has started, touch the **CANCEL/OFF Pad** twice. Display will return to the time of day or cooking program.
- The timer cannot be set while cooking.
- The door must be shut for the timer to operate.

### Auto Cook (KOT-170U ONLY)

Basic Instructions  
 1. Touch the **AUTO COOK Pad** until the desired food is displayed.\*  
 2. Touch the number pad indicated on the Cooking Guide for the cooking weight desired.\*  
 3. Touch the **START Pad**.

- \* See the following chart or the Cooking Guide Label on the front of the oven cavity.
- Auto Cook has preset times and power levels for four food categories: Soup, Fresh Vegetables, Muffins and Fresh Fish Fillets.
  - The Display counts down the cooking time.

#### Cooking Tips and Techniques

- For best results, cover container with plastic wrap and turn back one edge of the wrap to form a 1/2-inch slot where steam can escape.
- After cooking fresh vegetables, allow 3-5 minutes of stand time before serving. This will allow the food to finish cooking without overcooking.
- When preparing fresh vegetables, add 1/2 cup of water per 1/2 pound of fresh vegetables.

### Auto Cook Guide

FOOD	TOUCH AUTO COOK PAD	NUMBER PAD	QUANTITY
1. Soup	Once	1	8 oz.
		2	16 oz.
		3	24 oz.
		4	32 oz.
2. Fresh Vegetables	Twice	1	4 oz.
		2	8 oz.
		3	12 oz.
		4	16 oz.
3. Muffins	Three Times	1	2 ea.
		2	4 ea.
		3	6 ea.
		4	8 ea.
4. Fresh Fish Fillets	Four Times	1	4 oz.
		2	8 oz.
		3	12 oz.
		4	16 oz.



**Sensor Cook (KOT-170S, KOT-174S ONLY)**

SENSOR COOK will automatically customize the cook time for food in four categories - soup, fresh vegetables, muffins and fish fillets.

- Basic Instructions
1. Touch the **SENSOR COOK** Pad until the desired food is displayed.\*
  2. Touch the **START** Pad.

\* Note: See the following chart or the Cooking Guide Label on the front of the oven cavity.

**Cooking Tips and Techniques**

- For best results, cover container with plastic wrap and turn back one edge of the wrap to form a 1/2-inch slot where steam can escape.
- After cooking fresh vegetables, allow 3-5 minutes of stand time before serving. This will allow the food to finish cooking without overcooking.

- When preparing fresh vegetables, add 1/2 cup of water per 1/2 pound of fresh vegetables.

**Sensor Cook Guide**

FOOD	TOUCH SENSOR COOK PAD	DISPLAY GUIDE	QUANTITY
1. Soup	Once	"SOUP PRESS START"	8-32 oz.
2. Fresh Vegetables	Twice		4-16 oz.
3. Muffins	Three Times	"MUFFIN--PRESS START"	2-8 ea.
4. Fish Fillets	Four Times	"FISH--PRESS START"	4-16 oz.

**Oven shelf (KOT-170S, KOT-174S ONLY)**

The oven shelf will give you extra space when cooking with more than one container at the same time.

**INSERTING THE OVEN SHELF**

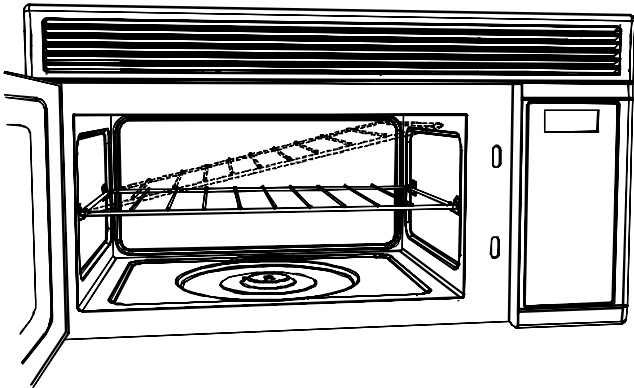

- \* Do not cook with the shelf on the microwave floor. This could damage the microwave.
- \* Do not use microwave browning dish on the shelf.

The shelf could over heat.

- \* Use pot holders when handing the shelf-it may be hot.
- \* Do not use the shelf when cooking popcorn.

---

## ONE TOUCH COOKING

One touch cooking allows you to cook or reheat many of your favorite foods by touching just one pad. To increase quantity, touch chosen pad unit number in display is same as desired quantity to cook.

---

### **Popcorn**

#### Basic Instructions

1. Touch the **POPCORN Pad** once for 3.5 oz. package. The **Display** will show “3.50 OZ BAG POPCORN” or
  2. Touch the **POPCORN Pad** twice for 1.75 oz. package. The **Display** will show “1.75 OZ BAG OF POPCORN”.
- The **POPCORN Pad** has been automatically set for the correct cook time for a 3.5 oz. or 1.75 oz. bag of popcorn.
  - Listen as the popcorn pops and stop the microwave when the popping slows down to 3 seconds apart.
  - Do not try to repop unpopped kernels or reuse a bag.
  - Pop only on package at a time.

**CAUTION:** If prepackaged popcorn is a different weight than the recommended weight, do not use the **POPCORN Pad**. Inadequate popping or a fire may occur. Follow manufacturer’s instructions.

---

### **Frozen Pizza**

#### Basic Instructions

1. Touch the **FROZEN PIZZA Pad**. The **Display** will show “PIZZA”.
- The programmed time (3:00) will show in the **Display**.
  - Time set is for 6.0 - 7.5 oz. pizzas.
  - Cook only one pizza at a time.
  - Follow manufacturer’s directions.
  - Use only frozen pizza labeled microwaveable.
  - If cheese pizza does not melt sufficiently, cook a few seconds longer.

### **Beverage**

#### Basic Instructions

1. Touch the **BEVERAGE Pad** once for 1 cup (7 oz.)/mug. The **Display** will show “1 CUP”.
  2. Touch the **BEVERAGE Pad** twice for 2 cups (14 oz.)/mugs. The **Display** will show “2 CUPS”.
  3. Touch the **BEVERAGE Pad** three times for 3 cups (21 oz.)/mugs. The **Display** will show “3 CUPS”.
- NOTE:** 1. This setting is good for restoring cooled beverage to a better drinking temperature.  
2. Stir after cooking.
-

## ***Dinner Plate***

### Basic Instructions

1. Touch the **DINNER PLATE Pad**. The **Display** will show "DINNER PLATE"

- The programmed time (3:00) will show in the **Display**.

- Place meat and dense vegetables to the outside of the plate.
- Place delicate foods in the center of the plate.
- Cover the plate with wax paper to hold steam around most foods except rare meats or vegetables with crisp exteriors.

## ***Baked Potato***

### Basic Instructions

1. Touch the **BAKED POTATO Pad**:

- Once for 1 medium potato (7 oz.)
- Twice for 2 medium potatoes (14 oz.)
- Three times for 3 medium potatoes (21 oz.)
- Four times for 4 medium potatoes (28 oz.)

- The **Display** will show "1 EA POTATO", "2 EA POTATO", "3 EA POTATO" or "4 EA POTATO"

## ***Warm***

### Basic Instructions

1. Touch the **WARM Pad**. The display will show "WARM PRESS START".  
2. Touch the **START Pad**.

- The microwave oven will safely keep cooked foods warm for up to 30 minutes.
- Opening the door or touching the **CANCEL/OFF Pad** cancels the WARM setting.
- Foods that were covered during cooking should be covered during warming.
- Complete meals on a dinner plate should be covered.

## ***Frozen Vegetable***

### Basic Instructions

1. Touch the **FROZEN VEGETABLE Pad** once for 8 oz. frozen vegetable. The **Display** will show "8 OZ FROZEN VEGETABLE".  
2. Touch the **FROZEN VEGETABLE Pad** twice for 10 oz. frozen vegetable. The **Display** will show "10 OZ FROZEN VEGETABLE".

3. Touch the **FROZEN VEGETABLE Pad** three times for 16 oz. frozen vegetable. The **Display** will show "16 OZ FROZEN VEGETABLE".  
4. Touch the **FROZEN VEGETABLE Pad** four times for 20 oz. frozen vegetable. The **Display** will show "20 OZ FROZEN VEGETABLE".

**Snack**

Basic Instructions  
 1. Touch the **SNACK Pad** until the desired food is displayed.\*  
 2. Touch the number pad indicated on the Cooking Guide for the cooking weight desired.\*  
 3. Touch the **START Pad**.

\* See the following chart or the Cooking Guide Label on the front of the oven cavity.

- The **SNACK** feature automatically sets the microwaving times and power levels to warm a variety of snack foods.
- The **DISPLAY** counts down the cooking time.

**Sensor Cook Guide**

FOOD TYPE	SNACK PAD	NUMBER PAD	QUANTITY OR WEIGHT
1. Bread	Once	1	1 EA
		2	2 EA
		3	3 EA
		4	4 EA
2. Sandwich	Twice	1	1 EA
		2	2 EA
3. Dessert Topping	Three Times	1	1 EA
		2	2 EA
		3	3 EA
		4	4 EA
4. Cheese Dip	Four Times	1	7 oz.
		2	11 oz.
		3	15oz.
		4	19 oz.

**CHILD SAFETY LOCK**

The safety lock prevents unwanted oven operation such as by small children.

To set, press CANCEL/OFF for 3 seconds, the display shows “LOCKED” and the oven beeps.

To cancel, press CANCEL/OFF for 3 seconds, “LOCKED” disappears from the display and the oven beeps.

**TURNTABLE ON/OFF**

For best cooking results, leave “TURNTABLE ON/OFF” feature “ON”. When using larger microwave safe dishes it can be turned “OFF”.

- Press the TURNTABLE (ON/OFF) pad to turn feature “ON” or “OFF”.
- Display will show “TURNTABLE ON or OFF”.

**Display**

Basic Instructions  
 1. Touch the **DISPLAY Pad** until the user’s language is selected.  
 2. Touch the **START Pad**.

- This feature provide you with three languages which are used for showing you menu, instructions, cooking guides and any other terms of microwaving cooking in the display window. You can select one of the languages; English, French, Spanish.

**HELP**

Basic Instructions  
 1. Touch the **HELP Pad**.  
 2. Touch the Pad which has the function you want to know.

- The **HELP** feature show you the brief function guide for the selected key pad.

---

## Using the Vent Fan

You can control the 2-speed fan by touching the **VENT FAN Pad**.

### Basic Instructions

- Touch the **VENT FAN Pad** once for HIGH speed. The **Display** will scroll “HIGH VENT FAN”.
- Touch the **VENT FAN Pad** twice for LOW speed. The **Display** will scroll “LOW VENT FAN”.
- Touch the **VENT FAN Pad** three times for turning vent fan off. The **Display** will scroll “HIGH VENT FAN”.

**NOTE:** If the temperature gets too hot around the microwave oven, the exhaust fan in the vent hood will automatically turn on at LOW speed to protect the microwave oven against danger. The vent fan may operate until the temperature falls down less than a proper temperature around the microwave oven. When this occurs, you can not turn the vent fan off by touching the **VENT FAN Pad**.

---

### To set fan to run for a specific time:

1. Operate the vent fan by touching the **VENT FAN Pad**.
2. Program the running time.
  - Touch the **TIMER Pad** and hold for 3 seconds. The **Display** will show “FAN”.

**NOTE:** If both the fan and light are operating and the **TIMER Pad** is touched and hold, both the fan and light will be controlled by the timer.

The **Display** will alternate between “FAN” and “LIGHT” one time.

3. Enter desired time.
4. Touch the **START pad**.

---

### To cancel the operation of timer:

- Touch the **CANCEL/OFF Pad** twice.

**NOTE:** If you cancel the operation of timer, the timer is shut off only. Though you cancel the operation of timer, you cannot stop the operation of the vent fan. The vent fan will continue to operate until you turn it off.

---

---

## Using the Cooktop Light

You can control the cooktop light by touching the LIGHT Pad.

### Basic Instructions

- Touch the **LIGHT Pad** once for turning the cooktop light on.  
The **Display** will scroll “ON LIGHT”.
- Touch the **LIGHT Pad** twice for turning the night light on.  
The **Display** will scroll “NIGHT LIGHT”.
- Touch the **LIGHT Pad** three times for turning the cooktop light or night light off.  
The **Display** will scroll “OFF LIGHT”.

---

### To set the cooktop light to be on for a specific time:

1. Turn on the cooktop light or the night light by touching the **LIGHT Pad**.
  - Touch the **TIMER Pad** and hold for 3 seconds.  
The **Display** will show “LIGHT”.

**NOTE:** If both the fan and light are operating and the **TIMER Pad** is touched and hold, both the fan and light will be controlled by the timer.

The **Display** will alternate between “FAN” and “LIGHT” one time.

3. Enter desired time
4. Touch the **START Pad**.

---

### To cancel the operation of timer:

- Touch the **CANCEL/OFF Pad** twice.

**NOTE:** If you cancel the operation of timer, the timer is shut off only. Though you cancel the operation of timer, you cannot turn the light off. The light will continue to turn on until you turn it off.

---

## USING FAVORITE CHOICE

FAVORITE CHOICE allow you to recall one cooking instruction previously placed in memory and begin cooking quickly.

For example, if you heat a roll every morning, program the cooking steps into FAVORITE CHOICE. You can heat your roll each morning by touching FAVORITE CHOICE. FAVORITE CHOICE also allows you to program a function for another person to cook at a later time.

**NOTE:** You can reprogram FAVORITE CHOICE by repeating the instructions below. A power failure will erase your personal choice program.

### ***Favorite Choice***

#### ***To Program Favorite Choice Setting:***

1. Touch the **COOK TIME Pad**. Set cooking time.
2. Touch the **POWER Pad**.
3. Enter power level. Example "5" for 50% power level.
4. Touch the **FAVORITE CHOICE Pad**.
5. Touch the **CANCEL/OFF Pad** to place in memory.

When a program has been entered, "MEMO" will appear in the Display to let you know that the program has been entered.

• **NOTE:** Repeat steps 1-5 for FAVORITE CHOICE Programs 2 and 3.

#### ***To Change Favorite Choice Setting:***

- Touch and hold the **FAVORITE CHOICE Pad** for 3 seconds or until a beep sounds. Display shows "PROG-1". Previously set information will be erased.
- Follow previous steps 1-5 to program new settings.

#### ***To Use Favorite Choice:***

1. Put food in oven and close door.
2. Touch the **FAVORITE CHOICE Pad**. "PROG 1" will appear in the display.
- To select program 2 or 3 press the **FAVORITE CHOICE Pad** until desired program number appears in the display.

3. Touch the **START Pad**.

#### ***To Program Favorite Choice Signal Sound, Scroll Speed and Clock Display:***

Touch the **FAVORITE CHOICE Pad** four times "PROG-4 SELECT TYPE ENTER 1-6" will be displayed.

#### ***To Change Signal Sound:***

- Touch number pad 1. "BUZZER ON" will be displayed. Touch **CANCEL/OFF pad**.
- Touch number "2" pad. "BUZZER OFF" and "MUTE" will be displayed. "MUTE" will remain in the **Display** until the buzzer is turned on. Touch **CANCEL/OFF Pad**.

#### ***To Change Scroll Speed:***

- Touch number "3" pad. "FAST SCROLL SPEED" will be displayed. Touch **CANCEL/OFF Pad**.
- Touch number "4" pad. "NORMAL SCROLL SPEED" will be displayed. Touch **CANCEL/OFF Pad**.
- Touch number "5" pad. "SLOW SCROLL SPEED" will be displayed. Touch the **CANCEL/OFF Pad**.

#### ***To Turn Clock Display On/Off:***

- Touch number "6" pad. Signal will sound and the **Display** will go blank. To recall the time of day, touch the **START Pad** and the current time of day will be displayed for 10 seconds.

**Keep your oven clean and sweet smelling.** Opening the door a few minutes after cooking helps air out the inside. An occasional through wiping a solution of baking soda and water keeps the inside fresh.

**Don't use sharp-edged utensils on your oven.** The inside and outside oven walls can be scratched. The control panel can be damaged.

**BE CERTAIN POWER IS OFF BEFORE CLEANING ANY PART OF THIS OVEN.**

---

## How to Clean the Inside

**Wall and floor.** some spatters can be removed with a paper towel, others may require a damp cloth. Remove greasy spatters with a sudsy cloth, then rinse with a damp cloth. Do not use abrasive cleaners on oven walls. **NEVER USE A COMMERCIAL OVEN CLEANER ON ANY PART OF YOUR MICROWAVE OVEN.**

**Door (inside). window:** Wipe up spatters daily and wash when soiled with a damp cloth. Rinse thoroughly and dry.

Metal and plastic parts on door: Wipe frequently with a damp cloth to remove all soil. **DO NOT USE ABRASIVES, SUCH AS CLEANING POWDERS OR STEEL AND PLASTIC PADS. THEY WILL DAMAGE THE SURFACE.**

---

## How to Clean the Outside

**Case.** Clean the outside of your oven with soap and damp cloth, rinse with a damp cloth and then dry. Wipe the window clean with a damp cloth.

Chrome trim is best wiped with a damp cloth and then with a dry towel.

**Control Panel.** Wipe with a damp cloth. Dry thoroughly. **DO not use cleaning sprays, large amounts of soap and water, abrasive or sharp objects on the panel-they can damage it.**

**Door Surface.** When cleaning surfaces of the door and oven that come together on closing door, use only mild, non-abrasive soaps or detergents applied with a sponge or soft cloth.

**Power Cord.** If the cord becomes soiled, unplug and wash with a damp cloth. For stubborn spots, sudsy water may be used, but be certain to rinse with a damp cloth and dry thoroughly before plugging cord into outlet.

---



---

# THE EXHAUST FEATURE

**The exhaust hood** feature on your microwave oven is equipped with two metal filters which collect grease. When the fan is operated, air is drawn up through the filters and is then discharged through the provide venting to the outside.

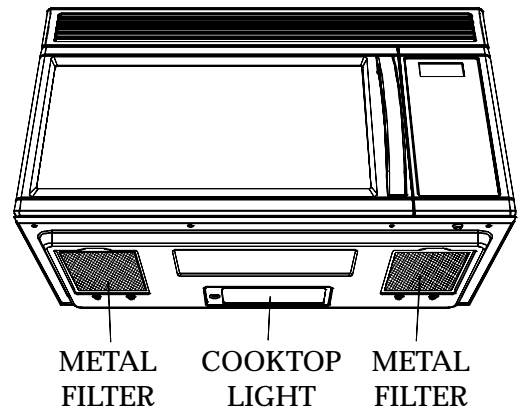

---

## Reusable grease filter

**The grease filters should be cleaned at least once a month.** Never operate the microwave without the filters in place. In situations where flaming might occur on surfaces below hood, filters will stop the entry of flames into the unit.

### To Remove Grease Filter

**To remove grease Filter,** grasp the “finger hold” on the filter and slide to the rear. Then pull filter downward and to the front. The filter will drop out.

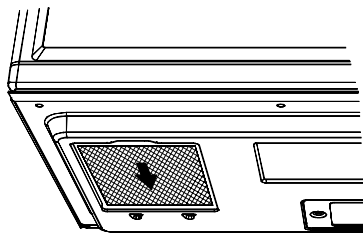

### To Clean and Replace grease Filter

**To clean grease filters, soak it and then agitate filter in solution of hot water and detergent.** Don't use ammonia or ammonia products because they will darken the metal. Light brushing can be used to remove embedded dirt. Rinse, shake and remove moisture before replacing.

**To replace grease Filter,** slide the filter in the frame slot on the back of the opening. Pull filter upward and to the front to lock into place.

---

---

# GROUNDING INSTRUCTION

25

This appliance must be grounded. In the event of an electrical short circuit, grounding reduces the risk of electric shock by providing an escape wire for the electric current. This appliance is equipped with a power cord having a grounding wire with a grounding plug. The plug must be plugged into an outlet that is properly installed and grounded.

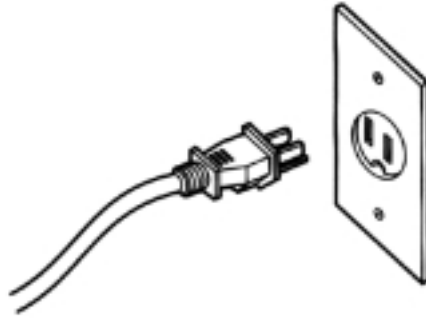

electrician or service technician if the grounding instructions are not completely understood, or if doubt exists as to whether the appliance is properly grounded.

Where standard two-prong wall receptacle is encountered, it is

your personal responsibility and obligation to have it replaced with a properly grounded three-prong wall receptacle. A short power-supply cord is provided to reduce the risks resulting from becoming entangled in or tripping over a longer cord.

**Do not under any circumstance cut or remove the third (ground) prong from the power cord. Do not use an adapter plug with this appliance. Do not use an extension cord with this appliance.**

## **WARNING-**

Improper use of the grounding plug can result in a risk of electric shock. Consult qualified

---

### **Power supply cord**

- a) A short power-supply cord is provided to reduce the risks resulting from becoming entangled in or tripping over a longer cord.
  - b) Longer cord sets or extension cord are available and may be used if care is exercised in their use.
  - c) If a long cord or extension cord is used:
    - 1) The marked electrical rating of the cord set or extension cord should be at least as great as the electrical rating of the appliance.
    - 2) The extension cord must be a grounding type 3-wire cord, and
    - 3) The longer cord should be arranged so that it will not drape over the counter top or tabletop where it can be pulled on by children or tripped over unintentionally.
-

## Cooktop Light

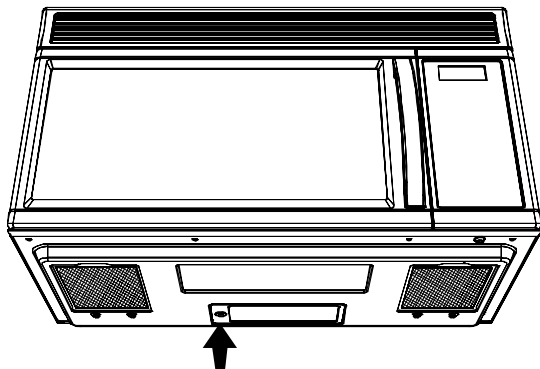

**To replace** the combination cooktop light/night light, first **disconnect power at main fuse or circuit breaker panel or pull plug**. Remove screw on right side of light compartment cover and lower cover until it stops.

Be sure bulbs to be replaced are cool before removing. Break-the adhesive seat by gently

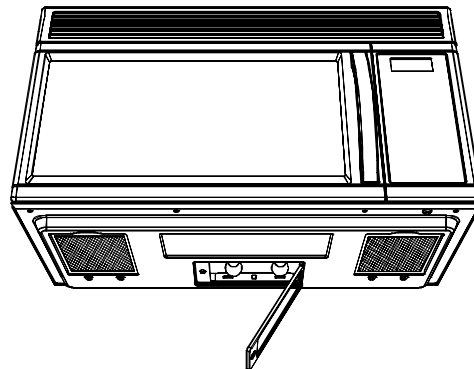

unscrewing the bulbs. Replace with 30 watt incandescent bulbs available from your supplier.

High intensity 30-watt bulbs, which are available in supermarkets and hardware stores, may also be use for replacement. Raise light compartment cover and replace screw.

Connect electrical power to microwave oven.

---

## Oven Light

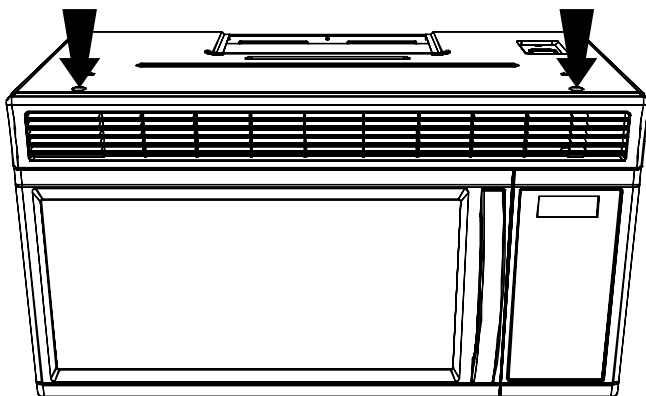

**To replace** your oven light, first **disconnect power at main fuse or circuit breaker panel or pull plug**. Remove the top grill by taking out the 2 screws that hold it in place.

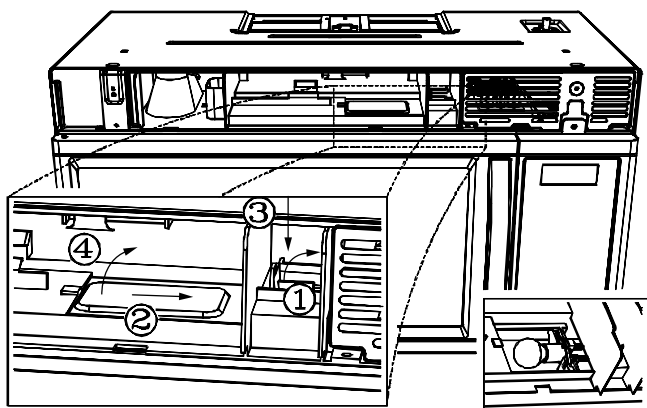

Remove the charcoal filter and pull out the lamp cover. Replace the burned-out bulb with a 30-watt bulb.

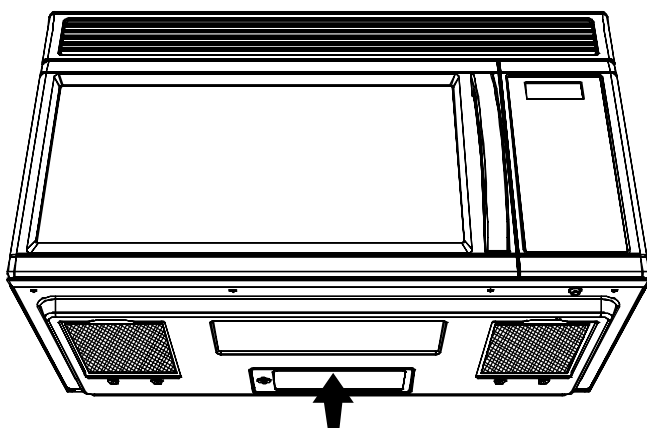

**Clean** off the grease and dust on hood surfaces often. Use a solution of warm water and detergent. About 1 tablespoon of ammonia may be added to the water. Take care not to touch the filters and enamel surfaces with this solution; ammonia will drain metal.

# SPECIFICATIONS

Power supply	120V Volts AC 60Hz Only
Power consumption	1700 W, Max.
Microwave output power	1100 W (IEC 705)
Microwave frequency	2,450 MHz $\pm$ 50MHz
Outside dimensions (WxHxD)	760x427x383 mm (29.9x16.8x15.0 in.)
Cavity dimensions (WxHxD)	506x256x363 mm (19.9x10.0x14.2 in.)
Cavity volume	1.7 Cu. Ft.
Weight (Net.Cross)	Approx. 25Kg (55.1 lbs.)/31 Kg (68.3 lbs.)
Timer	Digital. 99 minutes 99 seconds

\* Specifications subject to change without notice.

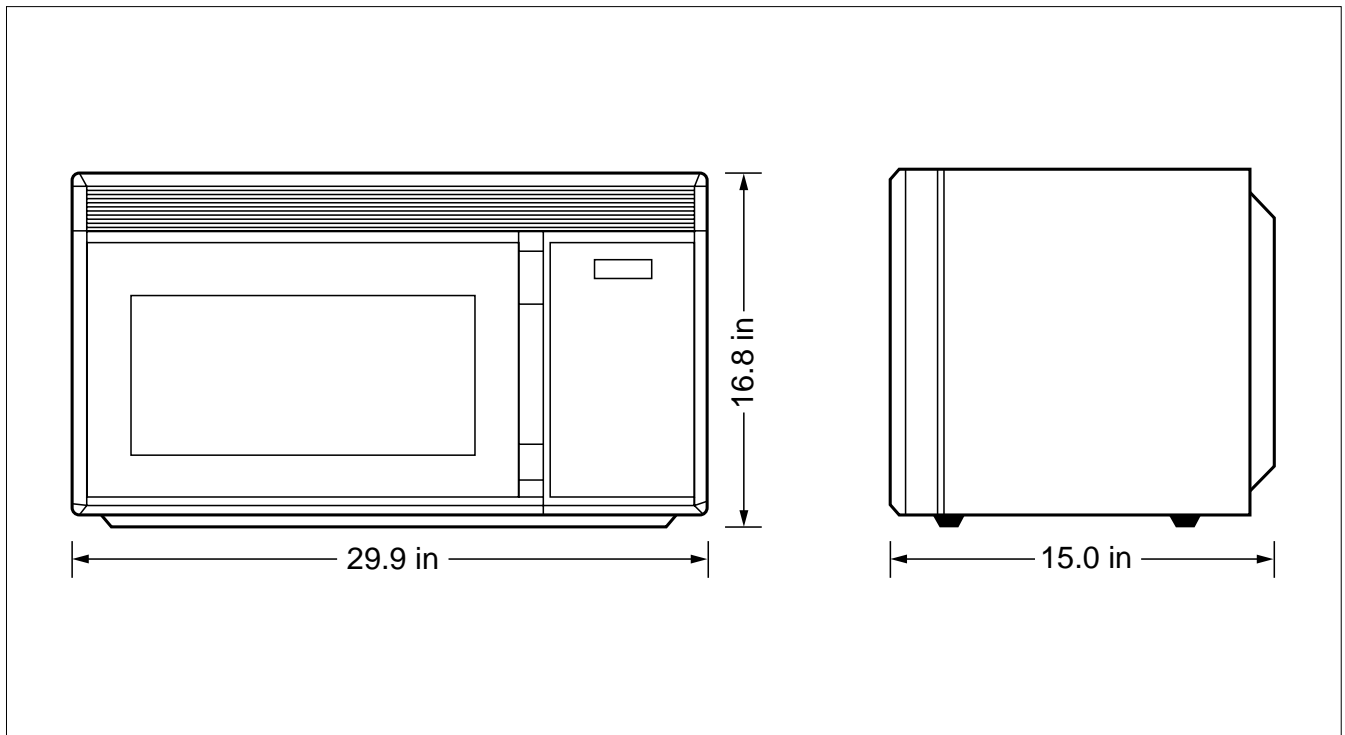

# MICROWAVE OVEN WARRANTY

Daewoo Electronics Corporation of America ( DECA) warrants this product to be free from defects in material and workmanship and agrees to remedy any such defect. This warranty covers 2 years labour and 2 years parts, plus an additional 3 years part warranty on magnetron only, from the date of original purchase. This warranty applies only to product purchased from an authorized DECA dealer and used within the boundaries of America. This warranty does not apply to removal and reinstallation, filters, product that has been improperly installed, subjected to usage for which the product was not designed, misused or abused, damaged during transportation, or which has been altered or repaired in any way that affects the reliability or detracts from its performance.

## How to Obtain Warranty Service

Warranty service can only be provided by an authorized DECA Service centre. For the closest authorized Service centre to you, please contact your Dealer. In order to receive warranty service you must provide the authorized Service centre with a copy of proof of purchase, signifying the date of purchase and the name of the Dealer from whom you purchased the product.

## Statutory Warranties

The purchaser may have rights under existing provincial or federal laws, and where any terms of this warranty are prohibited by such laws, they are deemed null and void, but the remainder of the warranty shall remain in effect.

If you require further assistance, you may contact us at:

Daewoo Electronics Corporation of America  
120 CHBB Avenue,  
Lyndhurst, New Jersey,  
U.S.A.  
Tel: