

WizFi310 UART WiFi Module Specification V1.0

WiZnet Co.,Ltd

main8096@wiznet.co.kr

© 2015 WiZnet all rights reserved.

Mentioned in this document , the actual company and product names, trademarks are their respective owners.

After update the new version, this document without prior notice.

Content

- 1. General Description..... 1
- 2. Features.....2
- 3. System Block Diagram..... 4
- 4. Module Hardware Description.....5
 - 4.1 Module photo..... 5
 - 4.2 Package information..... 5
 - 4.3 Pin definition.....6
 - 4.4 Reference design..... 7
- 5. Electrical Specification..... 8
 - 5.1 General specification.....8
 - 5.2 802.11b Mode..... 8
 - 5.3 802. 11g Mode.....9
 - 5.4 802. 11n HT20 Mode.....9
 - 5.5 802. 11n HT40 Mode.....10
- 6. Order information..... 11
 - 6.1 Order part number..... 11
 - 6.2 Module size..... 11
- 7. Contact information.....12
- 8. Modification records..... 12

1. General Description

WizFi310 module is a Wi-Fi module that fully compliant with IEEE 802.11b/g/n wireless standards, It combines an ARM-CM3 MCU, WLAN MAC, a 1T1R capable WLAN baseband, and RF in the module. It have onboard antenna, and external antenna interface, RF output PIN also exist in the board. WizFi310 internally integrated TCP / IP protocol stack, supporting numerous protocols such as ARP, IP, ICMP, TCP, UDP, DHCP CLIENT, DHCP SERVER, DNS and other etc. It supports AP mode, Station mode. It also support rich AT command for all kinds of application. Users can easily and quickly use it to wifi networking and data transmission. The baud rate of module serial port is up to 921600bps, which can fully meet the low-rate applications.

In network part, WizFi310 supports storing network parameters in the module, and reduce time connect to network. The module has built-in WEB server, supporting wireless network parameters configuration, supporting wireless firmware upgrade. It also supports WPS and EasyConfig. In application part, HTTP, MQTT, MDNS and SSL also be supported.

It also provides a bunch of configurable GPIOs which are configured as SPI ,UART, I2C, I2S, PWM, for different applications and control usage. WizFi310M integrates internal 2M SRAM ,and 512KB DRAM and 2MB flash for complete WIFI protocol functions.

2. Features

Application

- UART serial AT command set operation
- Support for multiple baud rate
- Support wireless configuration and OTA upgrade firmware
- Support the UART interface, OTW(over the wire) upgrade function
- Support for fast networking, easyconfig, WPS function
- Support MDNS, MQTT, HTTP, TLS applications
- Support TSL1.2

Standards Supported

- 802.11b/g/n compatible WLAN
- 802.11e QoS Enhancement (WMM)
- 802.11i (WPA, WPA2). Open, shared key, and pair-wise key authentication services
- WIFI WPS support
- Light Weight TCP/IP protocol

WLAN MAC Features

- CMOS MAC, Baseband PHY, and RF in a single chip for 802.11b/g/n compatible WLAN
- Complete 802.11n solution for 2.4GHz band
- 72.2Mbps receive PHY rate and 72.2Mbps transmit PHY rate using 20MHz bandwidth
- 150Mbps receive PHY rate and 150Mbps transmit PHY rate using 40MHz bandwidth
- Backward compatible with 802.11b/g devices while operating in 802.11n mode
- Compatible with 802.11n specification
- Frame aggregation for increased MAC efficiency (A-MSDU, A-MPDU)
- Low latency immediate High-Throughput Block Acknowledgement (HT-BA)
- Long NAV for media reservation with CF-End for NAV release
- PHY-level spoofing to enhance legacy compatibility
- Power saving mechanism

WLAN PHY Feature

- 802.11n OFDM
- One Transmit and one Receive path (1T1R)

- 20MHz and 40MHz bandwidth transmission
- Short Guard Interval (400ns)
- DSSS with DBPSK and DQPSK, CCK modulation with long and short preamble
- OFDM with BPSK, QPSK, 16QAM, and 64QAM modulation. Convolutional Coding Rate: 1/2, 2/3, 3/4, and 5/6
- Maximum data rate 54Mbps in 802.11g and 150Mbps in 802.11n
- Fast receiver Automatic Gain Control (AGC)

Peripheral Interfaces

- Maximum 2 PCM with 8/16KHz sample rate
- Maximum 2 SPI supported with baud rate up to 41.5MHz.
- Support 4 PWM with configurable duration and duty cycle from 0 ~ 100%
- Support 4 External Timer Trigger Event (ETE function) with configurable period in low power mode
- Maximum 20 GPIO pins
- A high speed UART interface with baud rate up to 4MHz

3. System Block Diagram

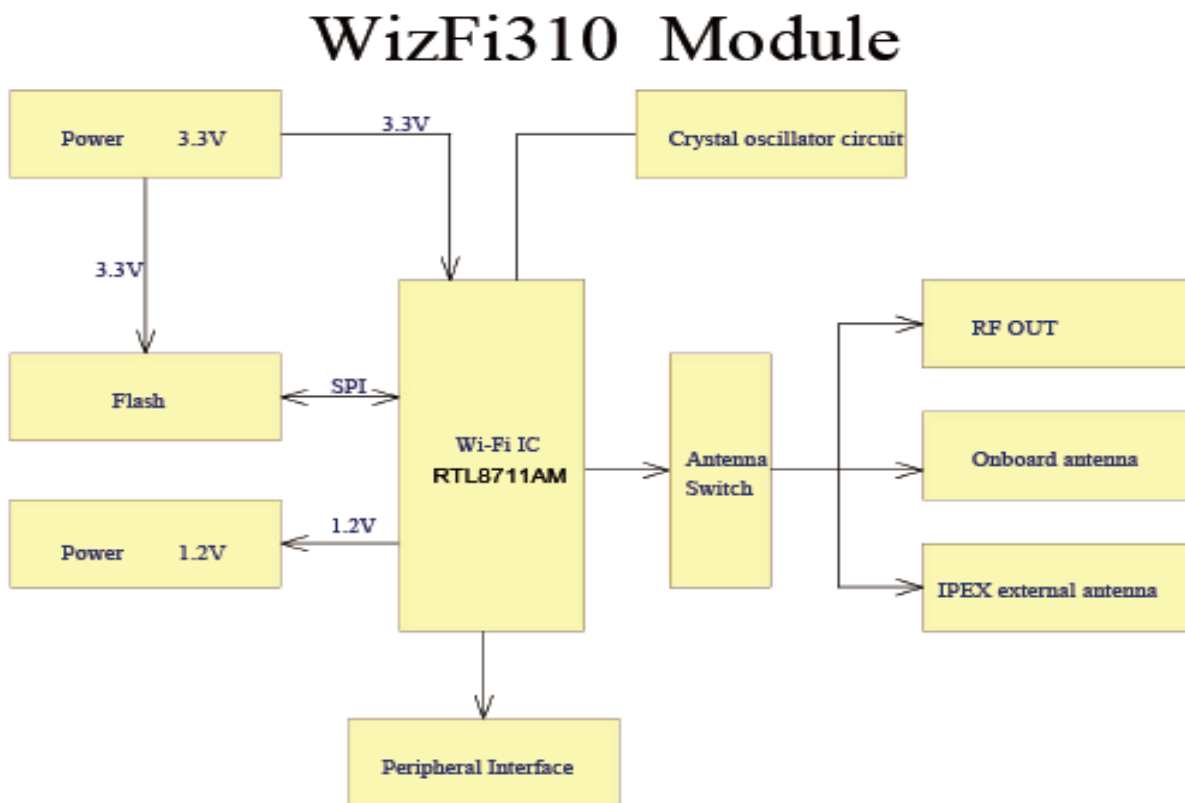

Figure 3-1 WizFi310 System Diagram

4. Module Hardware Description

4.1 Module photo



Figure 4-1 WizFi310 Top View



Figure 4-2 WizFi310 Bottom View

4.2 Package information

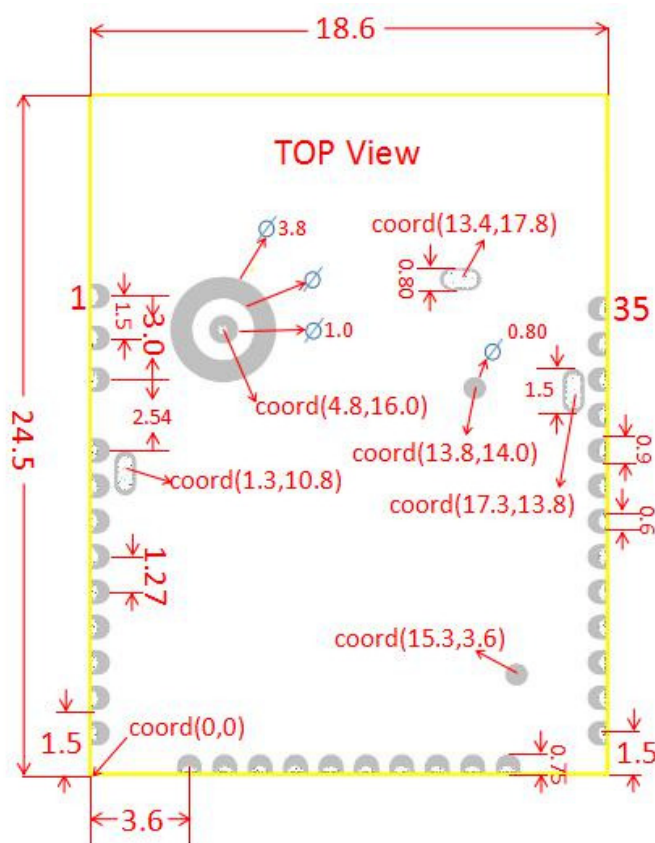

Figure 4-3 Module Pin Size (mm)

4.3 Pin definition

Table 4-1: Pin Definition

Pin Serial No.	Name	Type	Description
1,3,12,13,14,16,20,21,33	GND	Ground	All ground pins are connected to ground pad or the copper.
22	VCC3.3V	Power	3.3V power supply.
2	RF_OUT	O	2.4GHz RF output
4	VDDIO	Power	3.3V for Digital IO or digital blocks
11	RESET	I	Module reset pin, Active low.
17	LINK	O , PU	Work status indicator pin of module, output low effective.
23	TXD	O	Serial data communication interface send
26	RXD	I	Serial flow control pin, ready to receive, Active low.
24	RTS	O	Serial flow control pin, The default output low. Active low, ready to receive data / request the other party to send data.
25	CTS	I	Serial flow control pin, Input pull. Active low, ready to send data/request each other to send data. High level cannot send data, low level can send data.
Others	NC	NC	Remain disconnected when no use

Note:

1. I - input O - output PU – pulling up PD - pulling down NC - not connected
2. Pin in NC, remains disconnected

Link indicator:

OTA upgrade —50 ms high-speed flashing

EasyConfig, WPS configuration —200ms fast flash

After the network connection —On (Output Low)

Idle —1S slow flash

4.4 Reference design

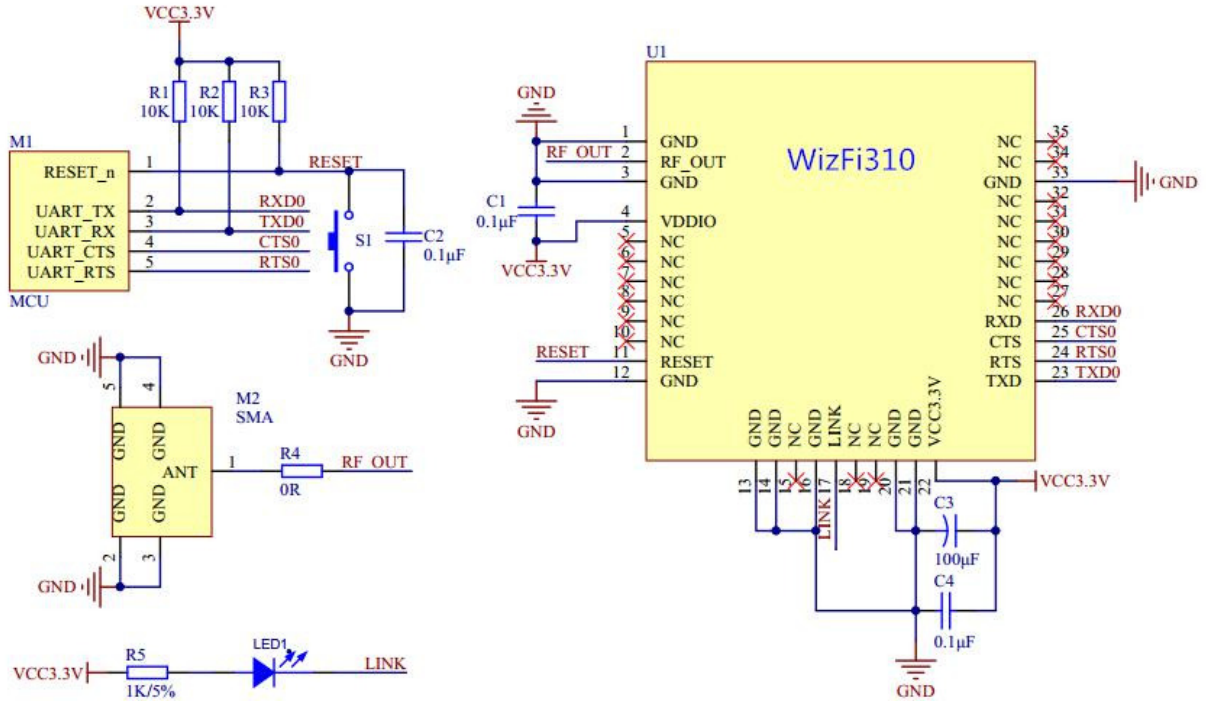

Figure 4-4 Module Typical Design Reference

5. Electrical Specification

5.1 General specification

ITEMS	CONTENTS
Operating Frequency	2.400-2.4835GHz
WiFi Standard	802.11b/g/n
Modulation	11b: CCK / DSSS 11g: OFDM 11n: OFDM
Host Interface	UART
Dimension	Typical (L x W):25mm x 19mm
Operation Temperature	-20°C to +55°C
Storage Temperature	-55°C to +125°C
Operation Voltage	3.3V±0.2V

5.2 802.11b Mode

ITEMS	CONTENTS				
Specification	IEEE802.11b				
Mode	DSSS/CCK				
Channel	CH 1to CH13				
1.Power Levels (calibrated)	Min.	Typ.	Max.	Unit	Note
1)13dBm Target (For each antenna Port)	11	13	14	dBm	
Frequency error	-25	0	+25	kHz	
3. Minimum input level sensitivity	Min.	Typ.	Max.	Unit	Note
1)11Mbps(FER≤8%)	---	-82	---	dBm	
2)Maximum input level (FER≤8%)	---	-10	---	dBm	

5.3 802.11g Mode

ITEMS	CONTENTS				
Specification	IEEE802.11g				
Mode	OFDM				
Channel	CH 1to CH13				
1.Power Levels (calibrated)	Min.	Typ.	Max.	Unit	Note
1)11dBm Target (For each antenna Port)	10	11	12	dBm	
2.Constellation error(EVM)@target power	Min.	Typ.	Max.	Unit	Note
1)54Mbps	---	-30	-28	dB	
3.Frequency error	-25	0	+25	kHz	
4.Minimum input level sensitivity	Min.	Typ.	Max.	Unit	
1)54Mbps(PER≤10%)	---	-78	---	dBm	
5.Maximum input level (PER≤10%)	---	-10	---	dBm	

5.4 802.11n HT20 Mode

ITEMS	CONTENTS				
Specification	IEEE802.11n HT20@2.4GHz				
Mode	OFDM				
Channel	CH 1to CH13				
1.Power Levels	Min.	Typ.	Max.	Unit	Note
1)11dBm Target (For each antenna Port)	9	11	12	dBm	
2.Constellation error(EVM)@target power	Min.	Typ.	Max.	Unit	Note
1)MCS7	---	-30	-28	dB	
3.Frequency error	-25	0	+25	kHz	

4.Minimum input level sensitivity	Min.	Typ.	Max.	Unit	
1)MCS7(PER≤10%)	---	-76	---	dBm	
5.Maximum input level (PER≤10%)	---	-10	---	dBm	

5.5 802.11n HT40 Mode

ITEMS	CONTENTS				
Specification	IEEE802.11n HT40@2.4GHz				
Mode	OFDM				
Channel	CH 1to CH9				
1.Power Levels (calibrated)					
	Min.	Typ.	Max.	Unit	Note
1)10dBm Target (For each antenna Port)	9	10	11	dBm	
2.Constellation error(EVM)@target power					
	Min.	Typ.	Max.	Unit	Note
1)MCS7		-30	-28	dB	
3.Frequency error					
	Min.	Typ.	Max.	Unit	Note
1)MCS7(PER≤10%)	---	-74	---	dBm	
5.Maximum input level (PER≤10%)	---	-10	---	dBm	

6. Order information

6.1 Order part number

Table 6-1 : Order model

Product	Describe	Antenna	MOQ(PCS)	Evaluation Board
WizFi310MA-XXXX	UART interface module, with on-board antenna	On-board	400	WizFi310-EVB
WizFi310MB-XXXX	UART interface module, with external antenna	External , U.fl/i.PEX	400	
WizFi310MC-XXXX	UART interface module, with RF output interface	RF output	400	

6.2 Module size

Packaging: Hard plastic pallets

Weight: <= 3 g/pcs

Table 6-2: Thickness (Height)

WizFi310	Thickness (Height)
With Shield	3.15±0.15mm

Note: In considering height design of the product, please consider your motherboard thickness error and product fit gap (recommended 0.10-0.15mm).

7. Contact information

Korea

FAE mailbox: main8096@wiznet.co.kr

Tel : +82-31-8023-5679

Fax : +82-31-8022-8090

Address: 5F Humax Village, 216 Hwangsaeul-ro, Bundang-Gu, Seongnam-Si, Gyeonggi-Do, Korea

8. Modification records

Edition	Author	Date	Modification content
V1.0	LucidMinsu Jeun	2015/12/4	Creating document

FCC Caution

Any Changes or modifications not expressly approved by the party responsible for compliance could void the user's authority to operate the equipment.

This device complies with part 15 of the FCC Rules. Operation is subject to the following two conditions:

- (1) This device may not cause harmful interference, and
- (2) This device must accept any interference received, including interference that may cause undesired operation.

Radiation Exposure Statement

This equipment complies with FCC radiation exposure limits set forth for an uncontrolled environment. This equipment should be installed and operated with minimum distance 20cm between the radiator & your body.

This module is intended for OEM integrator. The OEM integrator is still responsible for the FCC compliance requirement of the end product, which integrates this module

The final end product must be labeled in a visible area with the following " Contains FCC ID:2AKKWWIZFI310.