

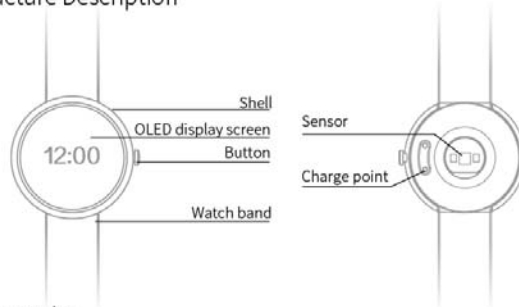

User Manual

### 1. Structure Description



### 2. Accessories

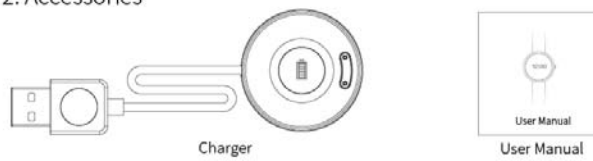

### 3. Operation Instruction

a: Search and download "H Band" from App store for iPhone. Search "H Band" from Google play for Android phone.



Scan QR code download



b: Connect to Bluetooth

- ①. Switch on the Bluetooth from mobile phone and search for Bluetooth device.
- ②. Make mobile phone near to the device, press the key from watch light up the screen, refresh the device list and scan the name with "V06" Bluetooth device, select the device name and connect. You need input the initial password "0000" for 1st connection. Current device information will be showed on the phone after the connection is successful. You can use all the functions of the device after connected.
- ③. If you want to delete the connection, click "my device" on the bottom and select "disconnect" item.



c: Please ensure sufficient power for the device otherwise the device cannot boot properly, please connect the charger to charge the device and the device will automatically power on.

#### 4. Main Function Description

- ①. Data modeling (very important)

When using this product for the first time, the device need make your body data modeling, you need to ensure continuous wear for 48 hours to complete the model, please wear the sensors on the back of the watch completely snapping your skin, be careful not to wear loose, improperly wearing can affect data accuracy or cannot collect the data.

#### ②. Sport Blood Pressure Test

In order to ensure data accuracy, after entering the blood pressure measurement you need to relax, make the device same level with your heart and keep silence.



Tips: This function is reference only for provides blood pressure before and after sport, not for medical purposes and not suitable for hypertension patients!

#### ③. Real-time Heart Rate Monitor

After 30 minutes 1st time wearing, the bracelet will calculate out your scientific and rational healthy heart rate range according to your personal data input and 24 hours monitoring your heart rate, scientific analysis your heart rate change. Vibrating alert when an exception is detected. Heart rate will be tested automatically every 5 minutes and every half hour interval averages of the measured results are saved. Continuous testing data will be available after APP sync.

#### ④. Step counter and running mode

The device will automatically record the wearer steps such as moving step and on the basis of information entered on the APP (height, weight, age, gender)

calculated calorie consumption and distance traveled needed, display on the device and APP. Click the "start" button from APP "sport" item to enter running mode and record the wearer's running time, speed and calories. Movement data can be shared between Wechat and other social applications.

#### 5. Sleep Monitor

The device will record and analyze sleep time, scientific assessment your sleep quality and give reasonable suggestions to improve the quality of your sleep. You can clearly know the time you go to sleep, deep sleep, light sleep time and waking time according to sleep monitor. Each sleep period has a piece of clear sleep line graph for you then you can adjust your sleep time and make it more regularly.

#### 6. Alarm function

The device provide silent vibration alarm function, it will begin silent vibration at your preset time without any noise so that avoid any negative stimulus from suddenly sound alarm to the heart and no influence to others at the same time.

Tips: It only be effected for setup with the condition of connected to the device. The device will remind you with a slight vibration at the scheduled time, you can also choose to On/Off the alarm.

#### 7. Personal data Setup

In order to ensure the accuracy, please input your real data!

Personal data: gender, weight, age and height, click OK after input finished.

#### 8. Button Function Description:

A. Power on: Long press power key 3S, device enter the main interface (time).

B. Power off: long press the button 3S, power off with vibration.

C. Short press: Mode switch.

D. Enter heart rate mode  the test will begin 1S later automatically, the test will be showed after the test finished and exited 60S later.

E. Enter blood pressure test mode  and begin blood pressure test 1S later, show the result after test finished.

F. Enter pedometer mode  display current step with moving step icon, the 8 progress bar shows 100% target step, percentage of dots means the completed schedule.

G. Enter sleep mode  and show current sleep data.

H. Enter distance mode  shows current steps corresponding to the distance.

I. Enter Calorie mode  shows current number of steps corresponding to the consumption of Calorie.

J. Alcohol allergy detection  and arrhythmia alert  ,

when alcohol allergy or arrhythmia detected the bracelet will remind with vibration.

K. Alarm  call  message , when the call or message coming, device will remind with vibration and relative icons.

L. Other display interface 3S exit without operation.

M. Full Bluetooth Icon will be showed after Bluetooth connected.

N. Alarm Icon will be showed at the preset alarm time.

#### 5. Attention

- ①. Please try to keep the APP connect to your device and sync data in time.
- ②. Depending on different phones from user, several seconds delay for data reading is allowed.
- ③. Depending on different phones from user, APP may quit occasional or Bluetooth intermittent phenomenon, restart the device or download the APP again to solve the problem .
- ④. When Bluetooth disconnected, the device will automatically search within 20 minutes.
- ⑤. If user needs to replace with same model device, the app will remind: click "sync" the equipment will cover existing (the current three days) data, if click "no", then pop-up warning message: select "delete" all personal data will be removed,

the system will remodeling, otherwise monitoring effect is not accuracy, "does not delete"then exit the system, please choose carefully!

⑥. For the 1st time using, the device need setup your personal data for modeling and may appear inaccurate data until continuously wear for 48 Hours and the data will be more accurate after long time using.

#### 6. FAQ

①: Can't find device when pairing device?

a: Please make sure the bluetooth from mobile is turned on, distance between phone and device is no more than 0.5m. After pairing Bluetooth communication range within 10m.

b: Please make sure the device is not under low battery. If there is still problem after full charge, please contact with us.

②: Why the occasional Bluetooth connect error?

Some smart phone Bluetooth service will be abnormal when turned on. Please reboot the Bluetooth or reboot smart phone and make it connected.

③: How to update the device

Make sure the device is connected with app. Enter the APP "my settings" and select firmware update.

### **FCC Statement**

This equipment has been tested and found to comply with the limits for a Class B digital device, pursuant to part 15 of the FCC rules. These limits are designed to provide reasonable protection against harmful interference in a residential installation. This equipment generates, uses and can radiate radio frequency energy and, if not installed and used in accordance with the instructions, may cause harmful interference to radio communications. However, there is no guarantee that interference will not occur in a particular installation. If this equipment does cause harmful interference to radio or television reception, which can be determined by turning the equipment off and on, the user is encouraged to try to correct the interference by one or more of the following measures:

- Reorient or relocate the receiving antenna.
- Increase the separation between the equipment and receiver.
- Connect the equipment into an outlet on a circuit different from that to which the receiver is connected.
- Consult the dealer or an experienced radio/TV technician for help.

To assure continued compliance, any changes or modifications not expressly approved by the party.

Responsible for compliance could void the user's authority to operate this equipment. (Example- use only shielded interface cables when connecting to computer or peripheral devices).

This equipment complies with Part 15 of the FCC Rules. Operation is subject to the following two conditions:

- (1) This device may not cause harmful interference, and
- (2) This device must accept any interference received, including interference that may cause undesired operation.

RF warning statement:

The device has been evaluated to meet general RF exposure requirement. The device can be used in portable exposure condition without restriction.