

MODEL **PORTI-SM40**

(Mobile Printer)

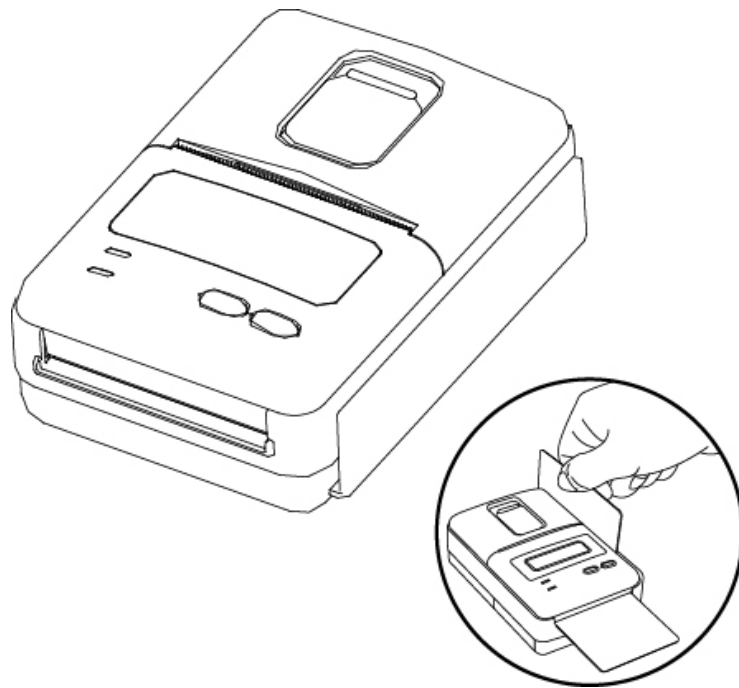

WOOSIM SYSTEMS Inc.

**#501, Daerung Technotown 3th,
448, Gasan-Dong, GeumChun-Ku,
Seoul, Korea**

Tel : +82-2-2107-3700

Fax : +82-2-2107-3707

URL: <http://www.woosim.com>

Copyright

Porti-SM40 Mobile printer operator's manual.

Copyright ©2008 by Woosim Systems Inc.

All rights reserved.

The information contained in this manual is the property of Woosim Systems Inc. and may not be reproduced in whole or in part without the prior written permission of Woosim Systems Inc.

Trademark



a registered trademark of Woosim Systems Inc.

All other trademark are the properties of their respective companies.

Caution

Some semiconductor devices are easily damaged by static electricity.

You should turn the printer "OFF", before you connect or removed the cable on the rear side, in order to guard the printer against the static electricity.

If the printer is damaged by the static electricity, you should turn the printer "OFF"

Notice

- The contents of this manual are subject to change without notice.
- Changes or modifications not expressly approved by the party responsible for compliance could void the user's authority to operate the equipment.
- This device complies with part 15 of the FCC Rules. Operation is subject to the following two conditions:
 - (1) This device may not cause harmful interference, and (2) this device must accept any interference received, including interference that may cause underired operation.

▣ Introduction

The **Porti-SM40** is the ideal solution for Mobile banking system , Retail, point of sales, Credit card Transaction, other traveling and mobile computing etc.

The general features of Porti-SM40 printer are as follows:

- ▶ Pocket size(80.5×113.5×46mm)
- ▶ Light weight(300g) for true mobility
- ▶ Very silent printing thru direct thermal printing method
- ▶ High speed(80mm/sec, MAX)
- ▶ UART(RS-232C or TTL), Bluetooth interface
- ▶ Support Magnetic Stripe Reader & Smart card reader
- ▶ Support Graphic LCD(128×32dots) with Blue LED Backlight
- ▶ Support text and graphic printing
- ▶ Support bit-image(logo), firmware download
- ▶ Easier paper roll loading by CLAMSHELL design
- ▶ One touch paper cover
- ▶ Printer door open & Paper-out sensor
- ▶ Microsoft Windows 98/ME/XP/2000 compatible.
- ▶ In field programming – Update Firmware, Download Fonts and Logos
- ▶ Support bit-image(logo) download.
- ▶ Flow control : Software (XON/XOFF)
 - ※ Hardware flow control not supported in printer.

■ Operating Precautions

Please follow the precautions below to enjoy and maintain the full performance of the printer.

▶ Using the Printer

- Be careful not to drop or bump the printer on a hard surface.
- Do not install the printer in direct sunlight or such areas.

Suitable environment for the use of the printer is as follows:

- ◆ Operating temperature : -20°C to 55°C
- ◆ Relative humidity : 0% to 95% (No condensation)
- Do not install the printer near devices that generate strong electromagnetic fields such as a copy machine.
- Do not open the platen cover during printing .
- Do not remove or reinstall the communication cable during printing or transmission.
- Do not touch the connectors of the communication during printing.
- Switch the POWER OFF when not in use.
- Do not use alcohol or other solvent.
- The AC adapter, the battery charger and the battery pack may become warm when in use. This is normal and is not a malfunction.
- When the battery pack is used at low temperature, the length of time the printer can be used may be shortened.

▶ Thermal Paper Handling

- Store the thermal paper in a cool, dry and dark place.
- Do not rub the paper with hard object.
- Do not leave the paper with hard object.
- Do not allow plastic film, erasers, or adhesive tape to touch the paper for long periods.
- Do not stack the thermal paper with diazo copies immediately after copying or wet-type copies.
- Do not use chemical glue.
- Always use the clean thermal paper.

CONTENTS

Copyright.....	2
Trademark.....	2
Caution.....	2
Operating Precautions.....	4
1. Outline.....	7
1.1. Model classifications.....	7
1.2. Product Part Number System.....	7
1.3. Specifications.....	8
2. Setting up the printer.....	10
2.1. Printer & Accessories.....	10
2.2. Printer Features.....	11
2.3. Replacing paper roll.....	13
2.4. Power supply.....	14
2.4.1. Specified power supply.....	14
2.4.2. Installing the battery.....	14
2.4.3. Recharging the battery pack.....	15
2.5. Set operation mode.....	16
3. Interface.....	19
3.1. UART(RS-232C or TTL).....	19
3.2. Bluetooth.....	20
3.2.1 Bluetooth channel organized table.....	20
4. Smart Card Module.....	21
4.1. General Spec.....	21
4.2. Communication Protocol Sequence.....	22
4.2.1. Regular Operation.....	22
4.2.2. Irregular Operation (Communication Error).....	22
5. Using the printer.....	23
5.1. Control panel.....	23
5.2. The self test.....	24

6. Consumable Parts.....	25
6.1. Recommended paper.....	25
6.2. Printing position.....	25

1. Outline.

1.1. Model classifications.

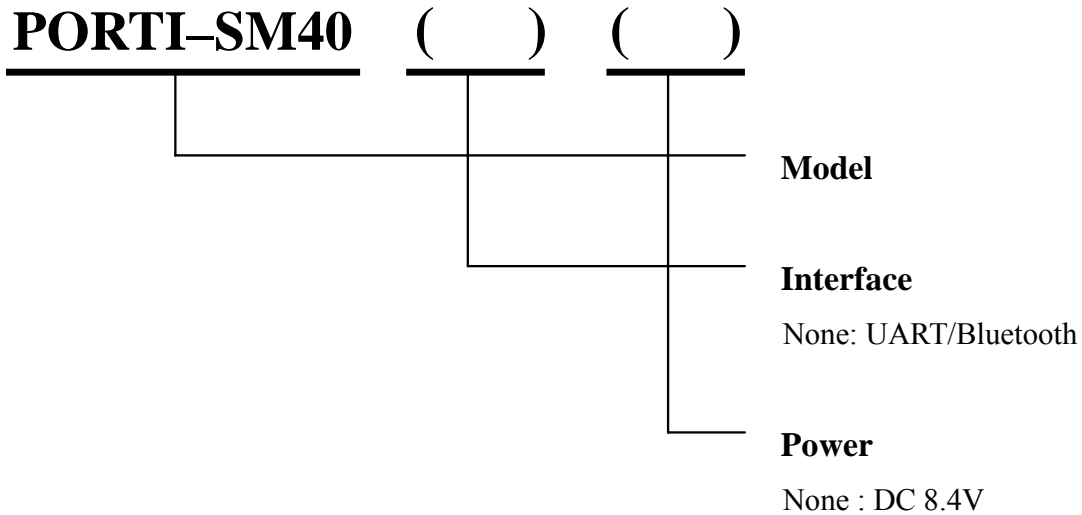

1.2. Product Part Number System.

Model name / Interface Spec.

S40
SC30
W25
.
.
.

Wired		Wireless	
A	RS-232C	1	Bluetooth
B	TTL	2	IrDA
C	USB	0	None
D	RS-485		
E	Parallel		
Z	None		

Example) 1. Porti-S40 Serial/Bluetooth Part No. ⇒ S40/A1
 2. Porti-SC30 Bluetooth Only Part No. ⇒ SC30/Z1

Note) The above table is the interface format which is supported.
 But some of the interfaces are not supported according to the product and please contact us, if you have any questions regarding the interface.

1.3. Specifications.

Item	Specifications
Print method	Direct thermal line printing
Characters per line	42cpl (MAX)
Character size	Eng. : 9×24dots, 12×24dots Kor. : 16×24dots, [24×24dots]
Optional Characters	Simplified/Traditional Chinese, Arabic, Cyrillic, Russian, Turkish, Greek, Japanese, Persian, Latin9 and Others upon request.
Resolution	203dpi, 8dots/mm
Print width	2-inch (48mm, 384dots)
Print speed	80mm / sec (MAX)
Dimension	80.5×113.5×46 mm
Weight	300g (Including battery & roll paper)
Interface	UART(RS-232C or TTL) / Bluetooth Ver 2.1 + EDR
Paper roll	Thermal roll paper (57mm wide, 40ø)
Barcodes	1-dimension : Code128, EAN 128, Code39, I2/5, Code93 UPC, EAN, KAN, JAN, CODABAR 2-dimension : PDF417, QR Code, DATA Matrix
Memory	MCU : 32bit RISC, FLASH : 4 Mbytes, RAM : 8 Mbytes
Receive buffer size	1M bytes
MSR	ISO 7810 / 7811 / 7812 1&2 or 2&3 Track Reading
Smart card reader	ISO 7816 Compliant (EMV level 1 Certified) / T=0, T=1 support / 2 SAM (Security Application Module)
LCD	128 × 32 Dots FSTN (Blue LED Backlight)
Battery	Rechargeable 7.4V DC/ 1,100mAh (Li-ion)
Battery duration	1 hour continuous printing
Battery charger	Input (100~250V AC, 50~60Hz) Output(8.4VDC/0.8A), 4hours full charge time

Item	Specifications	
Environment conditions	Temperature	-20°C ~ 55°C (operating)
	Humidity	0% - 95% (operating)
MCBF(Mean Cycle Between Failure)	Mechanical	37,000,000 lines
	Head	Approximately 50 Km

2. Setting up the printer.

2.1. Printer & Accessories

Your printer box should include these items. If any items are damaged or missing, please contact your dealer for assistance.

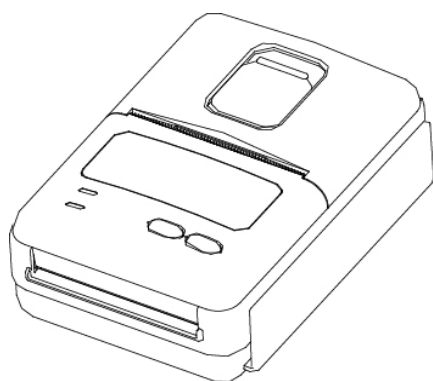

PORTI-SM40

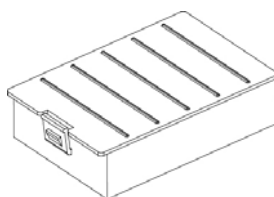

Battery Pack

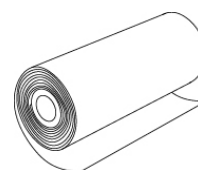

Paper Roll

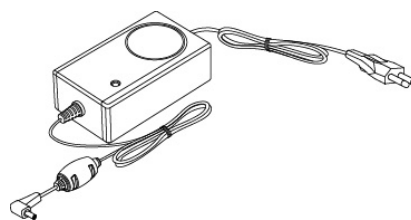

Battery Charger

▼ OPTIONAL

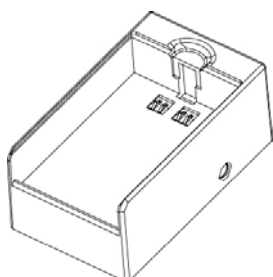

Extra Charger

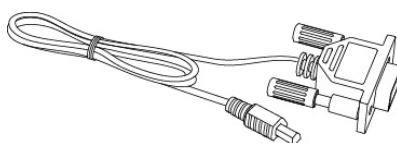

Communication Cable

2.2. Printer Features

► Part Name

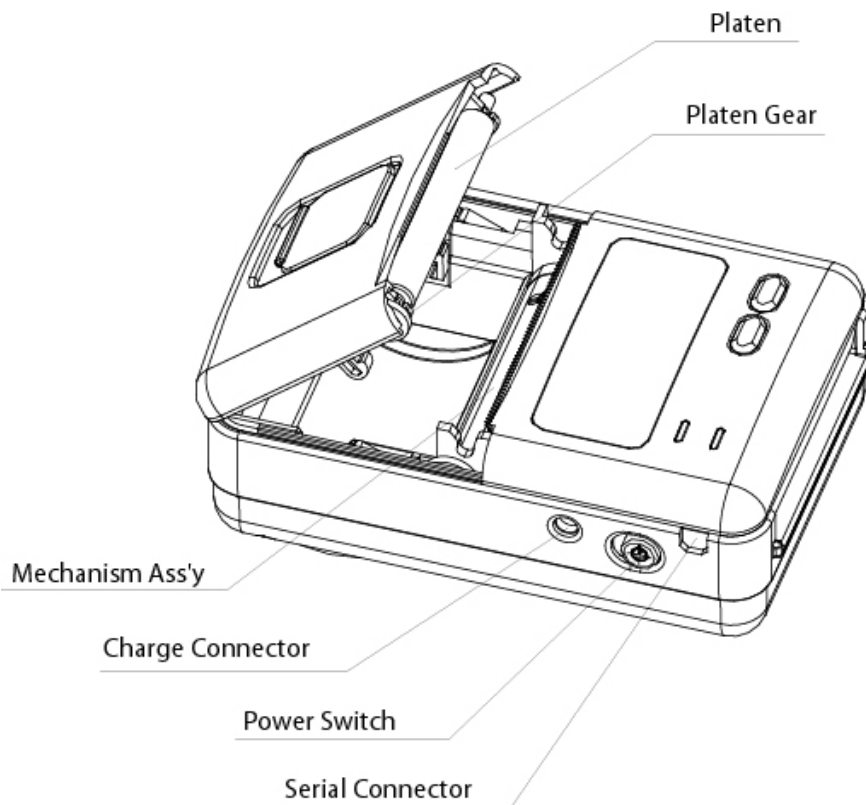
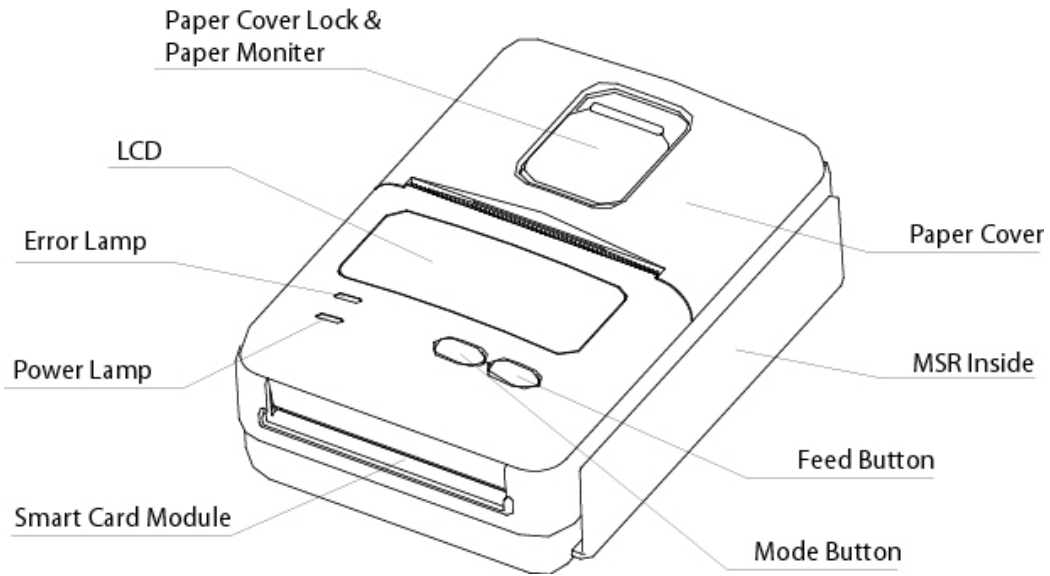

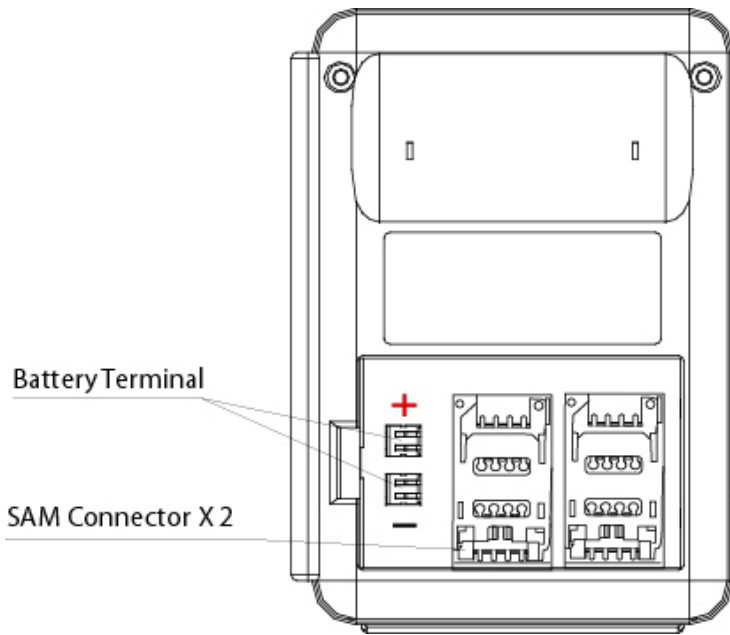

► **Dimensions**

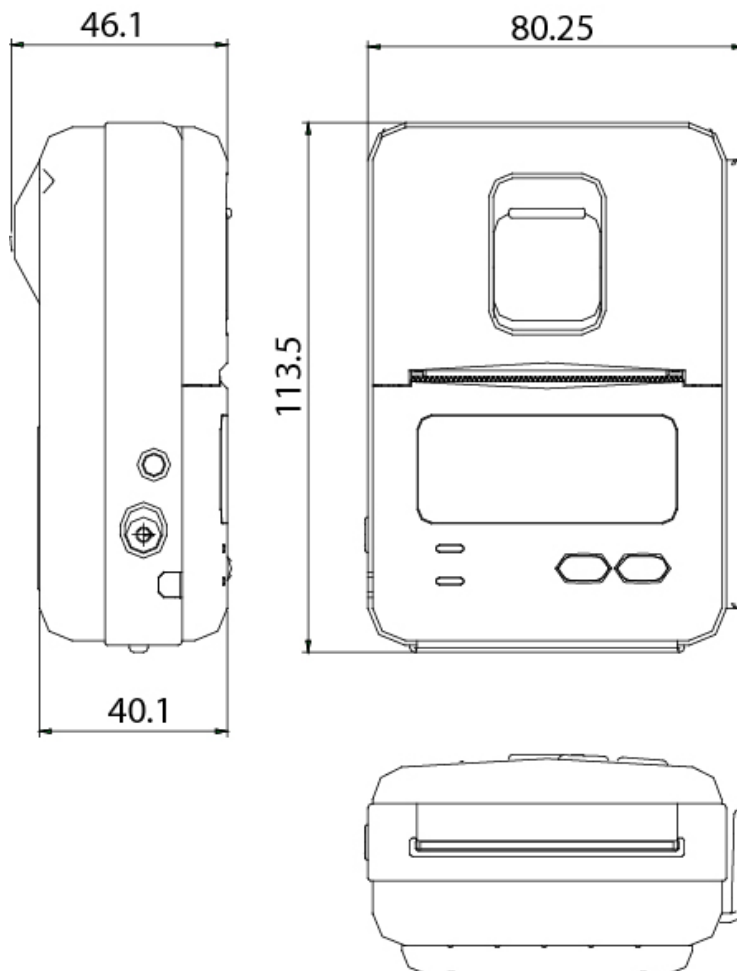

2.3. Replacing paper roll.

Note : Be sure to use paper rolls that meet the specifications.
Do not use paper rolls that have the paper glued to the core because the printer cannot detect the paper end correctly.

1. Make sure that the printer is not receiving data; otherwise, data may be lost.
2. Open the paper cover by placing your fingers under the paper cover lock and pull a paper cover lock open.

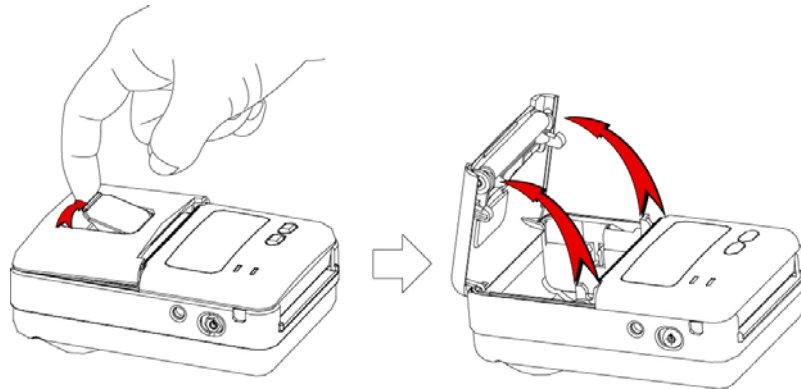

3. Insert a new paper roll as shown.

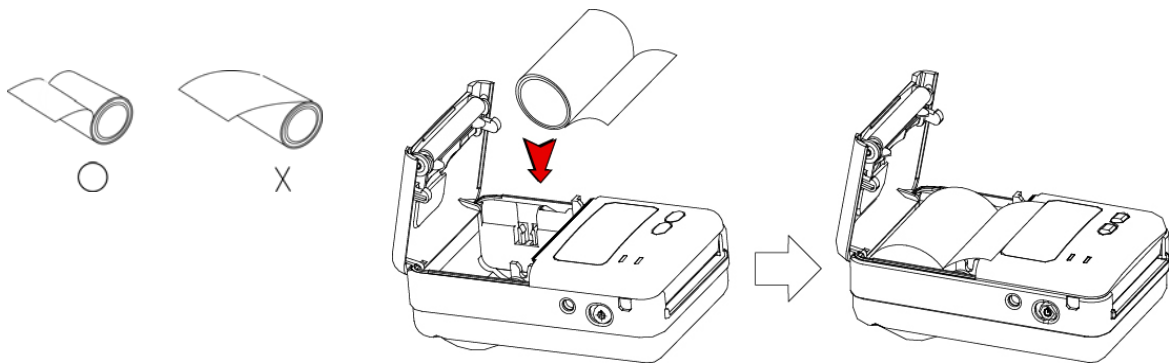

4. Tear the excess paper off using the edge of paper door as a tear bar.

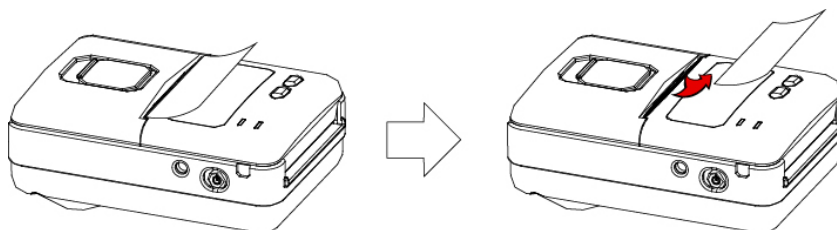

2.4. Power supply

2.4.1. Specified power supply.

The following specification is requested for Power supply.

Battery Charger : DC 8.4V/0.8A

Avoid using power supply which its power capacity of power current is extremely high.

2.4.2. Installing the battery

NOTE :

- Before installing or removing the battery pack, ensure the printer is OFF.
- If the printer is not used for long period of time, remove the battery pack from the printer.

CAUTION : Risk of explosion if battery is replaced by an incorrect type.

Dispose of used batteries according to the instructions.

① To install battery pack, proceed as follows:

- Insert the Battery pack in the direction of the arrow.

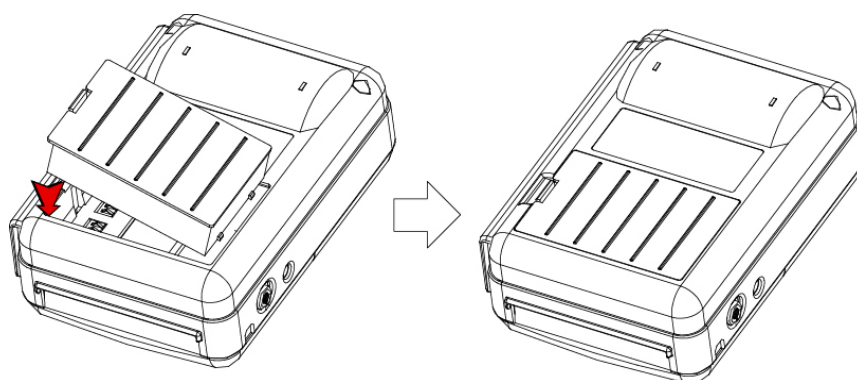

② Reverse the order to remove the battery pack.

③ The battery pack install into extra charger.

- Inse

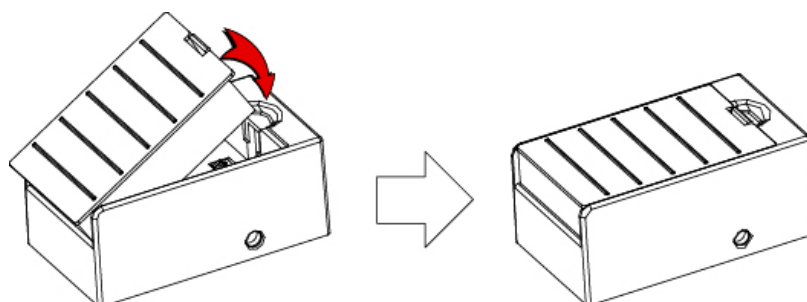

2.4.3. Recharging the battery pack

For recharging the battery pack, install the battery pack in the printer or the extra charger.

Insert the Battery Charger to the charge connector of the printer or the extra charger.

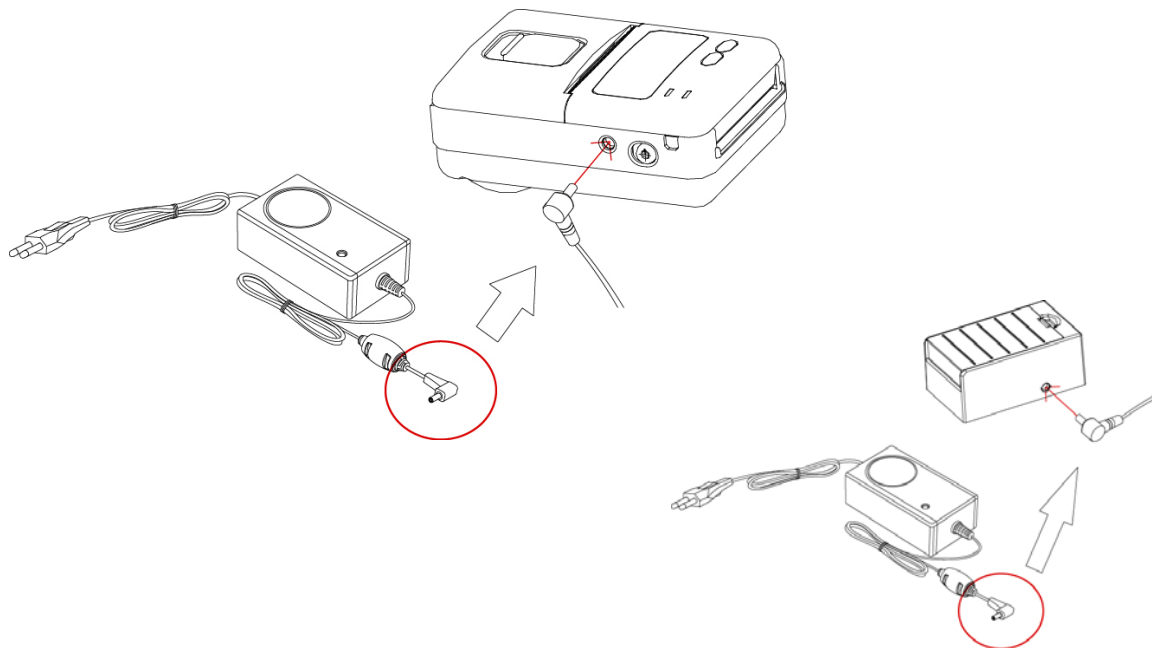

- NOTE :**
- While charging the printer, turn off the printer power.
 - Do not remove the battery during charging.
 - The battery is consumable parts and when purchasing, compared to the use hour is gradually decreases. (Warranty 6 month)
 - If the printer is not used for a long time, unplug the power cord from the printer and outlet.
 - The recharging time depends on the voltage level and ambient temperature of the battery. Normally, it takes about 4 to 5 hours to recharge a battery pack.
 - You must use only the supplied adapter.
 - Red Lamp : charging the battery.
Green Lamp: charging is finished.

2.5. Set operation mode.

1. Change the mode and option using the mode Code (Table1).

- **MODE button** : changing Printer MODE status.

- **FEED button** : changing OPTION status.

2. [Example] The defaults of the printer are :

UART/ 9600 BPS/8 DATA BIT/ NO Parity/1 STOP BIT/ Density LOW

If a user wants to modify the defaults with

Bluetooth/38400 BPS/7 DATA BIT/Even Parity/2 STOP BIT/Density HIGH

▶ Press **MODE Button** until **Error Lamp** twinkles 5 times.

→ You will see present **COMMUNICATION** mode in the LCD.

→ Press the **MODE Button** two times.

(The interface mode has set to Bluetooth mode.)

▶ Press **FEED button** one time.

→ You will see present **BAUD RATE** mode in the LCD.

→ Press **MODE Button** 2 times.

(The baud rate has set to 38,400 bps)

▶ Press **FEED button** one time.

→ You will see present **DATA BIT** mode in the LCD.

→ Press **MODE Button** one time.

(The data bit has set to 7 data bit.)

▶ Press **FEED button** one time.

→ You will see present **PARITY BIT** mode in the LCD.

→ Press **MODE Button** 2 times.

(The parity bit has set to Even parity bit.)

- ▶ Press **FEED button** one time.
 - You will see present **STOP BIT** mode in the LCD.
 - Press **MODE Button** one time.
 - (The stop bit has set to 2 stop bit.)

- ▶ Press **FEED button** one time.
 - You will see present **DENSITY** mode in the LCD.
 - Press **MODE Button** two times.
 - (The density has set to high.)

If all the mode have set, press the **FEED Button** and the **MODE Button** at the same time after then release the buttons at the same time.

The printer will print out the mode status which has modified.
(Bluetooth/38,400 BPS/ 7 DATA BIT/Even Parity/ 2 STOP BIT / Density HIGH)

If the status is not correct, please try it again according to the procedure.

Mode No.	Printer Mode (Mode Button)	Option No.	Option (Feed Button)
1	Communication Port	1	UART
		2	UART (Protocol)
		3	Bluetooth
		4	Bluetooth (Protocol)
2	Baud Rate	1	9600 bps
		2	19200 bps
		3	34800 bps
		4	57600 bps
		5	115200 bps
3	Data Bit	1	7 Data bit
		2	8 Data bit
4	Parity Bit	1	No Parity
		2	Odd Parity
		3	Even Parity
5	Stop Bit	1	1 Stop Bit
		2	2 Stop Bit
6	Density	1	Low Density
		2	Medium Density
		3	High Density
7	Mark	1	No use
		2	Use
8	Sensor	1	Sensor Low
		2	Sensor Medium 1
		3	Sensor Medium 2
		4	Sensor High

<Table 1>

3. Interface.

3.1. UART(RS-232C or TTL)

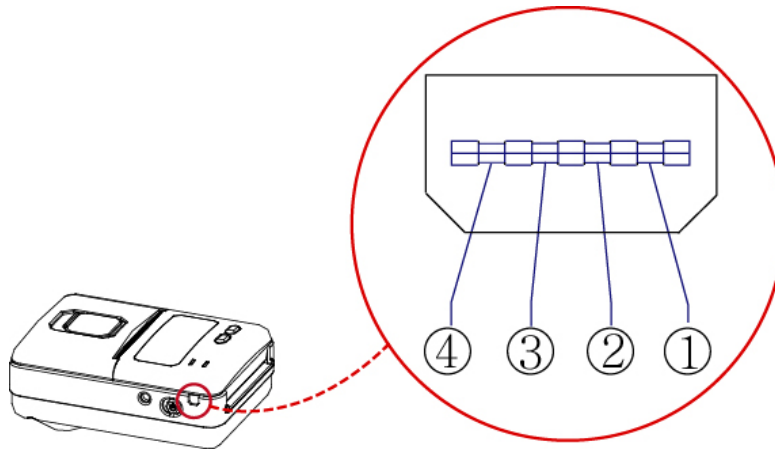

The Porti-SM40 printer has a RS-232C or TTL interface and is connected by means of a 4 pin mini USB socket. In the following table, the signals present on the Mini-USB socket are listed:

Pin No.	Name	Direction	Function
1	TxD	Output	Transmit Data
2	RxD	Input	Receive Data
3	CTS	-	-
4	GND	-	Ground

* Applicable connector : SUNG KYUNG (CM-720)

NOTE : ● When data receiving, when it removes the communication cable, it loses a data.

3.2. Bluetooth

Category	Specification
Bluetooth Spec.	Bluetooth V2.1 / Class2 (10m)
Frequency Range	2.4GHz ISM BAND (2.402~2.480GHz)
Data Transmission Rate	57600bps Fixed.
Data bit	8 Data bit Fixed.
Parity bit	No parity Fixed.
Stop bit	1 Stop bit Fixed.
Output	Below 3mW/MHZ
Modulation type/rash way	GFSK SYSTEM / PLL

3.2.1 Bluetooth channel organized table

CH	MHz	CH	MHz	CH	MHz	CH	MHz	CH	MHz	CH	MHz	CH	MHz	CH	MHz
1	2402	11	2412	21	2422	31	2432	41	2442	51	2452	61	2462	71	2472
2	2403	12	2413	22	2423	32	2433	42	2443	52	2453	62	2463	72	2473
3	2404	13	2414	23	2424	33	2434	43	2444	53	2454	63	2464	73	2474
4	2405	14	2415	24	2425	34	2435	44	2445	54	2455	64	2465	74	2475
5	2406	15	2416	25	2426	35	2436	45	2446	55	2456	65	2466	75	2476
6	2407	16	2417	26	2427	36	2437	46	2447	56	2457	66	2467	76	2477
7	2408	17	2418	27	2428	37	2438	47	2448	57	2458	67	2468	77	2478
8	2409	18	2419	28	2429	38	2439	48	2449	58	2459	68	2469	78	2479
9	2410	19	2420	29	2430	39	2440	49	2450	59	2460	69	2470	79	2480
10	2411	20	2421	30	2431	40	2441	50	2451	60	2461	70	2471		

4. Smart Card Module

4.1. General Spec.

- ▶ Contact Smart Card Reader Module for ISO/IEC-7816
- ▶ Support Asynchronous Protocol T=0,T=1
- ▶ Smart Card Connection
 - Short Circuit Current Limitation
 - 6KV ESD Protection on whole Smart Card Interface
 - Connector : Friction Type with Smart Card presence detection
- ▶ 2 SAM (Security Application Module)
- ▶ EMV Level 1 Certified

4.2. Communication Protocol Sequence

4.2.1. Regular Operation

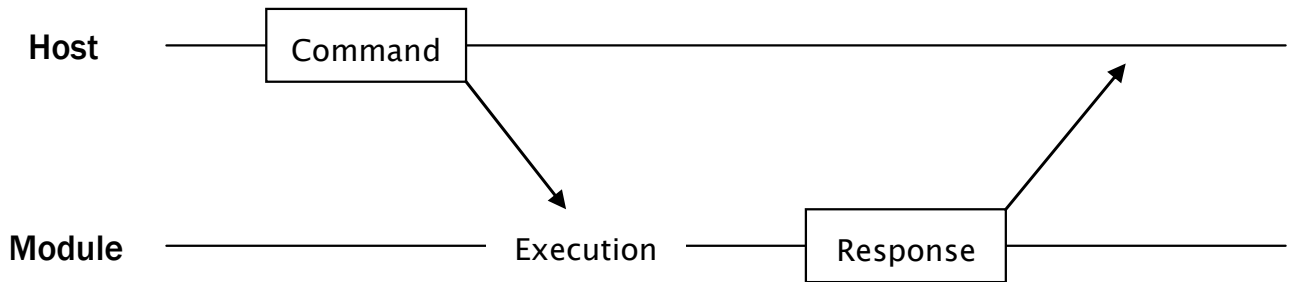

4.2.2. Irregular Operation (Communication Error)

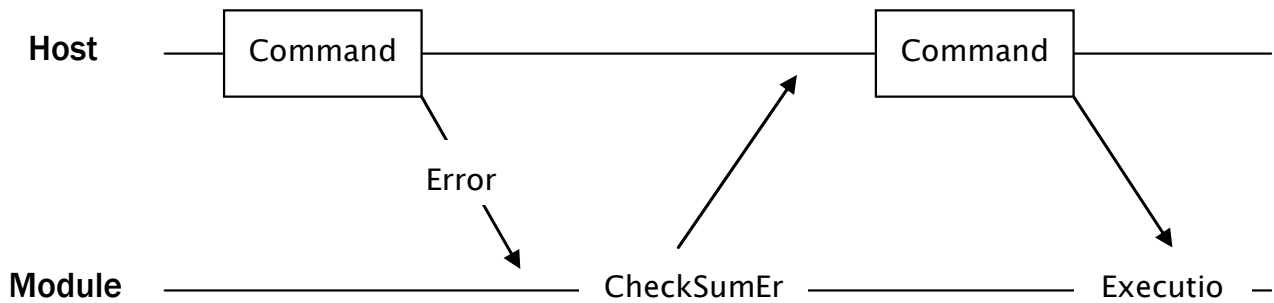
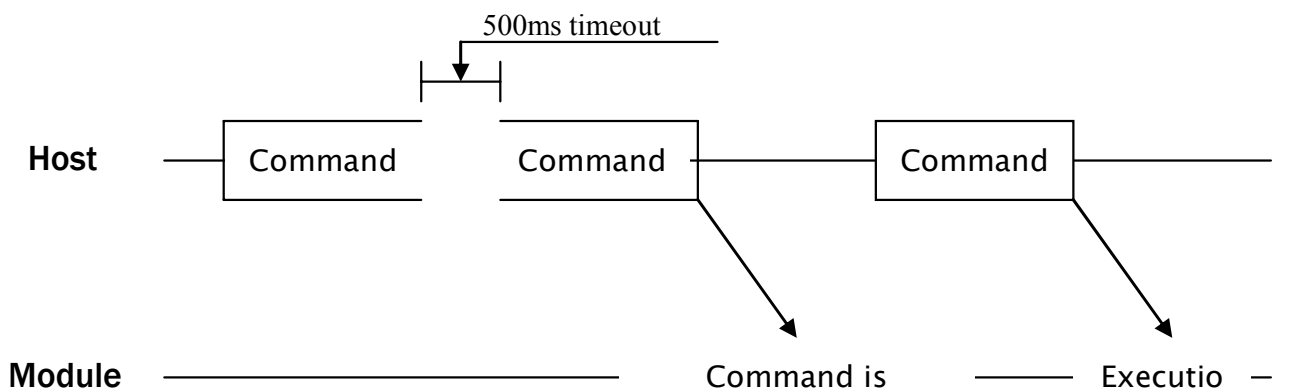

5. Using the printer.

5.1. Control panel.

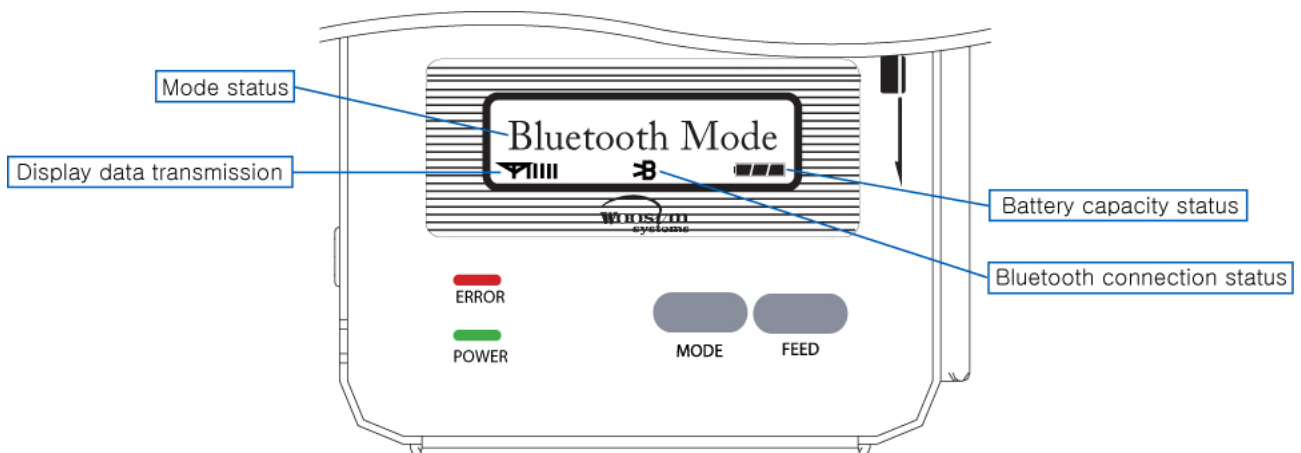

► Button

- FEED Button :

When the printer is on, paper can be feed manually by pressing and holding the FEED button for more than one second.

- MODE Button :

MODE Button is for use to change communication mode.

(Refer to **2.5. Set operation mode** for details about mode conversion)

► Panel lamp

-POWER (Green) : Printer is ON and ready to receive data.

-ERROR (Red) : Indicated a fault condition or a printer error.

(i.e : no paper, paper cover opened. etc.)

► LCD

- LCD will display most of the printer status.

(i.e : current printer status, paper out, indicated remaining battery, Bluetooth connection etc.)

5.2. The self test.

The self test procedure will check most of the printer functions. For self test, turn on the power while holding down the FEED Button. The Self-Test checks the following :

- 1) Make sure paper roll has been installed properly.
- 2) The Self-Test prints the current printer status, which provides the control ROM version and the communication method setting.
- 3) After printing the current printer status, Self-Test will print a pattern using the built-in character set.
- 4) The Self-Test automatically ends.

The printer is ready to receive data as soon as it completed the self test.

6. Consumable Parts.

6.1. Recommended paper.

Type	: Thermal Paper
Paper width	: 57mm
Paper thickness	: $60 \pm 5 \mu\text{m}$
Outer diameter	: $\text{Ø}40\text{mm}$ or less
Recording side	: Outside of roll



Cautions

1. Do not paste the paper to the core. And the roll paper which has Near end mark printing on its near end is recommended.
2. Chemicals or oil may change the color of paper, or printed Characters may fade.
3. Change of paper color starts from approx $70\text{ }^{\circ}\text{C}$.
Pay attention to heat, humidity and sun light.
4. Color of paper may be changed by being scratched by nail or hard metal, etc

6.2. Printing position.

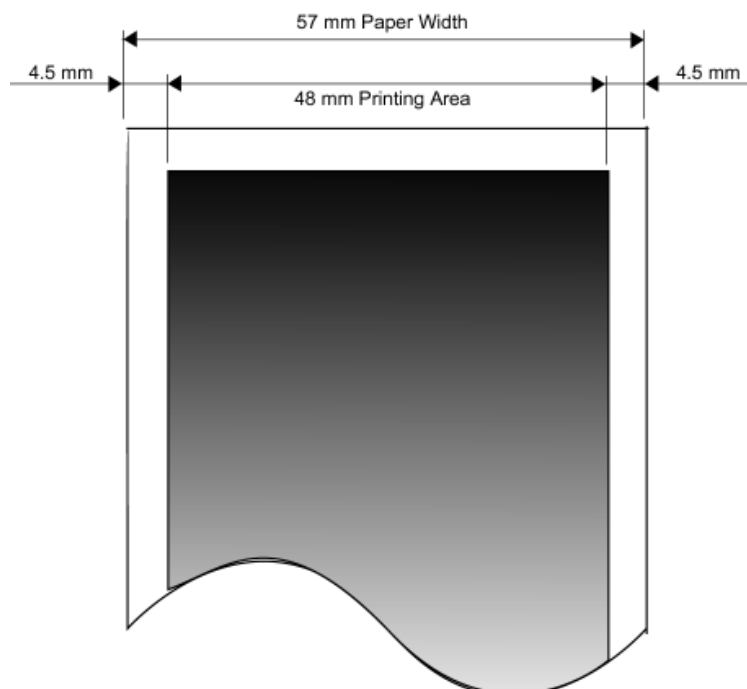

FCC ID : QDDPORTI-SM40-ABC

THIS DEVICE COMPLIES WITH PART 15 OF THE FCC RULES.

Operation is subject to the following two conditions; (1)

This device may not cause harmful interference, and (2) this device must accept any interference received,

including interference that may cause undesired operation.

CAUTION : Changes or modifications not expressly approved by the party responsible for compliance could void the user's authority to operate the equipment.

Note: This equipment has been tested and found to comply with the limits for a Class B digital device, pursuant to part 15 of the FCC Rules. These limits are designed to provide reasonable protection against harmful interference in a residential installation. This equipment generates, uses and can radiate radio frequency energy and, if not installed and used in accordance with the instructions, may cause harmful interference to radio communications. However, there is no guarantee that interference will not occur in a particular installation. If this equipment does cause harmful interference to radio or television reception, which can be determined by turning the equipment off and on, the user is encouraged to try to correct the interference by one or more of the following measures:

- Reorient or relocate the receiving antenna.
- Increase the separation between the equipment and receiver.
- Connect the equipment into an outlet on a circuit different from that to which the receiver is connected.
- Consult the dealer or an experienced radio/TV technician for help.

Modifications not expressly approved by the manufacturer could void the user's authority to operated the equipment under FCC rules.

This Device has been evaluated to comply with RF exposure requirement for general use limit in portable condition. It is safe to be used in sold condition.