

MODEL WSP-i450

(4inch Industrial Printer)

Rev. 1.0

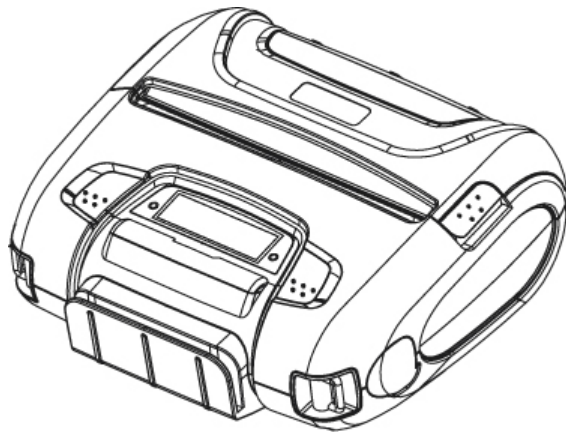

**WOOSIM SYSTEMS Inc.
#501, Daerung Technotown 3th,
448, Gasan-Dong, GeumChun-Ku,
Seoul, Korea**

Tel : +82-2-2107-3700

Fax : +82-2-2107-3707

URL: <http://www.woosim.com>

CE2200!

■ Copyright

WSP-i450 4inch Industrial printer operator's manual.

Copyright ©2009 by Woosim Systems Inc.

All rights reserved.

The information contained in this manual is the property of Woosim Systems Inc. and may not be reproduced in whole or in part without the prior written permission of Woosim Systems Inc.

■ Trademark



a registered trademark of Woosim Systems Inc.

All other trademark are the properties of their respective companies.

■ Caution

Some semiconductor devices are easily damaged by static electricity. You should turn the printer "OFF", before you connect or removed the cable on the rear side, in order to guard the printer against the static electricity.

If the printer is damaged by the static electricity, you should turn the printer "OFF"

■ Notice

The contents of this manual are subject to change without notice.

All specifications are subjected to change without notice



<http://www.woosim.com>

■ Introduction

The **WSP-i450** is the ideal solution for Mobile banking system , Retail, point of sales, Credit card Transaction, other traveling and mobile computing etc.

The general features of WSP-i450 printer are as follows:

- ▶ Pocket size 151.5×135.7×63.5mm (MSR : 151.5 X 142.5 X 63.5)
- ▶ Light weight(550g) for true mobility [standard]
- ▶ Very silent printing thru direct thermal printing method
- ▶ High speed (60mm/sec, MAX)
- ▶ High resolution(203dpi : 8dots/mm).
- ▶ UART(RS-232C or TTL), Bluetooth Ver2.1
Wireless LAN (IEEE802.11b/g) interface
- ▶ Support Magnetic Stripe Reader
- ▶ Support Graphic LCD(128×32dots) with Blue LED Backlight
- ▶ Intuitive LED's indicate Power(on/off),Error and Battery status
- ▶ Support text and graphic printing
- ▶ Easier paper roll loading by CLAMSHELL design
- ▶ One touch paper cover
- ▶ Printer door open & Paper-out sensor
- ▶ Easier maintenance with self-diagnostic.
- ▶ In field programming – Update Firmware, Download Fonts and Logos
- ▶ Compact and easy to carry around.
- ▶ Water-resistant construction.(IP54 – Certified)
- ▶ Microsoft Windows 98 /ME /2000 / XP / VISTA / 7 compatible.
- ▶ Flow control : Software (XON/XOFF)
 - ※ Hardware flow control not supported in printer.
- ▶ Free fall: 1 meter onto concrete (option 1.5 meter)
- ▶ Agency Approvals

■ Operating Precautions

Please follow the precautions below to enjoy and maintain the full performance of the printer.

▶ Using the Printer

- Be careful not to drop or bump the printer on a hard surface.
- Do not install the printer in direct sunlight or such areas.
Suitable environment for the use of the printer is as follows:
 - ◆ Operating temperature :-10°C to 50°C
 - ◆ Relative humidity : 0% to 90% (No condensation)
- Do not install the printer near devices that generate strong electromagnetic fields such as a copy machine.
- Do not open the platen cover during printing .
- Do not remove or reinstall the communication cable during printing or transmission.
- Do not touch the connectors of the communication during printing.
- Switch the POWER OFF when not in use.
- Do not use alcohol or other solvent.
- The AC adapter, the battery charger and the battery pack may become warm when in use. This is normal and is not a malfunction.
- When the battery pack is used at low temperature, the length of time the printer can be used may be shortened.

▶ Thermal Paper Handling

- Store the thermal paper in a cool, dry and dark place.
- Do not rub the paper with hard object.
- Do not leave the paper with hard object.
- Do not allow plastic film, erasers, or adhesive tape to touch the paper for long periods.
- Do not stack the thermal paper with diazo copies immediately after copying or wet-type copies.
- Do not use chemical glue.
- Always use the clean thermal paper.

■ **Note**

FCC ID : QDDWSP-I450

THIS DEVICE COMPLIES WITH PART 15 OF THE FCC RULES.

Operation is subject to the following two conditions; (1)

This device may not cause harmful interference, and (2) this device must accept any interference received,

including interference that may cause undesired operation.

CAUTION : Changes or modifications not expressly approved by the party

responsible for compliance could void the user's authority to operate the equipment.

Note: This equipment has been tested and found to comply with the limits for a Class B digital device, pursuant to part 15 of the FCC Rules. These limits are designed to provide reasonable protection against harmful interference in a residential installation. This equipment generates, uses and can radiate radio frequency energy and, if not installed and used in accordance with the instructions, may cause harmful interference to radio communications. However, there is no guarantee that interference will not occur in a particular installation. If this equipment does cause harmful interference to radio or television reception, which can be determined by turning the equipment off and on, the user is encouraged to try to correct the interference by one or more of the following measures:

- Reorient or relocate the receiving antenna.
- Increase the separation between the equipment and receiver.
- Connect the equipment into an outlet on a circuit different from that to which the receiver is connected.
- Consult the dealer or an experienced radio/TV technician for help.

Modifications not expressly approved by the manufacturer could void the user's authority to operated the equipment under FCC rules.

This Device has been evaluated to comply with RF exposure requirement for general use limit in portable condition. It is safe to be used in sold condition.

CONTENTS

1. Outline	7
1.1. Model classifications	7
1.2. Product Part Number System	7
1.3. Specifications	8
2. Setting up the printer	10
2.1. Printer & Accessories	10
2.2. Printer Features	11
2.3. Replacing paper roll	13
2.4. Power supply	14
2.4.1. Specified power supply	14
2.4.2. Installing the battery and the belt strap	14
2.4.3. Recharging the battery pack	15
2.5. Set operation mode	16
3. Interface	22
3.1. UART(RS-232C or TTL)	22
3.2. Bluetooth	23
3.3. Wireless LAN	23
4. Smart Card Module	24
4.1. General Spec	24
4.2. Communication Protocol Sequence	25
4.2.1. Regular Operation	25
4.2.2. Irregular Operation (Communication Error)	25
5. Using the printer	26
5.1. Control panel	26
5.2. The self test	27
6. Consumable Parts	28
6.1. Recommended paper	28
5.2. Printing position	28

1. Outline.

1.1. Model classifications.

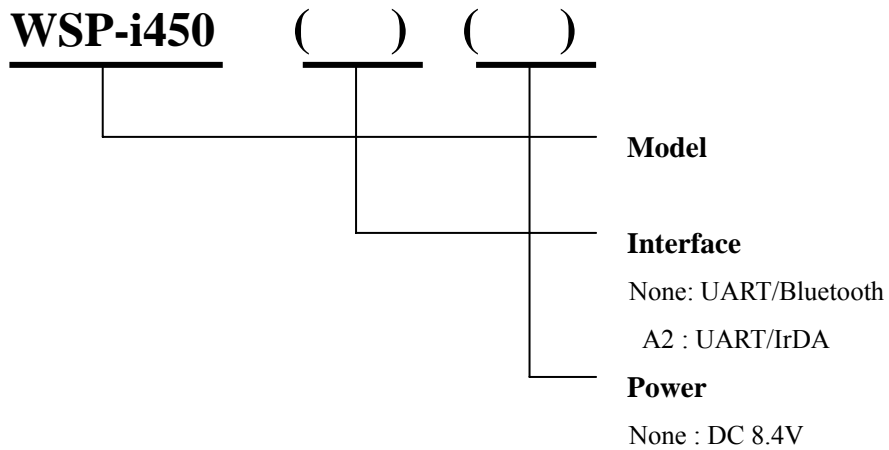

1.2. Product Part Number System.

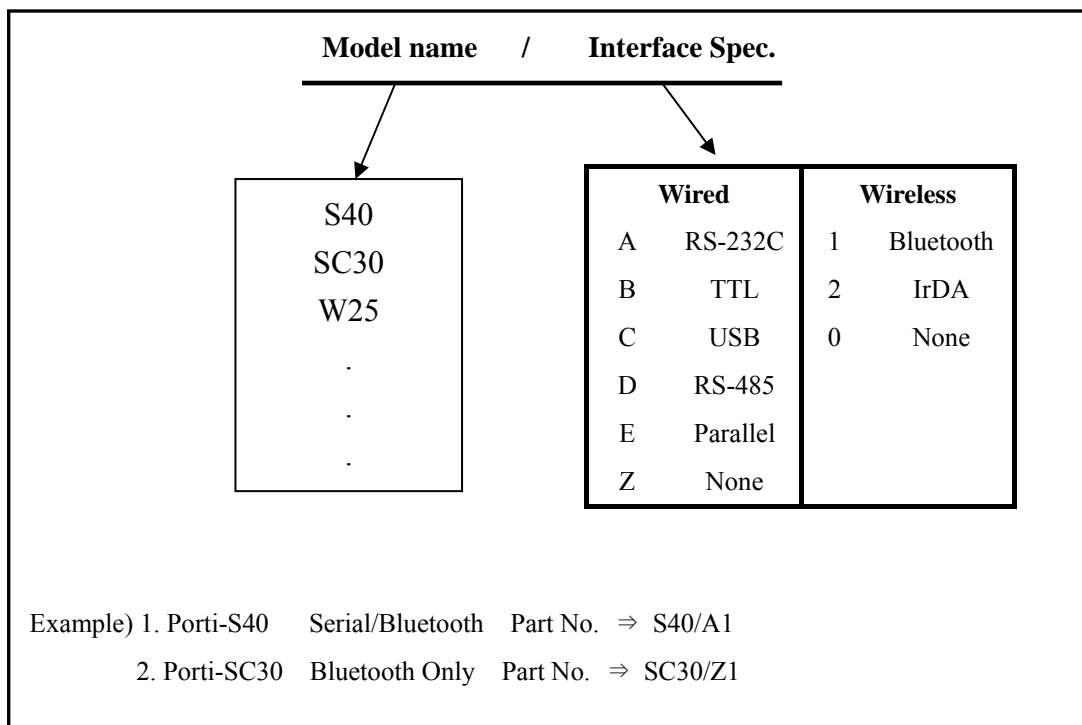

1.3. Specifications.

Item	Specifications
Print method	Direct thermal line printing
Characters per line	Eng : 92cpl (MAX)
Character size	Eng. : 9×24dots, 12×24dots Kor. : 16×24dots, [24×24dots]
Optional Characters	Simplified/Traditional Chinese, Arabic, Cyrillic, Russian, Turkish, Greek, Japanese, Persian, Latin9 and Others upon request.
Resolution	203dpi, 8 dots/mm
Print width	4-inch (104mm, 832dots)
Print speed	60mm / sec (MAX)
Dimension	151.5× 135.7 × 63.5 mm (MSR : 151.5 X 142.5 X 63.5mm)
Weight	550g (Including battery & roll paper) [standard] 556g (Including battery & roll paper) [MSR]
Interface	UART(RS-232C or TTL), Bluetooth Ver 2.1 + EDR Wireless LAN interface(IEEE802.11b/g)
Paper roll	Thermal roll paper (113mm wide, 50ø)
Barcodes	1-dimension : Code128, Code39, I2/5, Code93 UPC, EAN, KAN, JAN, CODABAR 2-dimension : PDF417, QR Code, DATA Matrix
Black mark	Support black mark detection
H/W Spec.	MCU : 32bits RISC, FLASH : 4M bytes, RAM : 8M bytes
Receive buffer size	1M bytes
MSR	ISO 7810 / 7811 / 7812 1&2&3 Track Reading
Smart Card Reader	ISO 7816 Compliant (EMV level 1 Certified) / T=0, T=1 support / 1 SAM (Security Application Module)
LCD	128 × 32 Dots FSTN (Blue LED Backlight)
Battery	Rechargeable 7.4V DC, 2,200mAh (Li-ion)
Battery duration	1 hour continuous printing

(Continue...)

Item	Specifications	
Battery charger	Input (100~250V AC, 50~60Hz) Output(8.4VDC/0.8A), 4hours full charge time	
Environment conditions	Temperature	-10°C ~ 50°C (operating) -10°C ~ 70°C (storage)
	Humidity	30% - 80% (operating) 0% - 95% (storage)
MCBF(Mean Cycle Between Failure)	Mechanical	37,000,000 lines
	Head	Approximately 50 Km

< Table 1 >

2. Setting up the printer.

2.1. Printer & Accessories

Your printer box should include these items. If any items are damaged or missing, please contact your dealer for assistance.



WSP-i450

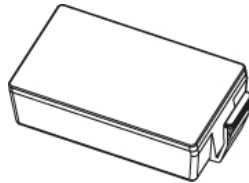

Battery pack

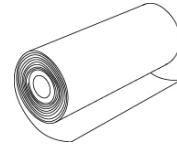

Thermal roll paper

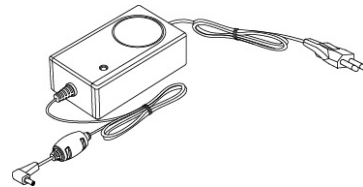

Battery charger adaptor

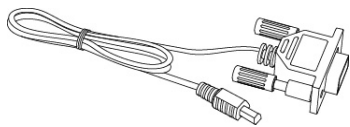

Communication cable



Shoulder band

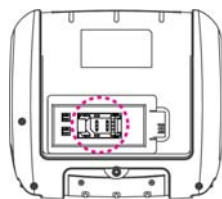

SAM Connector



Smart Card



MSR

2.2. Printer Features

► Part Name

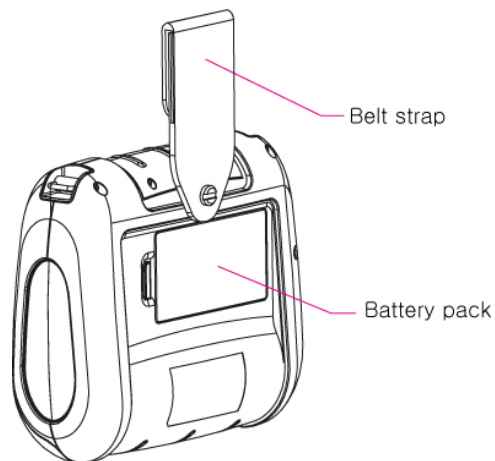
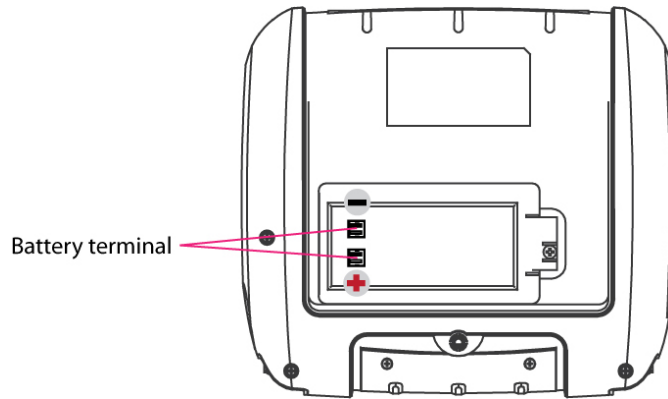
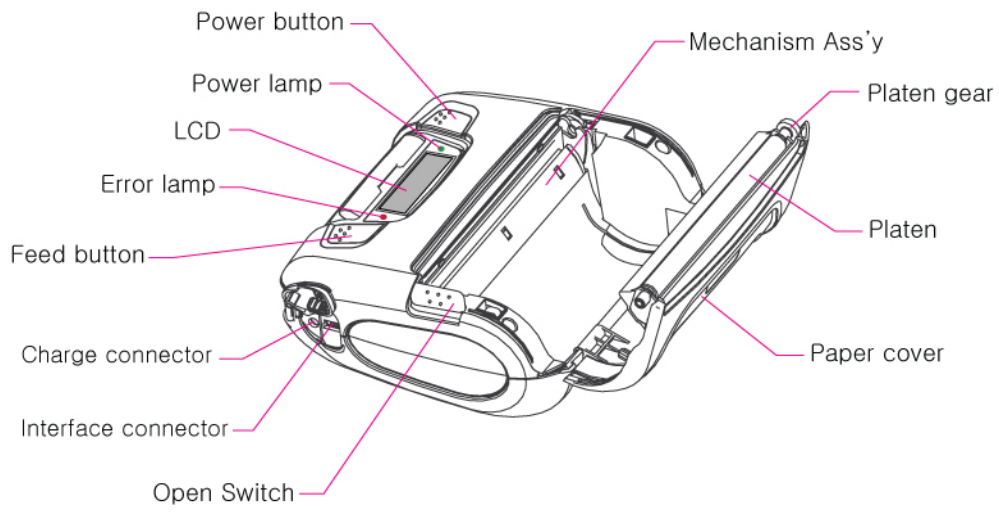

► Dimensions

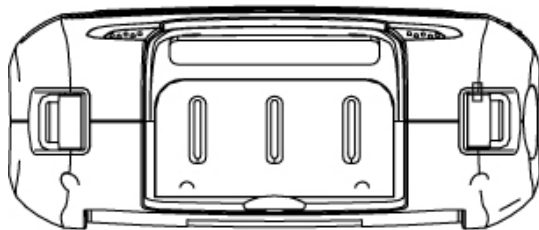
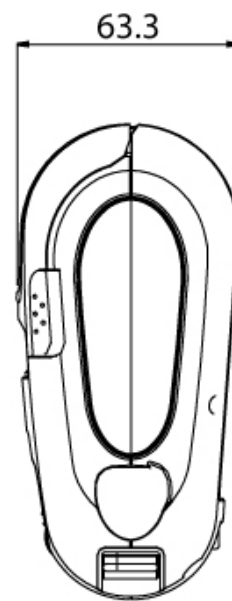
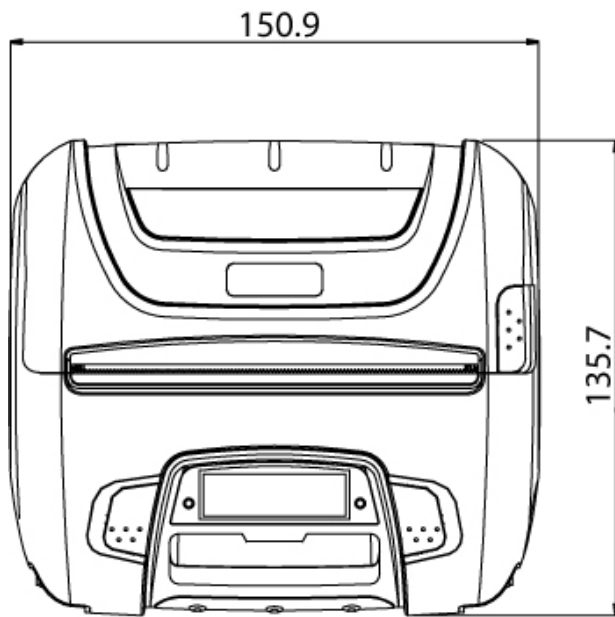
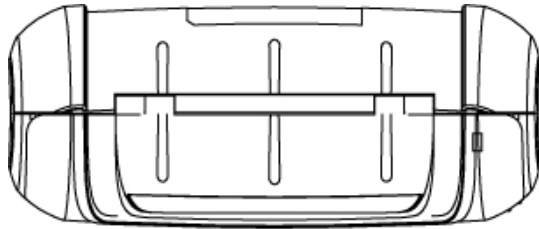

2.3. Replacing paper roll.

Note : Be sure to use paper rolls that meet the specifications.

Do not use paper rolls that have the paper glued to the core because the printer can not detect the paper end correctly.

1. Make sure that the printer is not receiving data; otherwise, data may be lost.
2. Open the paper cover by placing your fingers under the paper cover lock and pull a paper cover lock open.

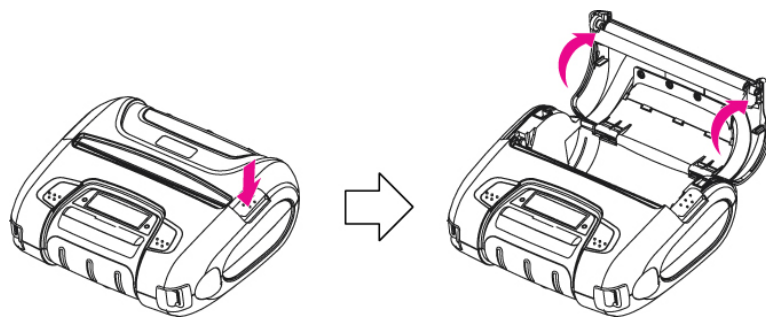

3. Insert a new paper roll as shown.

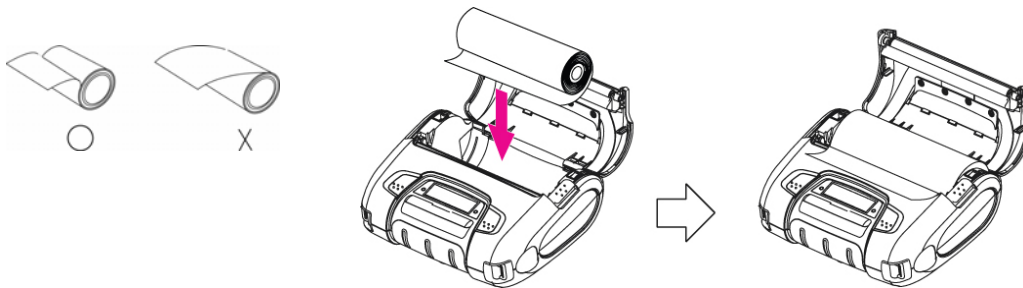

4. Tear the excess paper off using the edge of paper door as a tear bar.

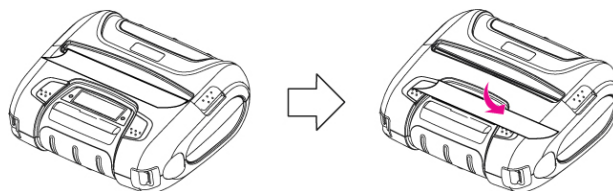

2.4. Power supply

2.4.1. Specified power supply.

The following specification is requested for Power supply.

Battery Charger : DC 8.4V/0.8A

Avoid using power supply which its power capacity of power current is extremely high.

2.4.2. Installing the battery and the belt strap

NOTE :

- Before installing or removing the battery pack, ensure the printer is OFF.
- If the printer is not used for long period of time, remove the battery pack from the printer.

** BATTERY **

① To install battery pack, proceed as follows:

- Insert the Battery pack in the direction of the arrow.

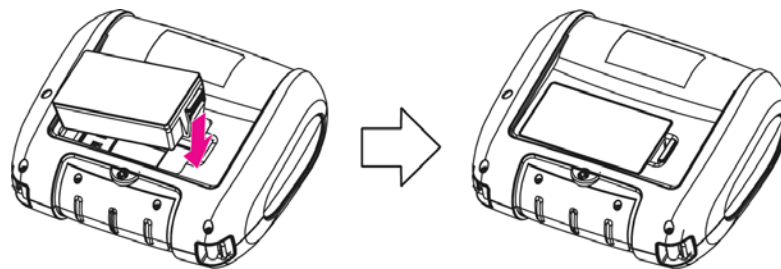

② Reverse the order to remove the battery pack.

** BELT STRAP **

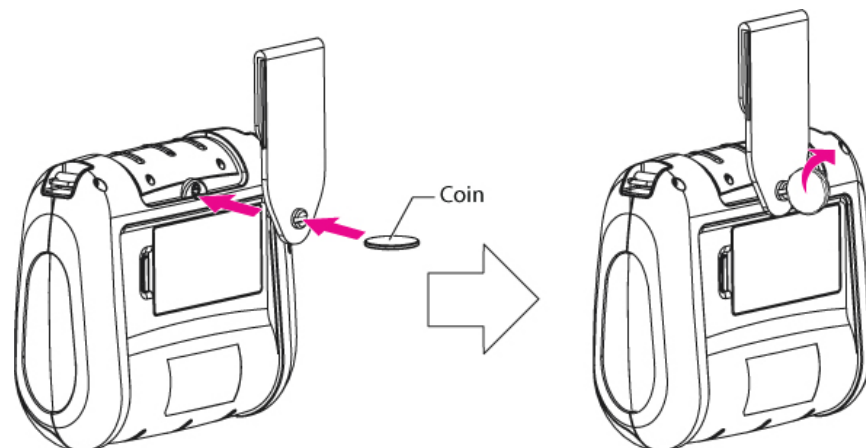

2.4.3. Recharging the battery pack

For recharging the battery pack, install the battery pack in the printer.
Insert the Battery Charger to the charge connector of the printer.

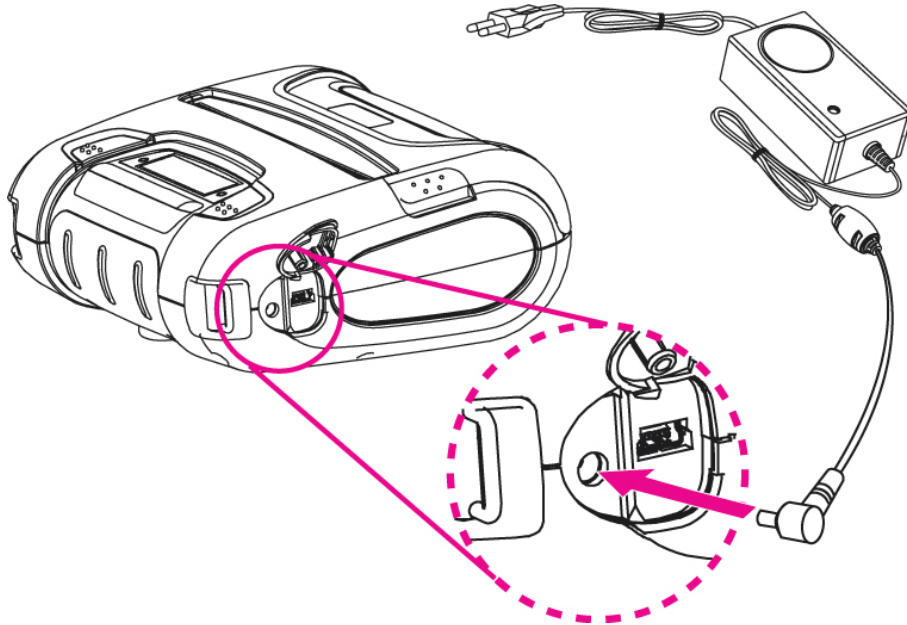

- NOTE :**
- While charging the printer, turn off the printer power.
 - Do not remove the battery during charging.
 - The battery is consumable parts and when purchasing, compared to the use hour is gradually decreases. (Warranty 6 month)
 - If the printer is not used for a long time, unplug the power cord from the printer and outlet.
 - The recharging time depends on the voltage level and ambient temperature of the battery. Normally, it takes about 4 to 5 hours to recharge a battery pack.
 - You must use only the supplied adapter.
 - Red Lamp : charging the battery.
Green Lamp: charging is finished.

2.5. Set operation mode.

Change the mode and option using the mode Code.

- **MODE button** : changing Printer MODE status. (Error Lamp)
- **FEED button** : changing OPTION status.

[Example] The defaults of the printer are :

UART / 9600 bps / 8 data bit / No parity / 1 stop bit / Density low / Quality low
/ Mark use / Sensor low / Power down 5 minute

If a user wants to modify the defaults with

Bluetooth / 57,600 bps / 7 data bit / Odd parity / 2 stop bit / Density high / Quality high
/ Mark no use / Sensor medium1 / Power down no use

- ▶ Press **MODE Button** and **FEED button** during the **Error Lamp** flickers 5 times.
 - You will see present **COMMUNICATION** mode in the LCD.
 - Press the **MODE Button** twice.
 - And then, interface mode has set to **Bluetooth** mode.
- ▶ When you press **FEED button** once.
 - You will see present **BAUD RATE** mode in the LCD.
 - Press **MODE Button** 3 times.
 - And then, baudrate has set to **57,600 bps**.
- ▶ When you press **FEED button** once.
 - You will see present **DATA BIT** mode in the LCD.
 - Press **MODE Button** once.
 - And then Data Bit has set to **7 data bit**.
- ▶ When you press **FEED button** once.
 - You will see present **PARITY** mode in the LCD.
 - Press **MODE Button** once.
 - And then the Parity bit has set to **Odd parity bit**.
- ▶ When you press **FEED button** once.
 - You will see present **STOP BIT** mode in the LCD.
 - Press **MODE Button** once.
 - And then the density has set to **2 stop bit**.

- ▶ When you press **FEED button** once.
 - You will see present **DENSITY** mode in the LCD.
 - Press **MODE Button** twice.
And then the density has set to **Density high**.
- ▶ When you press **FEED button** once.
 - You will see present **Quality** mode in the LCD.
 - Press **MODE Button** once.
And then the quality has set to **Quality high**.
- ▶ When you press **FEED button** once.
 - You will see present **MARK** mode in the LCD.
 - Press **MODE Button** once.
And then the mark has set to **Mark no use**.
- ▶ When you press **FEED button** once.
 - You will see present **SENSOR** mode in the LCD.
 - Press **MODE Button** once.
And then the sensor has set to **Sensor medium1**.
- ▶ When you press **FEED button** once.
 - You will see present **PWDN** mode in the LCD.
 - Press **MODE Button** once.
And then the Power down has set to **Power down no use**.

If all the mode have set, press the **MODE Button** and the **FEED Button** at the same time after then release the buttons at the same time.

The printer will print out the mode status which has modified.

**(Bluetooth / 57600 bps / 7 data bit / Odd parity / 2 stop bit / Density high / Quality high
Mark no use / Sensor medium1 / Power down no use)**

If the status is not correct, please try it again according to the procedure.

* Bluetooth Version

	POWER Lamp (Green)	ERROR Lamp (Red)	Option
Communication Port	1	1	UART(RS-232C)
		2	Protocol UART(RS-232C)
		3	Bluetooth
		4	Protocol Bluetooth
Baud Rate	2	1	9600 bps
		2	19200 bps
		3	38400 bps
		4	57600 bps
		5	115200 bps
Data Bit	3	1	7 Data bit
		2	8 Data bit
Parity Bit	4	1	No Parity
		2	Odd Parity
		3	Even Parity
Stop Bit	5	1	1 Stop bit
		2	2 Stop bit
Density	6	1	Density Low
		2	Density Medium
		3	Density High
Quality	7	1	Low
		2	High

(Continue...)

	POWER Lamp (Green)	ERROR Lamp (Red)	Option
Mark	8	1	No use
		2	Use
Sensor	9	1	Low
		2	Medium1
		3	Medium2
		4	High
Power Down	10	1	No use
		2	1 minute
		3	2 minute
		4	3 minute
		5	4 minute
		6	5 minute

< Table 2 >

* WLAN Version

	POWER Lamp (Green)	ERROR Lamp (Red)	Option
Communication Port	1	1	UART(RS-232C)
		2	Protocol UART(RS-232C)
		3	WLAN
		4	Protocol WLAN
Baud Rate	2	1	9600 bps
		2	19200 bps
		3	38400 bps
		4	57600 bps
		5	115200 bps
Data Bit	3	1	7 Data bit
		2	8 Data bit
Parity Bit	4	1	No Parity
		2	Odd Parity
		3	Even Parity
Stop Bit	5	1	1 Stop bit
		2	2 Stop bit
Density	6	1	Density Low
		2	Density Medium
		3	Density High
Quality	7	1	Low
		2	High

(Continue...)

	POWER Lamp (Green)	ERROR Lamp (Red)	Option
Mark	8	1	No use
		2	Use
Sensor	9	1	Low
		2	Medium1
		3	Medium2
		4	High
Power Down	10	1	No use
		2	1 minute
		3	2 minute
		4	3 minute
		5	4 minute
		6	5 minute

< Table 3 >

3. Interface.

3.1. UART(RS-232C or TTL)

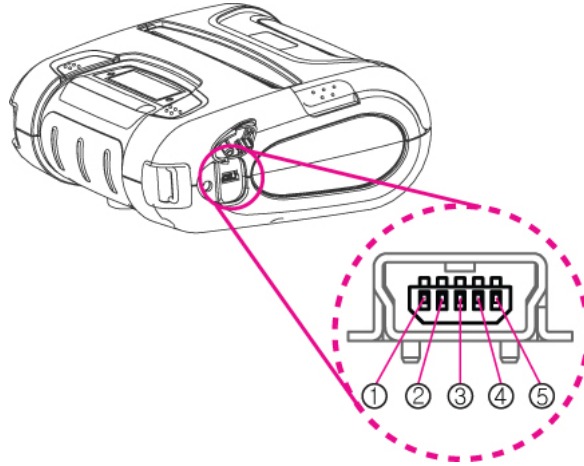

Pin No.	Name	Direction	Function
1	TxD	Output	Transmit Data
2	RxD	Input	Receive Data
3	CD	-	Cable Detector
4	NC.	-	-
5	GND	-	Ground

The WSP-i450 printer has a UART(RS-232C or TTL) interface and is connected by means of a 5 pin mini USB socket. In the following table, the signals present on the Mini- USB socket are listed:

NOTE : ● When data receiving, when it removes the communication cable, it loses a data.

3.2. Bluetooth

Category	Specification
Bluetooth Spec.	Bluetooth Ver2.1 / Class2 (10m)
Frequency Range	2.4GHz ISM BAND (2402 ~ 2480 MHz)
RF Power	Below 10 dBm
Modulation method	GFSK
Oscillation method	PLL
Data Transmission Rate	57600bps Fixed.
Data bit	8 Data bit Fixed.
Parity bit	No parity Fixed.
Stop bit	1 Stop bit Fixed.

3.3. Wireless LAN

Category	Specification	
Interface	Network	IEEE802.11b/g
RF Power	Below 10 dBm	
Modulation method	CCK, OFDM	
Oscillation method	PLL	
Protocol	TCP, UDP, IP, ICMP, ARP, DHCP, PPPoE DNS lookup, DDNS(Dynamic DNS), WEP	
Communication Mode	T2S	TCP Server Mode
	COD	TCP Client Mode
	ATC	TCP Server / Client (AT command emulation)
	U2S	UDP

4. Smart Card Module

4.1. General Spec.

- ▶ Contact Smart Card Reader Module for ISO/IEC-7816
- ▶ Support Asynchronous Protocol T=0,T=1
- ▶ Smart Card Connection
 - Short Circuit Current Limitation
 - 6KV ESD Protection on whole Smart Card Interface
 - Connector : Friction Type with Smart Card presence detection
- ▶ 1 SAM (Security Application Module)
- ▶ EMV Level 1 Certified

4.2. Communication Protocol Sequence

4.2.1. Regular Operation

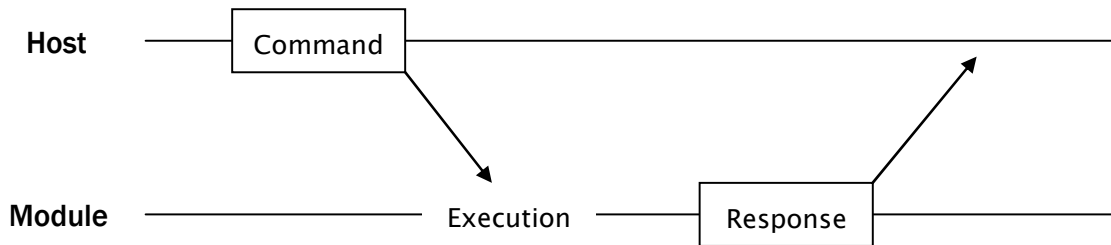

4.2.2. Irregular Operation (Communication Error)

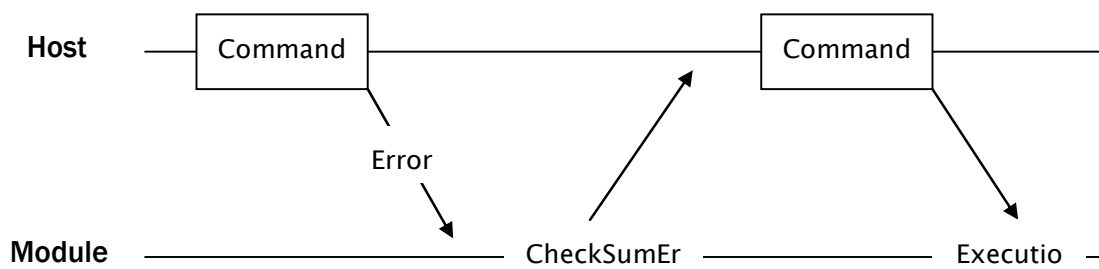
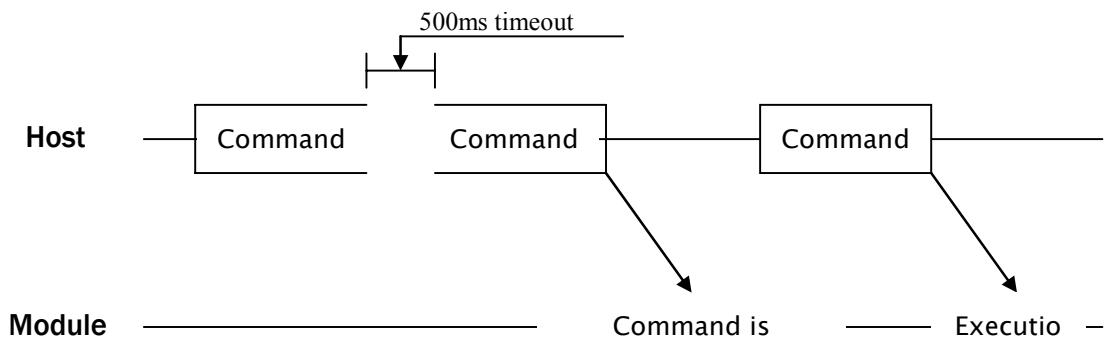

5. Using the printer.

5.1. Control panel.

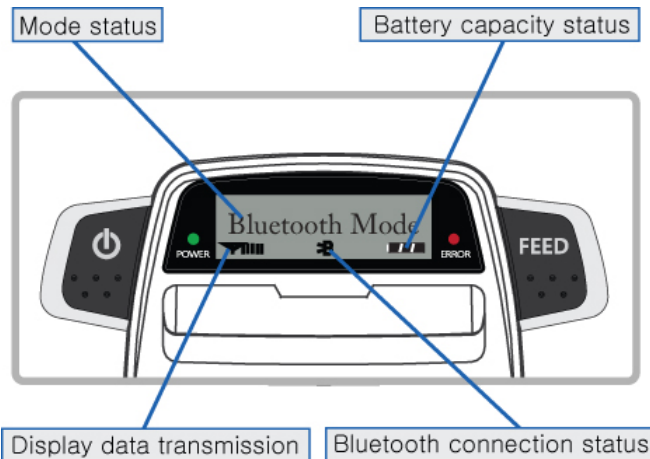

► Button

- FEED Button :

When the printer is on, paper can be feed manually by pressing and holding the FEED button for more than one second.

- POWER Button :

- ① When of 5 or more seconds presses and power comes to on or off.
- ② After pressing the POWER and the FEED button simultaneously, if the ERROR lamp 5 turn signals POWER button is converted with MODE functions.

MODE functions are for use to change communication mode.

(Refer to **2.5. Set operation mode** for details about mode conversion)

► Panel lamp

-POWER (Green) : Printer is ON and ready to receive data.

-ERROR (Red) : Indicated a fault condition or a printer error.

(i.e : no paper, paper cover opened. etc.)

5.2. The self test.

The self test procedure will check most of the printer functions.

For self test, turn on the power while holding down the FEED Button.

The Self-Test checks the following :

- 1) Make sure paper roll has been installed properly.
- 2) The Self-Test prints the current printer status, which provides the control ROM version and the communication method setting.
- 3) After printing the current printer status, Self-Test will print a pattern using the built-in character set.
- 4) The Self-Test automatically ends.

The printer is ready to receive data as soon as it completed the self test.

6. Consumable Parts.

6.1. Recommended paper.

Type	: Thermal Paper
Paper width	: 104mm
Paper thickness	: $60 \pm 5 \mu\text{m}$
Outer diameter	: $\text{Ø}50\text{mm}$ or less
Recording side	: Outside of roll



Cautions

1. Do not paste the paper to the core. And the roll paper which has Near end mark printing on its near end is recommended.
2. Chemicals or oil may change the color of paper, or printed Characters may fade.
3. Change of paper color starts from approx 70°C .
Pay attention to heat, humidity and sun light.
4. Color of paper may be changed by being scratched by nail or hard metal, etc

5.2. Printing position.

