

Operator's Manual

MODEL **WSP-R242**

(2inch Mobile Printer)

Rev. 1.0



WOOSIM SYSTEMS Inc.

(#501, Daerung Technotown 3th)

115, Gasan digital 2-ro, Geumcheon-gu,

Seoul, 153-772 Rep. of KOREA

Tel : +82-2-2107-3700

Fax : +82-2-2107-3707

URL: <http://www.woosim.com>

All specifications are subjected to change without notice



<http://www.woosim.com>

■ Copyright

WSP-R242 2inch mobile printer operator's manual.

Copyright ©2015 by Woosim Systems Inc.

All rights reserved.

The information contained in this manual is the property of Woosim Systems Inc.

And may not be reproduced in whole or in part without the prior written permission of Woosim Systems Inc.

■ Trademark



a registered trademark of Woosim Systems Inc.

All other trademark are the properties of their respective companies.

■ Caution

Some semiconductor devices are easily damaged by static electricity. You should turn the printer "OFF", before you connect or removed the cable on the rear side, in order to guard the printer against the static electricity.

If the printer is damaged by the static electricity, you should turn the printer "OFF"

■ Notice

The contents of this manual are subject to change without notice.

■ Introduction

The **WSP-R242** is the ideal solution for Mobile banking system , Retail, point of sales, Credit card Transaction, other traveling and mobile computing etc.

The general features of **WSP-R242** printer are as follows:

- ▶ Compact size (79.2 x 123 x 45.6mm)
- ▶ Light weight(231g) for true mobility
- ▶ Very silent printing thru direct thermal printing method
- ▶ High speed (100mm/sec, MAX)
- ▶ High resolution(203dpi : 8dots/mm).
- ▶ USB, Bluetooth Ver3.0 interface
- ▶ Support Graphic LCD(128×32dots) with Blue LED Backlight
- ▶ Support Magnetic Stripe Reader [option]
- ▶ Support Smart Card Reader [option]
- ▶ Support text and graphic printing
- ▶ Easier paper roll loading by CLAMSHELL design
- ▶ One touch paper cover
- ▶ Printer door open & Paper-out sensor
- ▶ Easier maintenance with self-diagnostic.
- ▶ In field programming – Update Firmware, Download Fonts and Logos
- ▶ Microsoft Windows XP/VISTA/7/8/CE, Linux, Android compatible.
- ▶ Flow control : Software (XON/XOFF)
 - ※ Hardware flow control not supported in printer.
- ▶ Agency Approvals



▣ Operating Precautions

Please follow the precautions below to enjoy and maintain the full performance of the printer.

▶ Using the Printer

- Be careful not to drop or bump the printer on a hard surface.
- Do not install the printer in direct sunlight or such areas.
Suitable environment for the use of the printer is as follows:
 - ◆ Operating temperature : -10°C to 50°C
 - ◆ Relative humidity : 30% to 80%
- Do not install the printer near devices that generate strong electromagnetic fields such as a copy machine.
- Do not open the platen cover during printing .
- Do not remove or reinstall the communication cable during printing or transmission.
- Do not touch the connectors of the communication during printing.
- Switch the POWER OFF when not in use.
- Do not use other solvent.
- The AC adapter, the battery charger and the battery pack may become warm when in use. This is normal and is not a malfunction.
- When the battery pack is used at low temperature, the length of time the printer can be used may be shortened.

▶ Thermal Paper Handling

- Store the thermal paper in a cool, dry and dark place.
- Do not rub the paper with hard object.
- Do not leave the paper with hard object.
- Do not allow plastic film, erasers, or adhesive tape to touch the paper for long periods.
- Do not stack the thermal paper with diazo copies immediately after copying or wet-type copies.
- Do not use chemical glue.
- Always use the clean thermal paper.

**Federal Communications Commission
Radio Frequency Interference Statement**

FCC ID : QDDWSP-R242

This device complies with Part 15 of the FCC Rules. Operation is subject to the following two conditions: (1) This device may not cause harmful interference, and (2) this device must accept any interference received, including interference that may cause undesired operation.

CAUTION: Changes or modifications not expressly approved by the party responsible for compliance could void the user's authority to operate the equipment.

Note: This equipment has been tested and found to comply with the limits for a Class B digital device, pursuant to part 15 of the FCC Rules. These limits are designed to provide reasonable protection against harmful interference in a residential installation. This equipment generates, uses and can radiate radio frequency energy and, if not installed and used in accordance with the instructions, may cause harmful interference to radio communications. However, there is no guarantee that interference will not occur in a particular installation. If this equipment does cause harmful interference to radio or television reception, which can be determined by turning the equipment off and on, the user is encouraged to try to correct the interference by one or more of the following measures:

- Reorient or relocate the receiving antenna.
- Increase the separation between the equipment and receiver.
- Connect the equipment into an outlet on a circuit different from that to which the receiver is connected.
- Consult the dealer or an experienced radio/TV technician for help.

Modifications not expressly approved by the manufacturer could void the user's authority to operate the equipment under FCC rules.

This Device has been evaluated to comply with RF exposure requirement for general use limit in portable condition. It is safe to be used in sold condition.

CE WARNING

- Changes and modifications not expressly approved by the party responsible for compliance could void the user's authority to operate the equipment.
- It is desirable that it be installed and operated with at least 20cm or more between the radiator and person's body(excluding extremities hand, wrists, feet, and ankles)

CONTENTS

- 1. Outline.8**
 - 1.1. Model classifications.8
 - 1.2 Product Part Number System8
 - 1.3. Specifications.9
- 2. Setting up the printer.....11**
 - 2.1. Printer & Accessories 11
 - 2.2. Printer Features 12
 - 2.3. Dimensions..... 13
 - 2.4. Replacing paper roll..... 14
 - 2.5. Power supply..... 15
 - 2.5.1. Specified power supply..... 15
 - 2.5.2. Installing the battery 15
 - 2.5.3. Recharging the battery pack..... 16
 - 2.6. Set operation mode 17
 - 2.6.1. GAP/HOLE SENSOR SETTING 19
 - 2.7. Memory switch table..... 20
- 3. Interface..... 21**
 - 3.1. USB 21
 - 3.2. Bluetooth 21
 - 3.3. Magnetic Card Reading 22
- 4. Smart Card Reader Module..... 23**
 - 4.1. General Spec. 23
 - 4.2. Inserting the SAM card..... 23
 - 4.3. Inserting the IC card..... 24
 - 4.4. Communication Protocol Sequence 25
 - 4.4.1. Regular Operation..... 25
 - 4.4.2. Irregular Operation (Communication Error) 25
- 5. Using the printer..... 26**
 - 5.1. Control panel. 26

5.2. The self test.....27

5.3. Using the Belt clip27

6. Consumable Parts28

6.1. Recommended paper28

6.2. Printing position.....28

7. Revision History29

1. Outline.

1.1. Model classifications.

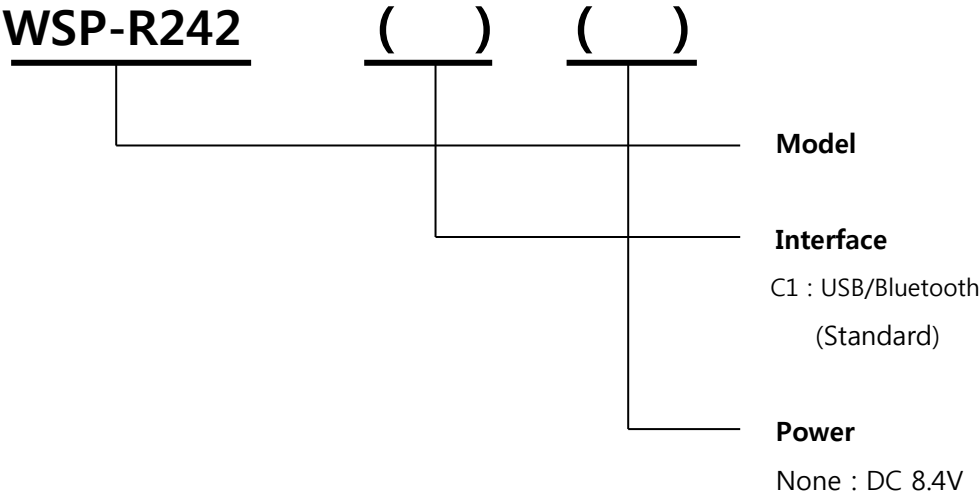

1.2 Product Part Number System

Model name / Interface Spec.

S40 SC30 W25 . . .	<table border="1" style="width: 100%; border-collapse: collapse;"> <thead> <tr> <th colspan="2">Wired</th> <th colspan="2">Wireless</th> </tr> </thead> <tbody> <tr> <td>A</td> <td>RS-232C</td> <td>1</td> <td>Bluetooth</td> </tr> <tr> <td>B</td> <td>TTL</td> <td>2</td> <td>IrDA</td> </tr> <tr> <td>C</td> <td>USB</td> <td>3</td> <td>Wireless LAN</td> </tr> <tr> <td>D</td> <td>RS-485</td> <td>0</td> <td>None</td> </tr> <tr> <td>E</td> <td>Parallel</td> <td></td> <td></td> </tr> <tr> <td>Z</td> <td>None</td> <td></td> <td></td> </tr> </tbody> </table>	Wired		Wireless		A	RS-232C	1	Bluetooth	B	TTL	2	IrDA	C	USB	3	Wireless LAN	D	RS-485	0	None	E	Parallel			Z	None		
Wired		Wireless																											
A	RS-232C	1	Bluetooth																										
B	TTL	2	IrDA																										
C	USB	3	Wireless LAN																										
D	RS-485	0	None																										
E	Parallel																												
Z	None																												

Example) 1. Porti-S40 Serial/Bluetooth Part No. ⇒ S40/A1
 2. Porti-SC30 Bluetooth Only Part No. ⇒ SC30/Z1

Note) The above table is the interface format which is supported.
 But some of the interfaces are not supported according to the product and please contact us, if you have any questions regarding the interface.

1.3. Specifications.

Item	Specifications
Print method	Direct thermal line printing
Character size	- Font Size A: 12X24 / Font Size B : 9X24 / Font Size C : 8X16 - KOR : 24X24(16X24) / CHN, JPN : 24X24
Characters per line	- Font A : 32cpl / Font B : 42cpl / Font C : 48cpl - KOR : 16cpl(24) / CHN, JPN : 16cpl
Optional Characters	Alphanumeric:95, Extended Graphics:128X50 pages, International:10, Simplified/Traditional Chinese, Japanese, Korean
Resolution	203dpi, 8dots/mm
Print width	2-inch (48mm, 384dots)
Print speed	100mm / sec (MAX)
Dimension	79.2 x 123 x 45.6mm
Weight (w/o paper)	231g
Interface	USB, Bluetooth Ver3.0
Paper roll	Thermal roll paper (58mm wide, 40ø)
Barcodes	1-dimension : UPC-A, UPC-E, EAN-8, EAN-13, CODE-39, CODE-93, CODE-128, ITF, CODABAR 2-dimension : PDF417, Micro PDF417, Truncated PDF417, QR-CODE, DATA Matrix, Maxicode Etc :GS1 databar
Driver	Microsoft Windows XP/VISTA/7/8/CE, Linux, Android compatible
H/W Spec	MCU : RX-32bit, RAM : 128M bit, FLASH : 64M bit
Receive buffer size	1M bytes
Sensor	Support Cover open, Paper, Label
LCD	128×32 Dots FSTN (Blue LED Backlight)
MSR	Triple tracks (1&2&3 Tracks Reading) *Supports 3DES & AES encryption
Smart Card Reader [option]	ISO 7816 Compliant [EMV level 1 Certified] / T=0, T=1 support / 2 SAM (Security Application Module)

(Continue...)

Item	Specifications	
Battery	Rechargeable 7.4V DC, 1100mAh (Li-ion)	
Battery duration	1 hour continuous printing	
Battery charger	Input (100~250V AC, 50~60Hz) Output(8.4VDC/0.8A), 4hours full charge time	
Environment conditions	Temperature	-10°C ~ 50°C (operating) -10°C ~ 70°C (storage)
	Humidity	30% - 80% (operating) 10% - 90% (storage)
MCBF (Mean Cycle Between Failure)	Head	Approximately 100Km

< Table 1 >

2. Setting up the printer.

2.1. Printer & Accessories

Your printer box should include these items. If any items are damaged or missing, please contact your dealer for assistance.



WSP-R242



Communication cable

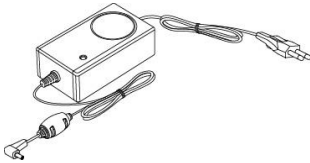

Battery charger adaptor



Battery Pack



Thermal roll paper



Belt clip

▼ **OPTIONAL**



Smart Card Reader

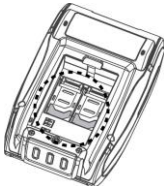

2 SAM

2.2. Printer Features

► Part Name

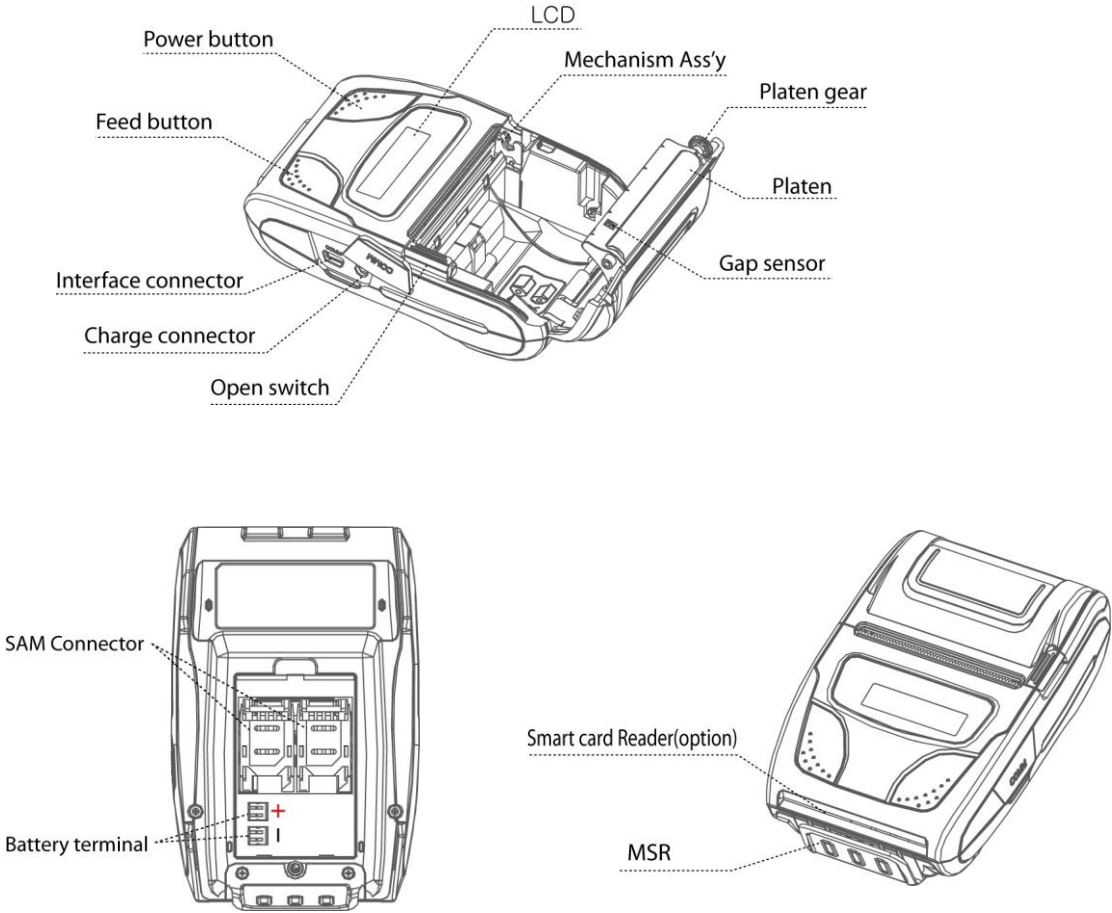

2.3. Dimensions

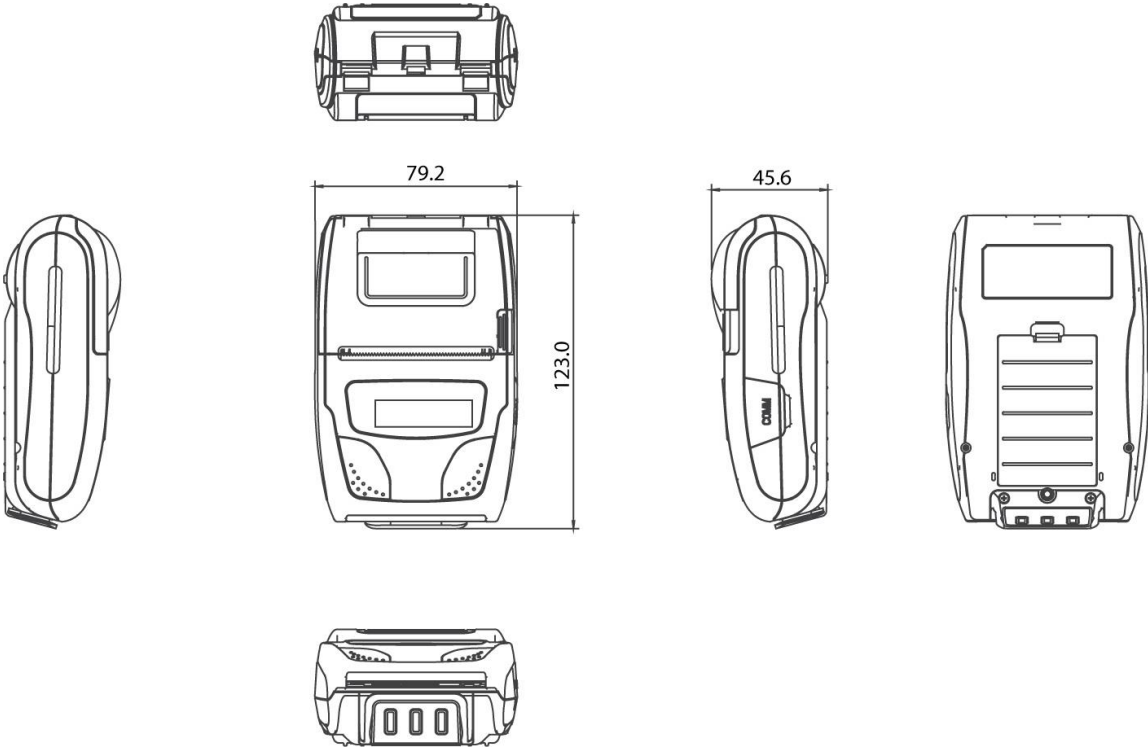

2.4. Replacing paper roll.

Note : Be sure to use paper rolls that meet the specifications.

Do not use paper rolls that have the paper glued to the core because the printer can not detect the paper end correctly.

1. Make sure that the printer is not receiving data; otherwise, data may be lost.
2. Open the paper cover as the "One-Touch" way by pressing the button in the arrow direction like the picture.

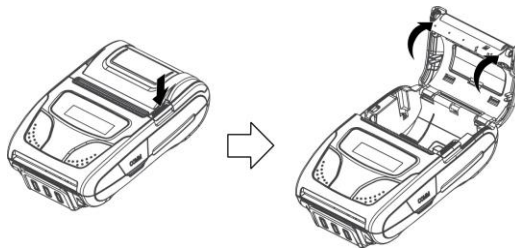

3. Insert a new paper roll as shown.

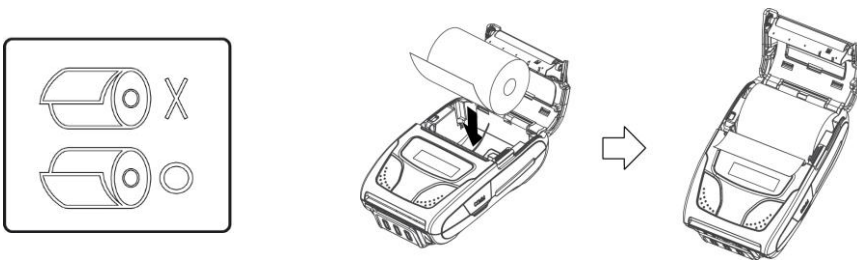

4. Tear the excess paper off using the edge of paper door as a tear bar.

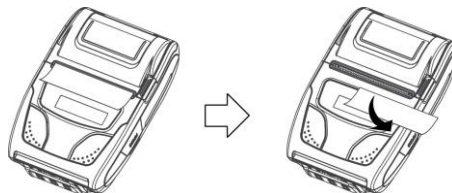

2.5. Power supply

2.5.1. Specified power supply

The following specification is requested for Power supply.

Battery Charger : DC 8.4V/0.8A

Avoid using power supply which its power capacity of power current is extremely high.

2.5.2. Installing the battery

- NOTE :**
- Before installing or removing the battery pack, ensure the printer is OFF.
 - If the printer is not used for long period of time, remove the battery pack from the printer.

① To install Battery Pack, proceed as follows:

-Insert the Battery Pack in the direction of the arrow.

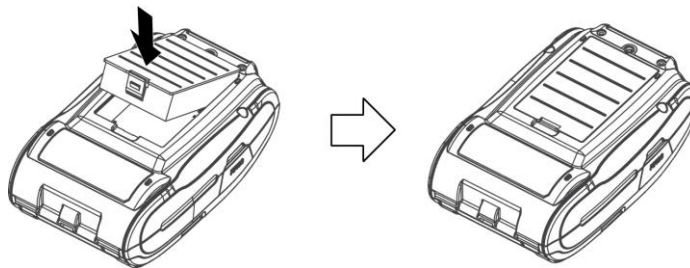

2.5.3. Recharging the battery pack

For recharging the battery pack, install the battery pack in the printer.
Insert the Battery Charger to the charge connector of the **printer**.

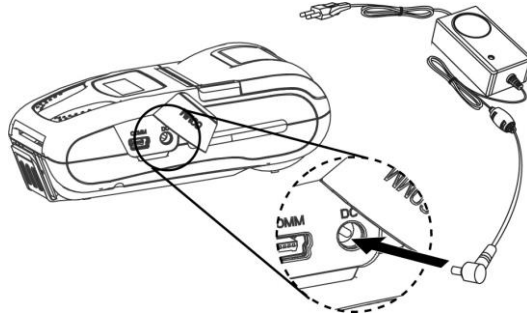

- NOTE :**
- While charging the printer, turn off the printer power.
 - Do not remove the battery during charging.
 - The battery is consumable parts and when purchasing, compared to the use hour is gradually decreases. (Warranty 6 month)
 - If the printer is not used for a long time, unplug the power cord from the printer and outlet.
 - The recharging time depends on the voltage level and ambient temperature of the battery. Normally, it takes about 4 to 5 hours to recharge a battery pack.
 - You must use only the supplied adapter.
 - Red Lamp : charging the battery.
Green Lamp : charging is finished.

2.6. Set operation mode

In keeping on pressing the Feed and Power button simultaneously until after the **LCD Backlight(blue)** blinks 5 times, the printer comes out at the circumstance to change the printer mode. (refer Table 2)

- **FEED button** : changing Printer MODE status.
- **POWER button** : changing OPTION status.

*Note

No additional mode settings are required to connect Android or iOS devices.

** If you want to change the Bluetooth Mode of printer, you need to disconnect the Bluetooth function of the current paired Smartphone.

** Methods :

1. Turn off the Bluetooth function of the current paired Smartphone.
(Bluetooth ICON in LCD is disappeared.)
2. Change the printer mode.
(Additionally, we want to recommend you to rest(OFF→ON) the printer and change mode.)

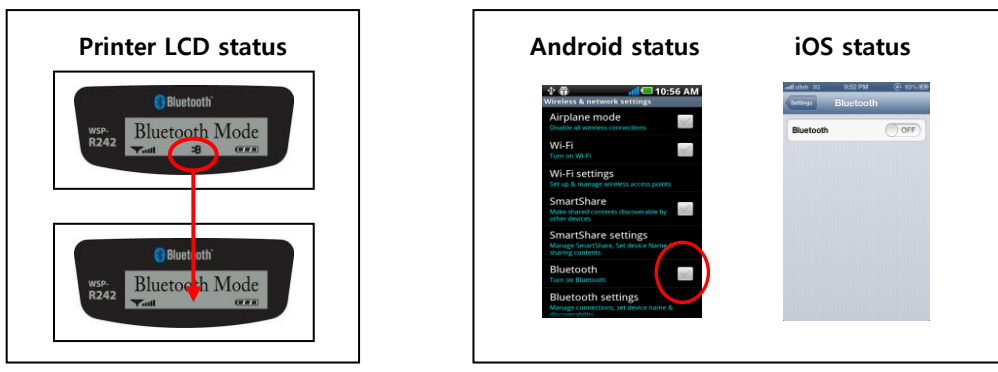

[Example] The defaults of the printer are :

USB / Density Low / Mark No Use / Sensor High / PWDN 5 min slp

If a user wants to modify the defaults with

Bluetooth / Density High / Mark Use / Sensor Low / PWDN No Use

- ▶ Press FEED & POWER Button during the **LCD backlight** flickers 5 times.
 - You will see present **COMMUNICATION** mode in the LCD. (USB)
 - Press the **POWER Button** twice. And then, interface mode has set to **Bluetooth** mode.
- ▶ When you press **FEED button** once.
 - You will see present **DENSITY** mode in the LCD. (Density low)
 - Press **POWER Button** twice. And then the density has set to **Density high**.
- ▶ When you press **FEED button** once.
 - You will see present **MARK** mode in the LCD. (No Use)
 - Press **POWER Button** once. And then the mark has set to **Mark Use**.
- ▶ When you press **FEED button** once.
 - You will see present **SENSOR** mode in the LCD. (High)
 - Press **POWER Button** once. And then the sensor has set to **Sensor Low**.
- ▶ When you press **FEED button** once.
 - You will see present **PWDN** mode in the LCD. (5 min slp)
 - Press **POWER Button** six times. And then the Power down has set to **PWDN No Use**.

If all the mode have set, press the **POWER Button** and the **FEED Button** at the same time. After then release the buttons at the same time.

Bluetooth / Density High / Mark Use / Sensor Low / PWDN No Use

2.6.1. GAP/HOLE SENSOR SETTING

1. Set Mark as GAP / HOLE on mode setting.
2. If feed button keeps being pressed during self "SENSOR SETTING" appears on LCD window and paper keeps coming out "SENSOR SETTING".
3. If feed button is not pressed after printing more than 3 pages of label
4. Setting is completed as Green and Red LED flash and "COMPLETE" appears on LCD window.

** Caution : Sensor setting stops if the feed button is not pressed during self test.

2.7. Memory switch table

Mode		Option	Etc.	Mode		Option	Etc.
1	Communi- cation Port	1	USB	5	Power Down	1	No use
		2	USB(Pro)			2	1min Sleep
		3	Bluetooth			3	2min Sleep
		4	Bluetooth(Pro)			4	3min Sleep
		5	Bluetooth(iAP)			V	5
2	Density	1	Low			6	5min Sleep
		2	Medium			7	1min Off
		3	High			8	2min Off
3	Mark	1	No use			9	3min Off
		2	Use			10	4min Off
		3	Gap / Hole			V	11
		4	Back	V			
4	Sensor sensitivity	1	Low				
		2	Medium1				
		3	Medium2				
		4	High				

< Table 2 >

Notice : Bluetooth(iAP) is the mode which is used in iPod, iPhone and iPad Whole aspect.
 Etc. (V): no function due to the specification of the product.

3. Interface

3.1. USB

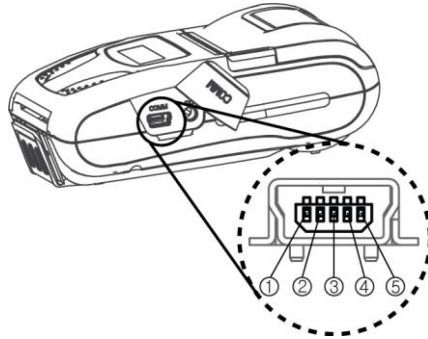

The WSP-R242 printer has a USB interface and is connected by means of a 5 pin mini USB socket. In the following table, the signals present on the Mini- USB socket are listed:

Pin No.	Name	Function
1	VCC	+5V
2	DM	DATA "-"
3	DP	DATA "+"
4	NC.	-
5	GND	Ground

NOTE :

- If you connect the printer interface cable is converted to USB mode.
- When data receiving, when it removes the communication cable, it loses a data.

3.2. Bluetooth

Category	Specification
Bluetooth Spec.	Bluetooth Ver3.0 / Class2 (10m)
Frequency band	2402~2480 MHz
Protocol	L2CAP, RFCOMM, SDP
Profile	GAP, SDAP, SPP

3.3. Magnetic Card Reading

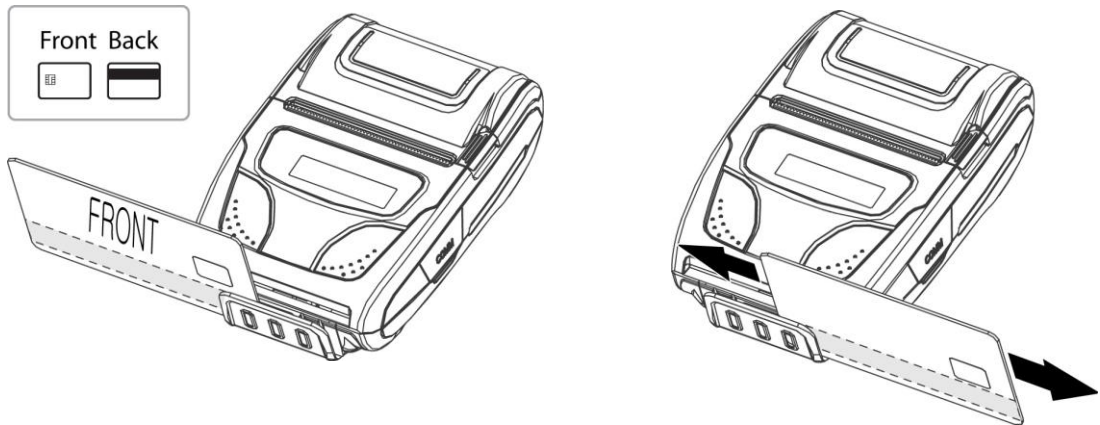

- ▶ Check the direction of the magnetic stripe card and reading.
- ▶ Cards can be read in both directions.
- ▶ If the reading is successful, the card buzzer once, beep three times if it fails.

4. Smart Card Reader Module

4.1. General Spec.

- ▶ Contact Smart Card Reader Module for ISO/IEC-7816
- ▶ Support Asynchronous Protocol T=0,T=1
- ▶ Smart Card Connection
 - Short Circuit Current Limitation
 - 6KV ESD Protection on whole Smart Card Interface
 - Connector : Friction Type with Smart Card presence detection
- ▶ 2 SAM (Security Application Module)
- ▶ EMV Level 1 Certified

4.2. Inserting the SAM card

To install SAM card, proceed as follows:

- Insert the SAM card in the direction of the arrow.

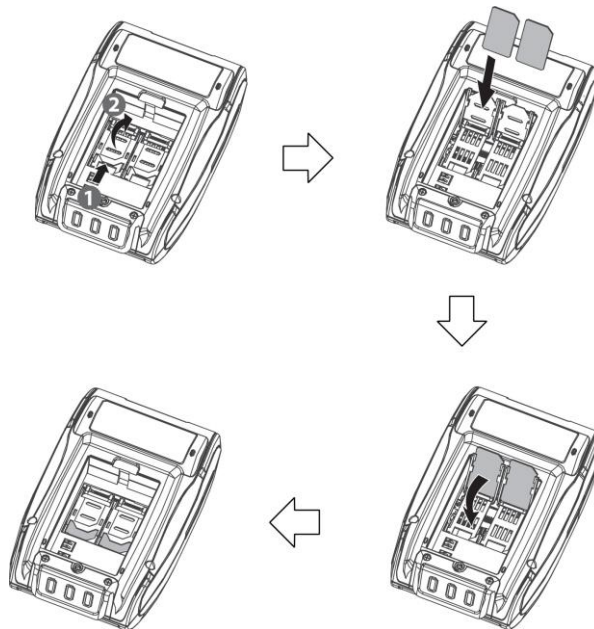

4.3. Inserting the IC card

- ▶ Check the contact IC chip and the card in the direction of the arrow insert.

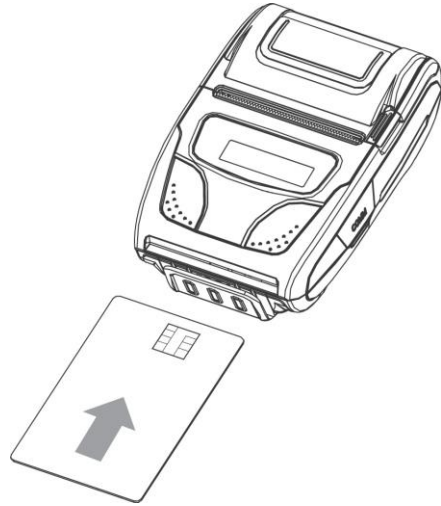

4.4. Communication Protocol Sequence

4.4.1. Regular Operation

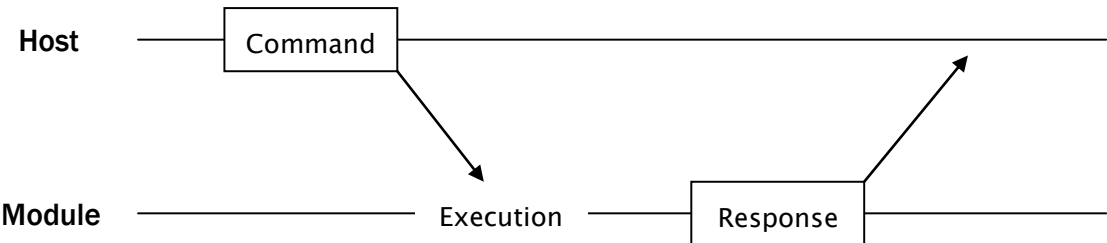

4.4.2. Irregular Operation (Communication Error)

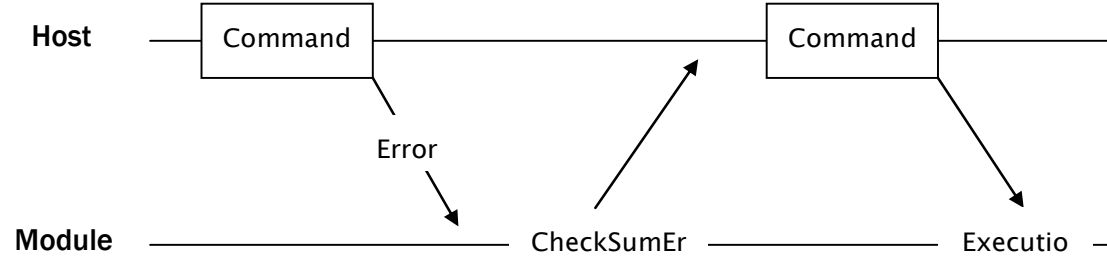
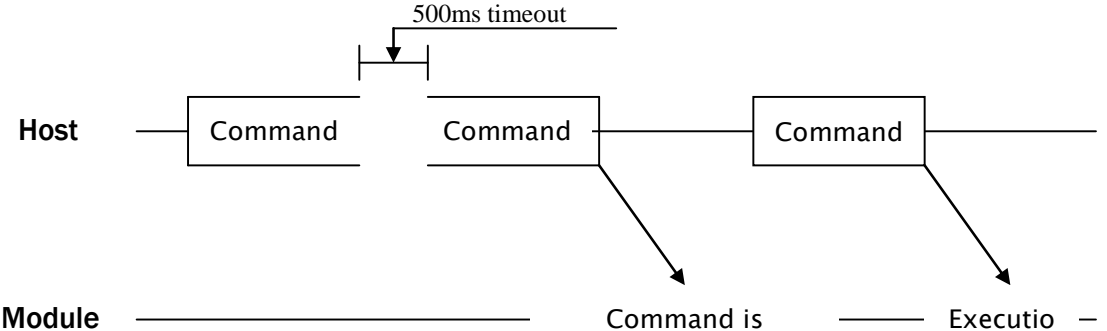

5. Using the printer

5.1. Control panel.



► BUTTON

- **FEED Button** : Use to feed paper continuously.
- **POWER Button** :
 - ① When of 5 or more seconds presses and power comes to on or off.
 - ② After pressing the POWER and the FEED button simultaneously, if the ERROR lamp 5 turn signals POWER button is converted with MODE functions.
- In keeping on pressing the **Feed and Power button** simultaneously until after the **LCD backlight** blinks 5 times, the printer comes out at the circumstance to change the printer mode. (Refer to **2.6. Set operation mode** for details about mode conversion)

► LCD

- LCD will display most of the printer status.
(details: current printer status, paper out, indicated remaining battery, communication connection etc.)

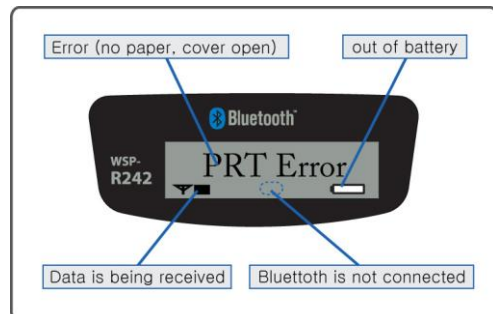
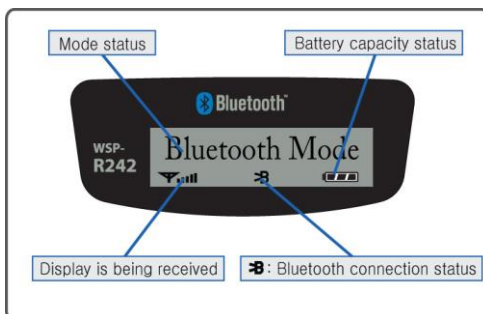

5.2. The self test

Self-Test prints out the current setting value of printer. The way of self-test is as follows.

1. Insert proper paper into the printer.
2. Power on while pressing feed button to start self-test.
3. Printer will print out the current status. (F/W version and set contents)
4. And then pattern of characters will be printed out.
5. Self-test will be finished automatically and turned to the standby status.

※ In case printer does not work properly, please contact Woosim customer service center.

5.3. Using the Belt clip

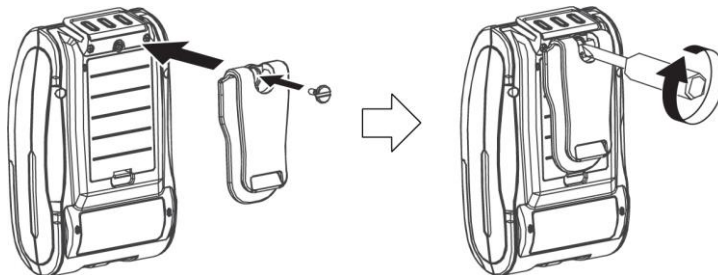

Following the instruction of the arrow, please put the belt clip in the hole and turn and fix the screw to the right by using a screw driver.

Afterward, you can use it like the picture below.

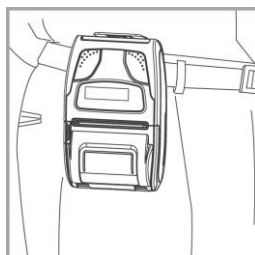

6. Consumable Parts.

6.1. Recommended paper.

Type	: Thermal Paper
Paper width	: 58mm
Paper thickness	: $60 \pm 5 \mu\text{m}$
Outer diameter	: $\text{Ø}40\text{mm}$ or less
Recording side	: Outside of roll



Cautions

1. Do not paste the paper to the core. And the roll paper which has Near end mark printing on its near end is recommended.
2. Chemicals or oil may change the color of paper, or printed Characters may fade.
3. Change of paper color starts from approx 70 °C.
Pay attention to heat, humidity and sun light.
4. Color of paper may be changed by being scratched by nail or hard metal, etc

6.2. Printing position.

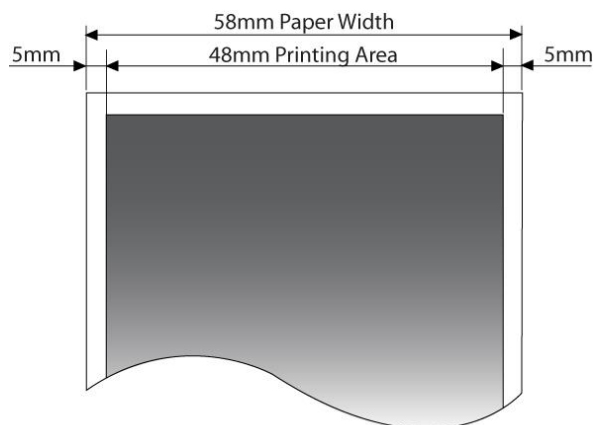

7. Revision History

Date	Version	Comments
Oct. 13. 2015	1.0	Initialize