

 Nakamichi®

SHOCKWAVE ELITE USER GUIDE



 DOLBY AUDIO™

 HDMI®
HIGH-DEFINITION MULTIMEDIA INTERFACE

7.2
CHANNEL



106
DECIBELS
AS LOUD AS
106dB



STOP
PLEASE DO NOT
RETURN THIS UNIT

Talk to a SHOCKWAVE PRO sound bar specialist
support@nakamichi-usa.com

Our one-stop support solution:
www.nakamichi-usa.com/faq

24HRS OR LESS
RESPONSE TIME
GUARANTEED

IMPORTANT SAFETY INSTRUCTIONS

Your Unit is designed and manufactured to operate within defined design limits, and misuse may result in electric shock or fire. To prevent your Unit from being damaged, the following rules should be observed for its installation, use, and maintenance. Please read the following safety instructions before operating your Unit. Keep these instructions in a safe place for future reference.

- Read these instructions.
- Keep these instructions.
- Heed all warnings.
- Follow all instructions.
- Do not use this apparatus near water.
- Clean only with a dry cloth.
- Do not block any ventilation openings. Install in accordance with the manufacturer's instructions.
- Do not install near any heat sources such as radiators, heat registers, stoves, or other apparatus (including amplifiers) that produce heat.
- Do not defeat the safety purpose of the polarized or grounding-type plug. A polarized plug has two blades with one wider than the other. A grounding type plug has two blades and a third grounding prong. The wide blade or the third prong are provided for your safety. If the provided plug does not fit into your outlet, consult an electrician for replacement of the obsolete outlet.
- Protect the power cord from being walked on or pinched, particularly at plugs, convenience receptacles, and the point where they exit from the apparatus.
- Only use attachments/accessories specified by the manufacturer.
- Use only with the cart, stand, tripod, bracket, or table specified by the manufacturer, or sold with the apparatus. When a cart is used, use caution when moving the cart/apparatus combination to avoid injury from tip-over.
- Unplug this apparatus during lightning storms or when unused for long periods of time.
- Refer all servicing to qualified service personnel. Servicing is required when the apparatus has been damaged in any way, such as when the power supply cord or plug is damaged, liquid has been spilled or objects have fallen into the apparatus, the apparatus has been exposed to rain or moisture, does not operate normally, or has been dropped.
- To reduce the risk of electric shock or component damage, switch off the power before connecting other components to your Unit.
- Unplug the power cord before cleaning your Unit. A damp cloth is sufficient for cleaning. Do not use a liquid or a spray cleaner on your Unit. Do not use abrasive cleaners.
- Always use the accessories recommended by the manufacturer to insure compatibility.
- When moving your Unit from an area of low temperature to an area of high temperature, condensation may form in the housing. Wait before turning on your Unit to avoid causing fire, electric shock, or component damage.
- Slots and openings in the back and bottom of the cabinet are provided for ventilation. To ensure reliable operation of your Unit and to protect it from overheating, be sure these openings are not blocked or covered. Do not place your Unit in a bookcase or cabinet unless proper ventilation is provided.
- Never push any object into the slots and openings on your Unit enclosure. Do not place any objects on the top of your Unit. Doing so could short circuit parts causing a fire or electric shock. Never spill liquids on your Unit.
- When connected to a power outlet, power is always flowing into your Unit. To totally disconnect power, unplug the power cord.
- Do not overload power strips and extension cords. Overloading can result in fire or electric shock.



- The wall socket should be located near your Unit and be easily accessible.
- Keep your Unit away from moisture. Do not expose your Unit to rain or moisture. If water penetrates into your Unit, unplug the power cord and contact your dealer. Continuous use in this case may result in fire or electric shock.
- Do not use your Unit if any abnormality occurs. If any smoke or odor becomes apparent, unplug the power cord and contact your dealer immediately. Do not try to repair your unit yourself.
- Avoid using dropped or damaged appliances. If your Unit is dropped and the housing is damaged, the internal components may function abnormally. Unplug the power cord immediately and contact your dealer for repair.
- Continued use of your Unit may cause fire or electric shock.
- Do not install your Unit in an area with heavy dust or high humidity. Operating your Unit in environments with heavy dust or high humidity may cause fire or electric shock.
- Ensure that the power cord and any other cables are unplugged before moving your Unit.
- When unplugging your Unit, hold the power plug, not the cord. Pulling on the power cord may damage the wires inside the cord and cause fire or electric shock. When your Unit will not be used for an extended period of time, unplug the power cord.
- To reduce risk of electric shock, do not touch the connector with wet hands.
- Insert the remote control batteries in accordance with instructions. Incorrect polarity may cause the battery to leak which can damage the remote control or injure the operator.
- The marking label of the subwoofer was located on the external bottom enclosure of the product.
- The equipment shall be used at maximum 35 degree Celsius ambient temperature.
- See the important note and rating located on the back of the unit.
- WARNING - This equipment is not waterproof. To prevent a fire or shock hazard, do not place any container filled with liquid near the equipment (such as a vase or flower pot) or expose it to dripping, splashing, rain, or moisture.
- To prevent injury, this apparatus must be securely attached to the floor/wall in accordance with the installation instructions.
- CAUTION - Danger of explosion or fire if batteries are mistreated. Replace only with the same or specified type.
- Do not leave the batteries exposed to direct sunlight for a long period of time with doors and windows closed. Do not disassemble the batteries or dispose of it in fire.
- Where the MAINS plug or appliance coupler is used as the disconnect device, the disconnect device shall remain readily operable.

WARNING: To reduce the risk of fire or electric shock, do not expose this apparatus to rain or moisture.



This lightning flash with arrowhead symbol within an equilateral triangle is intended to alert the user to the presence of not isolated dangerous voltage within the product that may be sufficient magnitude to constitute a risk of shock to persons.



The exclamation point within an equilateral triangle is intended to alert the user to the presence of important operating and servicing instructions in the literature accompanying the appliance



Warning: This equipment is a Class II or double insulated electrical appliances. It has been designed in such way that it does not require a safety connection to electrical earth.

TABLE OF CONTENTS

Package Contents	4
Control and Connections	5
Setting up the SHOCKWAFE Elite System	8
Setting your TV.....	13
Connecting your TV	14
Advance Setup: Non-HDMI	16
Advance Setup: HDMI.....	17
One Device Setup	18
Two Device Setup.....	19
Three Device Setup.....	20
Four Device Setup.....	21
Audio Settings for Streaming Devices	22
Using the Remote.....	23
Accessing SOURCES on your Remote.....	24
Accessing SETUP on your Remote.....	25
Accessing MENU on your Remote	26
Accessing INFO on your Remote	27
Accessing EQs on your Remote	28
Saving Audio Setting to system Memory.....	29
Accessing ROOM SIZE on your Remote	30
Using Bluetooth Mode	31
Re-linking the Subwoofer with the Soundbar	32
Wall Mounting the Soundbar	33
Wall Mounting the Satellite Speakers.....	35
Firmware Upgrade.....	36
Help & Troubleshooting	37
Warranty Information & Customer Support	38
Glossary	39
Specification	41
Legal & Compliance	42

PACKAGE CONTENTS



SHOCKWAVE ELITE
Sound bar

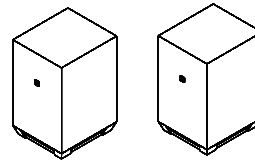

Dual Wireless
Subwoofer

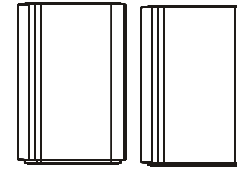

2 x Satellite
Speakers



Remote Control
with Batteries



2 x Subwoofer Power cables
1 x Soundbar Power cables
(Length: 5 ft.)



2 x Satellite Speaker Audio Cables
(Length 16.4 ft. each)



HDMI Cable
(Length: 5 ft.)

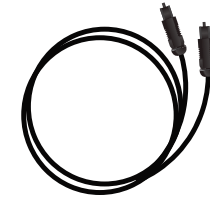

Digital Optical cable
(Length: 5 ft.)



3.5mm Audio Cable
(Length: 4 ft.)

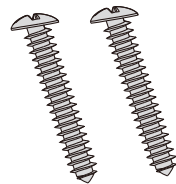

12 x Wall Screws

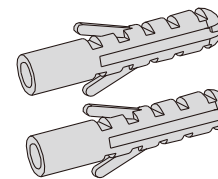

12 x Screws Brackets

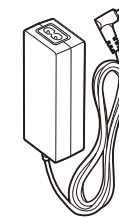

Power Adapter
(Length: 5 feet)

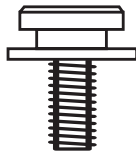

2 x Mounting Screws
(Sound bar)

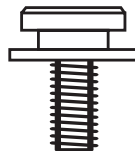

4 x Mounting Screws
(Satellite Speakers)



6 x Sound Bar
and Satellite
Wall Mount
Brackets



Mounting Guide

CONTROLS & CONNECTIONS

Back of Sound Bar

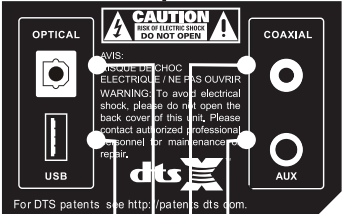
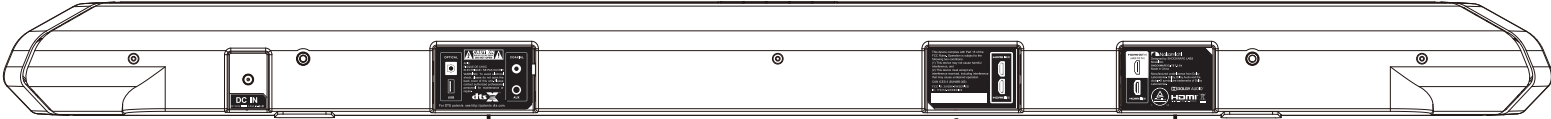

USB
USB IN (WMA & MP3 music playback and Firmware update)

OPTICAL
Digital Optical Audio in

AUX
Analog Audio In (Stereo 3.5mm)

COAXIAL
Digital Coaxial Audio in

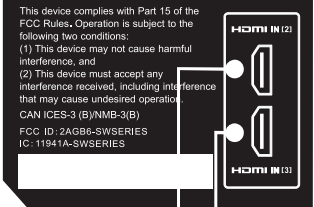

HDMI IN [2]
(compatible with HDCP 2.2, 4K HDR pass thru)

HDMI IN [3]
(compatible with HDCP 2.2, 4K HDR pass thru)



HDMI OUT [1]
(ARC TO TV)

HDMI IN [4]
(compatible with HDCP 2.2, 4K HDR pass thru)

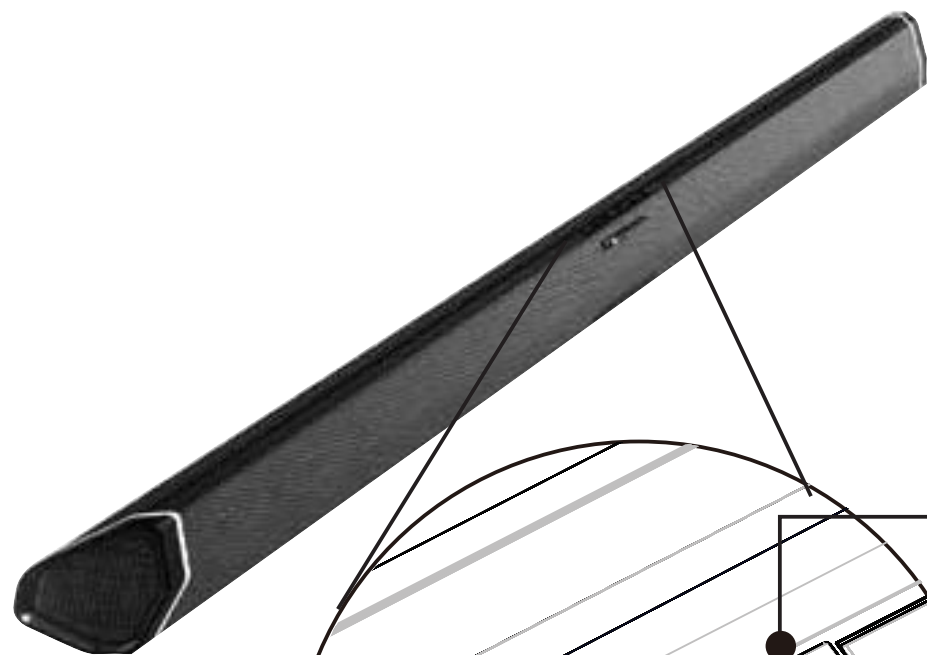

Top of Sound Bar

Volume

Press to increase or decrease the volume.

Demo

Press to play NAKAMICHI audio test tone.

Input

Press to change the audio source.

Power

Press to turn Sound Bar On or Standby.

Back of LEFT Subwoofer

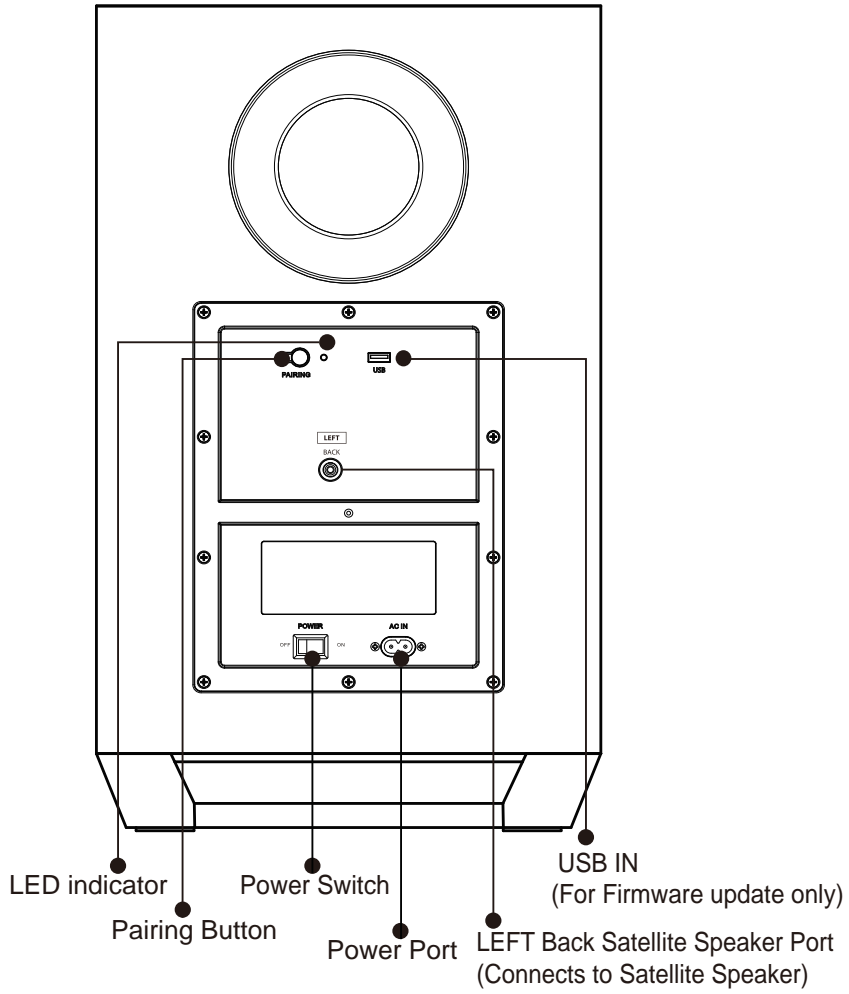

Back of RIGHT Subwoofer

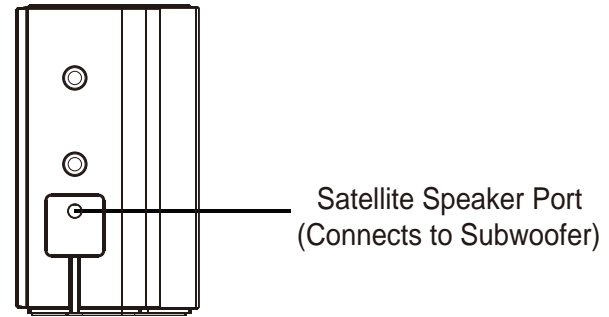
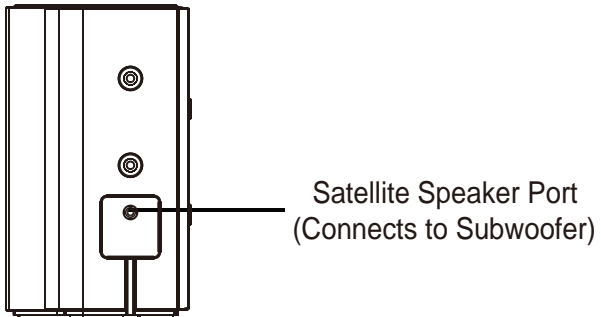
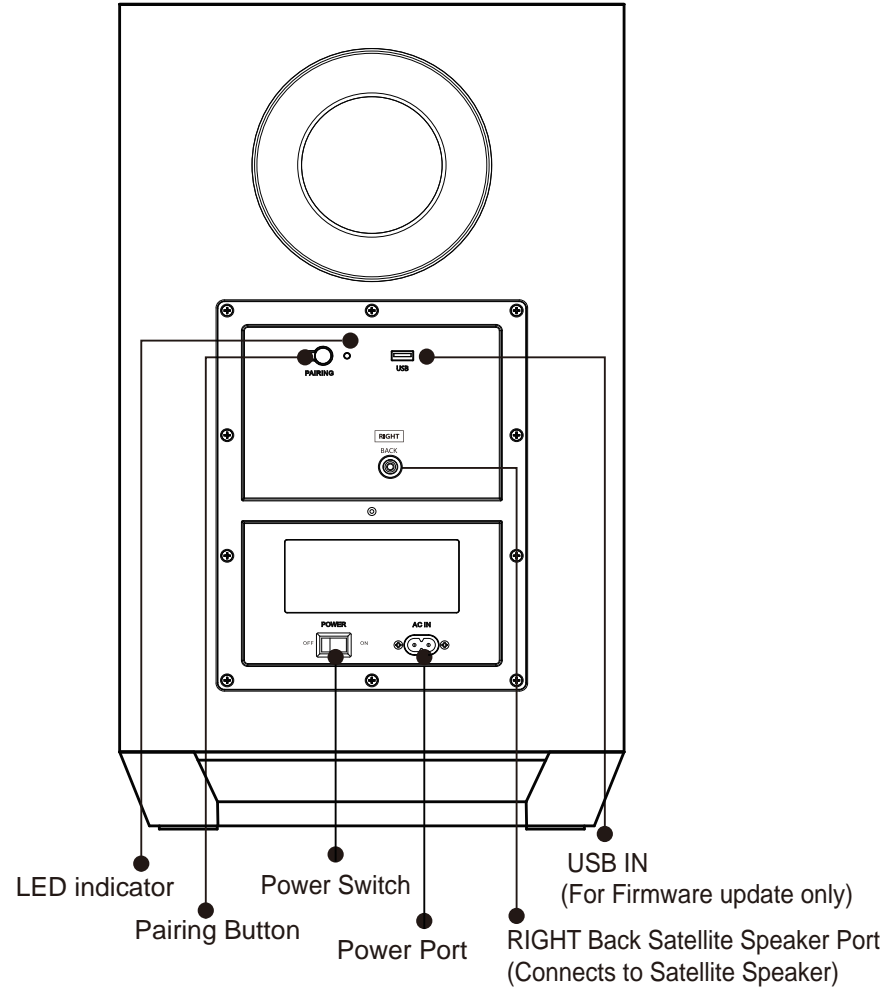

SETTING UP THE SHOCKWAVE ELITE SYSTEM

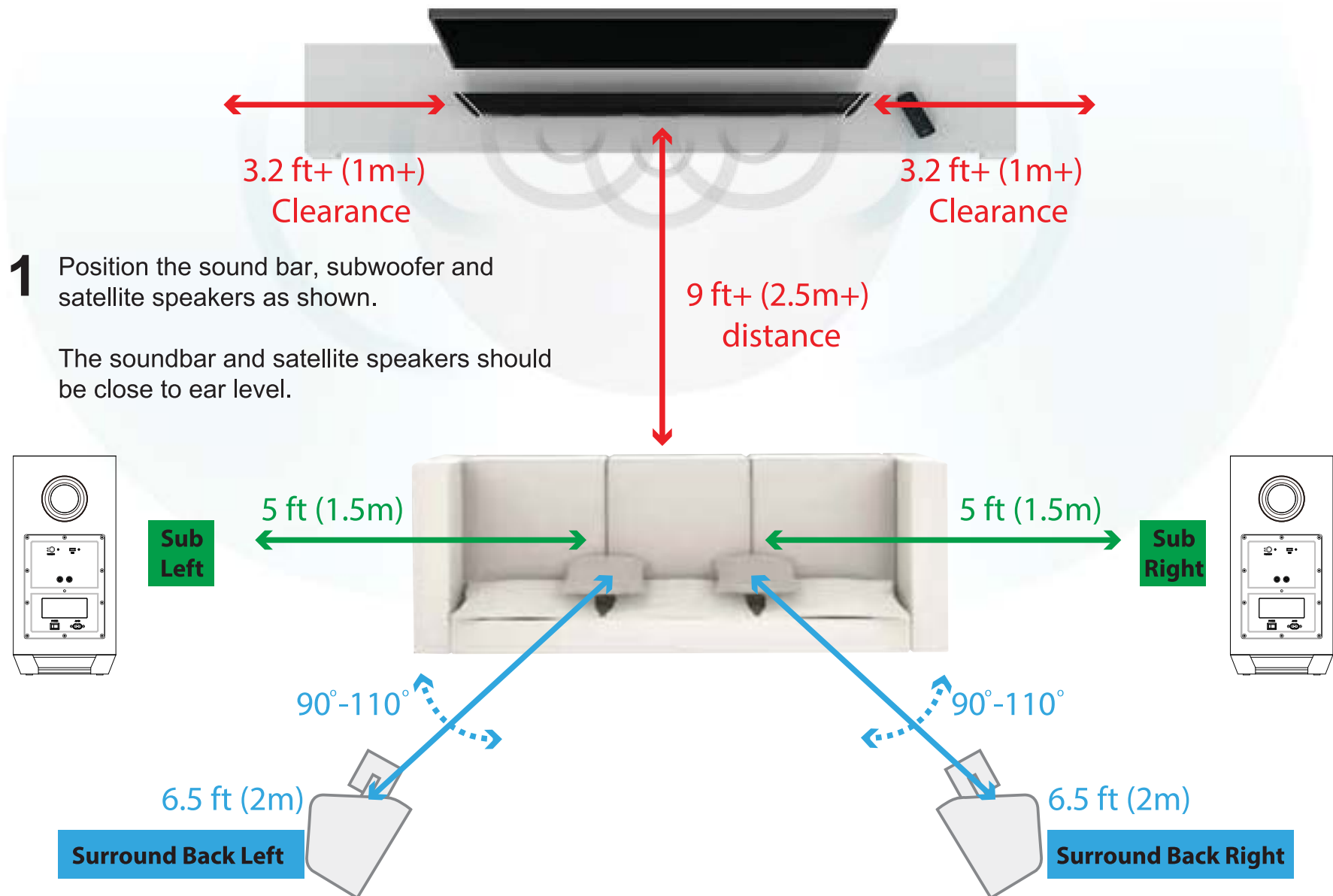

Note: Speaker stands not included.

Back of Sound Bar

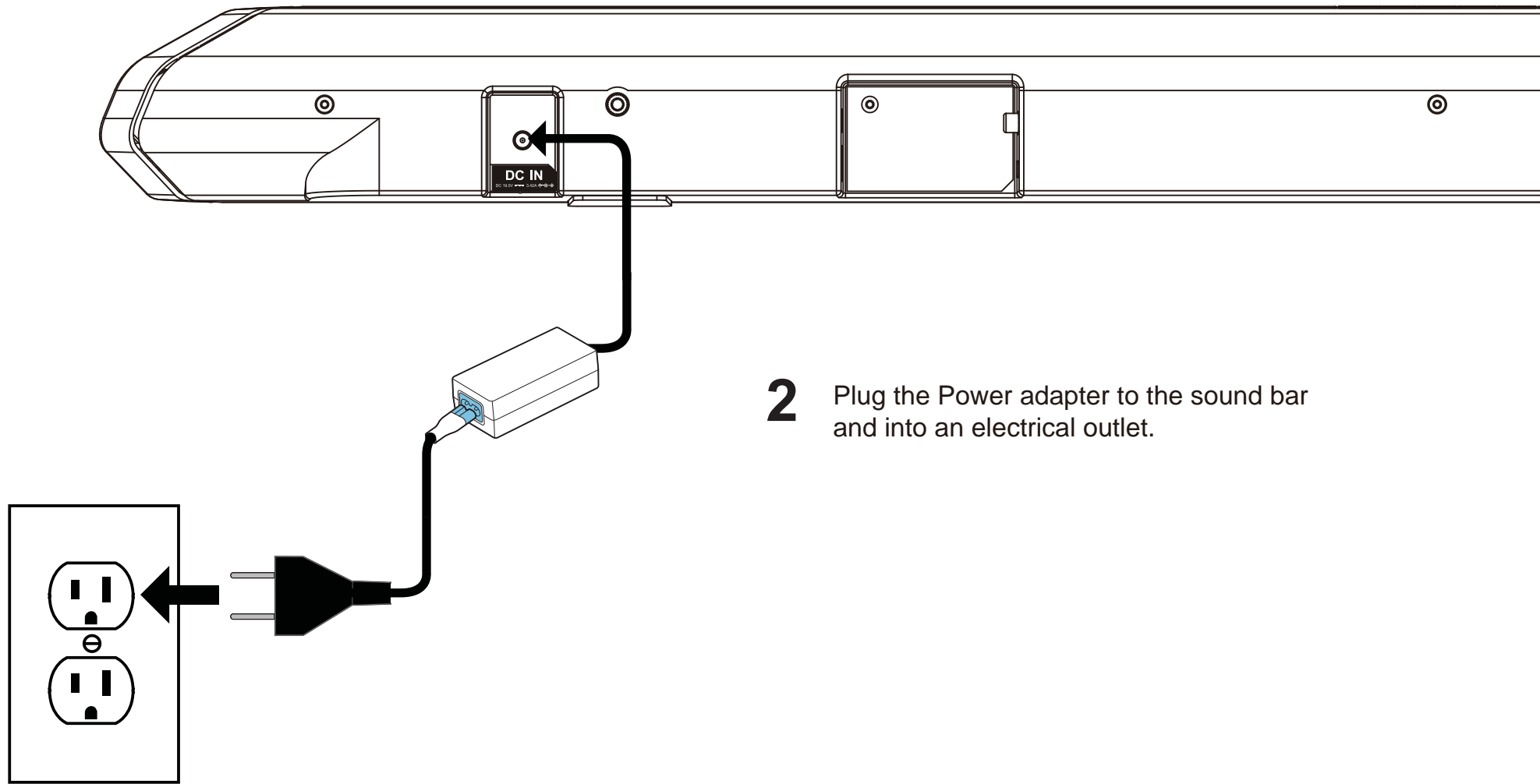

- 2** Plug the Power adapter to the sound bar and into an electrical outlet.

- 3** Connect the LEFT Back satellite speakers to the LEFT subwoofer using the included satellite speaker audio cables.
Connect the RIGHT Back satellite speakers to the RIGHT subwoofer using the included satellite speaker audio cables.

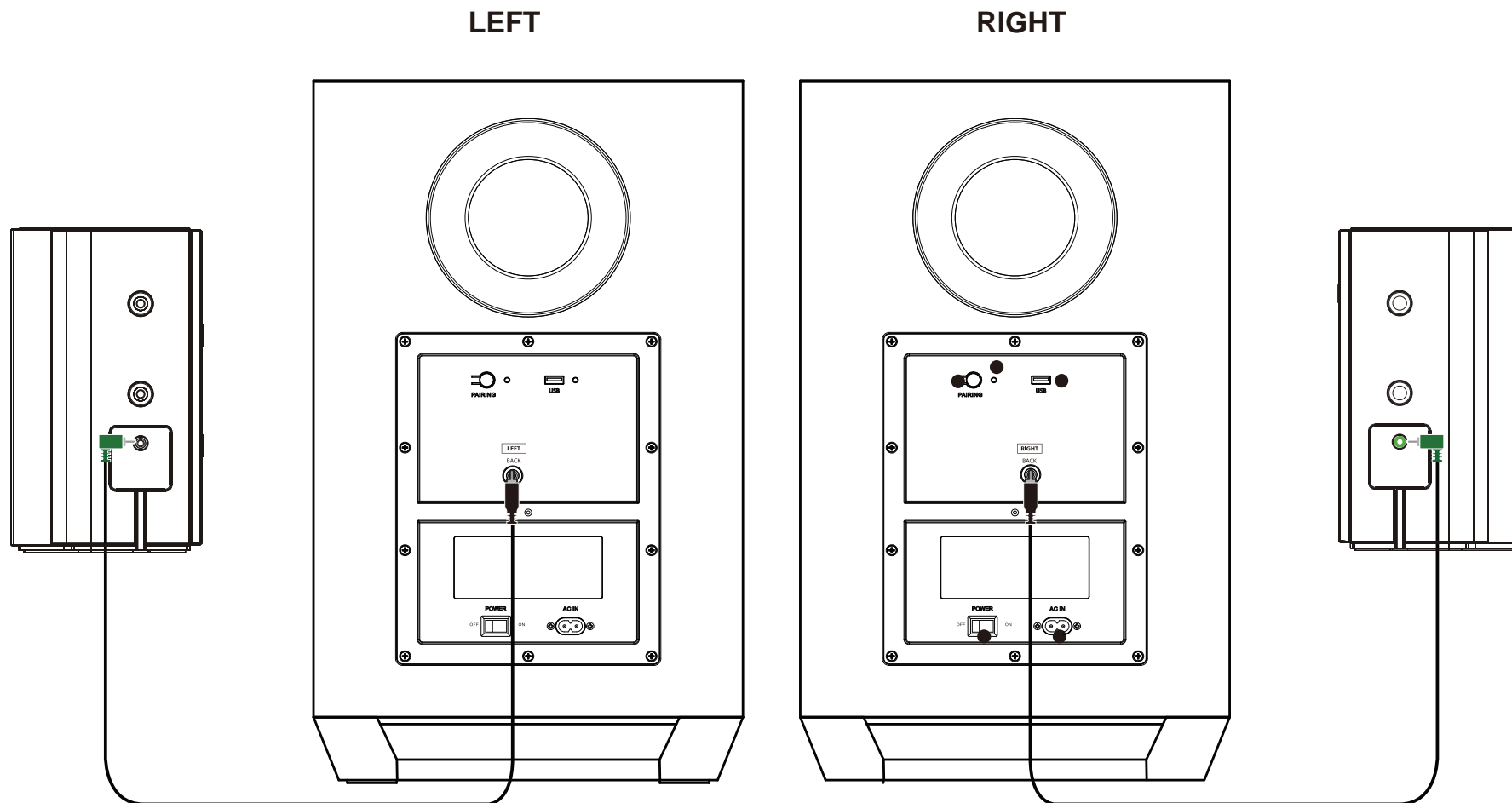

LEFT & RIGHT Subwoofer

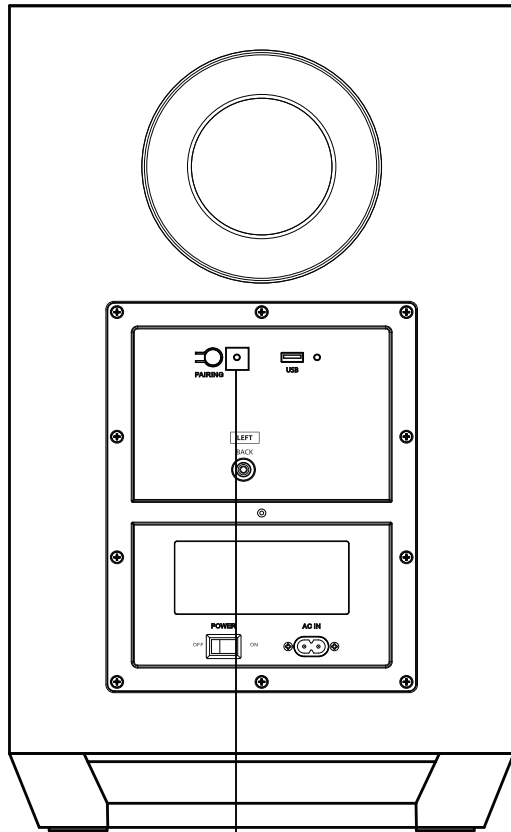

Blue LED Indicator

Blinking Blue light: subwoofer ready to pair
Blue light stays on: subwoofer successfully paired

4

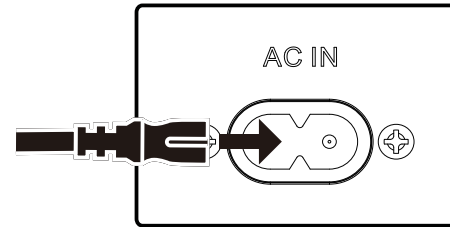

Connect a power cable to the subwoofer.

5

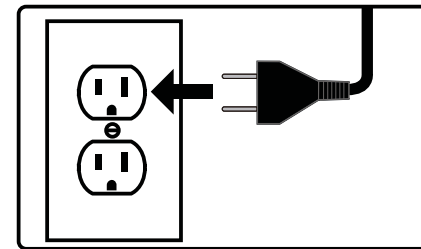

Plug the power cable into a power outlet.

6

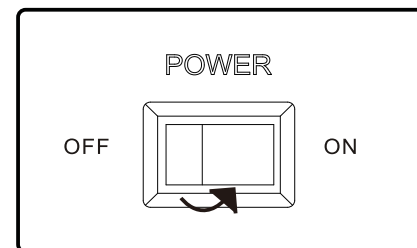

Flip the power switch into the **ON** position.

7

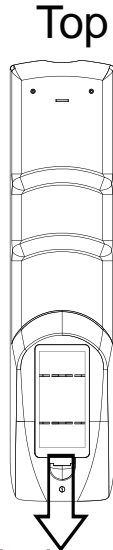

Remove the battery cover by pulling it out from the remote.

8

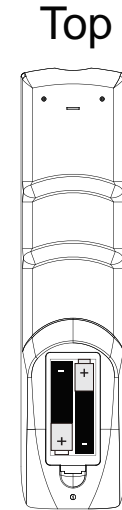

Insert the batteries included in the accessories box and gently push the battery cover back into place.

9

Turn your Soundbar on by pressing the Power button. Use respective input keys to select an audio input source to be played.

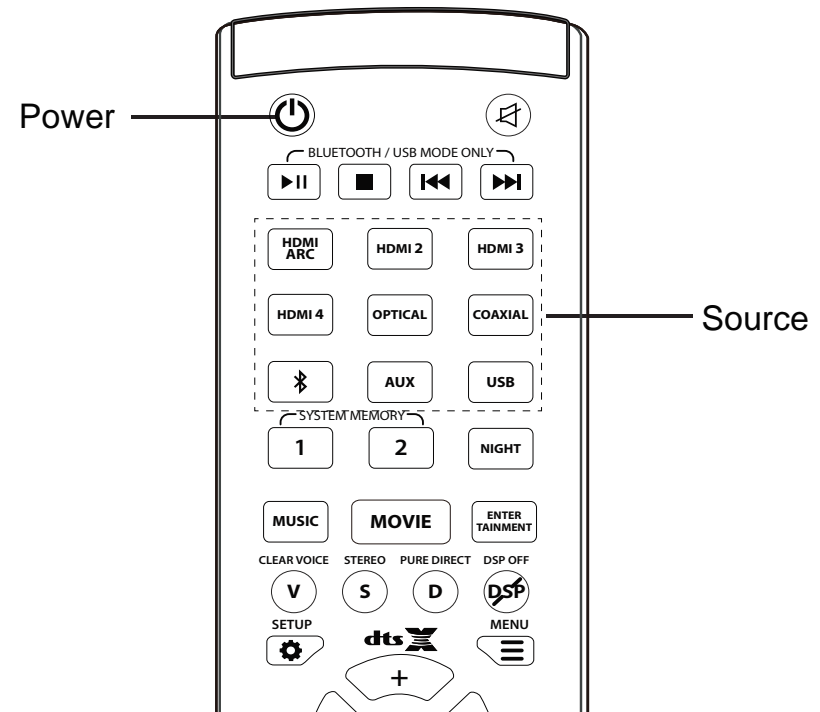

SETTING YOUR TV

What is HDMI Audio Return Channel (ARC)?

Using HDMI ARC, your TV can send audio to the sound bar using a HDMI cable.

You will need to connect your sound bar to your TV's HDMI ARC port using a HDMI cable that is ARC compatible.

Audio settings for TV*

Setting the audio output:

- A) Go to Settings > Sound
- B) Select Speaker Setting
- C) Set as Audio Out

Setting the audio format:

- A) Go to Settings > Sound > Additional setting
- B) Select Audio Format
- C) Set as Dolby Digital / DTS / Bit stream

What is CEC?

CEC is a HDMI protocol that is only available when:

1. Your TV is CEC enabled. (Check your TV manual for more information)
2. The sound bar and TV is connected via a HDMI cable through the ARC ports.

By doing so, you are able to control the sound bar's volume and power functions with the TV remote.

Enabling CEC †

From the SYSTEM menu, enable CEC and ARC (SAC)† functions.

From the CEC menu, select Device Discovery to register the sound bar with the TV.

* Steps may differ by TV manufacturer. See your TV's user manual for more information.

† HDMI-CEC TV Trade names: Samsung (Anynet++), Sharp (Aquos Link), Sony (Bravia Sync), LG (SimpLink), Panasonic (HDAVI Control, EZ-Sync, Viera Link), Philips (EasyLink), Vizio (CEC), Hitachi (HDMI-CEC)

Naming may differ by TV manufacturer. See your TV's user manual for more information.

CONNECTING THE TV

1

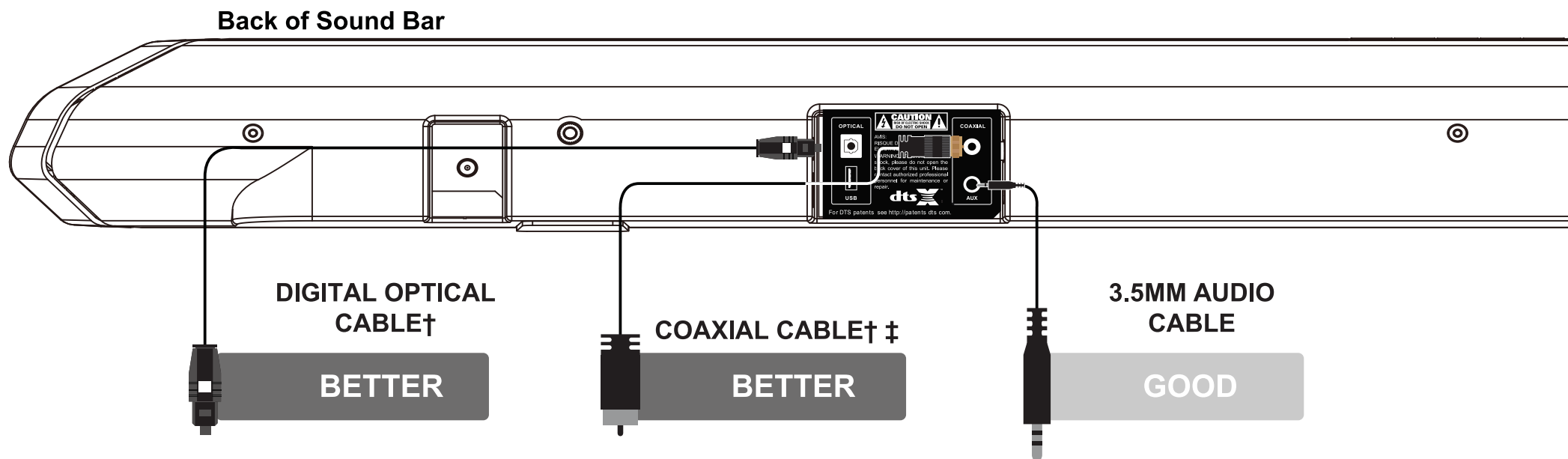

**CHOOSE ONE CABLE
AND CONNECT
IT TO YOUR TV**

- GOOD
- OR
- BETTER
- OR
- BEST

(See next page)

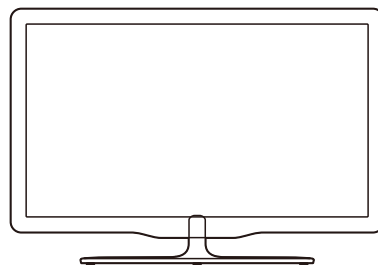

Be sure the TV port is an audio output, not an audio input.

* Not all TVs have the audio outputs shown above. To connect the Sound Bar directly to your other devices (Blu-Ray player, game system, etc.) see your device's user manual.

* Cable appearance may differ from the ones supplied.

† audio: (A) Try setting the TV output to PCM or (B) Connect directly to your Blu-ray/other source, some TVs do not pass through digital audio.

‡ Cable not included.

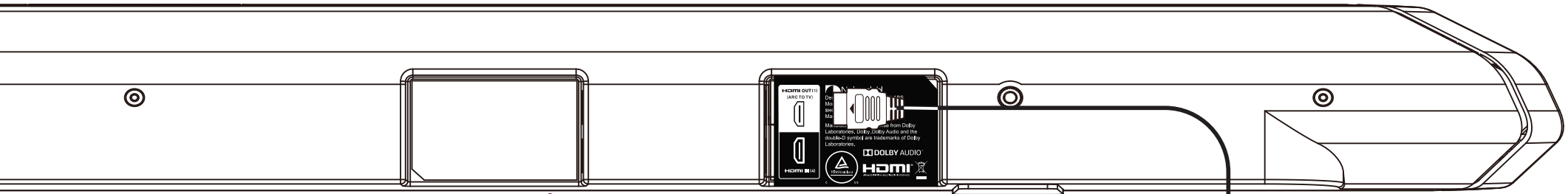

1. Connect one end of the HDMI cable to the HDMI (ARC) port at the back of your TV.
2. Connect the other end to the TV HDMI [1] (ARC) port on your Nakamichi sound bar.

(HDMI cables send Video (Out) and receive Audio from the TV)

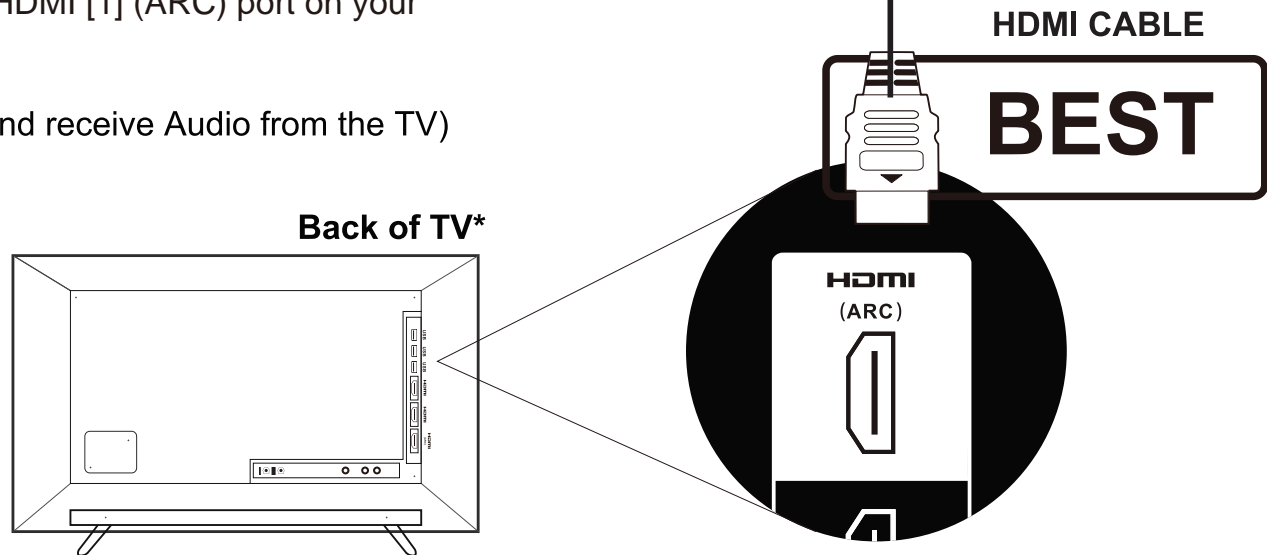

* HDMI ARC port location may differ by TV manufacturer. See your TV's user manual for more information.

SETUP - NON HDMI

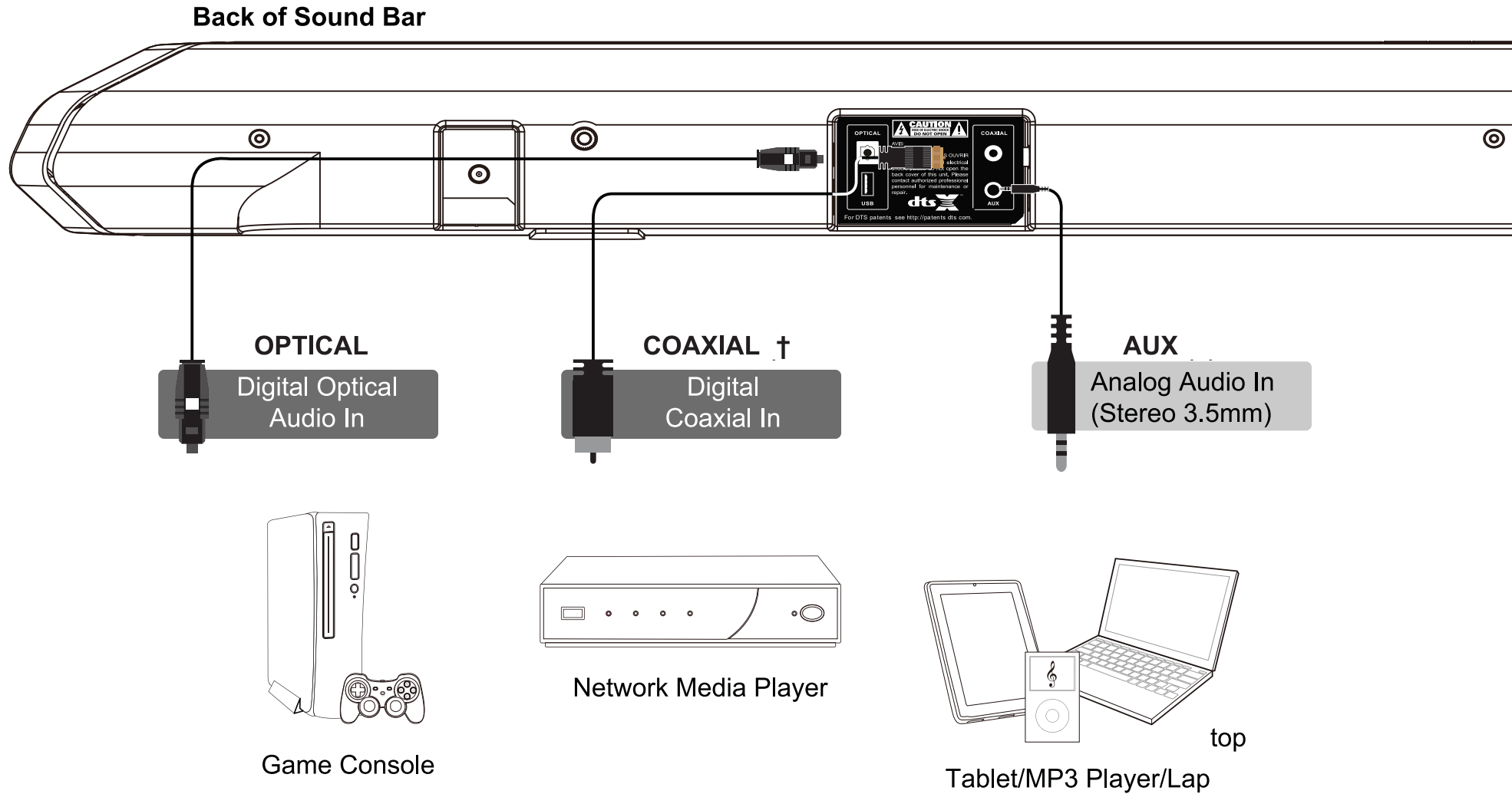

† Cable not included

ADVANCED SETUP - HDMI

HDMI cables transmit both audio and video. To view video from these devices, turn the Soundbar on, then set the **Soundbar input** to HDMI IN [2], HDMI IN [3] or HDMI IN [4]. Set your **TV input** to the HDMI ARC port to which the Soundbar is connected.

Back of Sound Bar

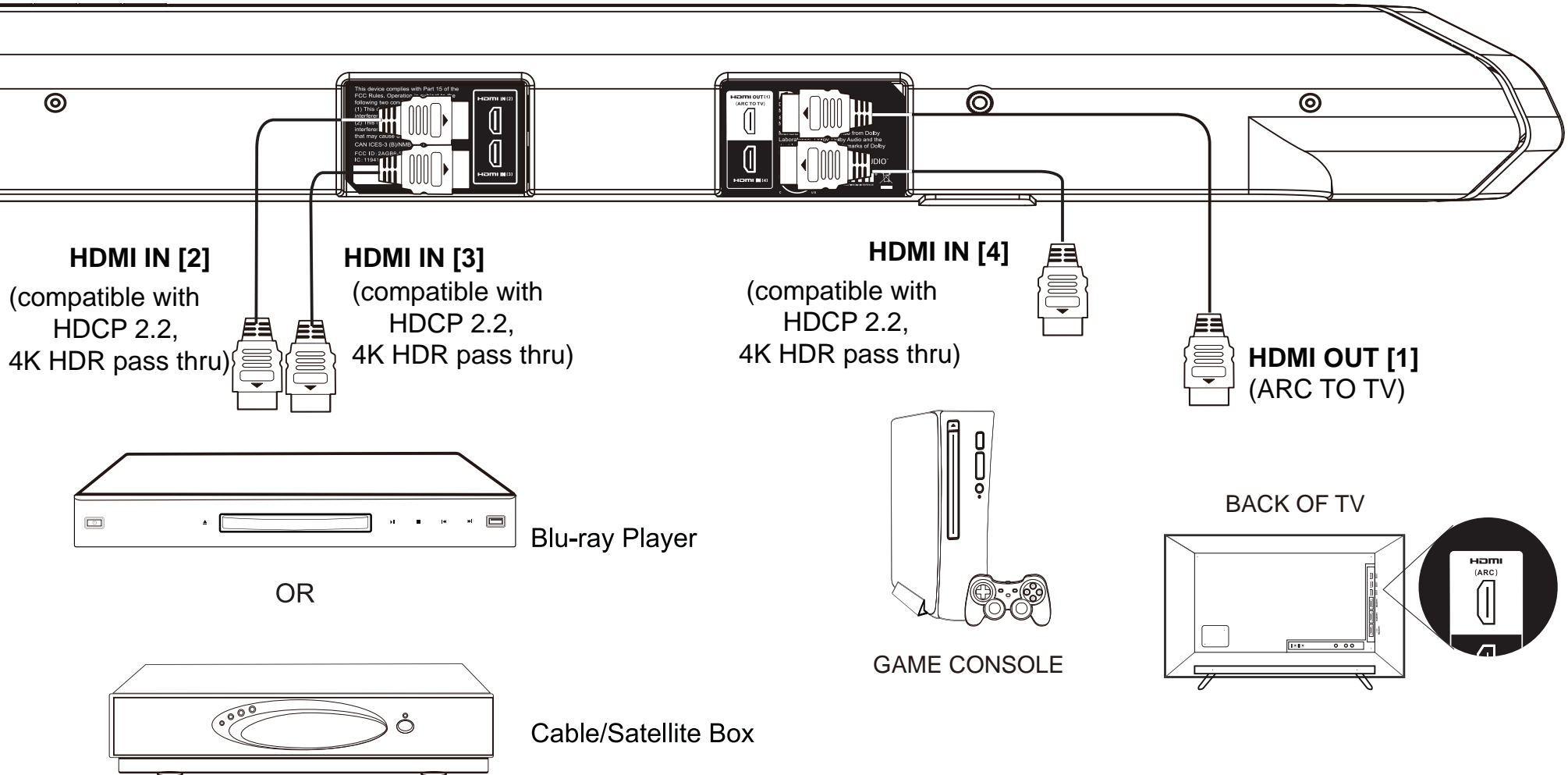

* Cables appearance may differ from the ones supplied.

One Device Setup:

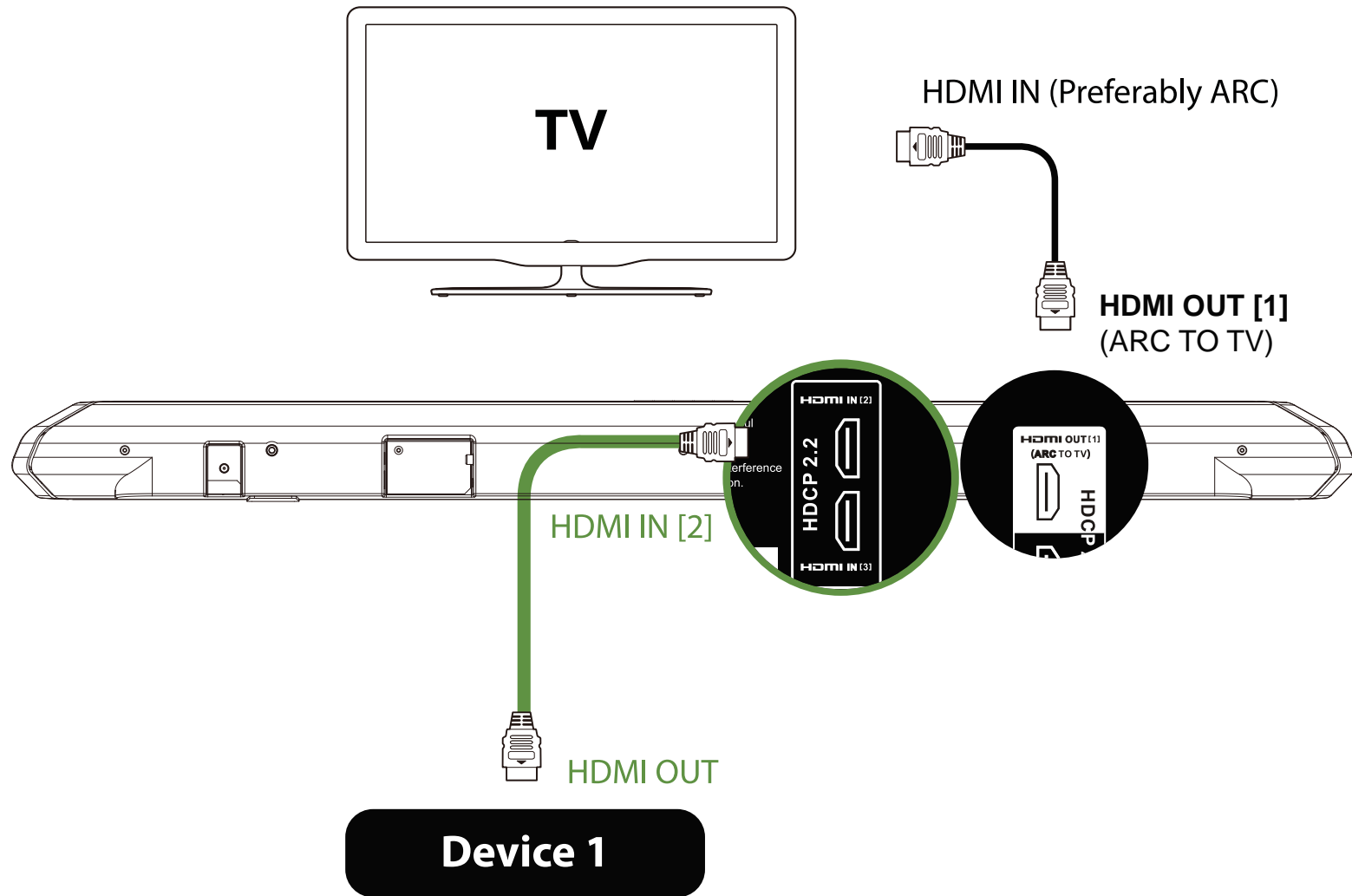

Two Devices Setup:

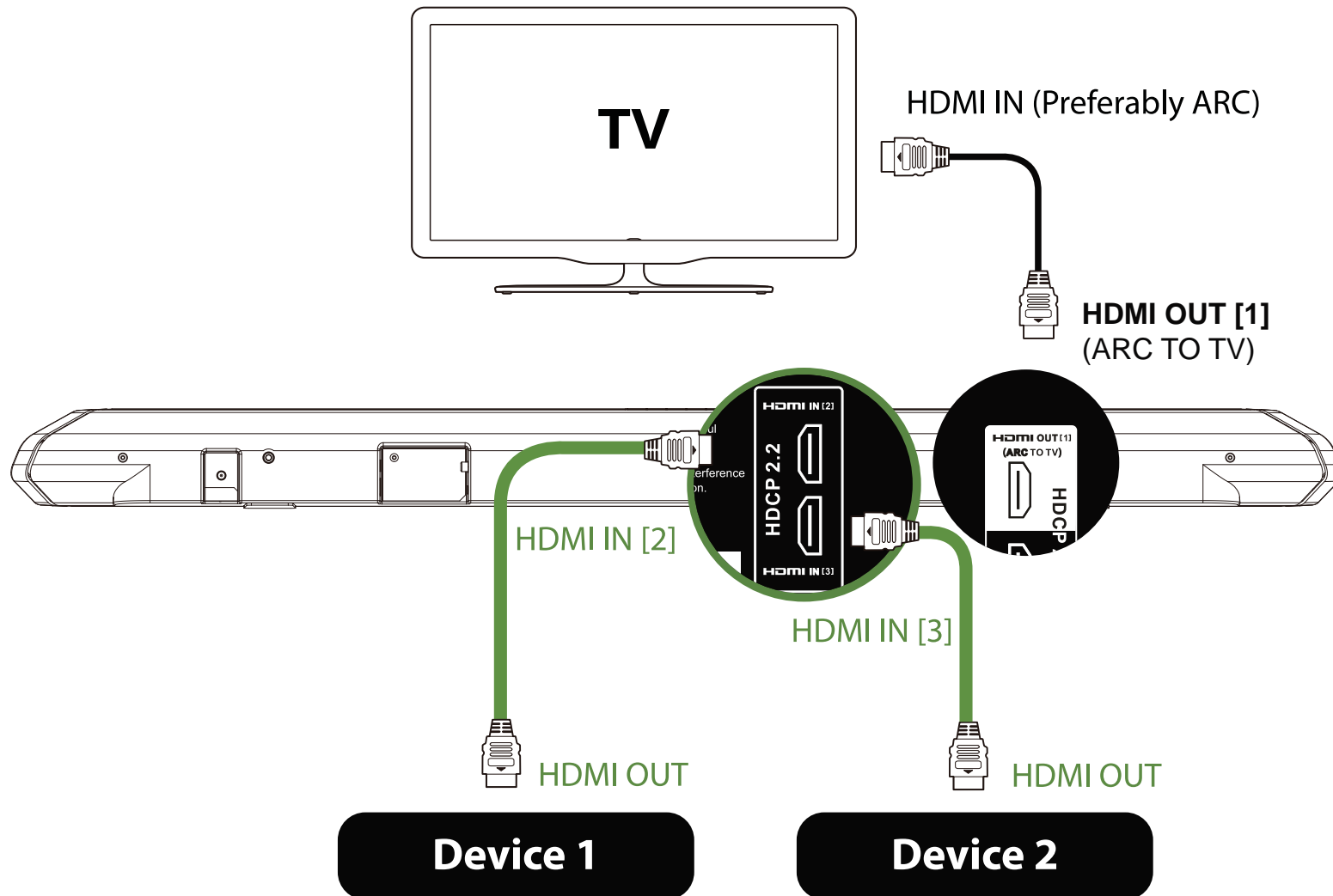

If the device is not equipped with a HDMI port, use an Optical or Coaxial output.

Three Devices Setup:

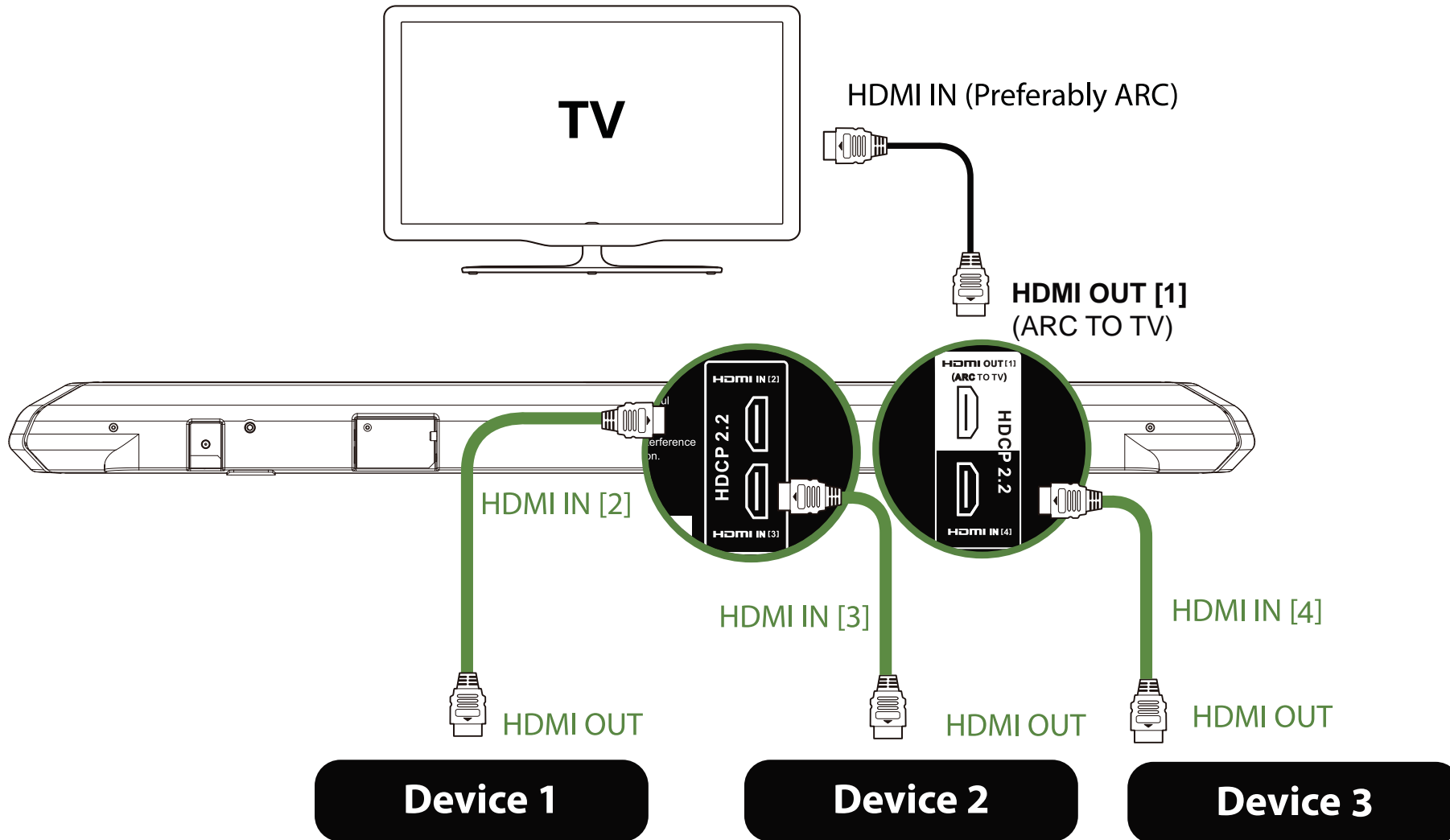

Four Devices Setup:

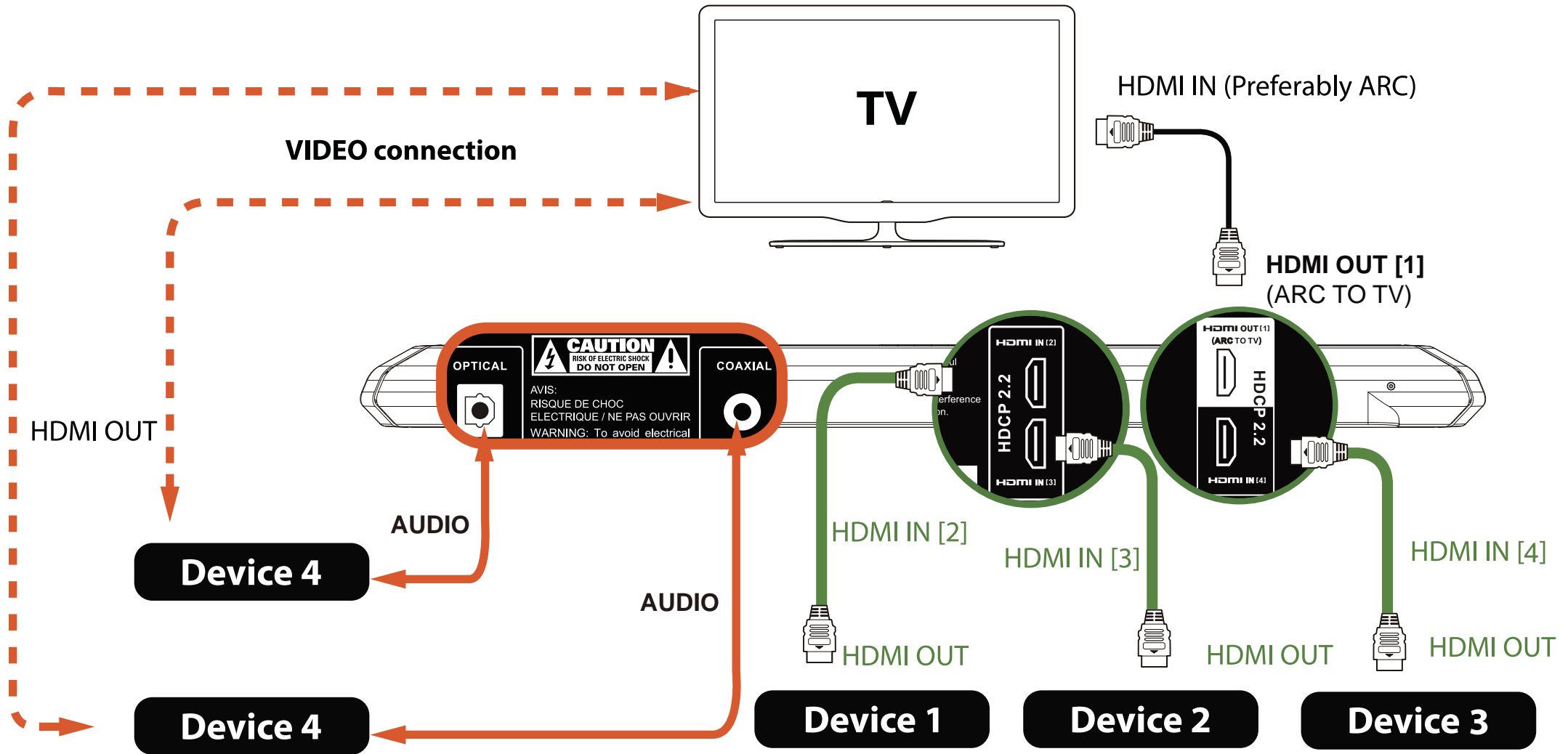

If the device is not equipped with a HDMI port, use an Optical or Coaxial output.

AUDIO SETTINGS FOR STREAMING DEVICES

Blu-Ray™/DVD™ Players

- A) Go to Settings
- B) Select Audio
- C) Set as Dolby Digital / DTS / Bit stream

Amazon™ Fire TV

- A) Go to Settings
- B) Select Display & Sounds
- C) Select Audio
- D) Set Dolby Digital Plus

Apple™ TV 3

- A) Go to Settings
- B) Select Audio & Video
- C) Set as Audio Output to 16 Bit

Apple™ TV 4

- A) Go to Settings
- B) Select Audio & Video
- C) Select Surround Sound
- D) Set as Dolby Digital 5.1

Roku™ 4

(Optical Connection Recommended)

- A) Go to Settings
- B) Select Audio
- C) Select Audio Mode
- D) Set to DD, DTS

PlayStation® 4

Setting the audio output:

- A) Go to Settings
- B) Select Sound Settings
- C) Select Audio Output Settings
- D) Set Connector Type to HDMI Audio or Optical audio

Setting the secondary audio format:

- A) Play the movie (this step is important)
- B) Press the Options button on the controller
- C) Go to Settings > Audio Format
- D) Set to Dolby Digital 5.1 / DTS 5.1 / Bitstream

XBox® One

- A) Go to Settings
- B) Select Display & Sound
- C) Set Audio Output
- D) Set Digital Audio to HDMI Audio or Optical Audio
- E) Set Audio Options to Bit stream Out

*Be sure to connect via the **HDMI OUT** port when the HDMI cable is used on the Xbox One.*

XBox® 360

- A) Go to Settings
- B) Select System
- C) Select Console Settings
- D) Select Audio
- E) Select Digital Output
- F) Set to Dolby Digital 5.1

Xfinity®

- A) Go to Setting
- B) Select Audio Codec
- C) Select HDMI or Optical
- D) Set Audio Range to Normal
- E) Set Audio Output to Fixed

We are constantly updating this list.
If you do not find your streaming device here,

Please visit :
www.nakamichi-usa.com/audio-settings

Contact us:
support@nakamichi-usa.com

USING THE REMOTE

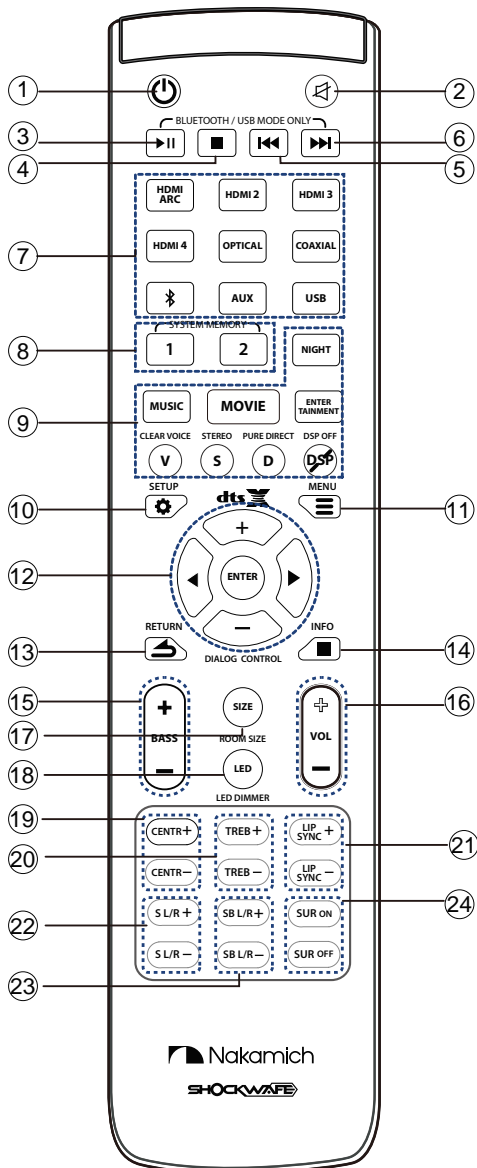

- ① **Power** Press to turn on/off the Soundbar.
- ② **Mute** Press to mute/unmute the Soundbar.
- ③ **Play/ Pause** Press to play/pause track in Bluetooth or USB mode.
- ④ **Stop** Press to stop track in USB mode.
- ⑤ **Previous** Press to return to the previous track in Bluetooth or USB mode.
- ⑥ **Next** Press to skip to the next track in Bluetooth or USB mode.
- ⑦ **Input Source** Press to select an audio input source.
- ⑧ **System Memory** Press to save volume and other audio settings.
- ⑨ **EQs** Press to cycle through different EQs.
- ⑩ **SETUP** Press to display the setup settings: DTS:X & DOLBY DRC, ECO mode and Factory reset. To use Setup function, please switch to HDMI ARC input.
- ⑪ **MENU** Press to display menu settings: Firmware upgrade and Wireless subwoofer pairing. To use Menu function, please switch to USB input.
- ⑫ **DTS:X** **Dialog Control.** Press to adjust the DTS:X audio content's Dialog (Human voices) level.
Left, Right Arrow and Enter. Press to change the setting in Setup and Menu function.
- ⑬ **Return** Press to return to the previous selection in Setup and Menu function.
- ⑭ **Info** Press to display the information display on the front LED Display.
- ⑮ **Bass +/-** Press to adjust the dual subwoofers' level.
- ⑯ **Vol +/-** Press to adjust the volume of the Soundbar.
- ⑰ **Room Size** Press to select a pre-define optimized room size (Small, Medium and Large) loudness.
- ⑱ **LED Dimmer** Press to adjust the front LED Display's brightness.
- ⑲ **Center +/-** Press to adjust the center level.
- ⑳ **Treble +/-** Press to adjust the high tones (treble) level.
- ㉑ **SURR L & R +/-** Press to adjust the surround left & right speakers' volume.
- ㉒ **SURR Back L & R +/-** Press to adjust the surround back left & right speakers' volume.
- ㉓ **SURR On/Off** Press to enable/disable surround sound. When enabled (On), all inputs will produce 7.2 surround sound. When disable (off), the satellite speakers will be disabled.
- ㉔ **Lip Sync +/-** Press to adjust the deviations in timing between audio and video playback. Works for input: HDMI 1 to 4, Optical and Coaxial.

ACCESSING SOURCE ON YOUR REMOTE

Press respective buttons to select an audio input source.

Each input source (function) will be displayed on the Soundbar's front LED display.

Input source (function):

Button	5 LED DIGITS on Sound Bar
HDMI ARC	ARC
HDMI 2	HDMI2
HDMI 3	HDMI3
HDMI 4	HDMI4
OPTICAL	OPT
COAXIAL	COAX
BLUETOOTH	BT
AUX	AUX
USB	USB

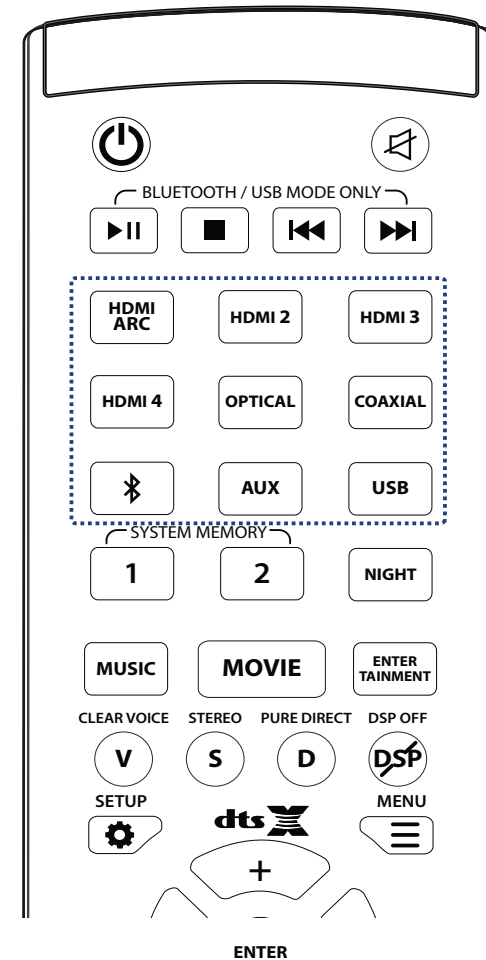

ACCESSING SETUP ON YOUR REMOTE

To use SETUP function, please **switch to HDMI ARC** input.

Setting the SETUP selection:

1. Press the **SETUP (⚙️)** button.

The selection changes as follows each time the SETUP (⚙️) button is pressed

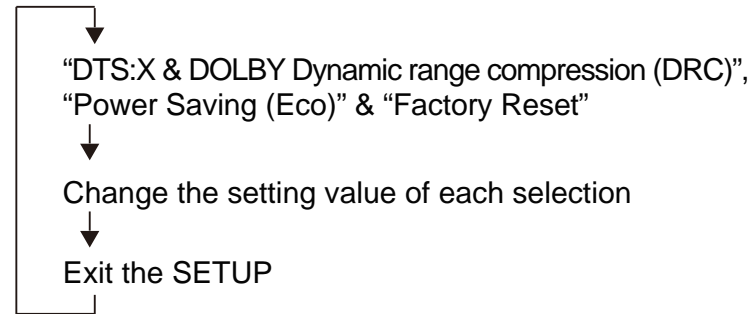

2. Press the **SETUP (⚙️)** button to access to different setup selection:

DRC > ECO > RESET, and press **ENTER**.

Repeat these steps to display the desired setup.

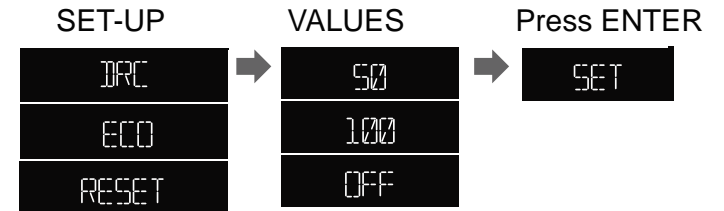

Press the **RETURN** button to return to the previous selection

3. Press the arrow button to change the setting value of each setup. Press **ENTER** to confirm.

4. Press the **SETUP (⚙️)** button again to exit the setup menu.

SET-UP Selection List:

SET-UP	SELECTION (Press ENTER)	VALUES	After 5 seconds
DTS:X & DOLBY Dynamic Range Compression (DRC)	DRC (Default OFF)	50%	Completed, LED display will go back to current input source.
		100%	
		OFF	
POWER SAVING (30 mins power off)	ECO (Default ECO ON)	OFF	Completed, LED display will go back to current input source.
		ON	
Factory Reset	RESET	YES	Completed, System Restarts
		ON	

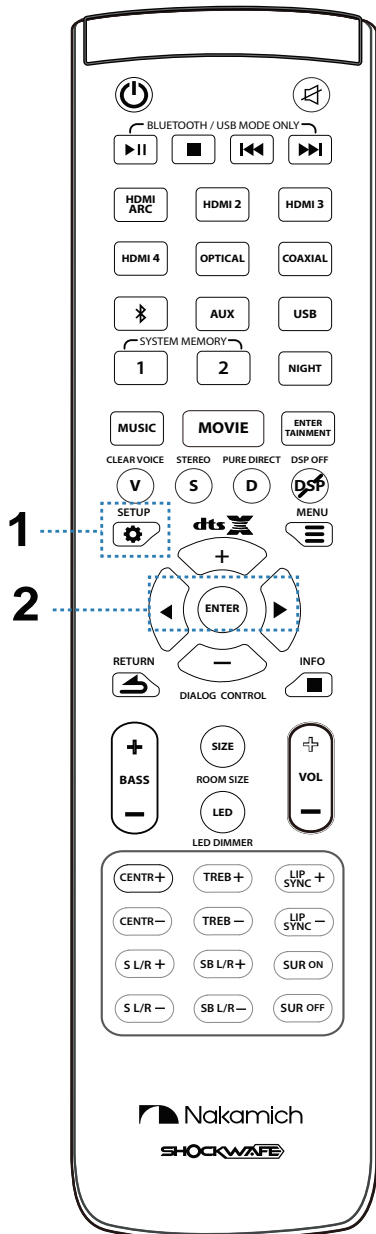

ACCESSING MENU ON YOUR REMOTE

To use MENU function, please **switch to USB** input.

Setting the MENU selection::

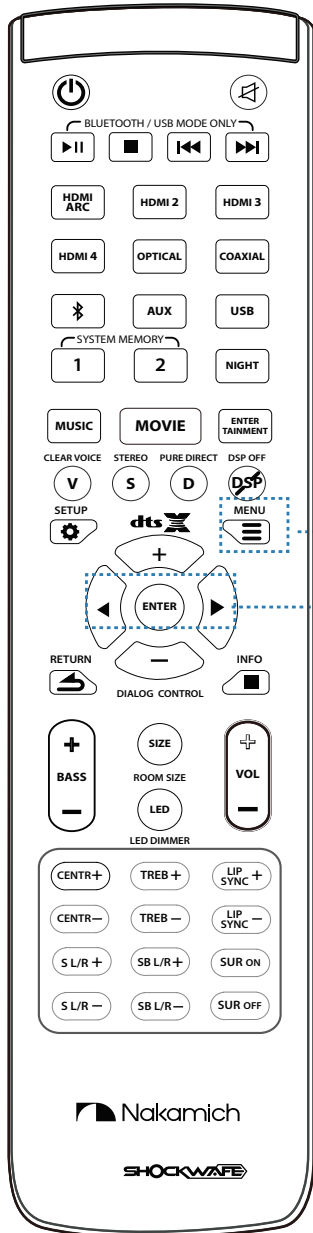

1. Press the MENU (≡) button to select



Firmware Upgrade (USB) or Wireless Subwoofer Pairing and press ENTER.

2. Soundbar performing task.

FW UPGRADE



Press the RETURN (↵) button to return to the previous selection

3. Press the MENU (≡) button to exit the MENU selection

SET-UP Selection List:

MENU	SELECTION	FUNCTIONS
FIRMWARE UPGRADE (USB)	FW UPGRADE	UPGRADING
		DONE
		FAIL
WIRELESS SUBWOOFER PAIRING	SUB PAIR	PAIRING
		DONE
		FAIL

ACCESSING INFO ON YOUR REMOTE

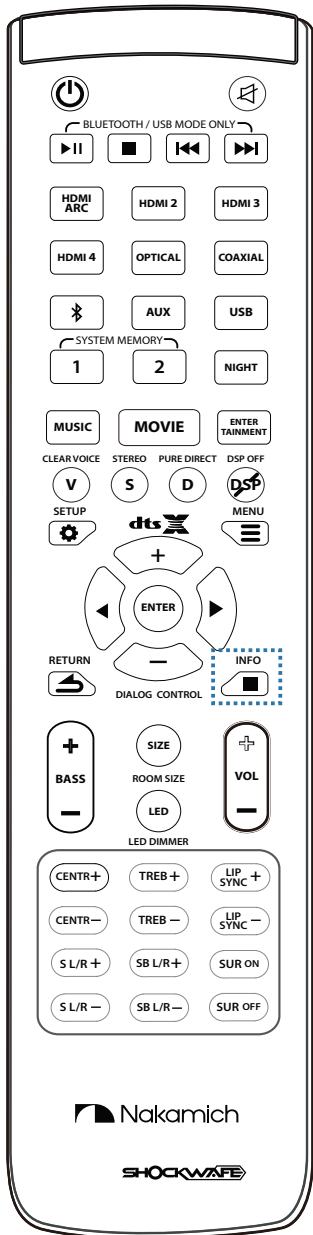

Switching information displayed on the front panel LED display.

Information regarding the Firmware version, Decoder format, EQs mode, Volume, Bass, Center, Treble, Surround and Surround back is displayed.

1. Press the INFO button.

Display changes as follows each time the INFO button is pressed.
The information varies according to the input source.

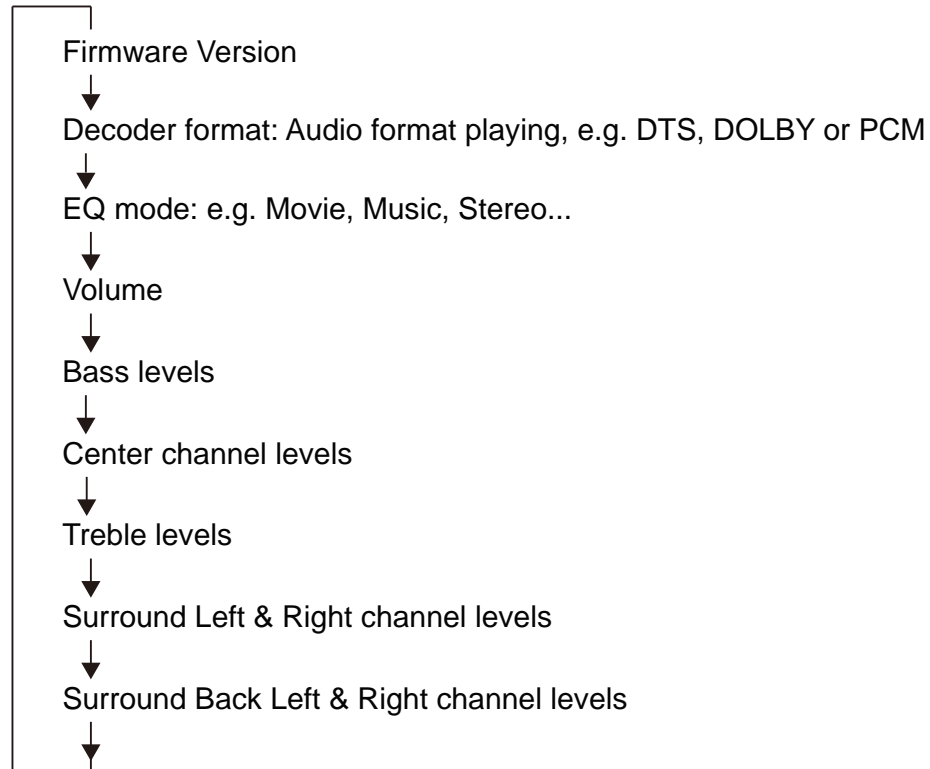

ACCESSING EQS ON YOUR REMOTE

Press the EQS buttons on your remote to select the desired EQs settings for your preferences. Each EQs settings will be displayed on the Soundbar's LED Display. MOVIE EQ is the default EQ setting. Every change in EQ, the system will remember the last setting.

NIGHT	BASS LOW	Reduces the Bass volume to level 01 for night time listening.
	ON	Enables the Subwoofers.
MUSIC	MUSIC	Reproduces the acoustic environment and lets you feel as if your seated in front of the singer's stage.
MOVIE	MOVIE	Reproduces the thrilling environment of action films and lets you feel the dynamic and excitement of action scenes.
ENTERTAINMENT	SPORTS	Reproduces the energetic environment of live sports broadcasting, converging a commentator's voice on the center and broadening the overall atmosphere of the stadium.
	NEWS	Reproduces excitement of live talk shows, it enhances the ambience of gaiety while keeping the conversation at a comfortable volume
	GAME	Reproduces sound field effects for adventure games to represent the depth and spatial feeling of the field.
CLEAR VOICE	CLEAR VOICE	Human voices, such as lines in movies and TV shows are played back very clearly.
STEREO	STEREO	2-channel stereo playback using the right front and left front channels is enabled. When multi-channel audio signals are inputted, they are down-mixed to 2 channels.
PURE DIRECT	PURE DIRECT	Disable DTS Neural:X upmixing. Direct decoder format playback in normal 2.0/ 5.1 /7.1 channel audio.
	NATIVE	Disable DTS Neural:X upmixing. Direct decoder format to native 2.0/ 5.1/ 7.1 channel audio.
DSP OFF	DSP OFF	Audio playback without using any pre-defined Nakamichi EQ settings.

LED Display of EQS Settings:

BASS 01	B LOW
ON	B ON
MUSIC	MUSIC
MOVIE	MOVIE
SPORTS	SPORTS
NEWS	NEWS
GAME	GAME
CLEAR VOICE	CLEAR VOICE
STEREO	STEREO
PURE DIRECT	PURE DIRECT
NATIVE	NATIVE
DSP OFF	DSP OFF

SAVING AUDIO SETTING TO SYSTEM MEMORY

Two sets of audio settings can be saved on the Soundbar's memory, enabling quick loading of settings optimized for user preference.

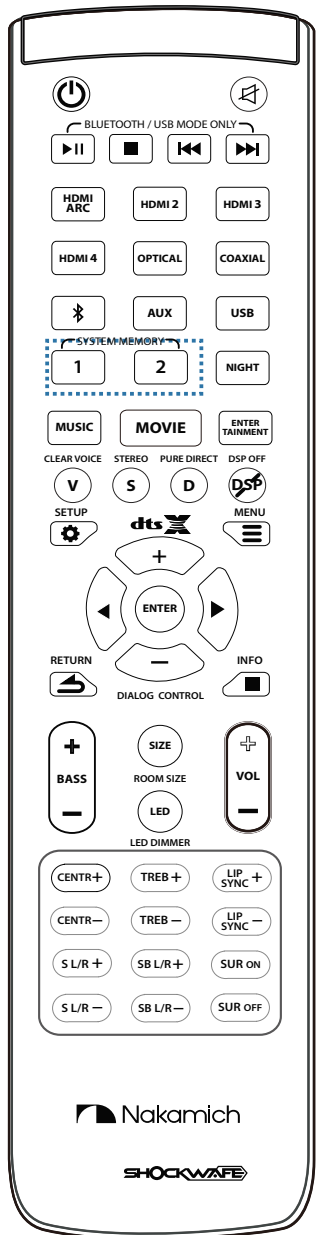

LED Display on Sound bar:

Function	Button	5 LED DIGITS on Sound Bar
DSP & VOL SYSTEM MEMORY	Customized Memory 1 Long press to SAVE1 Once saved, show M1SET	SAVE1
		M1SET
	Customized Memory 2 Long press to SAVE2 Once saved, show M2SET	SAVE2
		M2SET

Saving settings to system memory:

1. Hold down the SYSTEM MEMORY 1 or 2 button until “SAVE1” or “SAVE2”, corresponding to the button pressed, is displayed on LED.
 2. When the SYSTEM MEMORY 1 or 2 settings are saved, “M1SET” or “M2SET” is displayed.
- If system settings are already stored in the selected memory 1 or 2, the system overwrites the old settings.

Loading settings

1. Press the SYSTEM MEMORY 1 or 2 button once and the corresponding settings will be loaded. If the SYSTEM MEMORY 1 button is pressed, “M1” will be displayed.

The following audio settings can be saved to system memory:

- a) EQ mode
- b) Volume
- c) Bass
- d) Treble
- e) Center
- f) Surround L&R
- g) Surround Back L&R

ACCESSING ROOM SIZE ON YOUR REMOTE

Three presets of volume settings for Small, Medium and Large rooms is saved to this unit's memory, enabling quick loading of settings **optimized** for different room sizes

Room Size	Small	Medium (Average)	Large
Square feet	199	326	484
Room dimension: Length x Width (feet)	14 x 14	18 x 18	22 x 22

LARGE ROOM

22ft x 22ft
(484ft. sq.)

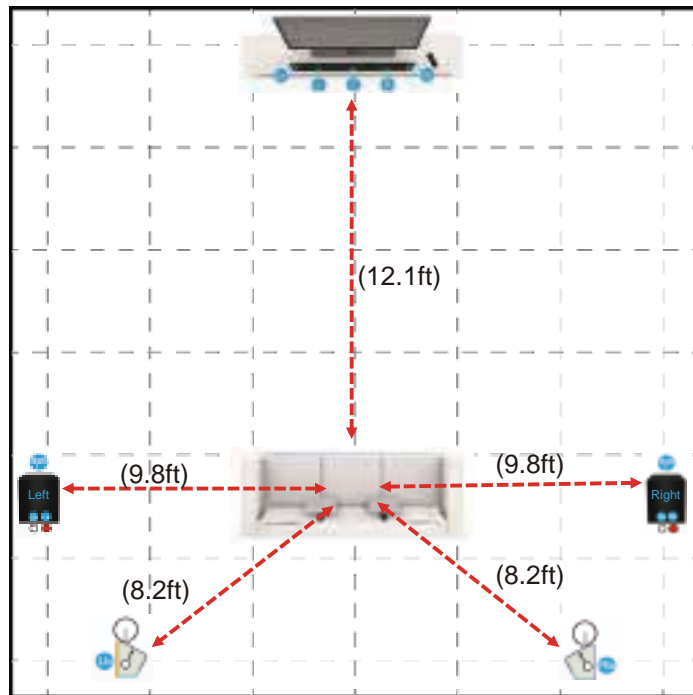

MEDIUM ROOM

18ft x 18ft
(326ft. sq.)

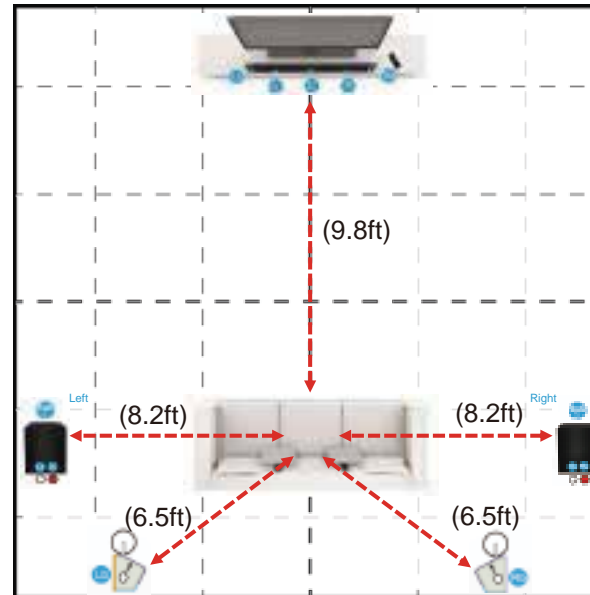

SMALL ROOM

14ft x 14ft
(199ft. sq.)

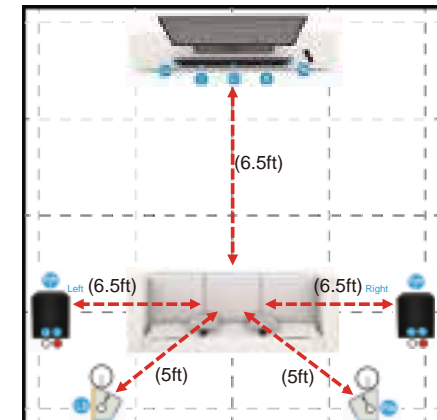

USING BLUETOOTH MODE

Your Sound Bar supports music streaming from smartphones, tablets, and computers with Bluetooth capability. Device compatibility will vary, see your device's documentation for more information.

Once you have paired your source device to the Sound Bar, as long as you stay within range of the Sound Bar, your device should remain paired.

If the input is changed, the Bluetooth device will disconnect. If the source is changed back to Bluetooth, any paired Bluetooth device will reconnect automatically. **Note: Reconnecting time may differ by different devices.**

Maximizing Signal

A Bluetooth signal has a range of up to 30 feet. Keep in mind that Bluetooth is a compressed audio format, so streamed music may lose some integrity when compared to a wired connection.

Try the following if your sound quality is less than optimal:

If you hear any break-up or disconnect while streaming music from your device, move the source device closer to the Sound Bar.

Be sure that there are no solid obstructions in the line-of-sight between the Sound Bar and the source device.

Other wireless devices can affect Bluetooth range, including wireless security cameras, wireless video baby monitors, cordless phones, and microwave ovens. Turning off or moving these devices may improve Bluetooth range.

BLUETOOTH PAIRING

To pair the Soundbar with a Bluetooth device:

1. Press the Bluetooth () button on the remote control. The LED display on the soundbar will display "BT" blinking. The Soundbar Bluetooth pairing will be discoverable for 15 minutes.
Note: Set your Bluetooth device into pairing mode prior to pairing with the Soundbar.
2. You can now search for the Soundbar (SHOCKWAVE) using your Bluetooth device. For more information, refer to the user documentation that comes with the device.
3. Press audio from your Bluetooth device. Volume can be controlled on your source device and Soundbar remote control.

Note: If the soundbar detects the Bluetooth device previously connected, the Soundbar automatically connects to the Bluetooth device after Step 1

To disconnect the Soundbar with a paired Bluetooth device:

1. Hold down the Bluetooth () button on the remote control. The LED display on the soundbar will display "BT" blinking. The Soundbar is ready to pair with a new device.



Your Sound Bar is not equipped with a microphone, so it cannot operate as a hands-free device for a smartphone.



Reduce the volume levels on your device and on the Sound Bar before pressing Play. High volume levels can damage your hearing.

RE-LINKING THE SUBWOOFER WITH THE SOUNDBAR

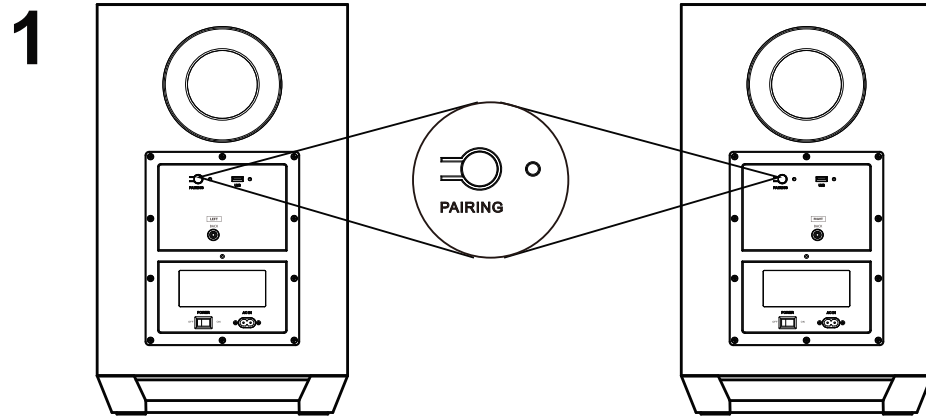
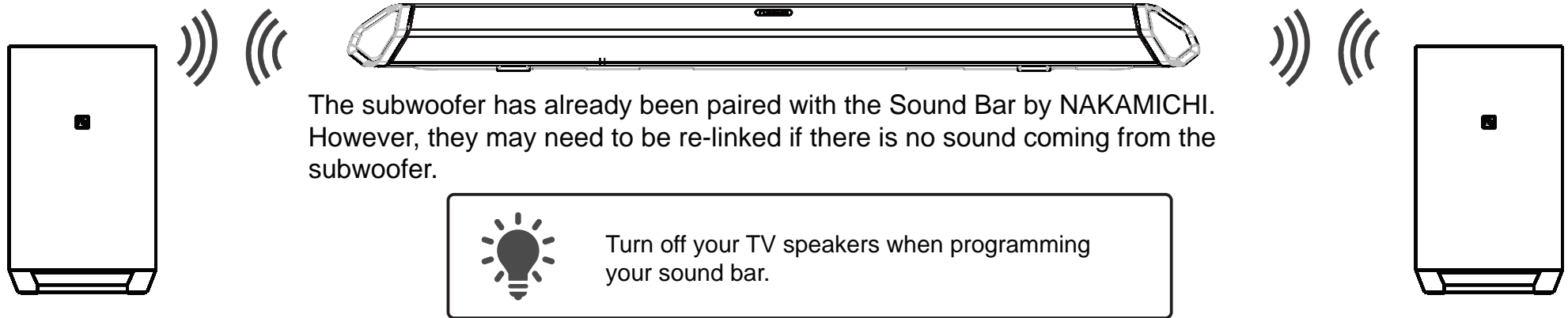

Ensure that the Soundbar is switched OFF. On the two Subwoofers, first confirm that the power switches are in the ON position at the back of the LEFT Subwoofer and then the RIGHT Subwoofer. Press the PAIRING button on the LEFT and then the RIGHT Subwoofer. The BLUE LED on the back of the two subwoofers will begin to blink.

- 2** Power and switch ON the soundbar.
- 3** Switch to USB mode, press and hold the DEMO button for 5 seconds. **OR** Using the remote control, (a) Switch to USB mode, (b) Toggle the MENU button to "SUB PAIR" and (c) Press ENTER. The LED display on the Soundbar will display "SUB PAIR" then "PAIR-". Once the linking is completed, the BLUE LED on the back of the two subwoofers will light up continuously. The two subwoofers are now linked with the Soundbar.

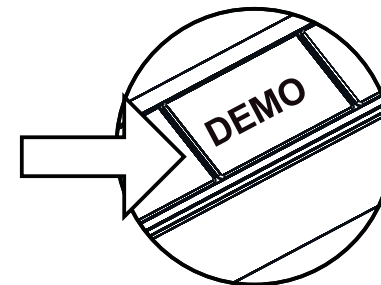

WALL - MOUNTING THE SOUND BAR

1

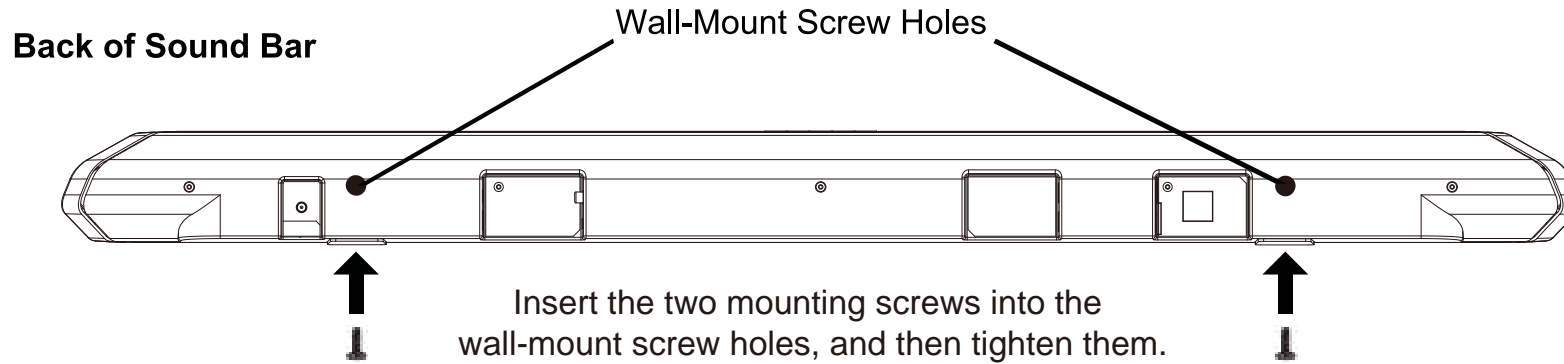

2

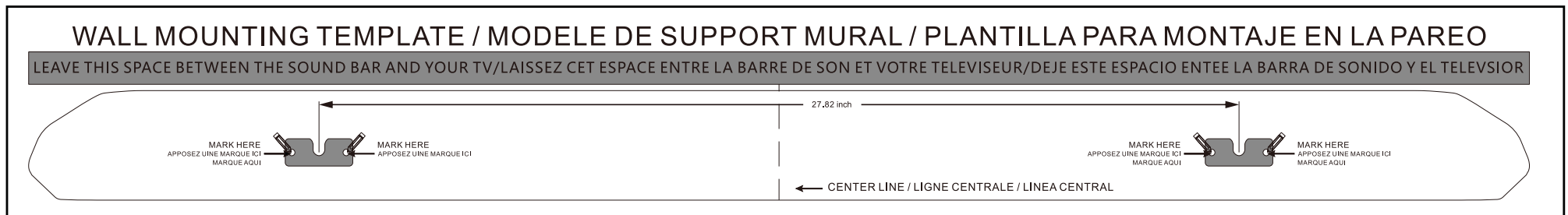

Place the included wall mounting template against the wall under your TV. Mark the four bracket holes using a pencil.

- 3** Be sure your screws are attached to wood studs, drywall anchors (for drywall), or concrete anchors (for brick/concrete walls).

Choose the screw type and length appropriate to your home's construction. If in doubt, consult a professional installer.



If you are unfamiliar with power tools or the layout of electrical wiring in the walls of your home, consult a professional installer.

Wall Mount Screw
Screw Size: M4 x 10

WALL - MOUNTING THE SATELLITE SPEAKERS

To wall-mount the satellite speakers:

1. Attach the mounting screws to the back of the satellite speaker.
2. Align and mount the satellite speaker with the wall mount barcket.

Be sure your screws are attached to wood studs or drywall anchors (for drywall) or concrete anchors (for brick/concrete walls). Wall mounting hardware is not included.



If you are unfamiliar with power tools or the layout of electrical wiring in the walls of your home, consult a professional installer.

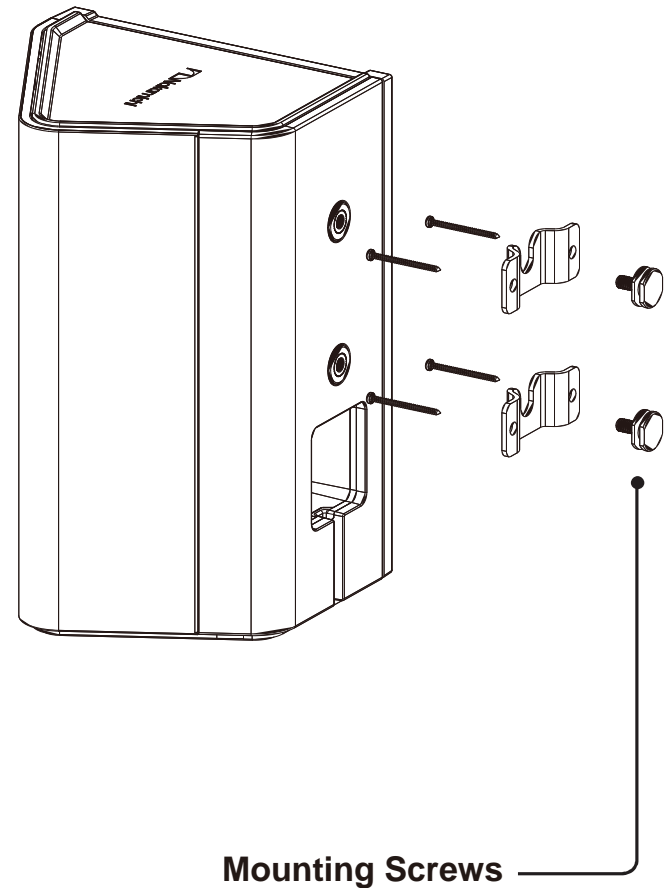

FIRMWARE UPGRADE

New firmware that provides additional features or product improvements will be release as needed. Firmware updates can be downloaded at www.nakamichi-usa.com/fw

Do not perform this procedure unless firmware update is necessary. Make sure you read the information supplied with the updates before updating the firmware.

Checking the firmware version:

On the remote control toggle the INFO button until the LED display “FW XX”. The firmware version will be displayed.

SOUNDBAR FIRMWARE UPGRADE

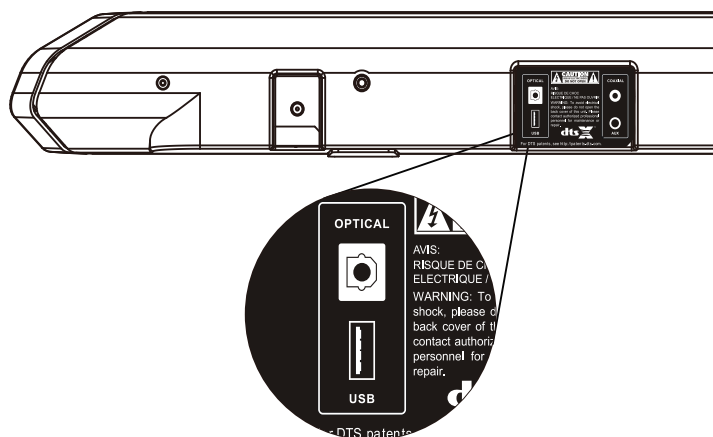

1. Press the USB button on the remote control to USB mode.
2. Insert the USB stick with the unzipped firmware into the Soundbar's USB port.
3. Press and hold the ENTER button.
4. Firmware updating process will be displayed on the LED screen.
5. Once the firmware is completed, the Soundbar will restart automatically.

SUBWOOFER FIRMWARE UPGRADE

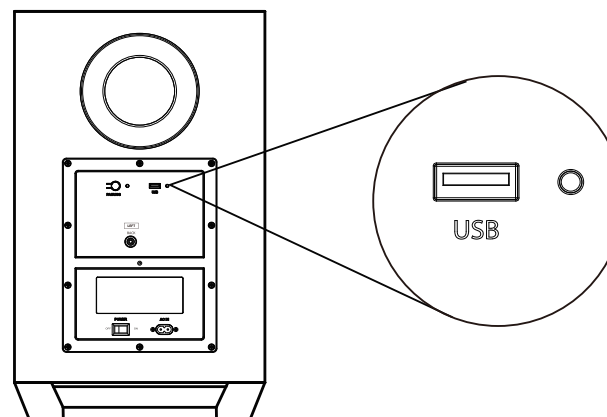

1. Insert the USB stick with the unzipped firmware into the LEFT Subwoofer's USB port.
2. Firmware upgrading will start automatically. The RED LED light will start blinking during the firmware updating process.
3. Once firmware update is completed, the RED LED light will turn off.
4. Repeat step (1) for the RIGHT subwoofer.

*When you perform firmware upgrade, ensure that BOTH the LEFT & RIGHT subwoofer's firmware are upgraded.

UPGRADE PROCESS

SOUNDBAR FIRMWARE UPGRADE

Firmware upgrade process **may take up to 5 to 10 minutes.**

Update progress is displayed on the front panel display when the firmware is upgrading. During each upgrading stage, there will be a numeric percentage to show its progress.

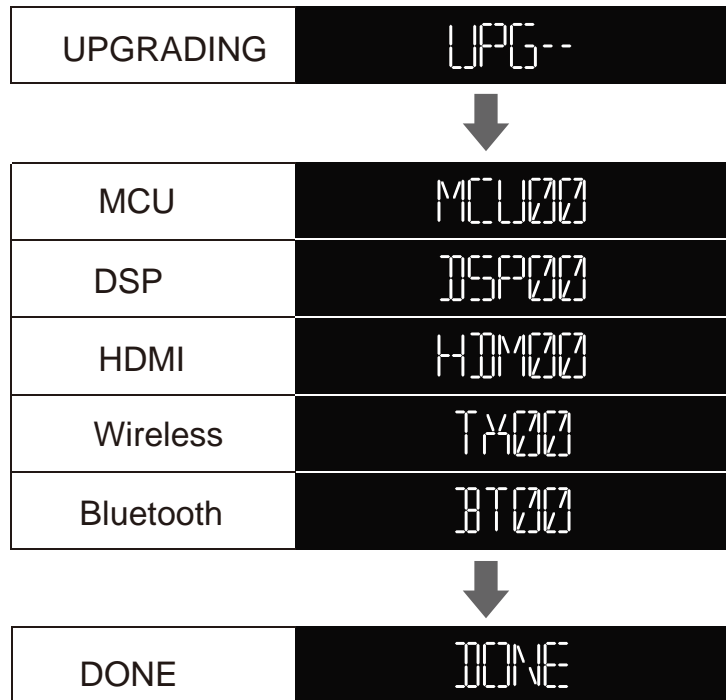

Once the firmware is completed, the Soundbar will restart automatically to factory default setting.

SUBWOOFER FIRMWARE UPGRADE

Firmware upgrade process **may take up to 5 to 10 minutes.**

After inserting the USB stick to the subwoofer's USB port, the subwoofer is accessing the firmware and may takes up to 2 minutes before the RED LED light will starting blinking.

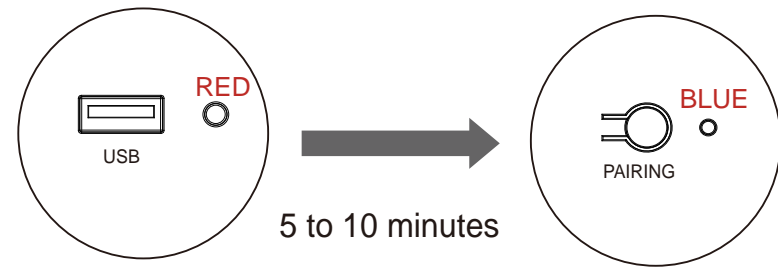

Once the firmware is completed, the RED LED light will turn off, and the BLUE LED next to the Pairing button will light up.

HELP & TROUBLESHOOTING

There is no power.

- Press the POWER button on the remote control or on the top of your Sound Bar.
- Ensure the power cord is securely connected.
- Plug a different device into the electrical outlet to verify that the outlet is working correctly.

There is no sound.

- Increase the volume. Press Volume Up on the remote control or on the top of your Sound Bar.
- Press MUTE on the remote to ensure the Sound Bar is not muted.
- Press SOURCE on the remote or on the top of your Sound Bar to select a different input source.
- When using either of the Digital Inputs, if there is no audio: (A) Try setting the TV output to PCM or (B) Connect directly to your Blu-ray/other source, some TVs do not pass through digital audio.
- Your TV may be set to variable audio output. Confirm that the audio output setting is set to FIXED or STANDARD, not VARIABLE. Consult your TV's user manual for more detailed information.
- If using Bluetooth, ensure that the volume on your source device is turned up and that the device is not muted.

I hear sound cutting out.

- See Page 22 for optimal source device settings.
- Go to www.nakamichi-usa.com/audio-setting for the most updated list.
- Contact: support@nakamichi-usa.com (we guarantee a response within 24 hours.)

The remote isn't working.

- Replace the remote batteries with new ones.
- Point the remote directly at the center of the Sound Bar when pressing a button.
- If using a Bluetooth connection, some of the buttons on the remote may not be supported the streaming application.(e.g., Pandora doesn't support the Back button.)

Resetting the SHOCKWAVE.

- On the remote control, select HDMI ARC mode > Toggle SETUP button to "RESET" > Press ENTER > Select "YES" > Press ENTER.

ONE YEAR LIMITED WARRANTY

Nakamichi LLC (“Nakamichi”) warrants this product against defects in material or workmanship for the time periods and as set forth below. Pursuant to this Limited Warranty, Nakamichi will, at its option, (i) repair the product using new or refurbished parts or (ii) replace the product with a new or refurbished product. For purposes of this Limited Warranty, “refurbished” means a product or part that has been returned to its original specifications. In the event of a defect, these are your exclusive remedies.

Labor: For a period of one (1) year from the original date of purchase of the product (“Labor Warranty”), Nakamichi will, at its option, repair or replace with new or refurbished product, product determined to be defective. If Nakamichi elects to replace the product after this Labor Warranty has expired but while the Parts Warranty below is still in effect, it will do so for the applicable labor charge.

Parts: For a period of one (1) year from the original date of purchase of product (“Parts Warranty”), Nakamichi will supply new or refurbished replacement parts in exchange for parts determined to be defective.

This Limited Warranty covers only the hardware components packaged with the Product. It does not cover technical assistance for hardware or software usage and it does not cover any software products whether or not contained in the Product; any such software is provided “AS IS” unless expressly provided for in any enclosed software Limited Warranty. Please refer to the End User License Agreements included with the Product for your rights and obligations with respect to the software.

CUSTOMER SUPPORT

Thank you for your purchase of this Product.

If you have any questions or comment, please visit our website at www.nakamichi-usa.com/faq or email them to support@nakamichi-usa.com

GLOSSARY

This section explains the technical terms used in this user manual.

What is DTS:X Object Based Audio?

With traditional audio technologies, which channels (speakers) should output what types of sounds when creating audio sources was pre-defined. This is called "channel-based audio". In contrast, new audio systems such as DTS:X use a new technology called object-based audio. This technology processes each sound (e.g., the sound of a car or an actor's voice) contained in an audio source as an "object" and memorizes each object's sound changes and positional changes in a sound field to control these changes during playback. The greatest advantage of applying object-based audio to a home surround sound system is the power to control the audio output method based on device features and the number of speakers used for playback.

AUDIO INFORMATION

Dolby Digital

Dolby Digital is a compressed digital audio format developed by Dolby Laboratories, Inc. that supports 5.1-channel audio. This technology is used for audio on most DVD discs.

DTS: X Dialog Control

DTS: X Dialog Control allows you to boost the dialog. This can be useful in noisy environments to help make the dialog more intelligible. People with impaired hearing may also benefit. Note that the content creator may disable the use of this feature in the mix, so that DTS:X Dialog Control may not always be available.

DTS Digital Surround

DTS Digital Surround is a compressed digital audio format developed by DTS, Inc. that supports 5.1-channel audio. This technology is used for audio on most DVD discs.

DTS-HD High Resolution Audio

DTS-HD High Resolution Audio is a compressed digital audio format developed by DTS, Inc. that supports 7.1-channel and 96 kHz/24-bit audio. DTS-HD High Resolution Audio remains fully compatible with the existing multichannel audio systems that support DTS Digital Surround. This technology is used for audio on BD (Blu-ray discs).

DTS-HD Master Audio

DTS-HD Master Audio is an advanced lossless audio format developed to offer a high-definition home theater experience with the quality of the studio master by DTS, Inc. DTS-HD Master Audio can carry up to eight channels of 96 kHz/24-bit audio (up to six channels of 192 kHz/24-bit audio) simultaneously. This technology is used for audio on BD (Blu-ray discs).

DTS:X

DTS:X is the next generation object-based, multi-dimensional audio technology from DTS. Unbound from channels, DTS:X conveys the fluid movement of sound to create an incredibly rich, realistic and immersive soundscape - in front of, behind, beside and above the audience - more accurately than ever before. DTS:X offers the ability to automatically adapt the audio to the speaker layout that best fits the space, from a television's built-in speakers to a home surround theater system to a dozen or more speakers in a commercial cinema. Immerse yourself at www.dts.com/dtsx

Neural:X

Neural:X is the latest downmixing/upmixing and spatial remapping technology from DTS. It is built in to DTS:X to provide upmix of Neural:X-encoded and non-encoded (PCM) data. In DTS:X for Soundbars, Neural:X can produce up to 11.x channels.

PCM (Pulse Code Modulation)

PCM is a signal format under which an analog audio signal is digitized, recorded, and transmitted. This technology is the basis of all other audio format. This technology is used as a lossless audio format called Linear PCM for audio on a variety of media, including CDs and BD (Blu-ray discs).

WMA (Windows Media Audio)

One of the compressed digital audio formats developed by Microsoft Corporation. With psychoacoustic technologies, this compression method achieves a high compression rate. Reportedly, it is capable of compressing data quantity by about 1/20 maintaining a certain level of audio quality.

MP3

One of the compressed digital audio format used by MPEG. With psychoacoustic technologies, this compression method achieves a high compression rate. Reportedly, it is capable of compressing data quantity by about 1/10 maintaining a certain level of audio quality.

Lip sync

Video output sometimes lags behind audio output due to the complexity of signal processing caused by an increase in video signal capacity. Lip sync is a technique for automatically correcting the timing lag between audio and video output.

HDMI INFORMATION

HDMI

HDMI (High-Definition Multimedia Interface) is the world-wide standard interface for digital audio/video signal transmission. This interface transmits both digital audio and digital video signals using a single cable without any loss. HDMI complies with HDCP (High-bandwidth Digital Content Protection) and provides a secure audio/video interface. For further information on HDMI, visit the HDMI website at "<http://www.hdmi.org/>".

GLOSSARY

HDCP

HDCP (High-bandwidth Digital Content Protection) is a digital copy protection form that prevents copying of digital contents as it travels across connections (such as HDMI).

HDMI CEC CONTROL

HDMI CEC Control allows you to operate external devices via HDMI. If you connect a TV that supports HDMI CEC control to the Soundbar with an HDMI cable, you can control the Soundbar (such as power and volume) with TV remote control operations.

Operation available from the TV's remote control:

- Standby synchronization
- Volume control including mute.

HDMI SIGNAL

Audio Signals

Audio signal types	Audio signal formats	Compatible media
2ch Linear PCM	2ch, 32-192 kHz, 16/24 bit	CD, DVD-Video, DVD-Audio, etc.
Multi-ch Linear PCM	7ch, 32-192 kHz, 16/24 bit	DVD-Audio, Blu-ray disc, HD DVD, etc.
Bitstream (SD Audio)	Dolby Digital, DTS	DVD-Video, etc.
Bitstream (HD Audio)	Dolby Audio, Dolby Digital, DTS DIGITAL, DTS-HD High Resolution Audio, DTS-HD Master Audio, DTS: X	Blu-ray disc, HD DVD

- Refer to documentation supplied with the playback device, and set the device appropriately.
- To decode audio bitstream signals on this unit, set the input source device appropriately so that the device outputs the bitstream audio signals directly. Refer to documentation supplied with the device for details.

This Soundbar is compatible with the follow resolutions:

• VGA	• 720p/60 Hz, 50 Hz
• 480i/60 Hz	• 1080i/60 Hz, 50 Hz
• 480p/60 Hz	• 1080p/60 Hz, 50 Hz, 30 Hz, 25 Hz, 24 Hz
• 576i/50 Hz	• 4K/60 Hz, 50 Hz, 30 Hz, 25 Hz, 24 Hz
• 576p/50 Hz	

HDMI (ARC)

Audio signal types	Audio signal formats	Compatible media
2ch Linear PCM	2ch, 32-96 kHz, 16/24 bit	TV
Bitstream (5.1ch)	Dolby Digital, DTS Digital	TV

DIGITAL AUDIO SIGNAL

• OPTICAL/COAXIAL

Audio signal types	Audio signal formats	Compatible media
2ch Linear PCM	2ch, 32-96 kHz, 16/24 bit	CD, DVD-Video, DVD-Audio, etc.
Bitstream (5.1ch)	Dolby Digital, DTS Digital	DVD-Video, etc.

What is aptX™?

Qualcomm® aptX™ audio technology enhances the wireless sound quality of many of the world's finest smartphones, speakers, headphones and tablets. Previously, these devices often had a reputation for providing average quality sound via Bluetooth, but with aptX, Bluetooth-enabled products can overcome that barrier and consistently deliver higher quality audio wirelessly.

aptX is a key product differentiator in products—where the ability to have a true audiophile experience is paramount.

SPECIFICATIONS

SOUNDBAR DRIVERS

Left & Right

2 x 2.5" Full Range Drivers

Center

2 x 2.5" Full Range Drivers

Surround Left & Right

2 x 2.5" Full Range Drivers

2 x 1" High Frequency Tweeter

SATELLITE DRIVERS

Surround Back Left & Right

1 x 3" Full Range Drivers (Each side)

1 x 1" High Frequency Tweeter (Each side)

WIRELESS SUBWOOFER

1 x 8" Down-Firing Driver (Each side)

PERFORMANCE

Channels: 7.2 Discreet

Sound Pressure Level SPL: 106 dB

RMS Power: 220 W

Frequency Response: 35Hz – 20 kHz

Peak Powering Handling: 800 W

REMOTE CONTROL

52 Keypads, Backlit LED

6 EQ Modes – Movie, Music, Sports, News,

Game, Clear Voice.

CONNECTIVITY

HDMI Out (ARC to TV) x 1 [HDCP 2.2]

HDMI Input x 3 (4K HDR Pass Thru) [HDCP 2.2]

OPTICAL Input x 1

COAXIAL Input x 1

Analog AUX Audio Input x 1

BLUETOOTH 4.1, aptX

USB x 1

AUDIO PROCESSING

Dolby Audio

DTS Digital

DTS-HD High Resolution Audio

DTS-HD Master Audio

DTS: X

DIMENSIONS, WEIGHT & POWER

Soundbar: 45.5 x 3.3 x 3.0 Inch, 7.27 lb.

Subwoofer: 9.5 x 12 x 20.5 Inch, 19 lb. Each

Satellite: 5.0 x 5.4 x 8 Inch, 2.8 lb. Each

RMS Power Output:

90 W (Soundbar)

15W x 2 (Satellite Speakers)

50W x 2 (Subwoofer)

Voltage

Soundbar: 100 – 240V, 50/60 Hz

Subwoofer: 110 - 240V, 50/60Hz

LEGAL & COMPLIANCE

FCC Class B Radio Interference Statement

NOTE: This equipment has been tested and found to comply with the limits for a Class B digital device, pursuant to Part 15 of the FCC Rules. These limits are designed to provide reasonable protection against harmful interference in a residential installation. This equipment generates, uses and can radiate radio frequency energy and, if not installed and used in accordance with the instructions, may cause harmful interference to radio communications.

However, there is no guarantee that interference will not occur in a particular installation. If this equipment does cause harmful interference to radio or television reception, which can be determined by turning the equipment off and on, the user is encouraged to try to correct the interference by one or more of the following measures:

1. Reorient or relocate the receiving antenna.
2. Increase the separation between the equipment and receiver.
3. Connect the equipment into an outlet on a circuit different from that to which the receiver is connected.
4. Consult the dealer or an experienced radio/TV technician for help.

This device complies with Part 15 of the FCC Rules. Operation is subject to the following two conditions: (1) this device may not cause harmful interference, and (2) this device must accept any interference received, including interference that may cause undesired operation.

Warning: Changes or modifications to this unit not expressly approved by the party responsible for compliance could void the user's authority to operate the equipment.

Notice:

1. The changes or modifications not expressly approved by the party responsible for compliance could void the user's authority to operate the equipment.
2. Shielded interface cables and AC power cord, if any, must be used in order to comply with the emission limits.
3. The manufacturer is not responsible for any radio or TV interference caused by unauthorized modification to this equipment. It is the responsibilities of the user to correct such interference.

RF Exposure Information

This device meets the government's requirements for exposure to radio waves. This device is designed and manufactured not to exceed the emission limits for exposure to radiofrequency (RF) energy set by the Federal Communications Commission of the U.S. Government. This device complies with FCC radiation exposure limits set forth for an uncontrolled environment.

Disposal and Recycling

You must dispose of this product properly, according to local laws and regulations. Because this product contains electronic components and a battery, it must be disposed of separately from household waste. Contact local authorities to learn about disposal and recycling options.



Manufactured under license from Dolby Laboratories. Dolby, Dolby Audio, and the double-D symbol are trademarks of Dolby Laboratories.



For DTS patents, see <http://patents.dts.com>. Manufactured under license from DTS Licensing Limited. DTS, the Symbol, DTS in combination with the Symbol, DTS:X, and the DTSX logo are registered trademarks or trademarks of DTS, Inc. in the United States and/or other countries. © DTS, Inc. All Rights Reserved.



The terms HDMI and HDMI High-Definition Multimedia Interface, and the HDMI Logo are

trademarks or registered trademarks of HDMI Licensing Administrator, Inc. in the United States and other countries.



The Bluetooth® word mark and logos are registered trademarks owned by Bluetooth SIG, Inc. and any use of such marks by Nakamichi LLC is under license. Other trademarks and trade names are those of their respective owners.



Qualcomm aptX is a product of Qualcomm Technologies International, Ltd. Qualcomm is a trademark of Qualcomm Incorporated, registered in the United States and other countries, used with permission. aptX is a trademark of Qualcomm Technologies International, Ltd., registered in the United States and other countries, used with permission.

STOP
PLEASE DO NOT
RETURN THIS UNIT

Talk to a SHOCKWAVE PRO sound bar specialist
support@nakamichi-usa.com
For web support, please visit: www.nakamichi-usa.com/faq

24HRS OR LESS
RESPONSE TIME
GUARANTEED

Safety information

IMPORTANT INFORMATION - PLEASE READ CAREFULLY

1 Notice

This section contains the legal and trademark notices.

1.1 Notice of Compliance

This device complies with Part 15 of the FCC Rules. Operation is subject to the following two conditions:

- (1) this device may not cause harmful interference, and
- (2) this device must accept any interference received, including interference that may cause undesired operation.

FCC rules

This equipment has been tested and found to comply with the limits for a Class B digital device, pursuant to part 15 of the FCC Rules. These limits are designed to provide reasonable protection against harmful interference in a residential installation. This equipment generates uses and can radiate radio frequency energy and, if not installed and used in accordance with the instruction manual, may cause harmful interference to radio communications. However, there is no guarantee that interference will not occur in a particular installation. If this equipment does cause harmful interference to radio or television reception, which can be determined by turning the equipment off and on, the user is encouraged to try to correct the interference by one or more of the following measures:

- Relocate the receiving antenna.
- Increase the separation between equipment and receiver.
- Connect the equipment into an outlet on a circuit different from that to which the receiver is connected.
- Consult the dealer or an experienced radio/TV technician for help.

FCC Radiation Exposure Statement:

This equipment complies with FCC radiation exposure limits set forth for an uncontrolled environment. This equipment should be installed and operated with a minimum distance of 20cm between the radiator and your body. This transmitter must not be co-located or operated in conjunction with any other antenna or transmitter.

FCC Warning: Any changes or modifications made to this device that are not expressly approved by Q Acoustics may void the user's authority to operate the equipment.

Canada:

CAN ICES-3 (B)/NMB-3(B)

The device meets the exemption from the routine evaluation limits in section 2.5 of RSS 102 and compliance with RSS-102 RF exposure, users can obtain Canadian information on RF exposure and compliance.

This transmitter must not be co-located or operating in conjunction with any other antenna or transmitter.

This equipment should be installed and operated with a minimum distance of 20cm between the radiator and your body.

This device complies with Industry Canada licence-exempt RSS standard(s).

Operation is subject to the following two conditions:

- a) This device may not cause harmful interference, and
- b) This device must accept any interference received, including interference that may cause undesired operation.

2 Important

Read and understand all instructions before you use your Soundbar. If damage is caused by failure to follow instructions, the warranty does not apply.

2.1 Important safety instructions

- Read these instructions.
- Keep these instructions.
- Heed all warnings.
- Follow all instructions.
- Do not use this apparatus near water.
- Clean only with dry cloth.
- Do not block any ventilation openings. Install in accordance with the manufacturer's instructions.
- Do not install near any heat sources such as radiators, heat registers, stoves, or other apparatus (including amplifiers) that produce heat.
- Do not defeat the safety purpose of the polarized or grounding-type plug. A polarized plug has two blades with one wider than the other. A grounding type plug has two blades and a third grounding prong. The wide blade or the third prong is provided for your safety. If the provided plug does not fit into your outlet, consult an electrician for replacement of the obsolete outlet.
- Protect the power cord from being walked on or pinched, particularly at plugs, convenience receptacles, and the point where they exit from the apparatus.
- Only use attachments / accessories specified by the manufacturer.



- Use only with the cart, stand, tripod, bracket or table specified by the

manufacturer, or sold with the apparatus. When a cart is used, use caution when moving the cart / apparatus combination to avoid injury from tip-over.

- Unplug this apparatus during lightning storm or when unused for long periods of time.
- Refer all servicing to qualified service personnel. Servicing is required when the apparatus has been damaged in any way, such as power-supply cord or plug is damaged, liquid has been spilled or objects have fallen into the apparatus, the apparatus has been exposed to rain or moisture, does not operate normally, or has been dropped.
- Battery usage CAUTION – To prevent battery leakage which may result in bodily injury, property damage, or damage to the unit:
 - ❗ Install all batteries correctly, + and - as marked on the unit.
 - ❗ Remove batteries when the unit is not used for a long time.
 - ❗ The batteries (battery pack or batteries installed) shall not be exposed to excessive heat such as sunshine, fire or the like.
 - ❗ Perchlorate Material - special handling may apply. See www.dtsc.ca.gov/hazardouswaste/perchlorate.
 - ❗ WARNING - DO NOT INGEST BATTERY, CHEMICAL BURN HAZARD.
 - ❗ CAUTION: Danger of explosion if battery is incorrectly replaced. Replace only with the same or equivalent type.
 - ❗ This product / remote control contain a coin / button cell battery. If the coin/button cell battery is swallowed, it can cause severe internal burns in just 2 hours and can lead to death. Keep new and used batteries away from children. If the battery compartment does not close securely, stop using the product and keep it away from children. If you think batteries might have been swallowed or placed inside any part of the body, seek immediate medical attention
 - ❗ Apparatus shall not be exposed to dripping or splashing.
 - ❗ Do not place any sources of danger on the apparatus (for example: liquid filled objects, lighted candles).
 - ❗ Where the MAINS plug or an appliance coupler is used as the disconnect device, the disconnect device shall remain readily operable.
 - ❗ Do not place this apparatus on the furniture that is capable of being tilted by a child and an adult leaning, pulling, standing or climbing on it. A falling apparatus can cause serious injury or even death.
- Never use a gas duster for this apparatus. The gas trapped inside of this unit may cause ignition and explosion.

Class II equipment symbol



This symbol indicates that the unit has a double insulation system.



This 'bolt of lightning' indicates uninsulated material within your unit may cause an electrical shock. For the safety of everyone in your household, please do not remove product covering. The 'exclamation point' calls attention to features for which you should read the enclosed literature closely to prevent operating and maintenance problems.

- WARNING: To reduce the risk of fire or electric shock, this apparatus should not be exposed to rain or moisture and objects filled with liquids, such as vases, should not be placed on this apparatus.
- CAUTION: To prevent electric shock, match wide blade of plug to wide slot, fully insert.

2.2 Care of the environment



Your product is designed and manufactured with high quality materials and components, which can be recycled and reused. Never dispose of your product with other household waste. Please inform yourself about the local rules on the separate collection of electrical and electronic products and batteries. The correct disposal of these products helps prevent potentially negative consequences on the environment and human health. The batteries supplied do not contain the heavy metals mercury and cadmium.

Nevertheless, in many areas batteries may not be disposed of with your household waste. Please ensure you dispose of batteries according to local regulations. For perchlorate material, special handling may apply. Visit www.dtsc.ca.gov/hazardouswaste/perchlorate.

Le présent appareil est conforme aux CNR d'Industrie Canada applicables aux appareils radio exempts de licence. L'exploitation est autorisée aux deux conditions suivantes :

- (1) l'appareil ne doit pas produire de brouillage,
- (2) l'utilisateur de l'appareil doit accepter tout brouillage radioélectrique subi, même si le brouillage est susceptible d'en compromettre le fonctionnement.

Le dispositif rencontre l'exemption des limites courantes d'évaluation dans la section 2.5 de RSS 102 et la conformité à l'exposition de RSS-102 rf, utilisateurs peut obtenir l'information canadienne sur l'exposition et la conformité de rf.