



DTU-710 SAFETY INSTRUCTIONS

INTERACTIVE PEN DISPLAY

WARNING

Do not use DTU-710 Interactive Pen Display in a facility control system that requires extremely high reliability; it may cause other electronic devices to malfunction, or other devices may cause DTU-710 to malfunction.

Where use is prohibited, power off DTU-710 to prevent the possibility of it causing other electronic devices to malfunction. Wacom does not accept any liability for direct or consequential damages. For details, please refer to your Warranty, located at the inside back cover of this manual.



HIGH VOLTAGE

Do not open DTU-710. It has the risk of electric shock.

Only use the AC adaptor that came with DTU-710. If a different type of AC adaptor is used, DTU-710 will not work properly or it may be damaged. ***Using a different type of AC adaptor also has the potential to result in fire.*** Use of a different AC adaptor will void your warranty.

CAUTION

Prevent your children from swallowing the pen nib or side switch knob. The pen nib or side switch knob may accidentally be pulled out if children are biting on them.

If the LCD screen has been damaged, DO NOT touch any liquid that may be leaking from it; this liquid is an irritant. In case of contact with skin, eyes, or mouth, rinse immediately with running water for at least 15 minutes or more. If contact is made with the eyes or mouth, also consult a physician.

When adjusting the tilt angle of DTU-710, be careful to avoid catching your finger in the gap of the movable portion of the stand.

Be sure to use a grounded power source when applying power to DTU-710.



Introduction and Overview

The Wacom® DTU-710™ Interactive Pen Display combines an LCD monitor with a Wacom tablet.

This gives you a direct point-and-draw-on-screen interface that can be used with a Personal Computer (PC) or Macintosh computer. DTU-710's basic components include a Wacom tablet internally mounted behind a 17.0" diagonal TFT color LCD monitor, and Wacom's pen.

Your DTU-710 Interactive Pen Display offers a number of significant advantages over a standard monitor:

- Reduced power consumption
- Reduced heat generation
- Requires less work space
- Flicker free and easier on the eyes
- Integrated input and display
- Pressure-sensitive drawing directly on the display screen.

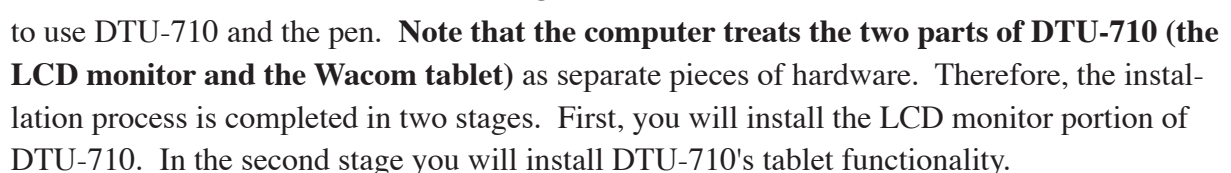

This manual describes how to install DTU-710 hardware and software. It also describes how to use DTU-710 and the pen. **Note that the computer treats the two parts of DTU-710 (the LCD monitor and the Wacom tablet)** as separate pieces of hardware. Therefore, the installation process is completed in two stages. First, you will install the LCD monitor portion of DTU-710. In the second stage you will install DTU-710's tablet functionality.

You can find information on using the Wacom Tablet Control Panel for customizing your tablet and pen settings in the online Help, located under the **Help** menu in the Wacom Tablet Control Panel.

The following are not included with this product:

- Information about your specific computer hardware
- Information about your operating system
- Information about application software.

Please refer also to your computer hardware, operating system, or software application manuals.

To use the pressure-sensitivity of the pen with your favorite drawing application, refer to instructions in that application's manuals.

Precautions on Use and Handling

Be sure to follow all instructions, cautions, and warnings found within this manual. Failure to do so could cause the loss of data or damage of your computer. Failure to do so could also void your warranty, in which case Wacom shall have no responsibility for such loss or damage and to repair or replace the product.

- **Do not lift DTU-710 by the stand;** this may damage the stand mechanism. When lifting or moving DTU-710, always do so by grasping the main body casing.
- **Do not put heavy articles on DTU-710;** this may damage the display screen or stand.
- **Do not place heavy article on DTU-710 cabling, repeatedly bend the cables, or apply heavy stress on the cable connectors;** this may damage the unit or your cabling.
- **Do not connect or disconnect the DVI video cable or power cable while DTU-710 and your computer is turned on;** it may damage the LCD display or computer video card.

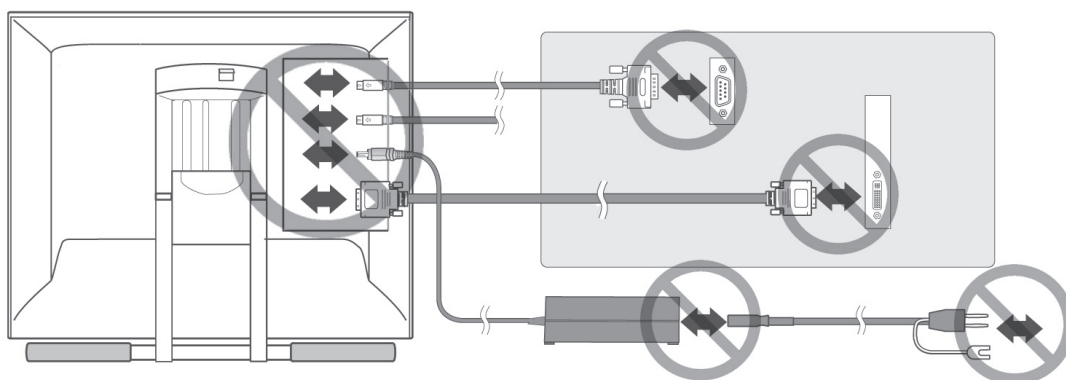

- **This product is for use with a VGA or DVI graphics card;** using an inappropriate graphics card may damage DTU-710.
- **Do not disassemble DTU-710 or pen.** This may cause DTU-710 or pen to malfunction. In this case, Wacom shall have no responsibility to repair or replace the product.
- **Do not use or store DTU-710 where:**
 - Temperature changes are severe (e.g., outdoors or inside a vehicle).
 - DTU-710 and pen are exposed to direct sunlight or heat from a heating appliance.
 - DTU-710 and pen are exposed to water or any other kind of liquid.
 - Temperature or humidity exceeds the specifications.
- **Do not block the ventilation holes in the rear panel;** this may overheat and damage DTU-710.
- **Do not use DTU-710 in a dusty environment;** It may damage the unit.
- **Do not scratch the cover glass of DTU-710.** Avoid placing sharp objects on the glass surface.
- **Do not use detergent to clean the cover glass of DTU-710;** this may alter the surface friction and deteriorate the handwriting feel.

Table of Contents

Checking Packed Components	5
Installation	6
LCD Monitor Installation	
Tablet Software Installation for Windows and Macintosh	
Customizing DTU-710 - The Basics	8
Opening the Wacom Tablet Control Panel	
Calibrating the Tablet	
DTU-710 Component Functions	10
Front View	
Rear View	
Using an Alternate Mount or Stand	
Using the Pen	13
Pen	
Using a Pen	
Remouing the side switch	
Adjusting the LCD Monitor	15
Factory Presets, Multi-Cync, and User Settings	
Working with OSD (On Screen Display) Menu	
Adjusting Pitch and Phase	
Power Saving	
Caring For Your DTU-710	19
Cleaning	
Replacing the Pen Tip	
Display Troubleshooting	20
Obtaining Technical Support	22
Specifications	23
General Specifications	
LCD Display	
Tablet	
Power Adaptor	
Pen	
Pen Accessories	
Warranty on Sales in Asia-Pacific area	Inside Back Cover

Checking Packed Components

In your package you will find the following items:

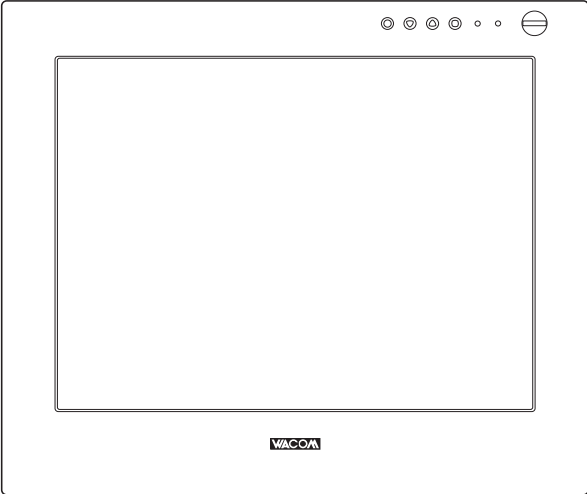

DTU-710 main unit

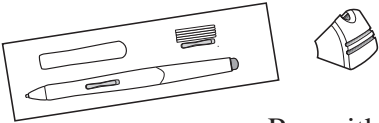

Pen with Pen Stand

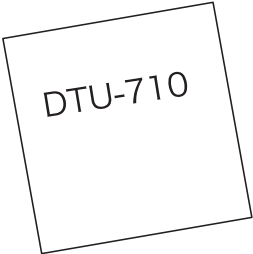

User's Manual

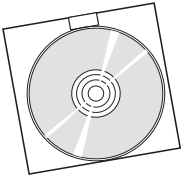

Wacom Tablet CD
Contains the driver software.
(Windows/Macintosh)

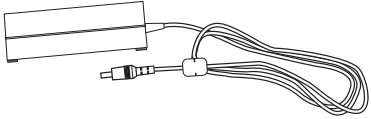

AC Adaptor and Cable

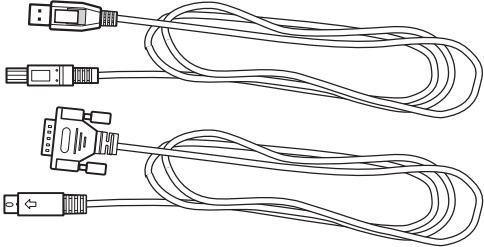

USB Cable and RS-232C Cable*

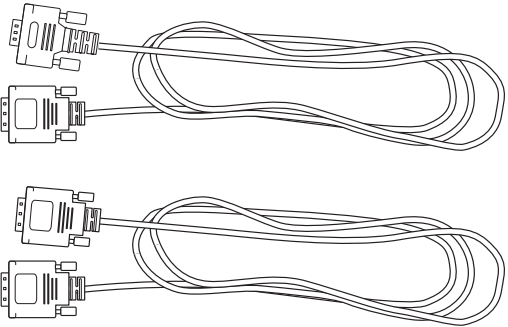

DVI-DVI Cable and DVI-VGA Cable*

Some package configurations include an additional CD containing bundled software applications.

Please retain the package box for use when storing or shipping DTU-710.

* For DTU-710 only. Do not use with other devices.

Installation

LCD Monitor Installation

First install the monitor portion of DTU-710. Do not connect the USB cable or serial data cable until you proceed to the step "⑨".

① Turn off your computer.

IMPORTANT: Never connect or disconnect the DVI video cable or power cable while your computer or DTU-710 is powered on. This can damage the LCD display or video card.

② Connect the DVI-to-DVI cable or DVI-to-VGA cable between DTU-710 and your computer.

③ Set the DVI/VGA switch. Move it up for analog (VGA) mode, and move it down for digital (DVI) mode.

④ Connect the AC adaptor to DTU-710.

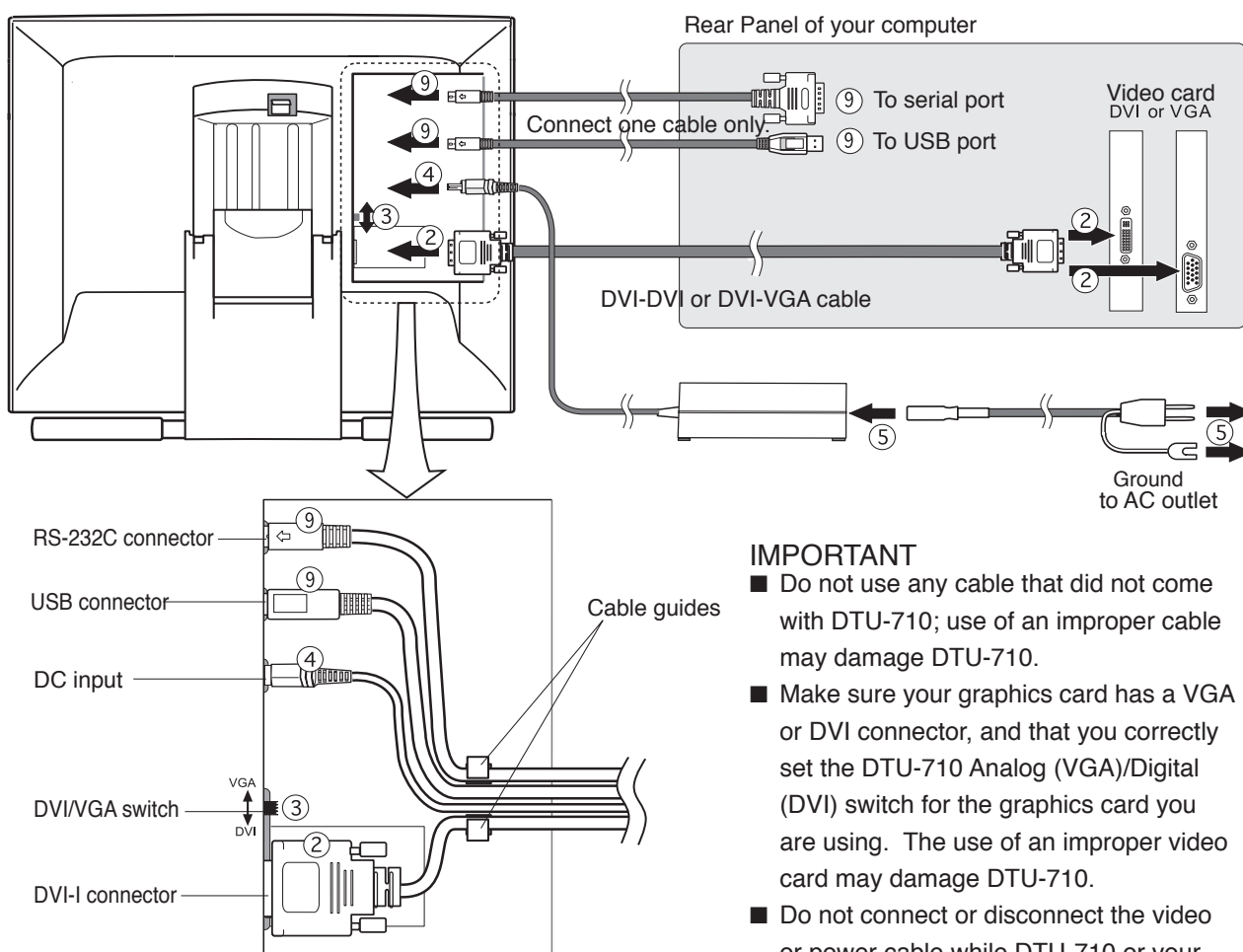

IMPORTANT

- Do not use any cable that did not come with DTU-710; use of an improper cable may damage DTU-710.
- Make sure your graphics card has a VGA or DVI connector, and that you correctly set the DTU-710 Analog (VGA)/Digital (DVI) switch for the graphics card you are using. The use of an improper video card may damage DTU-710.
- Do not connect or disconnect the video or power cable while DTU-710 or your computer are turned on; this can damage the LCD display or computer video card.

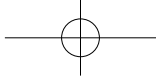

-
- ⑤ Connect the AC adaptor power cable and plug the adaptor into an AC outlet.
 - ⑥ Turn on the power switch of DTU-710. The power lamp will light blue, and then turns orange.
 - ⑦ Turn on your computer to start your operating system.
 - ⑧ The maximum resolution of DTU-710 is 1280 x 1024, True Color (24 bit). As necessary, configure the monitor control panel settings for the proper size and color resolution.
The number of colors is constrained by the performance of your computer or graphics card. Refer to the documentation of the manufacturer for details.
If you are using analog (VGA) mode, you may also want to fine-tune the display. Please refer to Adjusting the LCD Monitor on page 15 for more information.
 - ⑨ To install the Wacom tablet software, turn off your computer and connect the USB cable or serial data cable.

Tablet Software Installation for Windows and Macintosh

- ① After connecting all cables of DTU-710, turn on DTU-710 and your computer. Allow the operating system to fully load.
- ② Insert the Wacom Tablet CD into the CD-ROM drive. The Wacom tablet software installer menu should automatically display. If the menu does not display, double-click on the Install icon (located on the CD). Follow the prompts to install the driver software.
- ③ **Windows:** After the driver installation is complete, make sure you can use your pen on the tablet display to move the screen cursor.

Macintosh: After the driver installation is complete, restart your Macintosh. You will be able to use your pen on the tablet display to move the screen cursor.

Be sure to read the README file for late braking news.

If you have trouble in the Tablet software installation, refer to the *Troubleshooting* chapter in the online Help in the Wacom Tablet CD. You can also open the online Help from the HELP menu from the WACOM TABLET control panel.

Precede to *Customizing Your DTU-710 - The Basics*.

Customizing DTU-710 – The Basics

Opening the Wacom Tablet Control Panel

The Wacom Tablet Control Panel makes it easy to customize your Interactive Pen Display and the pen.

To open the control panel:

Windows: Click on the Windows Start button and choose Programs. From the Wacom Tablet group, choose the Wacom Tablet option.

Macintosh: From the Apple menu, choose Control Panels and then Wacom Tablet.

When you open the control panel, an icon for the pen is displayed in the TOOL LIST and the appropriate tabs are displayed. To customize the pen, make your changes to the tab controls.

On Windows systems, be sure to click APPLY or OK to save your changes.

Note: Application-specific settings are for advanced users. Refer to the online Help for more information on creating and using application-specific settings.

The screenshot shows the 'Wacom Tablet Properties' window. It has a menu bar with 'File', 'Edit', 'Add', 'Remove', 'Language', and 'Help'. Below the menu bar is a section for 'Applications with Customized Tool Settings' with a list box containing 'All Applications' and an 'Add Application to List...' button. Below that is the 'Tool List' with 'UltraPen' selected and an 'Add Tool to List...' button. The main area contains several tabs: 'Eraser Feel', 'Calibration', 'Pop-up Menu', 'Connection', 'Pen Type', 'Tip Feel', 'Double-Click', and 'Tool Buttons'. The 'Pen Type' tab is active, showing 'Soft' and 'Firm' pressure levels, a 'More Options' button, and a 'Draw here' area with a 'Click' button. On the right side, there are buttons for 'Reset Tab to Defaults', 'Revert Tab', and 'Copy Settings To...'. At the bottom right, there are buttons for 'OK', 'Cancel', 'Apply', and 'Help...'. Annotations with lines pointing to these elements include: 'Displays applications with customized set-' pointing to the 'All Applications' list; 'Displays an icon for the pen.' pointing to the 'UltraPen' icon; 'The pull-down menus access a variety of control panel features.' pointing to the menu bar; 'For Windows only: OK saves changes and closes the control panel. CANCEL closes the control panel without saving changes. Use APPLY to save changes without closing the control panel. Displays online Help for the control panel.' pointing to the 'OK', 'Cancel', 'Apply', and 'Help...' buttons; 'Tabs display settings for the selected application.' pointing to the tabs; 'Resets the selected tab to its factory default values' pointing to 'Reset Tab to Defaults'; 'Returns a tab to its previously saved or last applied settings.' pointing to 'Revert Tab'; and 'Copies settings from one tool or application to another.' pointing to 'Copy Settings To...'. The caption below the screenshot reads 'Windows screen capture shown.'

Current selections are highlighted. Wedges emphasize the relationship between tab settings and the selected tool and application.

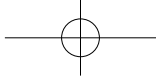

Calibrating the Tablet

You will need to calibrate the tablet in order to line up the screen cursor position with the position of the pen on DTU-710. This is required to adjust for parallax caused by the display screen overlay. After setting the tablet in its working position, follow the procedure below to calibrate the tablet.

- ① From the Wacom Tablet Control Panel, select the Calibration tab.

If you are working with multiple monitors, select the Monitor that corresponds to the tablet's LCD display.

- ② Click on the Calibrate... button to display the monitor calibration screen.



- ③ Hold the pen as you normally do, and use the pen tip to click on the cross-hairs in the upper-left corner.

- ④ Then click on the cross-hairs that are displayed in the lower-right corner. (For Windows systems, you will need to click Apply or OK for the changes to take effect.)

Note: The calibration setting applies to all applications.

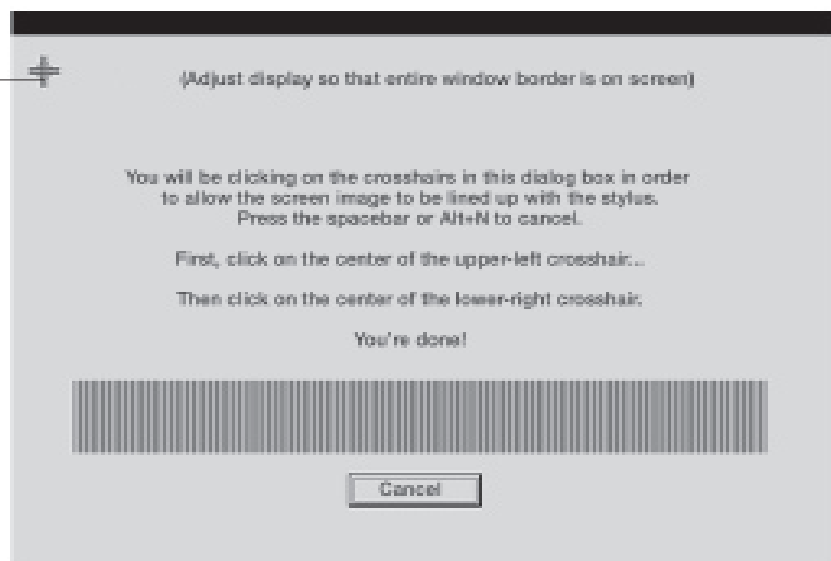

DTU-710 Component Functions

Front View

MENU Button

Opens and closes the OSD^{*1} menu.

- (minus) Button, + (plus) Button

In the OSD^{*1} menu, Use these buttons to select an option that can then be activated. After activating a selected option, press the + button to increase a selected item value, and press the - button to decrease it.

ENTER Button

Press this button when you select or exit an item in the OSD^{*1} menu.  P 15

Power Switch

Turns the power to the unit on or off.

Power Lamp

Lights blue when power and video signals have properly been supplied to DTU-710. Turns orange or flashes when your computer goes into power management mode and stops sending the video signal to DTU-710.

Status Lamp

Lights blue when a pen switch is pressed, or when the eraser enters proximity of the tablet.

Integrated Tablet and LCD Screen

The LCD monitor^{*2} and tablet sensor function^{*3} as an integrated input and output device.

The LCD resolution is 1280 x 1024 pixels at 16,777,216 colors. The tablet sensor reports coordinates, pressure, switch, and eraser information.

*1 On Screen Display.  P. 15

*2 As properties of LCD panel display, you may notice the followings. They do not mean the LCD is defective.

- When exerting hard downward pressure on the display, a moir pattern may temporarily appear.
- A very small number of pixels may appear in incorrect color.
- If an image area has fine striping (such as screen stripes), it may flicker or display a moir pattern or pooling image.
- When a still image is displayed for a long period of time, an afterimage may remain for a short period of time.

*3 As the tablet portion of DTU-710 emits electromagnetic waves at a certain frequency, if another tablet is closely placed to DTU-710, the screen cursor may jitters or jumps around. To solve this problem, place the tablet away from DTU-710.

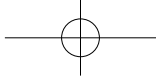

Rear View

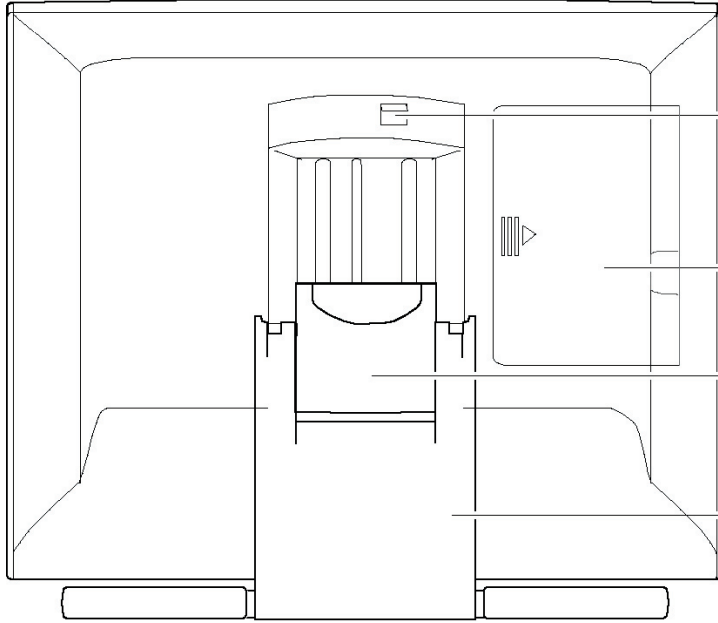

Stand Adjustment Lever
Pull this lever to adjust the stand.
Release the lever to lock the stand in

Connector Panel Cover
To remove, slide it to the right.

⚠ CAUTION
Be careful to avoid catching your finger in the gap of the movable portion of the stand.
Stand

The stand can be used to adjust the tilt angle of the unit from low (16° from horizontal) to high (72° from horizontal).

IMPOTANT

Be sure to adjust the tilt angle of the stand to the low tilt position before packaging DTU-710. If you do not close the stand, the notched mechanism may be damaged during transportation and storage. Do not lift the unit by the stand; this may damage the stand mechanism. When lifting or moving the unit, always do so by grasping the main body casing.



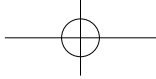

DTU-710 Component Functions

Using an Alternate Mount or Stand

If you will be using DTU-710 in an installation that requires the use of an alternate mounting platform, you can remove the adjustable stand from DTU-710 and mount the pen display onto a VESA conforming mount arm or stand.

A VESA mounting platform will require mount screws that are 4 mm wide with a 0.7 mm pitch (M4 Regular). Exceeding the screw clearance depth of 15 mm will damage DTU-710 internal components.

To remove the adjustable stand and attach DTU-710 to a different mounting platform:

- ① Turn off your computer and power off DTU-710. Then disconnect all cables from DTU-710.
- ② Protect the display screen surface by spreading a soft cloth onto a flat table and placing DTU-710 face down on the cloth.
- ③ Remove the four screws and lift the adjustable stand assembly away from the body of DTU-710.
- ④ Using the appropriate screws for your mounting platform, firmly attach DTU-710 to the alternate mounting platform.
- ⑤ Rettach the cabling.

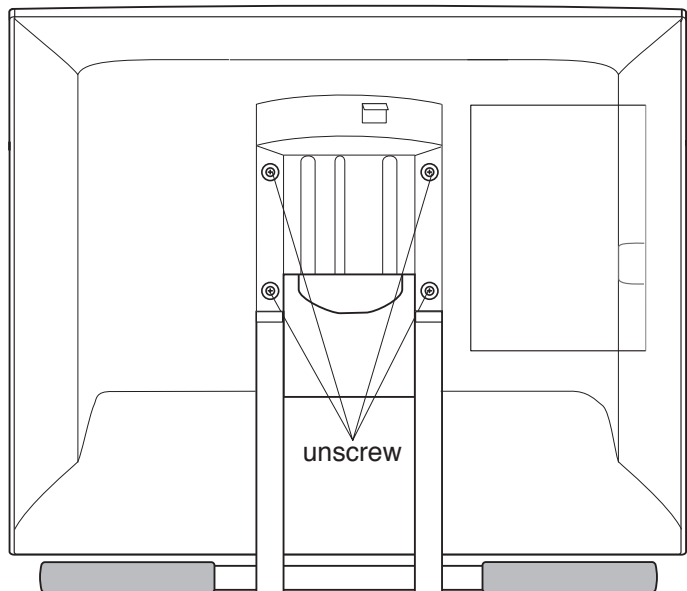

CAUTION

When attaching DTU-710 onto an alternate mounting platform, be sure to follow all instructions in the documentation supplied by the platform manufacturer.

If improperly installed, the unit could fall and be damaged.

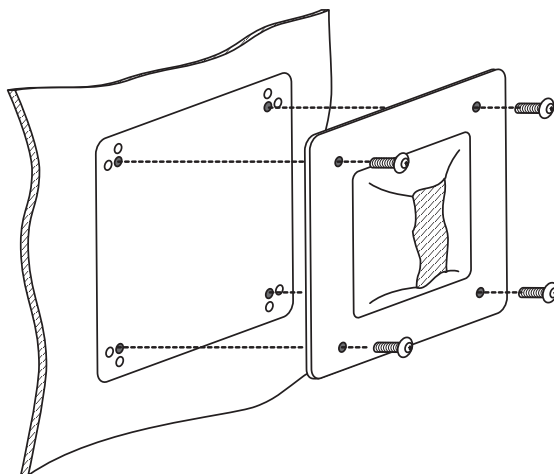

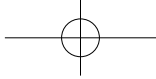

Using the Pen

Pen

Hold the pen as you would a pencil. Make sure the side switch is in a convenient location where you can press it with your thumb or forefinger, but won't accidentally press it while drawing.

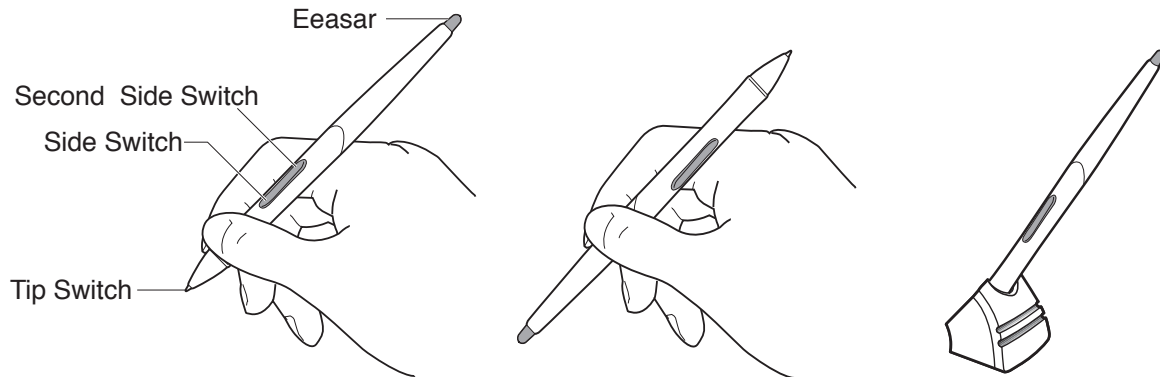

Pen Tip

When the pen tip is within proximity (5 mm or 0.2 in) of the active area, the tablet reports:

- The x, y coordinates of the pen tip.
- The pressure applied to the pen tip.
- Whether a side switch is on or off.

When pressure is applied to the pen tip, the tip switch is turned on and the pen simulates a mouse button click.

Eraser

To use the eraser, hold the pen upside down. When the eraser is within proximity of the active area, the tablet reports the x, y coordinates and the pressure applied to the eraser.

The eraser can be used as an eraser or assigned to another function, depending on the application. The tablet distinguishes the tip switch from the eraser switch.

Side Switch and Second Side Switch

These switches are programmable, and can be used to perform the same click and double-click functions as the tip switch. The switches are turned on when pressed, and are otherwise turned off. Please refer to the online Help for more information on side switch settings.

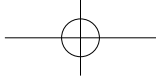

Using the Pen

Using a Pen

Pointing and Selecting

Move the pen above DTU-710 screen to position the screen cursor. The cursor instantly jumps to the new location (absolute positioning). Press the pen tip on DTU-710 screen to make a selection.

Note: If the screen cursor is not aligned with the pen tip, you will need to calibrate DTU-710.

Clicking

Tap DTU-710 screen once with the pen tip, or touch the pen to the display screen with enough pressure to generate a mouse click.

Dragging

Select an object, then slide the pen tip across DTU-710 screen to move the object.

Double-Clicking

Press the upper side switch (Windows systems) or quickly tap DTU-710 screen twice in the same place with the pen tip. Double-clicking is easier when the pen is perpendicular to the tablet screen.

Erasing

In supporting applications, the pen's eraser works like the eraser on a pencil. In text applications, use the eraser to select text, then lift the eraser from the tablet to delete the text.

Removing the Side Switch

If you prefer to remove the side switch:

- 1 Firmly clasp the switch in the middle and pull out. (Press in on the rubberized grip in order to better grasp the switch.)

Important : Do not remove the switch by prying it from either end as this may damage your Pen.

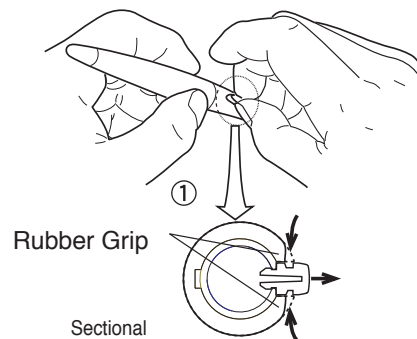

- 2 Remove the pen tip cone by turning it counterclockwise.
- 3 Pull the grip forward over the pen tip. NEVER adjust the trimmer capacitor that became visible as it is fine tuned. When using the pen without the side switch, always install the optional grip in order to protect the trimmer capacitor.
- 4 Install the optional grip by aligning the pen case rails with the grooves inside the grip and pushing the grip over the pen tip.
- 5 Replace the pen tip cone by turning it clockwise onto the pen.

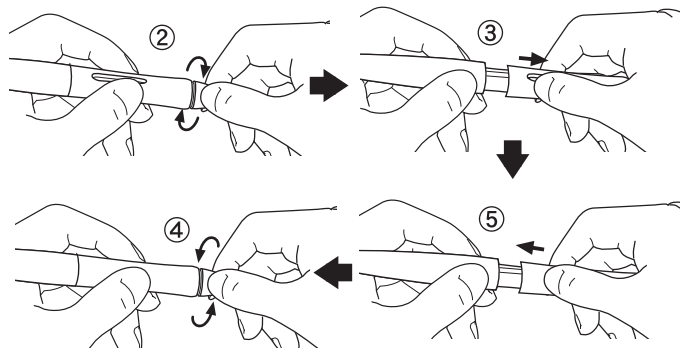

To reinstall the side switch, reverse the above procedure.

Adjusting the LCD Monitor

Factory Presets, Multi-sync, and User Settings

Factory Presets: To display images with the best quality (based on the incoming signal), DTU-710 comes with a number of factory default standard display modes.

Multi-Sync: When connected as a VGA display, DTU-710 attempts to automatically synchronize to the incoming signal. Multi-Sync functions if the horizontal frequency is between 30 to 80 kHz and the vertical frequency is between 50 to 75 Hz. If DTU-710 does not automatically synchronize with the incoming signal, you can use the OSD Reset Auto Adjust option to initiate display synchronization. If necessary, further screen display adjustments can be manually made using the On Screen Display (OSD) controls.

User Settings: When you manually set the display using the On Screen Display (OSD) function, the settings are stored within DTU-710 for use the next time the unit receives a similar signal. This is applicable to all display modes.

Working with OSD (On Screen Display) Menu

To open the main MENU, press the MENU (O) button.

Use the + (Δ) or - (∇) buttons to select an option. When the option you want to adjust is highlighted, press the ENTER (□) button. The current settings and adjustment sub-menu for that option will appear.

Use the + (Δ) or - (∇) buttons to adjust the option settings.

When you have made your changes, press the ENTER (□) button to save. **To exit,** press the MENU (O) button. All settings are automatically saved when the OSD menu closes.

Contrast

Select to increase or decrease image contrast.

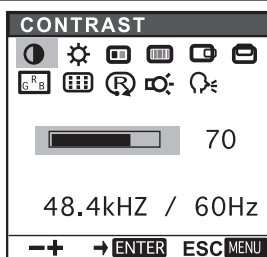

Phase (VGA only)

Select to reduce or eliminate horizontal distortion lines. P17
To automatically adjust, use the RESET option.

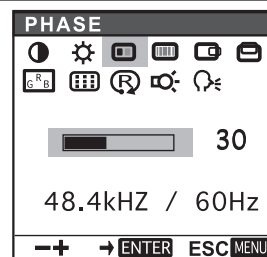

Brightness

Select to increase or decrease image brightness.

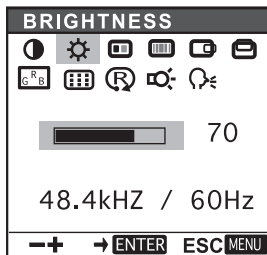

Pitch (VGA only)

Select to reduce or eliminate vertical distortion lines. P17
To automatically adjust, use the Reset option.

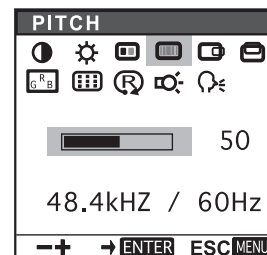

Adjusting the LCD Monitor

Horizontal Center

(VGA only)

Select to move the screen image left or right.

To automatically adjust, use the Reset option.

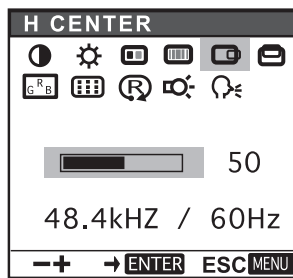

Vertical Center

(VGA only)

Select to move the screen image up or down.

To automatically adjust, use the Reset option.

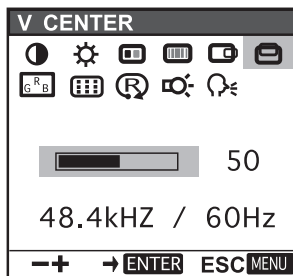

Color

Provides settings for 9300°, 6500°, and 5000° Kelvin.

Also provides a User option that enables you to adjust red, blue and green independently. Selecting DIRECT displays the received signal as it is without any adjustment.

Choose a setting to work with and press Enter to

activate your selection. You can change the user setting by selecting the icon .

In the USER ADJUSTMENT window, change red, blue and green to calibrate color.

To exit, select the icon .

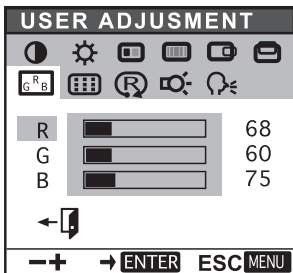
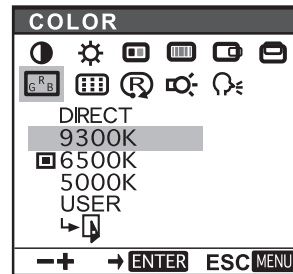

Menu Position

Select to move the OSD menu around the display.

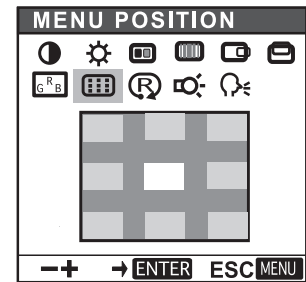

Reset

Provides two options:

Use Auto Adjust to reset only the image parameters. Use Recall to reset all screen options to the factory default.

Selecting the exit () icon exits the Reset window without resetting anything.

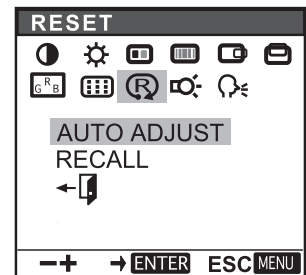

Backlight

Selects to increase or decrease the backlight brightness level.

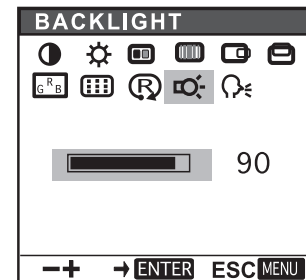

Language

Select to choose a language option for the OSD: English, Deutsch, Francais, Espanol, Italiano, or Japanese.

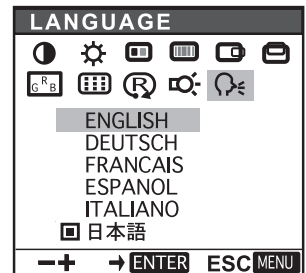

Adjusting Pitch and Phase (VGA only)

Some computers and video cards may not allow the multi-sync function to fully work when DTU-710 is first connected. If some portion of the text appears blurred, adjust the pitch and phase by following the procedure below. For crisp images, set the DTU-710 resolution of your video card to 1280 x 1024.

- ① From the Wacom Tablet Control Panel, select the Calibration tab.

If you are working with multiple monitors, select the Monitor that corresponds to DTU-710.

- ② Click on the CALIBRATE... button to display the monitor calibration screen.

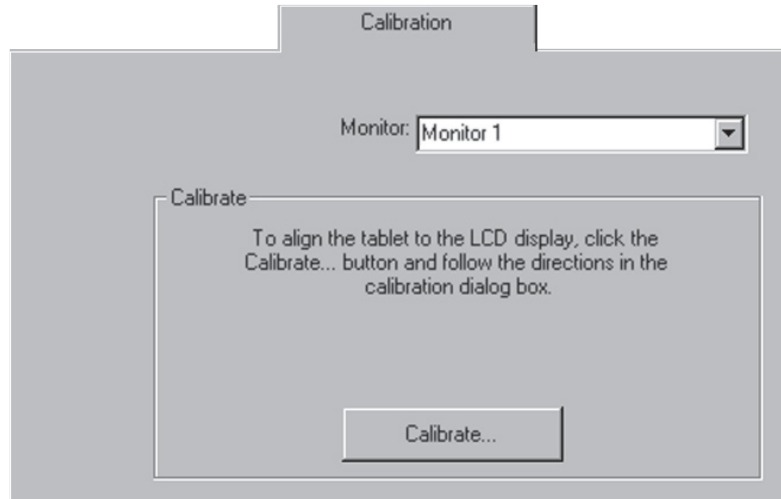

- ③ Open the OSD Menu and select the Pitch icon.

- ④ Adjust the Pitch level so that the the pattern

of fine vertical stripes displays evenly.

- ⑤ In the OSD Menu, select the Phase icon and adjust the Phase level so that the adjustment pattern shows clearly.

- ⑥ After completing the adjustments press the ENTER (⏏) button and MENU (⏏) button to exit the OSD Menu.

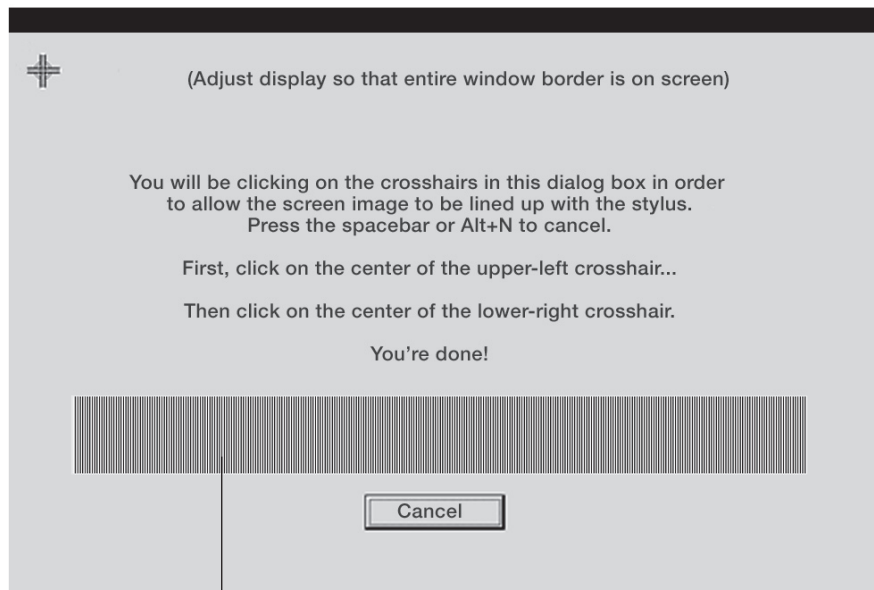

Adjustment pattern

Adjusting the LCD Monitor

HINT (1280 x 1024 resolution under Windows only): You can also adjust Pitch and Phase in the closing Windows display.

If the pitch is not calibrated, vertical moire appears in the darkened area. And if the phase is not calibrated, the darkened area ripples.

Power Saving

DTU-710 conforms to VESA and Energy Star power saving guidelines. When using DTU-710 with a VESA DPMS Display Power Management Signaling (DPMS) compliant computer or graphics card, the display will automatically comply with the below power saving parameters.

Power Saving Mode	H-sync	V-sync	Video	Power Consumption	Power Lamp
Power ON	Yes	Yes	Active	45W max.	Blue
Standby mode	No	Yes	Blanked	5W max.	Orange/Blue
Suspend mode	Yes	No	Blanked	5W max.	Orange/Blue
OFF mode	No	No	Blanked	5W max.	Orange

Caring for DTU-710

Cleaning

To clean the DTU-710 casing, use a soft cloth with mild detergent (such as dish washing liquid) diluted with water. Do not use paint thinner, benzine, alcohol, or other organic solvents to clean DTU-710 casing or pen.

To clean the display screen, use a soft, dry cloth. If necessary, slightly moisten the cloth with water and try again. When cleaning, apply only a light amount of pressure to the display screen and do not make the surface wet. Do not use detergent to clean the display screen; this may damage the coating on the screen. Please note that damage of this kind is not covered by the manufacturer's warranty.

Replacing the Pen Tip

The pen tip will wear with normal use. When the nib gets too short, you can replace it with one of the extra nibs that came with your pen. If the pen tip wears and becomes angular, it may damage the coating on the cover glass of DTU-710 Interactive Pen Display. To avoid this, periodic nib replacement is recommended.



Clasp it with a pair of tweezers or similar instrument and pull the old nib straight out of the pen.

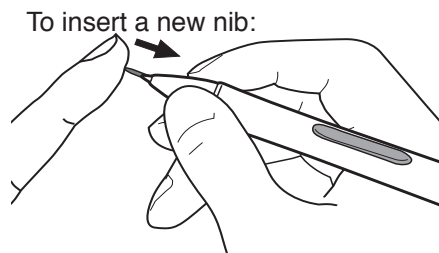

Slide it straight into the barrel of the pen. Firmly push the nib until it stops. The new nib will slide into the correct position.

CAUTION

Prevent your children from swallowing the pen nib or side switch. The pen nib or side switch may accidentally be pulled out if children are biting on them.

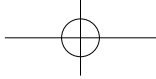

Display Troubleshooting

If you encounter problems with DTU-710 display, refer to the following tables. Your problem may be described here, and you can try the solution offered.

For the problems regarding tablet or pen, refer to the Troubleshooting chapter in the online Help that can be accessed from the Wacom Tablet control panel.

General Problem	Hint
<p>The message "OUT OF SCAN RANGE" appears.</p> <div data-bbox="174 683 519 836" style="border: 1px solid black; padding: 5px;"> <p>i INFORMATION</p> <p>OUT OF SCAN RANGE xx .xkHz / xxHz</p> </div>	<ul style="list-style-type: none"> ■ The input signal frequency is incorrectly set or not compatible with DTU-710. Connect different monitor and set the refresh rate to some value between 50 to 75 Hz. If your video card supports adjustment of the horizontal frequency, make sure it is set to same value between 30 to 80kHz. ■ The resolution is set too high (1280 x 1024 max.) ■ Set the display property to detect plug and play monitors.
<p>■ The message "NO INPUT SIGNAL" appears.</p> <div data-bbox="174 983 519 1136" style="border: 1px solid black; padding: 5px;"> <p>i INFORMATION</p> <p>NO INPUT SIGNAL GO TO POWER SAVE</p> </div>	<ul style="list-style-type: none"> ■ Check the video cable for bent or broken connector pins. Then properly connect the video cable. ■ If your computer is in the power management mode, move the mouse or hit any key on your keyboard. ■ Verify that the graphics card is properly installed.
<p>■ The power lamp is lit orange, or flashes orange and green</p>	
<p>The message "CABLE DISCONNECTED" appears.</p> <div data-bbox="174 1389 519 1542" style="border: 1px solid black; padding: 5px;"> <p>i INFORMATION</p> <p>CABLE DISCONNECTED GO TO POWER SAVE</p> </div>	<ul style="list-style-type: none"> ■ Check that your computer is turned on. ■ Check that the DTU-710 video cable is fully connected. ■ Check the video connector and any video adaptors for bent or broken connector pins. Then properly connect the video cable and necessary adaptors.
<p>■ No display. The LED is off.</p>	<ul style="list-style-type: none"> ■ Verify that the AC power cable is connected, and that the DTU-710 power switch is turned on. ■ Verify that the Analog (VGA)/Digital (DVI) switch is properly set.  P.6 Restart your computer after changing the position of the switch.

When a still image is displayed for a long period of time without refreshing the screen, an afterimage remains for a short period of time. Use a screen saver or other power management feature.

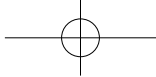

General Problem	Hint
The image appears multiple times on the display.	Do not extend the video cable. Do not use an input selector switch box.
The color white does not display as white.	<ul style="list-style-type: none"> ■ Be sure the DTU-710 color profile has been installed and is selected as the profile for use with your operating system and applications. Verify also that the display is operating at the factory default settings. If that is not sufficient, then adjust color as necessary. For details on color management, refer to your operating system and application documentation. ■ Verify that the video cable and connectors are fully connected.
VGA Problem	Hint
Display ripples or flickers	<ul style="list-style-type: none"> ■ Open the OSD menu, go to the Reset menu, and select the Auto Adjust option. Then, if necessary, manually adjust pitch and phase. P15, 17 ■ Verify that the display adaptor or graphics card matches DTU-710 specifications. ■ Adjust the refresh rate of your computer.
Display is not clear.	<ul style="list-style-type: none"> ■ As necessary, adjust contrast or brightness. P15 ■ As necessary, adjust pitch and phase. P15, 17 ■ Set the display resolution of your video card to 1280 x 1024.
The image appears multiple times on the display.	<ul style="list-style-type: none"> ■ Do not extend the video signal cable. Do not use an input selector.
<ul style="list-style-type: none"> ■ The display and LCD panel are not lined up. 	<ul style="list-style-type: none"> ■ Open the OSD menu, go to the Reset menu, and select the Recall option.
<ul style="list-style-type: none"> ■ Display size is not correct. 	<ul style="list-style-type: none"> ■ Adjust pitch and phase, horizontal and vertical position. P15, 16, 17. Note that some graphics card may not show display in proper size.
<ul style="list-style-type: none"> ■ Display ripples or shows moiré. 	<ul style="list-style-type: none"> ■ Open the OSD menu, go to the Reset menu, and select the Recall option.
<ul style="list-style-type: none"> ■ The display color is not even. 	<ul style="list-style-type: none"> ■ As necessary, adjust pitch and phase. P15, 17



Obtaining Technical Support

If you have a problem with DTU-710, first check the appropriate setup chapter in this guide to make sure the unit is installed correctly. Then review the Troubleshooting section within this manual and the online Help; your problem may be described there and you can try the solution offered. You can also check the product FAQs (Frequently Asked Questions) on the Wacom web site.

Support Staff

If you think your DTU-710 Interactive Pen Display is not working properly, contact the Wacom authorized distributors in your area (Check your area distributor on the Wacom web site: <http://ap.wacom.co.jp>), or contact us as the following:

Asia

Tel: ++81-3-3371-1595 (English)

Fax: ++81-3-3371-1468 (English)

Email: asia-pacific@wacom.co.jp Sales and Support (English)

web site: <http://ap.wacom.co.jp> (English)

People's Republic of China

Tel: ++86-10-8606-1218

Fax: ++86-10-8606-2386

Email: support@wacom.com.cn

Web site: <http://www.wacom.com.cn>



Specifications

General Specifications

Physical dimensions (WxDxH):	418x362x57mm (excluding the stand)
Weight:	5.8kg (including the stand)
Main Unit input Voltage:	DC12V
Power consumption:	45W or less (DC12V)
Operating temp. & humidity:	5 to 35 deg. C, 80%RH (non condensing)
Storage temp. & humidity:	10 to 60deg. C, 90%RH (non condensing) (maximum storage humidity is 38% at 60 deg.C, and maximum storage temperature is 42 deg. C at 90% humidity)

LCD Display

Display:	a-Si TFT active matrix LCD
Screen size:	17 in
Resolution (75Hz Max.)	1280x1024 pixels (SXGA), 1024x768 pixels (XGA), 800x600 pixels (SVGA), 640x480 pixels (VGA)
Pixel pitch:	0.264(W) x 0.264(H)mm
Color depth:	253 levels: 16,190,000 colors (24 bit)
Signal Inputs:	Analog RGB / Digital signals (DVI 1.0) Synchronous frequency: Horizontal 30 to 65kHz, Vertical 50 to 75Hz All scan modes are non-interlaced.
Refresh Rate	50 to 75Hz
Plug and Play	DDC2B

On a TFT liquid crystal display, a very small number of pixels may be permanently illuminated or not illuminated at all. This does not mean that the display is defective.

Tablet

Reading technology:	Electromagnetic resonance method
Active area:	337.9 x 270.3mm
Resolution:	20 lpmm (0.05mm) max.
Accuracy:	+/-0.5mm, four corners (7 mm wide, 25 mm long from each corner of four "L" shaped areas) to be +/-1.0mm
Maximum reading height:	5mm
Maximum report rate:	205 points/sec., max
Pressure levels:	512 levels
Communication interface:	USB or RS-232C serial



Specifications

Power Adaptor

Input voltage: 100 to 240 VAC, 50/60 Hz
Output voltage: 18 VDC, 2.5 A

Pen (UP-911E)

Pen tip travel: 0.1 mm (0.004 in) or less
Eraser tip travel: 2 mm (0.08 in), approximately
Physical dimensions, weight: 14.0 x 159.0 mm, 16g (0.63 x 6.26 in, 0.56 oz)
Side switch type: Rocker switch

Pen Accessories

Extra nib: PSI-A021
Pen holder: PST-A026



RADIO AND TELEVISION INTERFERENCE

The equipment described in this manual generates, uses, and can radiate radio-frequency energy. If it is not installed and used properly – that is, in strict accordance with Wacom instructions – it may cause interference with radio and television reception.

FEDERAL COMMUNICATIONS COMMISSION (FCC) NOTICE

This equipment has been tested and found to comply with the limits for a Class B digital device, pursuant to Part 15 of FCC Rules. These limits are designed to provide reasonable protection against harmful interference in a residential installation.

This equipment generates, uses and can radiate radio frequency energy and, if not installed and used in accordance with the instructions, may cause harmful interference to radio communications. However, there is no guarantee that interference will not occur in a particular installation.

You can determine whether the tablet equipment is causing interference by powering it off. If the interference stops, it was probably caused by the tablet.

If your tablet equipment does cause interference to radio or television reception, you may be able to correct the interference by using one or more of the following measures:

- Rotate the television or radio antenna until the interference stops.
- Move the tablet equipment farther away from the television or radio.
- Plug the tablet equipment and computer into an outlet that is on a different circuit from the television or radio.

If necessary, consult your Wacom dealer or an experienced radio/television technician for help.

Changes or modifications to this product not authorized by Wacom could void the FCC Certification and negate your authority to operate the product.