

# Waves SSL 4000 Collection

## SSL 4000 E-Channel

## SSL 4000 G-Channel



## 1. Introduction

The unique sound of Solid State Logic's 4000 Series analogue mixing consoles is sought after worldwide. Engineers of pop and rock music, broadcast transmissions and television post-production value the SSL 4000's flexible dynamics chain as much as the trademark SSL "punchy" sound. Waves and SSL engineers have worked together for over a year to recreate the sound characteristics of the classic SSL 4000 Series E and Series G consoles. Now, those who "mix in the box" can achieve the sound they thought they'd lost when they moved to the digital world.

The SL4000 console was the first mixing desk to incorporate dynamics processing into every channel, as well as a master bus compressor in the console's center section. The ability to 'patch' into the SL4000's master bus compressor and to control its sidechain from an internal sub-mix allowed sound engineers to discover unique, history-making applications of this console technology. Whether used to record instruments such as piano and drums or for final mixing, these innovative console sections - master bus compressor, EQ and dynamics - opened up a

new world of opportunities. For years, workstation users have sought this unusual flexibility and signature sound. But conventional dynamics and EQ plug-ins couldn't produce the unique SSL color.

The Waves SSL 4000 Collection is the result of a partnership between Waves Audio and Solid State Logic. These processors faithfully recreate the same EQ and dynamics characteristics which made legendary the SL4000 consoles. Plus, the interface accurately reflects the classic SSL console. Couple all of this with state-of-the-art Waves software and you suddenly find yourself working with the same tools that have provided countless hit mixes for the world's best audio engineers.

The Waves SSL 4000 Collection consists of three separate sections:

- The SSL E-Channel/ G-Channel
- The SSL 4000 G-Master Bus Compressor
- The SSL G-Equalizer

## 2. Description of the SSL 4000 E-Channel/ G-Channel plug-in

### SSL E-Channel

The Waves SSL E-Channel is modeled after the SL4000 E Series console, combining the dynamics section of the SL4000 channel strip with the "Black Knob" 242 EQ. The only obvious change from the hardware original is that the EQ and Dynamics sections are side-by-side rather than inline, to better conform to computer screens.

### SSL G-Channel

The Waves SSL G-Channel is modeled after the SL4000 G Series console, combining the dynamics section of the SL4000 channel strip with the 383 G EQ. The only obvious change from the hardware original is that the EQ and Dynamics sections are side-by-side rather than inline, to better conform to computer screens.

### Dynamics Section

The dynamics section consists of a soft-knee compressor/limiter and an expander/gate. Dynamics can be switched to pre-equalizer (*default*) or post-equalizer (**CH OUT**.)

Although the same gain change circuitry is used for both the compressor/limiter and the expander/gate, two dedicated level indicators illustrate activity for each device. Automatic gain make-up, calculated from the *Ratio* and *Threshold* settings, is applied by the compressor to maintain a steady output level. The default compressor attack time is program sensitive, responding to the audio material's wavefront.

The dynamics section's threshold circuitry uses variable hysteresis, which allows the signal to decay below its opening level. (Hysteresis is the lag between making a change in input, such as increasing or decreasing power, and the response or effect of that change. Thus, the threshold's variable hysteresis circuitry allows for program-dependent dynamic processing.)

### Equalizer Section

The equalizer is a four-band device which can be routed to the processor's output or to the dynamics section's sidechain. Q can be adjusted in the LMF and HMF ranges. At the top of the

section is the **High Pass** (18 dB/octave) filter and the **Low Pass** (12 dB/octave) filter. Normally, low pass and high pass filters follow the same path as the entire EQ section. However, when *SPLIT* is selected, the low pass and high pass filters are placed before the dynamics processors in the chain. The equalizer can be switched into the dynamics sidechain to afford simple de-essing and other frequency-controlled dynamics processing by selecting **DYN S-C** at the foot of the section. In the E-Channel LF and HF shelves can be reshaped to bell curves by pressing **BELL**. The Q of the LF and HF bells are calculated based on frequency settings and are not user-definable. In the G-Channel Lf and HF are fixed shelves, the LMF /3 will divide the LMF frequency by 3, and the HMFx3 will Multiply the HMF frequency by three.

### SSL Channel Latency

The channel strip has a latency of one sample.

### Routing in SSL Channel

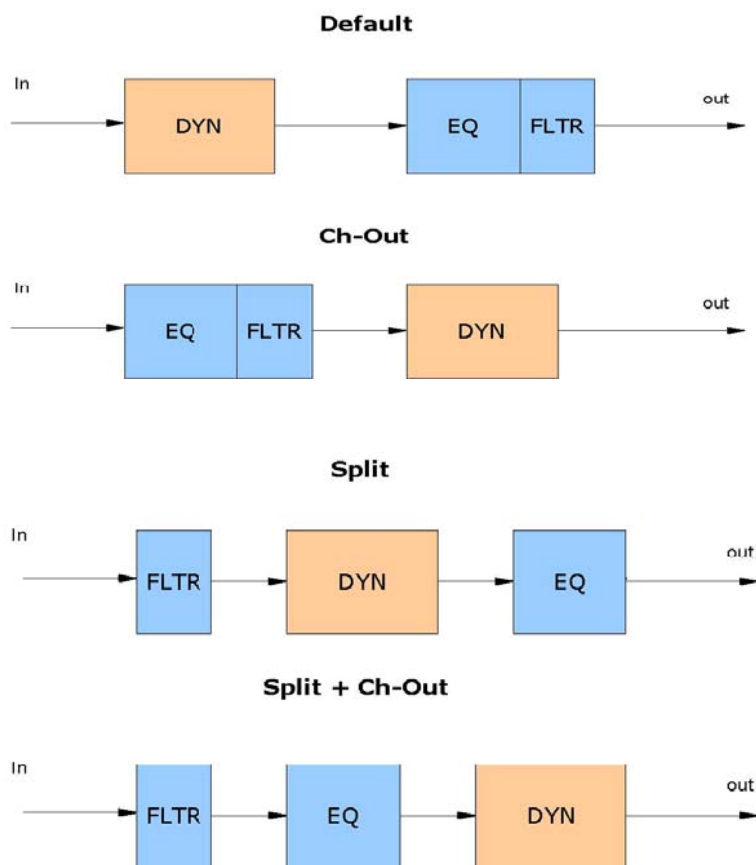

### Side Ch.

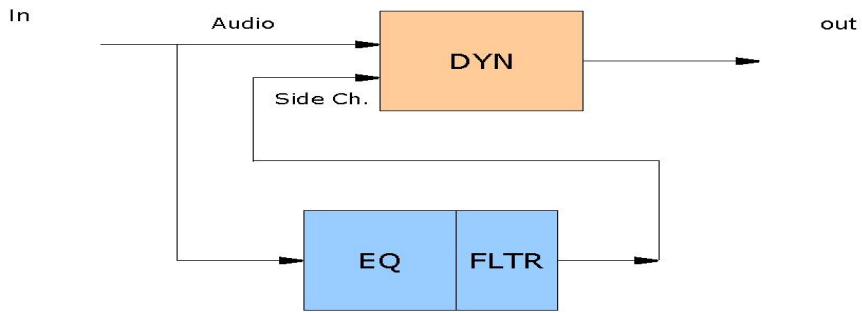

### Split + Side Ch.

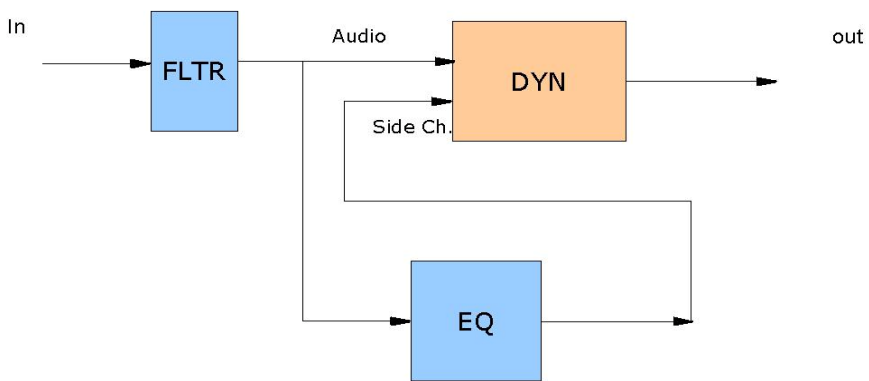

## 3. SSL 4000 Channel Controls and Indicators



## Dynamics Sections Controls (top to bottom)

### 1. Compressor (white knobs)

- The compressor's *Ratio/Slope* can be set from 1 to infinity (limiter).
- The *Threshold* is variably adjustable from +10 dB to -20 dB.
- When the *Attack* time switch is set to *Slow* (**F.ATK** off,) attack time is auto-sensing and program dependent. In the *Fast* setting (**F.ATK**), attack time will be forced to 1 ms.
- Release time is adjustable from 0.1 sec to 4 seconds.

### 2. Expander/Gate (green knobs)

- The expander's *Threshold* is variable from -30 dB to +10 dB
- Range* is variable from 0 – 40 dB.
- When the *Attack* time switch is set to *Slow* (**F.ATK** off,) attack time is auto-sensing and program dependent. In the *Fast* setting (**F.ATK**), attack time is 1 ms.
- Release* time is adjustable from 0.1 sec to 4 seconds.
- The **GATE** switch toggles the section from an expander (default mode) into a gate.

### 3. Dynamics to (DYN TO) switches

- a. **BYPASS** will bypass the entire dynamics section. Note that selecting **BYPASS** does not result in a signal which is flat, but rather one which mimics the flat response of the SSL channel strip hardware.
- b. **CH OUT** moves the dynamics to the output of the E-Channel, making it post-EQ.

### SSL E EQ Section Controls (top to bottom)

1. **Low and High Pass filters** (white knobs):  
Low pass: 18 dB/octave, 15 Hz – 350 Hz (-3 dB point)  
High pass: 12 dB/octave, 3 kHz – 20 kHz (-3 dB point)  
Turning the knob completely to the left bypasses the filter.  
When *SPLIT* is selected, the low pass and high pass filters are placed before the dynamics processors in the chain.
2. **High frequency EQ section** (red knobs): Range 1.5 kHz – 16 kHz. Gain range is  $\pm 18$  dB for bell shape,  $\pm 16.5$  dB for shelving. Selecting **BELL** changes the HF EQ from shelf to bell shape.
3. **High medium frequency EQ section** (green knobs): Range 600 Hz – 7 kHz. As in the LMF EQ section, Q is continuously adjustable from 0.1 to 3.5. Gain varies from  $\pm 18$  dB when Q is set at 3.5 to  $\pm 15$  dB when Q is set at 0.1.
4. **Low medium frequency EQ section** (blue knobs): Range 200 Hz – 2.5 kHz. Q is continuously adjustable from 0.1 to 3.5. Gain varies from  $\pm 18$  dB when Q is set at 3.5 to  $\pm 15$  dB when Q is set at 0.1.
5. **Low frequency EQ section** (black knobs): Range 30 Hz – 450 Hz. Gain range  $\pm 16.5$  dB, shelving,  $\pm 18$  dB, bell shape.

### SSL G EQ Section Controls (top to bottom)

1. **Low and High Pass filters** (white knobs):  
Low pass: 18 dB/octave, 15 Hz – 350 Hz (-3 dB point)  
High pass: 12 dB/octave, 3 kHz – 20 kHz (-3 dB point)  
Turning the knob completely to the left bypasses the filter.  
When *SPLIT* is selected, the low pass and high pass filters are placed before the dynamics processors in the chain.
2. **High frequency EQ section** (red knobs): Range 1.5 kHz – 16 kHz. Gain range is  $\pm 17$  dB shelving.
3. **High medium frequency EQ section** (green knobs): Range 600 Hz – 7 kHz. As in the LMF EQ section, Q is continuously adjustable from 0.1 to 3.5. Gain varies from  $\pm 18$  dB when Q is set at 3.5 to  $\pm 15$  dB when Q is set at 0.1. Pushing the HMF X3 will multiply the frequency by 3.
4. **Low medium frequency EQ section** (blue knobs): Range 200 Hz – 2.5 kHz. Q is continuously adjustable from 0.1 to 3.5. Gain varies from  $\pm 18$  dB when Q is set at 3.5 to  $\pm 15$  dB when Q is set at 0.1. Pushing the LMF /3 will divide the frequency by 3.
5. **Low frequency EQ section** (black knobs): Range 30 Hz – 450 Hz. Gain range  $\pm 17$  dB, shelving.

### 6. EQ TO switches

- a. **BYPASS** This button bypasses the EQ section. Note that selecting **BYPASS** does not result in a signal which is flat, but rather one which mimics the flat response of the SSL channel strip hardware.
- b. **DYN S-C** The filters can be switched into the dynamics sidechain to afford simple de-essing, etc. by selecting **DYN S-C**.

## Master Section Controls and Indicators

On the bottom right of the SSL Channel Strip are the master gain controls and level indicator.

1. **Level Indicator** Levels are expressed in dBFS, although all parameters are expressed as dBu.
2. **INPUT** and **OUTPUT** switches above the meter allow you to toggle the level indicator between input and output.
3. An **Input Trim Button** enables you to trim the input to the channel by  $\pm 18$ db. The plug-in is aligned so that  $-18$  dBFS = 0.
4. The **Output Fader** controls the output level of the processor.
5. **Analogue on/off**. Classic analogue processors necessarily create more noise and harmonic distortions than modern digital devices. This is, in part, what gives analogue processors their desired sound. By default, all components of the SSL 4000 Collection operate in a mode which enables emulation of the SSL analogue console. However, there may be times when you prefer to use this plug-in without these special attributes. Switching off *Analogue* disables analogue emulation.
6. **Phase Reverse (Ø)** This button reverses the phase of the input signal.

## 4. The Waves System Bar

All Waves plug-ins share a common feature, the Waves System Bar, which takes care of most administrative functions you will encounter while working with Waves plug-ins. Since the Waves System Bar is the same on practically all Waves plug-ins, you will always know how to file, compare, load and copy the parameters of a Waves plug-in, even if you have never before worked with that particular processor.

### Commands common to all Waves plug-ins:

**Undo** undoes the last performed action.

**Redo** redoes the last undone action. There are 6 levels of undo and redo.

**Setup A/B** toggles between two sets of parameters within the same processor – useful when comparing different parameter settings in order to achieve optimal results.

**Copy A->B** copies the current settings to the second setup register.

**Save** used for saving presets in the Waves file format (.xps)

There are two options for saving:

**Save to new file:** creates a new .xps file wherein multiple presets can be saved.

**Save into preset menu:** saves the preset into the default list of the plug-in.

**Load** allows recalling presets from files.

Once a file is selected, its first preset will load and become active. Other presets in the file will be listed under the preset's name in the **Load** menu.

You can also load factory presets and user presets (saved using "**Save into preset menu.**")

Pressing the **?** button will open the manual for the plug-in you are using.