



Excellence in Compliance Testing

FCC Part 15.249 Transmitter Certification

Test Report

FCC ID: KJ8-0001142

FCC Rule Part: 15.249

ACS Report Number: 07-0047 - 15C

Manufacturer: Wayne-Dalton Corporation
Model(s): 3220C-Z, 3222C-Z, 3224C-Z,
3320B-Z, 3322B-Z, 3324B-Z, 3221C-Z

User's Manual



Chain/ Belt Drive

Models: 3220C, 3221C, 3222C, 3224C, 3320B, 3322B, 3324B

3220C-Z, 3221C-Z, 3222C-Z, 3224C-Z, 3320B-Z, 3322B-Z, 3324B-Z

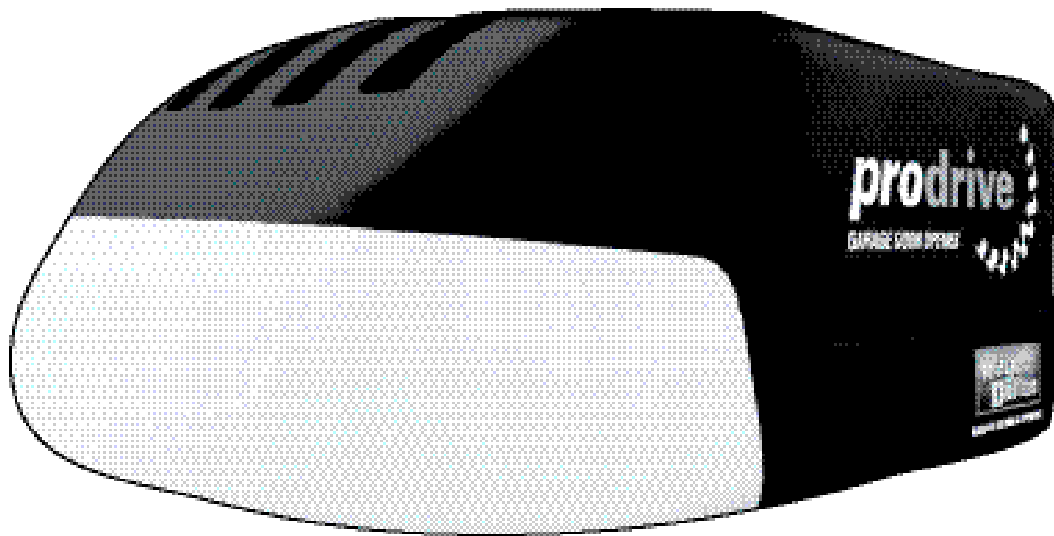

FOR RESIDENTIAL SECTIONAL OVERHEAD GARAGE DOORS ONLY!

DO NOT USE ON ONE PIECE DOORS!

**IMPORTANT! THE DOOR AND OPENER WILL NOT FUNCTION PROPERLY UNTIL
INFRARED SAFETY SENSORS ARE INSTALLED AND PROPERLY ADJUSTED!**

IMPORTANT NOTICE!

Read the enclosed instructions carefully before installing/operating this garage door opener. Pay close attention to all warnings and notes. This manual **MUST** be attached to the wall in close proximity to the garage door.



Package Contents

NOTE: Depending on the opener model, some parts listed may not be supplied.

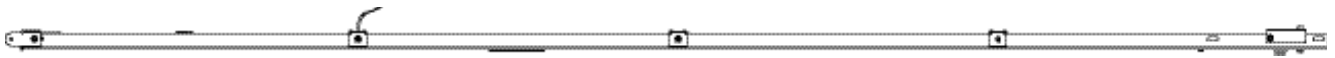

Rail Assembly W/Upper Door Arm



Door Arm Lower

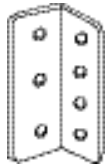

Door Bracket

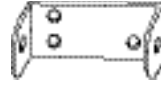

Wall Mounting Brackets

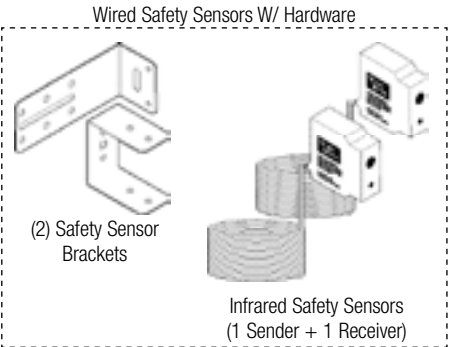

Wired Safety Sensors W/ Hardware

(2) Safety Sensor Brackets



Infrared Safety Sensors (1 Sender + 1 Receiver)



Owner's Manual



Bell Wire



Red Emergency Release Knob



Keychain/Visor Transmitter (1 or 2)

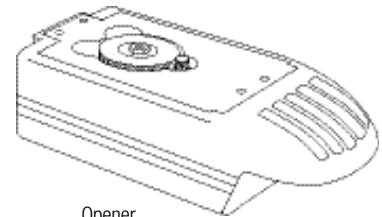

Opener

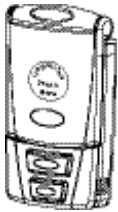

Multifunction Wall Station W/Hardware



Wired Deluxe Wall Station W/Hardware



5 Button Wireless Keyless Entry W/ Hardware



Entrapment Label



Light Diffuser



5/16" x 1-1/4" Multi Grip Clevis Pin



Nylon Shoulder Bushing



Hairpin Cotter



Emergency Release Tag

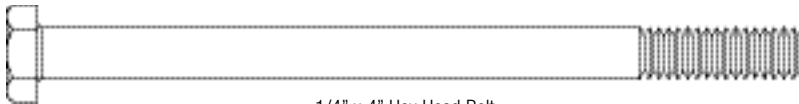

1/4" x 4" Hex Head Bolt

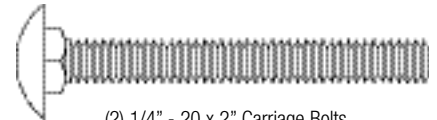

(2) 1/4" - 20 x 2" Carriage Bolts

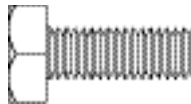

(2) 1/4"-20 x 3/4" Machine Bolts



(2) 1/4" Nylock Nuts



1/4" Plastic Insert Locking Nut

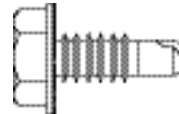

(2) 1/4" - 20 x 5/8" Self Drilling Screws



(2) 1/4" Locking Nuts

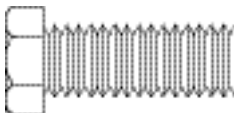

3/8"-16 x 1" Machine Bolt



3/8" Plastic Insert Locking Nut



3/8" Flat Washer

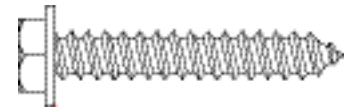

(2) 1/4" x 1-1/2" Lag Screws

Please Do Not Return This Product To The Store. Call Us Directly! Our Trained Technicians Will Answer Your Questions and/or Ship Any Parts You May Need. You can reach us Toll Free at **1-888-827-3667** for Consumer Assistance or online at **www.wayne-dalton.com**

PRE-INSTALLATION INSPECTION OF YOUR GARAGE DOOR PRIOR TO PRODRIVE™ OPENER INSTALLATION

To ensure your new Prodrive™ opener works as intended, your garage door must be properly installed and balanced.

Before installing your garage door opener, open and close your door manually to ensure it operates smoothly from top to bottom. A properly balanced door should not take a lot of effort to open or close by hand. The door should stay in the open and in the closed position without drifting down or creeping up. If a door opens fast, the door may need spring tension reduced. If the door drops fast, the door may need spring tension increased.

If the door operates properly, then proceed to your Prodrive™ installation manual for instructions on how to install the Prodrive™ garage door opener.

If the operation of the door does not meet these requirements, adjust the spring balance per your door's installation manual or call a professional installer to make adjustments before installing Prodrive™.

Instruction manuals are available for download on www.wayne-dalton.com. Use the web site to also find the location of your nearest professional dealer.

Once the door is properly balanced and operates smoothly, you may proceed with the installation of your Prodrive™ garage door opener.

Pre-Installation

IMPORTANT! Before starting the installation read these instructions thoroughly to familiarize yourself with all aspects of installation and adjustment.

IMPORTANT: IF YOUR GARAGE HAS NO SERVICE ENTRANCE DOOR, INSTALL AN OPTIONAL OUTSIDE QUICK RELEASE LOCK. THIS ACCESSORY ALLOWS MANUAL OPERATION OF GARAGE DOOR FROM OUTSIDE IN CASE OF POWER FAILURE.

IDENTIFY YOUR DOOR

Identify your door by referring to illustrations below and verify that your door type is a sectional door with curved track. Do not install if the door is any type of one piece door.

NOTE: The opener has been designed for sectional doors. Do not attempt to install this opener on any style one piece door. Using this opener on a one-piece door may result in serious personal injury or property damage.

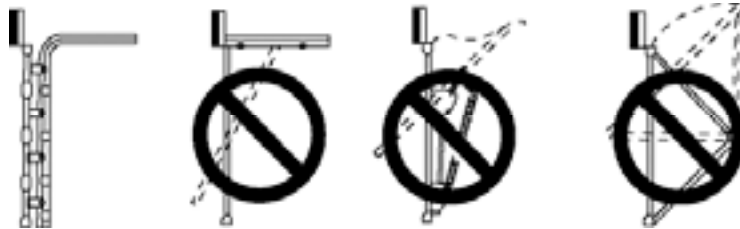

TEST YOUR DOOR

Before you begin, complete the following two tests to insure that the door is balanced and working properly. A door that binds, sticks or is out of balance could cause severe injury. Do not attempt to compensate for an improperly adjusted door by the installation of an opener. This will interfere with the proper operation of the opener's safety features and/or may damage the door or opener. Have a qualified service person make any needed adjustments or repairs before proceeding with installation.

Door Test One

Raise and lower the door and check closely for any sticking or binding that may occur. Lift the door approximately half way open, as illustrated. When releasing the door, it should stay in position. If spring tension pulls the door further open or door weight pulls it down, your door is not properly adjusted.



Door Test Two

When properly installed, a door should remain clear of the opening, when allowed to rest at its natural, full open position. If "door drift" pulls door back into opening or spring tension is not sufficient to pull door totally clear of opening, the door is not properly adjusted.

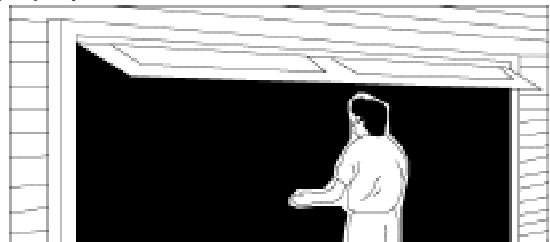

PRE-ASSEMBLY CHECK

Every opener is factory tested and shipped with the limit switch adjustment in the door CLOSED position. If the opener has been powered up before assembly, perform the following steps to insure that the limit switch adjustment is in the door CLOSED position. Connect the opener to a power source and short across the screw terminals labeled "PB" and "COM" with a metal screw driver. Motor should start; run through a full OPEN cycle, (driven gear rotates clockwise) and stop. This will leave opener in OPEN position. To get the opener back to full CLOSE position, short and hold "PB" and "COM" terminals again (driven gear rotates counter clockwise). Continue to short terminals until opener stops in the CLOSED position. If the contact between "PB" and "COM" is lost, the motor will stop, reverse, and travel back to the open limit, repeat with a constant short across "PB" and "COM".

CAUTION: KEEP CLEAR OF ALL ROTATING AND MOVING PARTS.

WARNING

FAILURE TO KEEP CLEAR OF ROTATING AND MOVING PARTS CAN RESULT IN SEVERE INJURY.

Disconnect from power source and proceed to assembly.

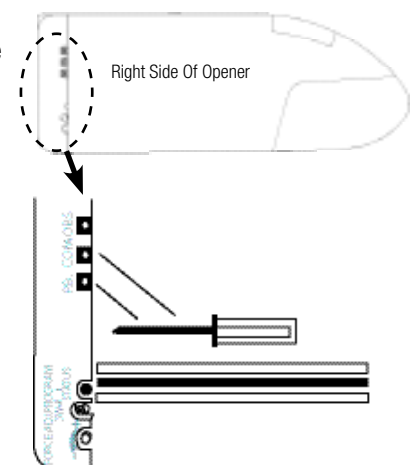

System Features

1. Open and Close Cycle Control:

Allows garage door to be started and stopped by push button, transmitter or wall station. The next impulse sends a stopped garage door in opposite direction.

2. Emergency Disconnect:

Manual disconnect permitting operation of door during power failure with automatic reconnect when opener is reactivated. See page 27.

3. Opener light:

Automatically turns on when opener is activated and remains on for four minutes for convenience and safety.

4. Mechanical Door Lock:

When properly adjusted, opener locks door in closed position preventing unwanted entry. See Adjustment # 3 on page 32.

5. Obstruction Warning Light:

The convenience light will flash after sensing an obstruction in the down direction and/or if the safety system malfunctions while in the open position.

6. Motor:

Permanently lubricated, thermally protected, heavy duty motor with automatic reset.

7. Safety System:

Independent up and down force adjustments. When properly adjusted, the safety system will automatically reverse when obstructed in down direction and return to fully open position. The door will stop when obstructed in the up direction. See Adjustment #2 on page 32.

8. Infrared Safety Sensors:

Wired infrared reversing sensors detect an obstruction in door path and react by reversing door.

9. Multi-Function Wall Station:

Wired wall station provides up/down door motion control and independent overhead light on/off control. Wireless multi-function wall station provides up/down door motion control, independent overhead light on/off control, door down delay, adjustable "pet position" function, and "pet position" program button.

10. Homelink® Compatibility:

Opener is capable of "learning" automobile equipped Homelink® transceivers. Visit: www.homelink.com.

11. Rolling Code Technology:

Wireless transmitters, multi-function wall stations and wireless keyless entry use rolling code which prevent would be thieves from "grabbing" the transmitter's digital code.

Tools Needed



Power Drill



Ratchet Wrench



Needle Nose Pliers



Pliers/Wire Cutters



5/64", 3/32", 1/8", 3/16"
Drill Bits



Hacksaw

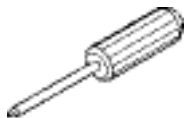

Phillips Head
Screwdriver



1/4", 3/8", 7/16",
1/2", 9/16" Sockets



Pencil



7/16" Wrench



Pliers

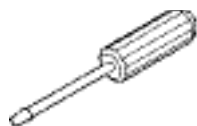

Flat Tip
Screwdriver



7/16" Socket Driver



Level

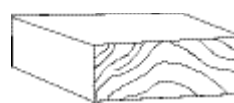

2 x 4 Board



Hammer

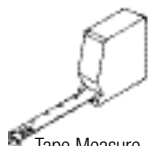

Tape Measure



Safety Glasses

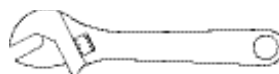

Adjustable Wrench



2 x 6 x 12 Solid Test
Object



Non-Metallic
Step Ladder

Table of Contents

Package Contents	I.
Pre-Installation Inspection	II, III
Tools Needed	IV.
Important Safety Instructions	V.
Prodrive™ Installation	1-5.
Pre-Operation	6-19.
Optional Installations	20-26.
Operation	27-32.
Programing Wireless Wall Station(s) Or Transmitter(s) to Opener ...	33.
Maintenance	34.
Troubleshooting	35.
Parts Breakdown Rail Assembly	36.
Parts Breakdown Opener Assembly	37.
Accessories	38.
Templates	39.
Customer Service Number	40.
Warranty	41.

Definition of key words used in this manual:

WARNING

INDICATES A POTENTIALLY HAZARDOUS SITUATION WHICH, IF NOT AVOIDED, COULD RESULT IN SEVERE OR FATAL INJURY.

CAUTION: PROPERTY DAMAGE OR INJURY CAN RESULT FROM FAILURE TO FOLLOW INSTRUCTIONS.

IMPORTANT: REQUIRED STEP FOR SAFE AND PROPER OPENER OPERATION.

NOTE: Information assuring proper installation of the opener.

WARNING

INCORRECT INSTALLATION CAN LEAD TO SEVERE OR FATAL INJURY. FOLLOW THESE INSTRUCTIONS CAREFULLY.

IMPORTANT INSTALLATION INSTRUCTIONS

- 1. READ AND FOLLOW ALL INSTALLATION INSTRUCTIONS.**
2. Do not connect the opener to electrical power until instructed to do so.
3. Install the entrapment warning label next to the wall station in a prominent location. Install the emergency disconnect label on the emergency disconnect cord.
4. Remove all ropes and remove, or make inoperative in the unlocked position, all locks connected to the garage door before installing the opener.
5. Do not wear rings, watches or loose clothing when installing or servicing a garage door system.
6. It is important that you install all the components supplied with the Prodrive™ opener, i.e., wall stations, safety sensors, etc. Use of parts not supplied by Wayne-Dalton Corp. may cause the opener to malfunction and create unsafe conditions.
7. Wear protective eye wear when installing or servicing the opener or door.
8. Install opener on a properly balanced and operating garage door. Have a qualified service person make adjustments/repairs to cables, spring assemblies, and other hardware before installing the opener. An improperly balanced door could cause severe or fatal injury.
9. Where possible, install the opener seven feet or more above the floor. Mount the emergency disconnect six feet above the floor.
10. Locate the wall station: (a) within sight of door, (b) at a minimum height of five feet, so small children cannot reach it, and (c) away from all moving parts of the door.
11. After installing the opener, the door must reverse when it contacts a 1-1/2" high object (or 2 x 4 board laid flat) on the floor.
12. Installation and wiring must comply with local building and electrical codes. Connect the power cord to a properly grounded outlet. Do not remove the ground pin from power cord.
13. To reduce the risk of injury to persons, use this opener only with sectional overhead doors.
14. Top section of garage door may need to be reinforced before attaching opener. Check with your garage door manufacturer for their recommendations.
15. Do not use sensitivity adjustments to compensate for a poorly operating door. This will prevent proper operation of the safety reverse feature and may damage the door and cause possible severe or fatal injury.
16. Open door must not close and closing door must reverse and open if infrared safety sensors are obstructed by 6" high object placed on garage floor.
17. Use a sturdy, non-metallic step ladder when installing opener.

AFTER INSTALLATION IS COMPLETE, FASTEN THIS MANUAL NEAR GARAGE DOOR. PERFORM OBSTRUCTION TESTS MONTHLY AND MAINTENANCE AS RECOMMENDED. SEE PAGES 17 & 34.

1

Attaching Opener to Rail

Tools Needed:

3/8" Socket

Ratchet Wrench

IMPORTANT: THE DRIVER GEAR IN THE OPENER MUST BE PROPERLY ALIGNED WITH THE SPROCKET/ COUPLING COGS IN THE RAIL ASSEMBLY AND THE MOUNTING BOLTS FULLY TIGHTENED, BEFORE POWERING UP THE OPENER. NEGLECTING TO DO THIS WILL RESULT IN GEAR FAILURE.

Before assembly, align sprocket/ coupling cogs to match notches of driver gear. Rotate the motor spline to position driver gear so the nearest notch in driver gear is directly behind motor spline, as illustrated.

NOTE: Do not rotate more than 1/2 turn.

Place opposite end of rail on temporary support approximately 6" in height.

Proceed with attaching rail to opener, ensuring proper engagement between sprocket/coupling cogs and driver gear notches. Realign if necessary, making sure to keep any rotation only to the nearest notch. Using the (4) pre-attached 1/4"-20 x 5/8" hex head bolts, assemble rail to opener using 3/8" socket; tighten securely.

NOTE: Do not plug the opener power cord into electrical outlet until opener is fully installed and you are instructed to do so in this manual.

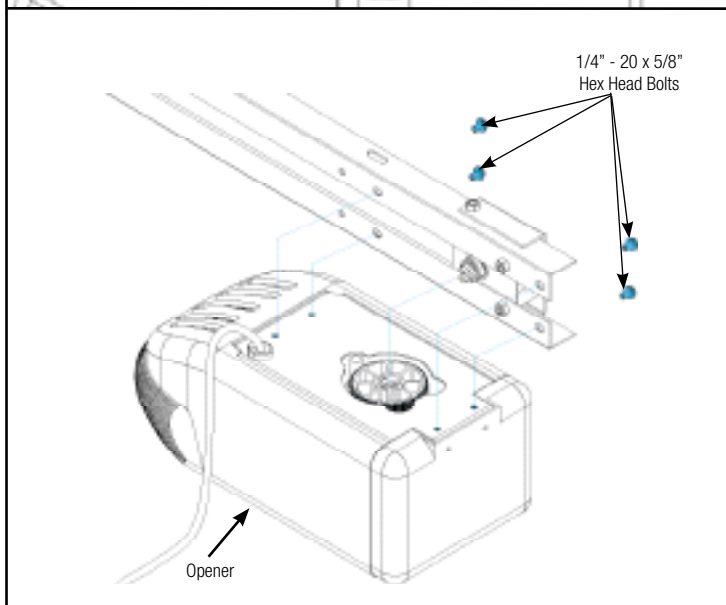
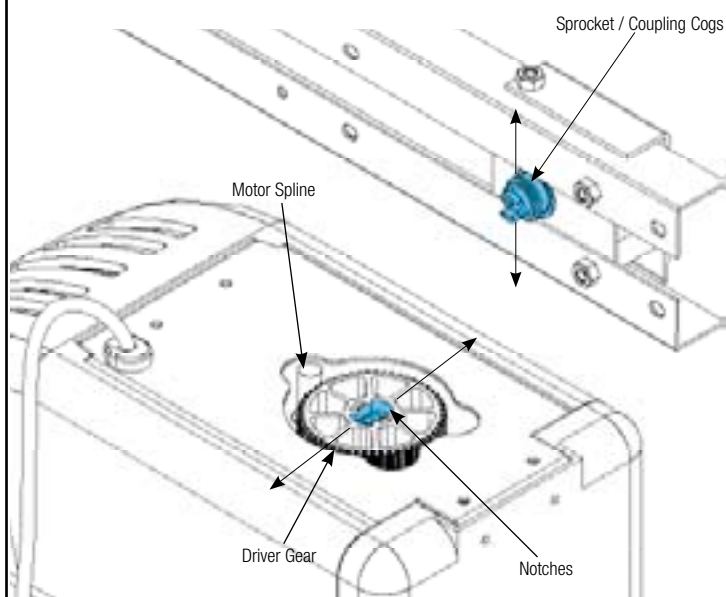
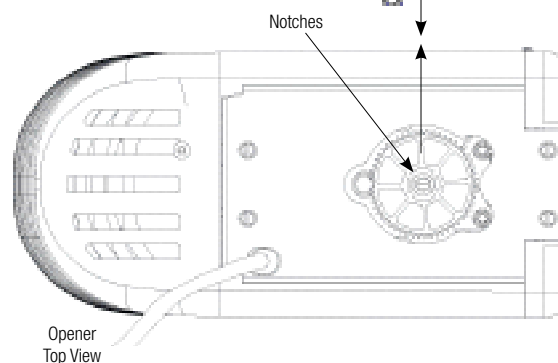
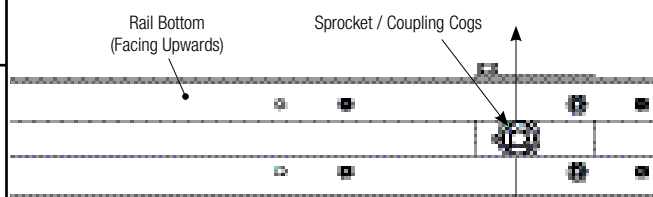

2

Positioning and Installing Front Wall Bracket

Tools Needed:

Carpenter's Level

7/16" Socket Driver

Power Drill

Tape Measure

1/8" Drill Bit

NOTE: It is recommended that the door opener be installed 7 feet or more above the garage floor.

REINFORCE THE HEADER WALL

Reinforce the header wall (wall above door opening) as required, to ensure rigid mounting of the front wall bracket.

WARNING

DO NOT ATTEMPT TO LOOSEN OR REMOVE ANY PORTION OF DOOR SPRING SYSTEM IN ORDER TO REINFORCE HEADER WALL OR TO MOUNT WALL BRACKET. SPRING SYSTEM IS UNDER EXTREME TENSION AND CAN CAUSE SEVERE OR FATAL INJURY. SUCH WORK SHOULD BE DONE BY A QUALIFIED SERVICE PERSON.

Locate the vertical center line of the garage door and mark it on the header above the door.

Raise the door slightly until the top section reaches the highest point of travel (High Arc Point); using a carpenter's level, transfer and mark the highest point of travel onto the header wall and close the door.

Mount the front wall bracket with its lower edge approximately 1/2" - 1" above the mark showing the highest point of travel and centered on the vertical center line.

NOTE: For low headroom torsion counterbalance, hold the wall bracket's bottom edge typically at 1/2" - 1" (room permitting) above the torsion spring center bracket and centered on the vertical line, see illustration.

Mark the two mounting holes and pilot drill with a 1/8" drill bit. Mount wall bracket using the 1/4" x 1-1/2" lag screws supplied to ensure rigid mounting.

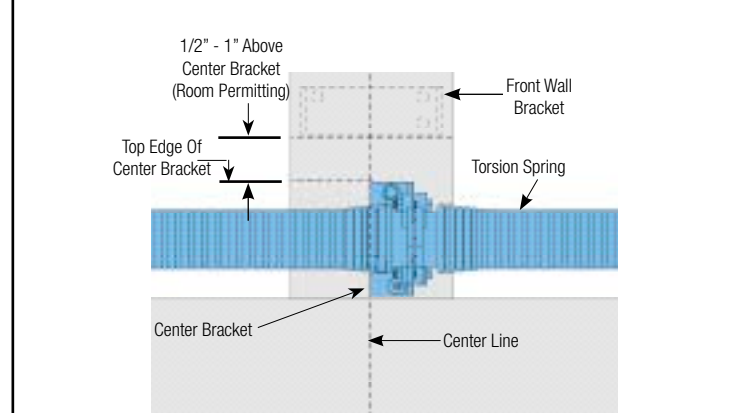
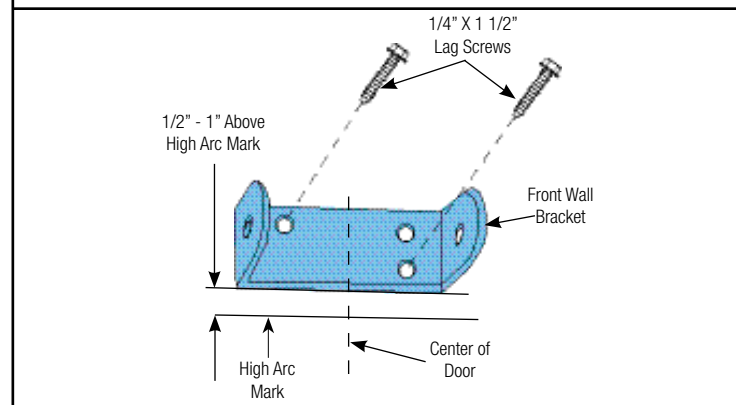
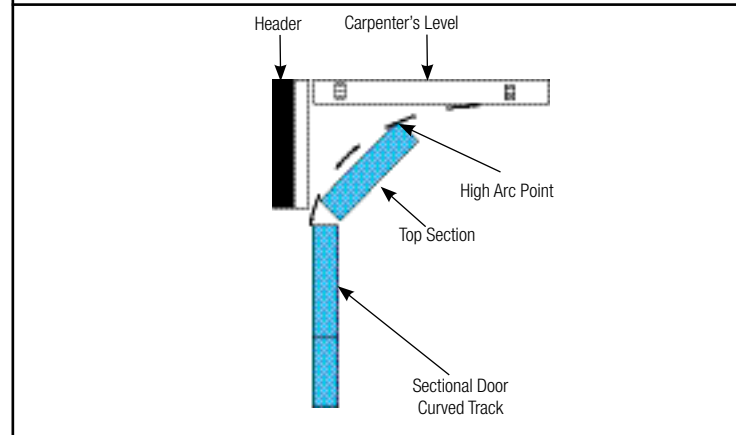
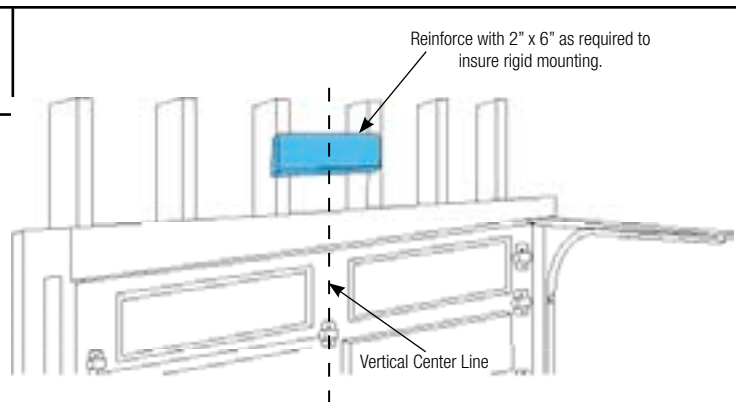

3

Attach Unit to Front Wall Bracket

Tools Needed:

7/16" Socket

Ratchet Wrench

Adjustable Wrench

Raise the front end of the rail assembly and attach it to the front wall bracket, using the 1/4" x 4" hex head bolt and the supplied 1/4" plastic insert locking nut. Take care not to over tighten nut. Tighten only until end of bolt is flush with outside of nut.

NOTE: If you have a torsion spring counterbalance system, it will be necessary to raise the opener and support it on a step ladder to attach the front end of the rail assembly to the wall bracket.

The upper door arm is secured to the spacer bracket with one tie wrap for shipping. Remove tie wrap attaching upper door arm to the spacer bracket, allowing door arm to swing down (see caution).

CAUTION: Support upper door arm with your free hand, to prevent door arm from swinging down uncontrolled.

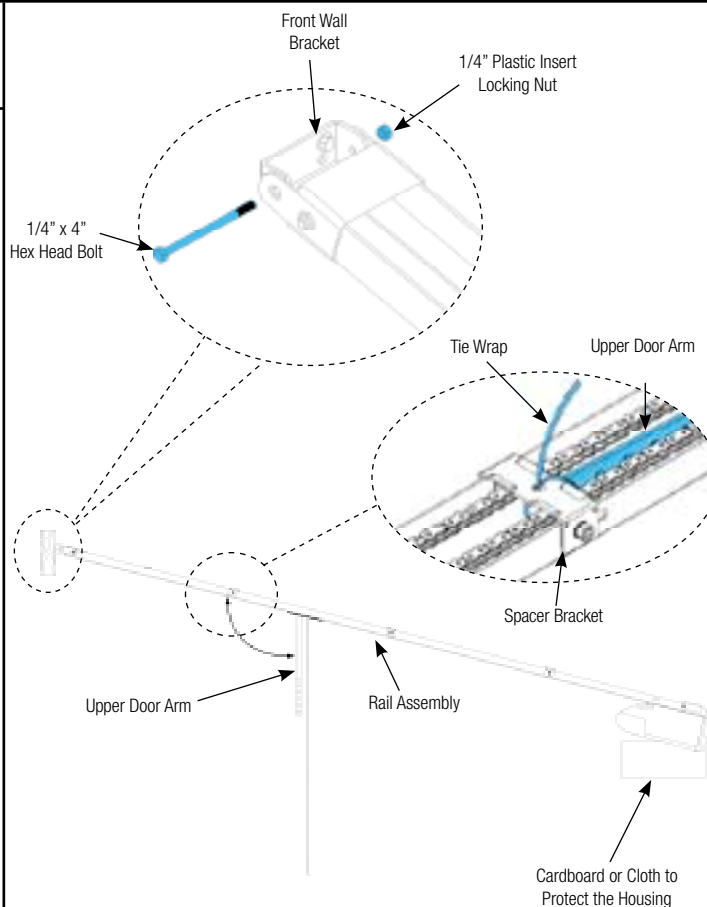

4

Positioning Motor End of Opener

Tools Needed:

2" x 4" Board

Non-Metallic Step Ladder

IMPORTANT: TO PREVENT DAMAGE TO DOOR, DO NOT REST THE OPENER ON THE DOOR WITHOUT USING A 2" X 4" BOARD AT LEAST 3 FEET LONG.

Raise the motor end of the opener and support it so you can open the door to its fully open position. You may need help raising motor end if ladder is not high enough.

IMPORTANT: TO PREVENT DAMAGE TO DOOR OR OPENER, POSITION TROLLEY AS CLOSE TO OPENER AS POSSIBLE, BEFORE OPENING DOOR.

Open the door and place a 2" x 4" x 36" minimum board along the top section of the garage door. Rest the rail assembly on the 2" x 4" board.

Support top section of door to prevent excessive sagging.

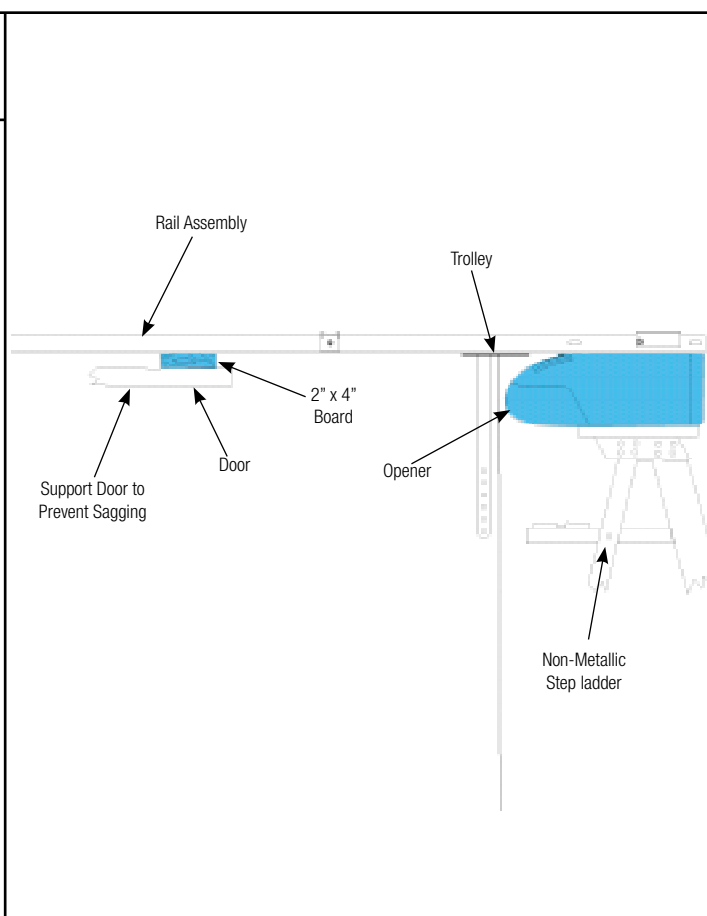

5

Mounting Opener End

Tools Needed:

Power Drill

Hacksaw

1/8" Drill Bit

1/2" Socket

7/16" Socket

Ratchet Wrench

Adjustable Wrench

Tape Measure

Perforated Angle
Iron (Not Supplied)

CAUTION: Do not use gear cap bolt or nut for hanger attachment. This may cause sprocket, chain or Belt misalignment, resulting in damage to opener or possible personal injury!

Align the center of opener's rail assembly with the center line previously marked on the top section of the garage door to ensure rail will be parallel with the direction of door travel.

Using perforated angles (cut to proper length) hang opener end from ceiling joist. Be sure to locate and mount to ceiling joists, as illustrated.

Pilot drill with 1/8" drill bit and use 1/4" x 1-1/2" lag screws (not supplied) to ensure a rigid mount. Attach opener to perforated angles using 5/16" x 3/4" bolts and 5/16" lock washer; nuts (not supplied).

NOTE: Bracing should be at an angle to provide rigid support.

When opener is securely attached to perforated angles, remove the 2" x 4" (used to support rail assembly in Step 4) and close the door.

NOTE: It is recommended that 10' rails be supported in the center to prevent sagging.

Opener rail should be aligned perpendicular to the garage door when properly installed. There should be no sagging of the rail in any direction.

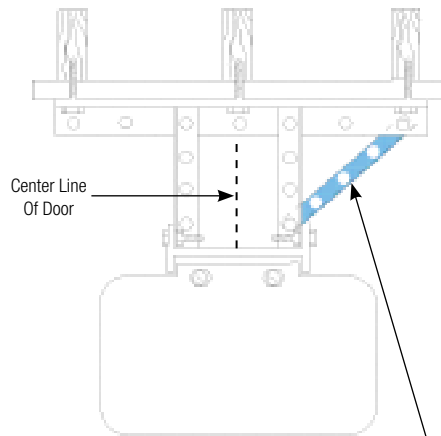
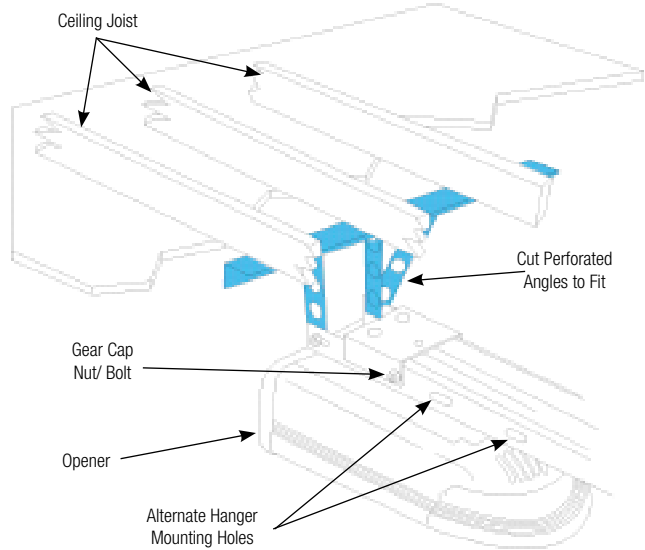

Use angled brace to ensure rigid installation.

PROPER INSTALLATION

Top view

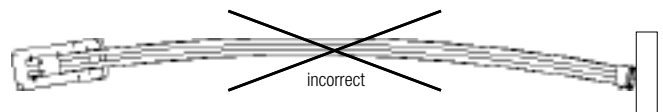
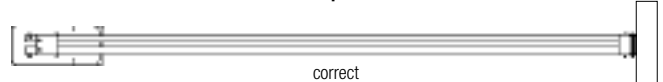

Side view

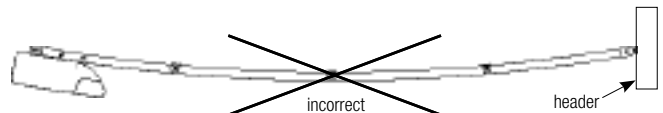
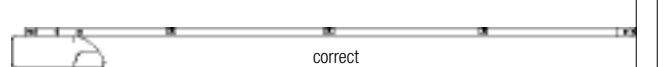

6

Mounting Door Bracket

Tools Needed:
7/16" Socket
Ratchet Wrench

NOTE: If you have a 5120, 5140, 9100, 9400, 9600, 9700 or 9800 series door, do not install this door bracket, install the door bracket supplied with the door, see the Installation Instructions and Owner's Manual supplied with the door. Instructions manuals are available for download at www.wayne-dalton.com or call 1-888-827-3667.

IMPORTANT: DOORS MAY NEED TO BE REINFORCED TO PREVENT DAMAGE TO THE DOOR. CHECK WITH THE GARAGE DOOR MANUFACTURER FOR PROPER REINFORCING OF YOUR DOOR.

For wood doors, mount door bracket, using two 1/4"-20 x 2" carriage bolts and 1/4" locking nuts supplied, on center line of door with middle hole in line with top rollers.

For metal doors, mount door bracket, using two 1/4"-20 x 5/8" self drilling screws supplied, on center line of door with middle hole in line with top rollers.

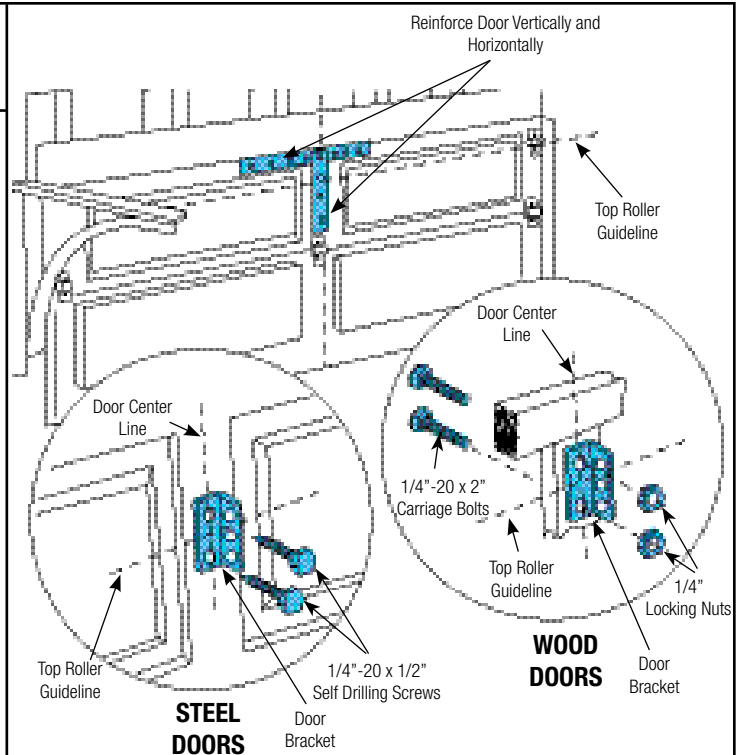

7

Installing Light

Tools Needed:
None

Remove lens by pressing up on both sides of the bottom of the lens at the junction of the housing, releasing the locking tabs, and pulling forward.

Screw a 60 watt (Maximum) bulb into socket. For maximum bulb life, "rough service" bulbs are recommended.

Align the top and bottom tabs on the lens with the housing and push straight on until lens locks in place.

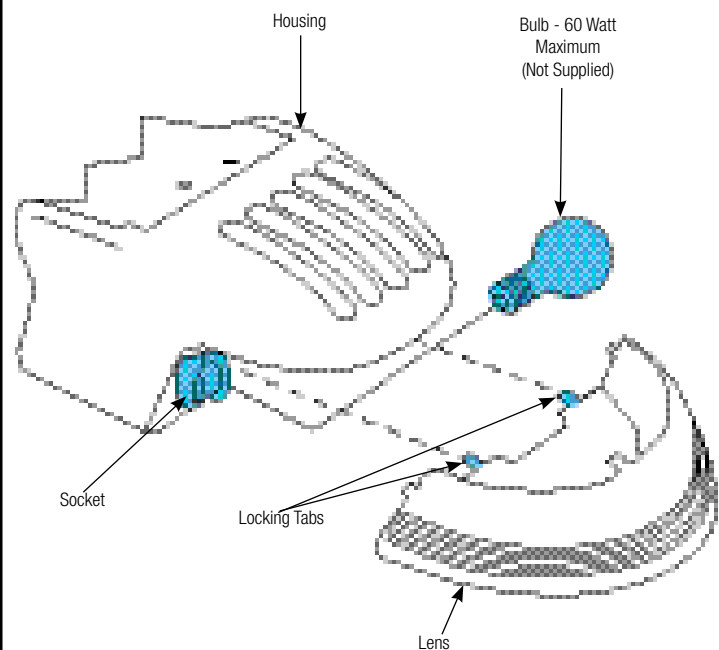

8

Wired Wall Station Installation (If Included)

Tools Needed:

Power Drill

Phillips Head
Screwdriver

Flat Tip
Screwdriver

3/32" Drill Bit

WARNING

TO PREVENT POSSIBLE INJURY, INSTALL WALL STATION OUT OF THE REACH OF CHILDREN AND IN A LOCATION WHERE THE DOOR CAN BE SEEN WHEN THE OPENER IS ACTIVATED. DO NOT MOUNT WALL STATION NEAR OR NEXT TO GARAGE DOOR.

IMPORTANT: THE STANDARD PUSH BUTTON OR THE DELUXE WALL STATION MUST BE THE ONLY TYPE USED FOR PROPER DOOR OPERATION. THE USE OF AN ILLUMINATED PUSH BUTTON OR WALL CONTROL STATION NOT SUPPLIED BY WAYNE-DALTON COULD CAUSE OPENER TO MALFUNCTION.

Wired Wall Station:

Wire the garage door opener wall station using bell wire connected to COM and P.B. screws, as illustrated.

Locate push button adjacent to service entrance door at a minimum height of 5 ft., and at least 6 ft. away from garage door.

Fasten the wall station in a safe location with the (2) phillips head screws, making sure not to over tighten. Pilot drill mounting holes using a 3/32" bit. Additional wired wall stations may also be installed in accordance with these instructions.

CAUTION: Over tightening the screws could deform plastic case.

IMPORTANT: CONNECT THE LOW VOLTAGE WIRE TO THE WALL STATIONS USING A "J" HOOK CONFIGURATION. IF WIRE IS COMPLETELY LOOPEd AROUND TERMINAL SCREW, IT CAN PREVENT PROPER CONTACT.

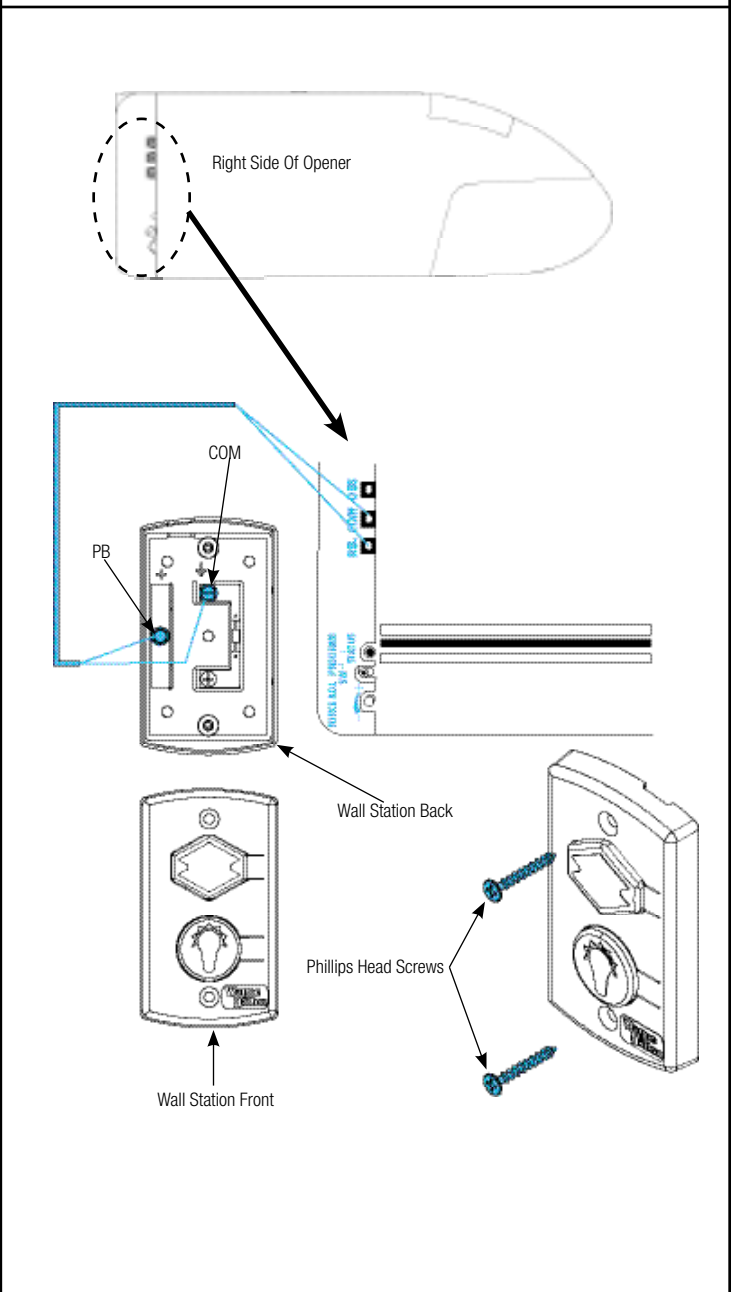
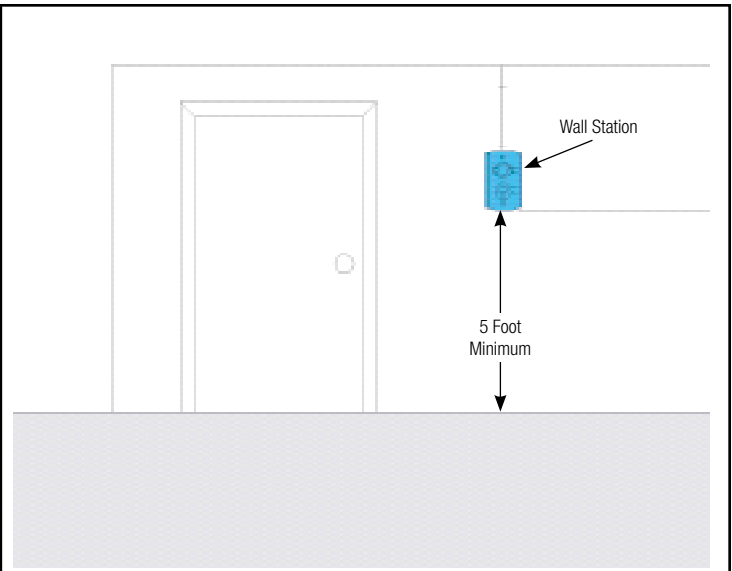

9

Deluxe Multi-Function Wireless Wall Station Installation (If Included)

Tools Needed:

Power Drill

3/32" Drill Bit

Phillips Head Screwdriver

WARNING

TO PREVENT POSSIBLE INJURY, INSTALL WALL STATION OUT OF THE REACH OF CHILDREN AND IN A LOCATION WHERE THE DOOR CAN BE SEEN WHEN THE OPENER IS ACTIVATED. DO NOT MOUNT WALL STATION NEAR OR NEXT TO GARAGE DOOR.

NOTE: For proper operation, mount the wall station on a flat surface.

The wall station can be mounted to a NEMA standard electrical box or directly to any wall surface. No wiring is required.

Locate wall station adjacent to service entrance door at a minimum height of 5 ft., and at least 6 ft. away from garage door.

If mounting to a NEMA electrical box, use machine thread screws provided in place of the wood screws. No drilling is required. If high voltage wiring is contained in the box, a standard NEMA solid faceplate must be installed between the box and the wall station. If fastening into drywall or concrete, use anchors provided. When mounting to wood use a 3/32" drill bit and the drilling template located on page 39. Drill the two 3/32" mounting holes using the drill template. Drill 3/16" holes if using anchors.

Install lower screw leaving 3/16" of the screw exposed. Slide wall station keyhole slot onto the lower phillips head screw. Wall station should slide onto screw, providing a snug fit. If necessary remove wall station and loosen or tighten lower phillips head screw until a snug fit is achieved.

Once wall station is fitted on lower screw, install upper screw. Do not over-tighten.

CAUTION: Over tightening the upper screw could deform plastic case.

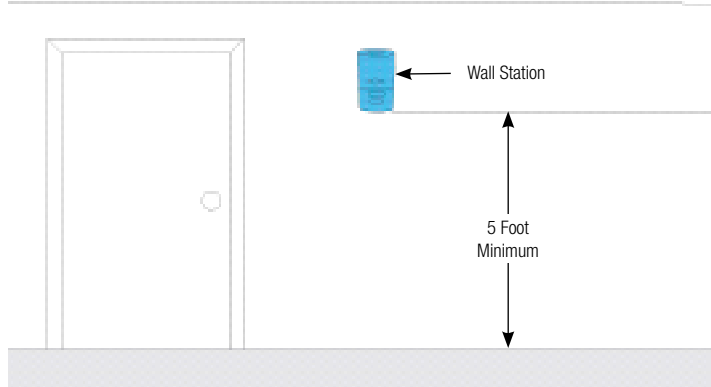

Lower Screw Installation

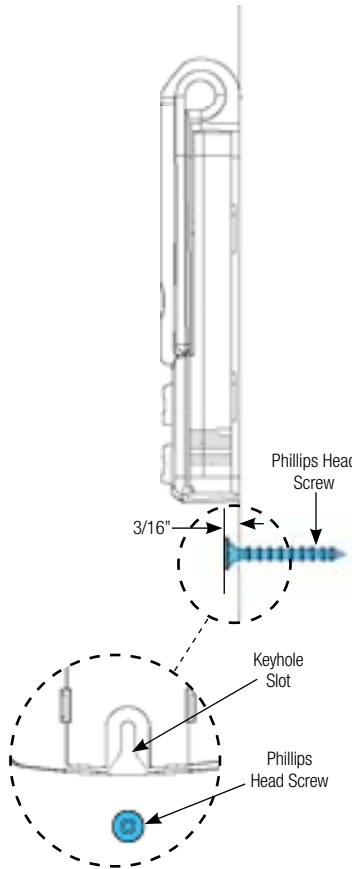

Upper Screw Installation

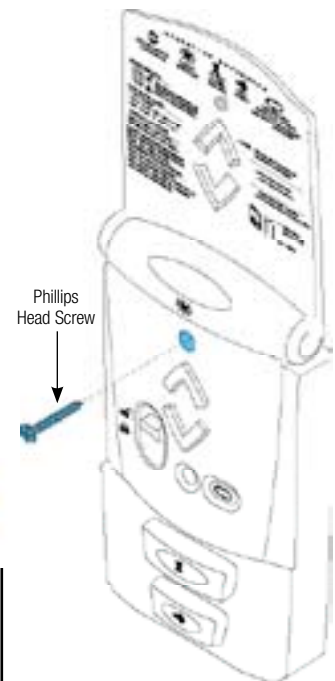

	<p>Deluxe Multi-Function Wireless Wall Station Installation Continued (If Included)</p>	
	<p>Remove the battery cover (right-hand side of wall station) by disengaging the battery cover's lower clip. Install two AAA batteries into the wall station observing the polarity, (+) and (-), of both batteries. After about three seconds, the Up/Down red LED will begin to blink every 5 seconds. Re-install the battery cover by first inserting its top into the wall station then inserting and securing its bottom.</p> <p>NOTE: To slow blink rate or turn off, refer to wall station operation page 28 "Back Lit LED Lights".</p>	

<h1>10</h1>	<p>Entrapment Warning Label</p>	
<p>Tools Needed:</p> <p>None</p>	<p>Apply entrapment label in a convenient location next to the wall station. Use mechanical fasteners if adhesive will not adhere.</p>	

11

Wired Infrared Safety Sensor Installation

Tools Needed:

Ratchet Wrench

Tape Measure

Power Drill

3/16" Drill Bit

7/16" Socket Driver

7/16" Wrench

Pencil

IMPORTANT: BOTH WALL BRACKETS MUST BE MOUNTED AT THE SAME HEIGHT FOR PROPER ALIGNMENT.

Note: Use Steps a-c for installing sensors on both sides of the garage door.

a. Select and mark with a pencil, a mounting location no more than 5 inches above the floor to center line of wall mounting bracket. The safety sensors should be mounted as close to the door track or inside edge of the door as possible to offer maximum entrapment protection. It is very important that both wall mounting brackets be mounted at the same height for proper alignment.

b. Drill pilot holes, using a 3/16" drill bit. Using two 5/16" x 1-1/2" lag screws, permanently mount the wall mounting brackets to both door jambs. In some installations it may be necessary to attach a wooden spacer to the wall to achieve the required alignment.

Attach the "U" brackets to the wall mounting brackets with 1/4"-20 x 1/2" carriage bolts, washers and nuts. Insert the bolts from the inside of the "U" bracket and hand-tighten.

IMPORTANT: IDENTIFY WHICH SIDE OF THE GARAGE DOOR IS EXPOSED TO THE MOST SUNLIGHT. MOUNT THE SENDING UNIT (UNIT WITHOUT LED) ON THE SIDE WHICH IS EXPOSED TO THE MOST SUN. SUNLIGHT MAY AFFECT THE SAFETY SENSORS, AND THIS ORIENTATION WILL HELP REDUCE THE EFFECT.

c. Attach the sending and receiving safety sensors to the "U" brackets by inserting all three tabs into the respective holes.

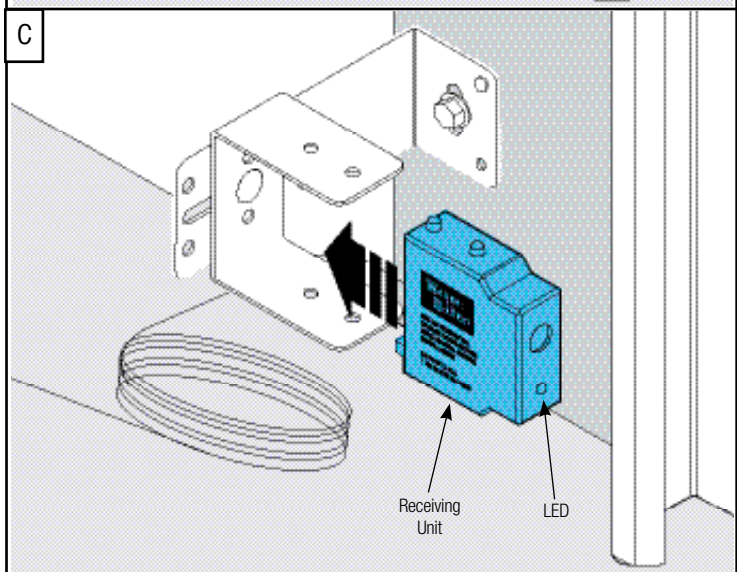
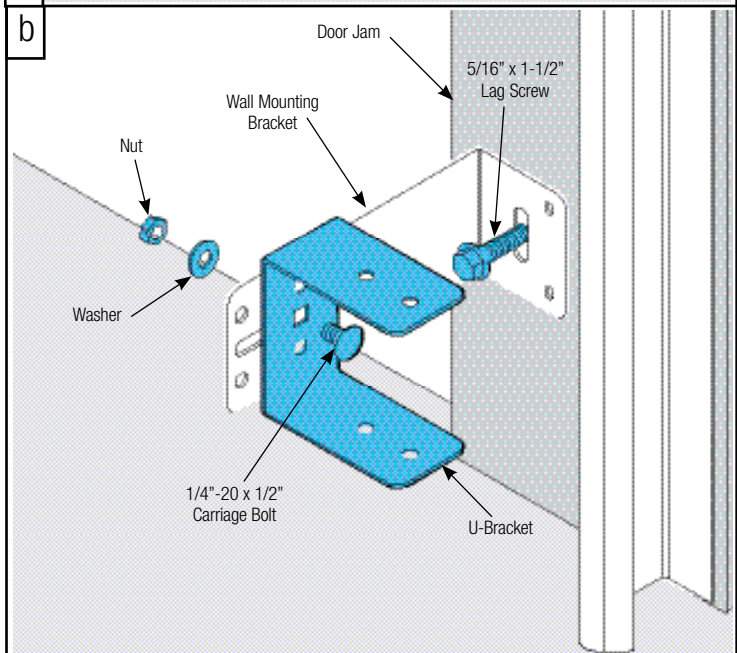
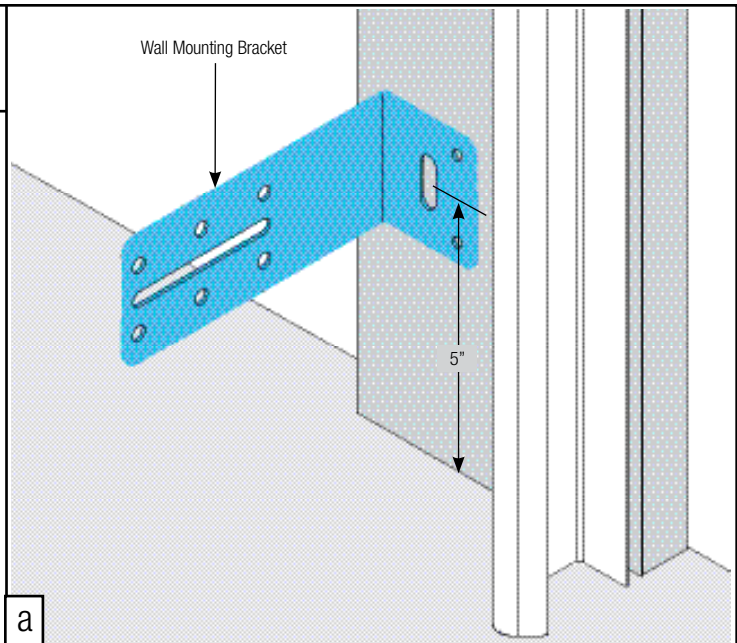

12

Installation of Wiring for Wired Infrared Safety Sensor

Tools Needed:

Hammer

Uncoil the wires from the infrared safety sensors and route the wire up the garage wall across the ceiling and down to the back of the opener. Tack the wires in place using staples (Not Supplied). Take care to run the wires in a location where they will not interfere with the operation of the door and do not staple through wire.

NOTE: If wires must be lengthened or spliced into pre wired installation, use wire nuts or other suitable connectors.

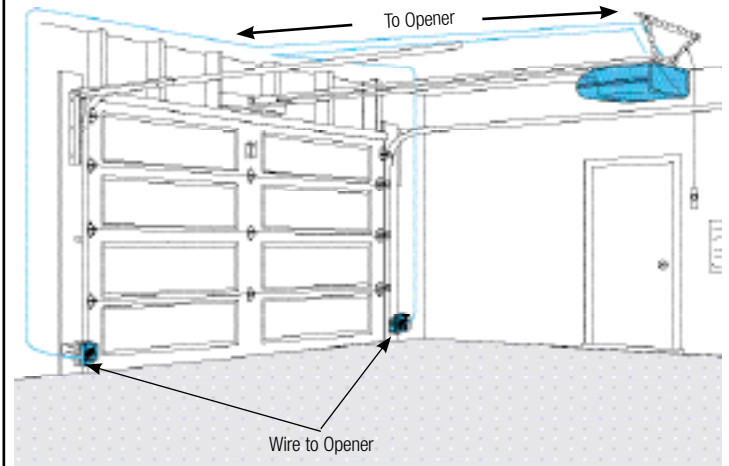

13

Connecting Wired Infrared Safety Sensor to Opener

Tools Needed:

Phillips Head Screwdriver

Connect infrared safety sensors to the opener as shown. Shorten wires as necessary and separate wire ends. Strip about 1/2" of insulation off each wire, being careful not to nick wires, and attach wires to the proper terminal screws, then tighten securely, using phillips head screwdriver.

One wire has marking on it (numbers, black stripe, etc). Be sure to observe polarity. Apply tension to external wires to test for secure connection. Check that the wires are stapled in place properly.

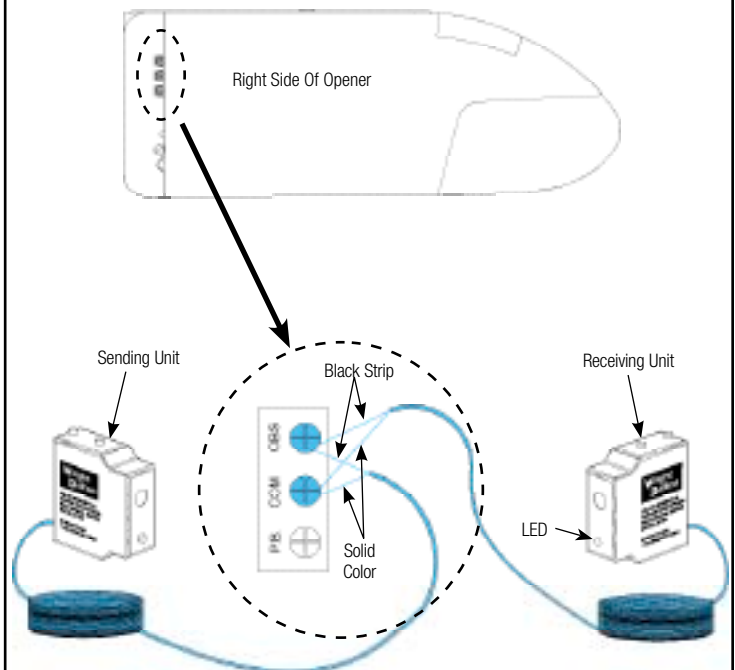

14

Connecting Opener To Outlet

Tools Needed:

None

WARNING

TO REDUCE THE RISK OF ELECTRICAL SHOCK, DO NOT CHANGE THE POWER CORD IN ANYWAY.

IMPORTANT: THE OPENER MUST BE CONNECTED TO A PROPERLY GROUNDED 3 PRONG, 120 VOLT OUTLET.

The opener can be permanently wired. To permanently wire the unit, see permanent wiring option on page 20.

Plug the power cord into the closest grounding type receptacle. Excess power cord length must be routed and contained safely away from any moving parts.

As soon as power is applied to the opener, the light on the opener will blink once to indicate a successful self-check of the controls.

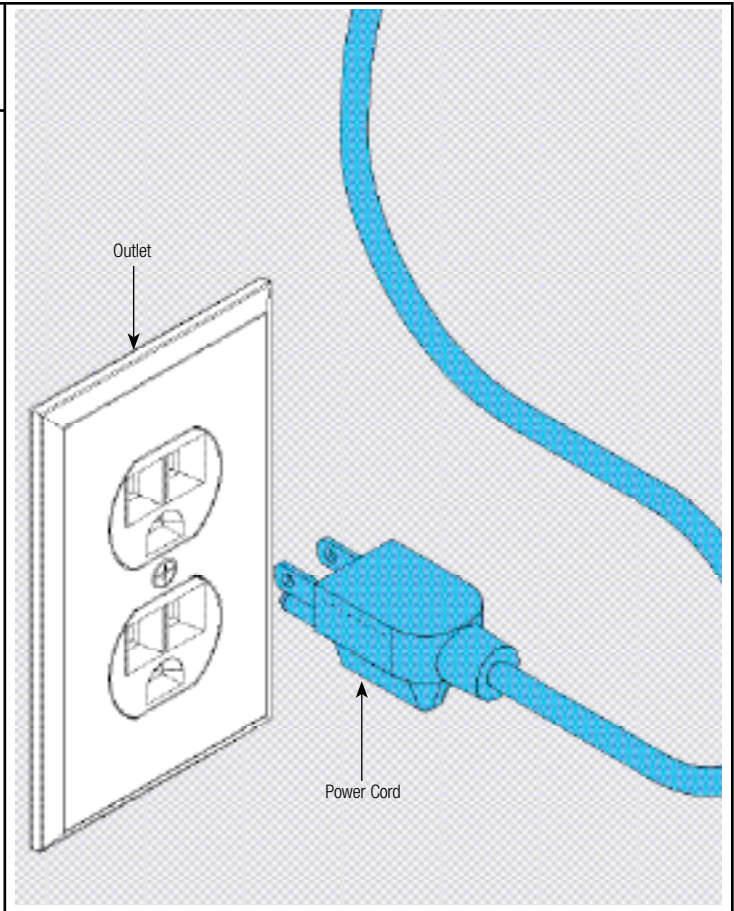

15

Connecting Trolley To Latch Assembly

Tools Needed:

None

Slide the trolley until it snaps onto the latch assembly.

Attach warning label to the red release cord. Thread the red release cord through the pull knob so knot is inside pull knob. Tie a double knot at the end of the red release cord to secure pull knob.

NOTE: Pull knob should hang 6 feet above floor. Ensure that the rope and handle clear the tops of all vehicles to avoid entanglement.

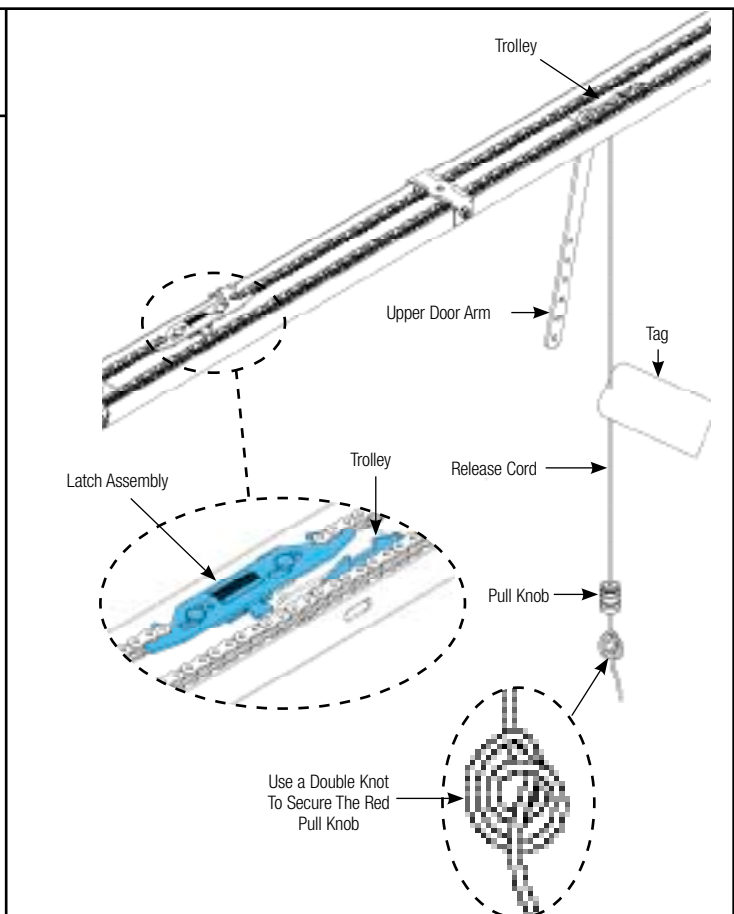

16

Alignment of Wired Infrared Safety Sensors

Tools Needed:

Pliers

WARNING

TO AVOID POSSIBLE SEVERE OR FATAL INJURY, KEEP PEOPLE AND OBJECTS CLEAR OF THE MOVING DOOR ARM TO PREVENT POSSIBLE PERSONAL INJURY.

IMPORTANT: THE SAFETY SENSOR SENDS AN INVISIBLE BEAM OF LIGHT FROM THE SENDING UNIT TO THE RECEIVING UNIT ACROSS THE PATHWAY OF THE DOOR. THE OPENER WILL NOT OPERATE UNTIL THE SAFETY SENSORS ARE CONNECTED TO THE OPENER AND PROPERLY ALIGNED. IF THE INVISIBLE BEAM OF LIGHT IS OBSTRUCTED, AN OPEN DOOR CANNOT BE CLOSED BY THE TRANSMITTER OR A MOMENTARY ACTIVATION OF THE WALL STATION UP/DOWN BUTTON. HOWEVER, THE DOOR MAY BE CLOSED BY CONTINUOUSLY HOLDING YOUR FINGER ON THE WALL STATION UP/DOWN BUTTON (CONSTANT PRESSURE) UNTIL THE DOOR TRAVELS TO A FULLY CLOSED POSITION.

At this point you will be able to activate the opener. The trolley/ upper arm will move to the open position, but will not move to the closed position unless the beams are aligned.

The safety sensors must be aligned by moving the sending and receiving units in or out until the alignment light on the receiving unit comes on. The 1/4"-20 carriage bolt can be loosened to move the unit in or out, as required. If you have difficulty aligning beams, check that both brackets are mounted at the same height (see Step 11) and remount if necessary. Additional minor adjustments can be made by lightly bending the mounting brackets.

Once the alignment light comes on, tighten all bolts and mounting screws.

Finish securing all wiring making sure not to break or open any of the conductors. Loop and secure any extra wire.

Using the wall station up/down button, activate the opener and check that it will operate through full open and close. Ensure trolley and trolley latch are in the closed position prior to proceeding to next step.

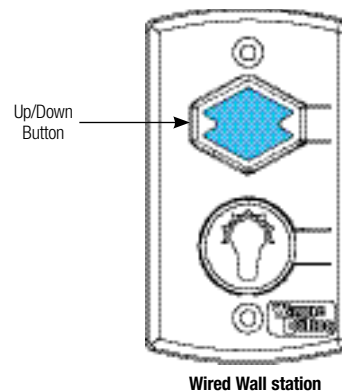
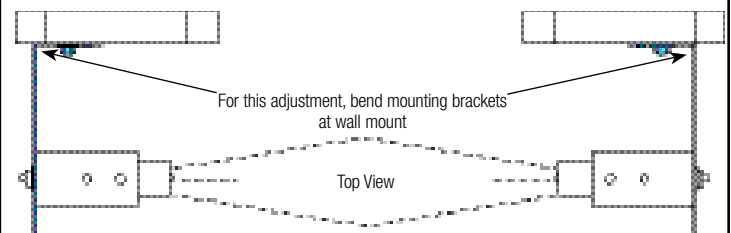
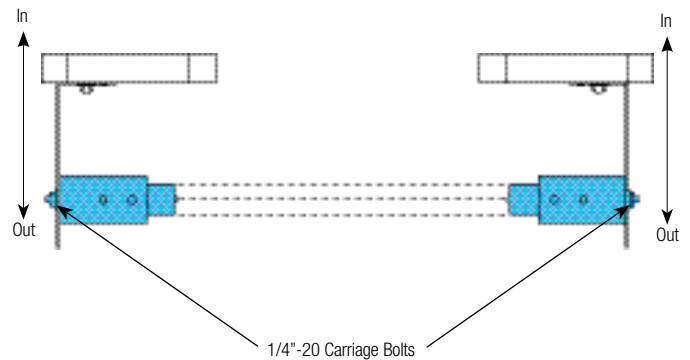

Wired Wall station

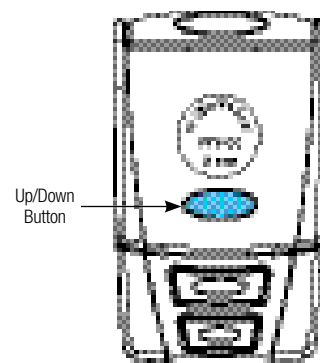

Multi-Function Wall Station RF Transmitter

17

Setting Trolley Close Position

Tools Needed:

Pliers/Wire Cutters

Tape Measure

Flat Tip
Screwdriver

WARNING

TO AVOID POSSIBLE INJURY OR PROPERTY DAMAGE, KEEP PEOPLE AND OBJECTS CLEAR OF THE MOVING DOOR ARM.

NOTE: If necessary, activate the opener to move the trolley/ upper door arm to the closed position.

NOTE: If you have a 9100, 9400, 9600, 5120, 5140 or 9700 series door, with one of the door brackets shown at the right and a Torquemaster® or Extension Spring(s) counterbalance system, see "Setting Trolley Close Position/ Connecting Door Arm To Door" on pages 23-24. If not, complete this step.

NOTE: If you have a 9100, 9400, 9600, 5120, 5140 or 9700 series door, with one of the door brackets shown at the right and a Torsion Spring(s), see "Setting Trolley Close Position/ Connecting Door Arm To Door" on pages 25-26. If not, complete this step.

Trolley and latch assembly must be at the factory preset fully closed position, (see illustration).

Verify preliminary trolley and latch assembly close position is 11" to 13" between trolley clevis pin and the inside face of the door.

If adjustment of the trolley/latch assembly position is required, use the close travel adjustment screw located on the bottom of the opener. A 1/4 turn equals approximately 1" of trolley travel; turn clockwise to decrease distance between header and trolley and counter-clockwise to increase distance between header and trolley.

Single and Double Tab Door Brackets

Models: 9100, 9400, 9600, 5120 and 5140.

Model: 9700

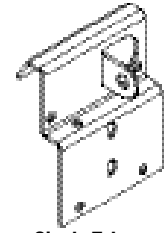
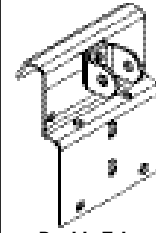
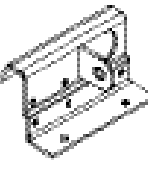
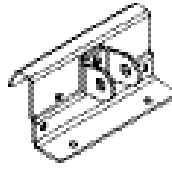

Double Tab
Bracket

Single Tab
Bracket

Double Tab
Bracket

Single Tab
Bracket

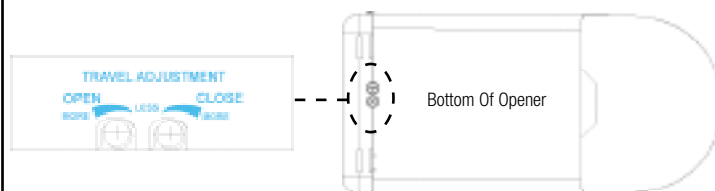
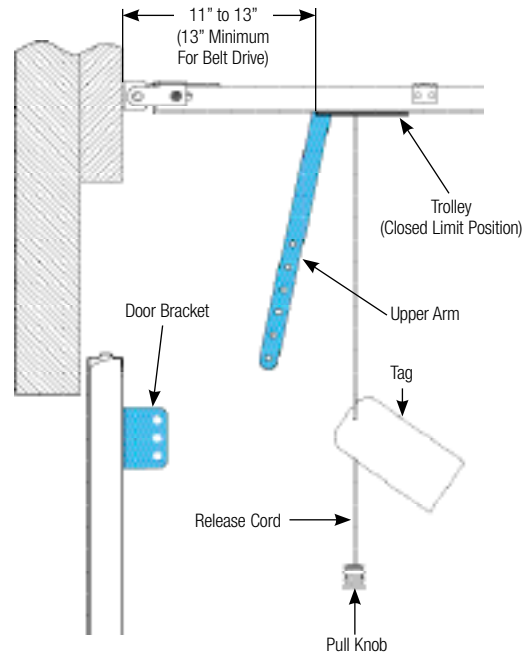

18

Connecting Door Arm to Door

Tools Needed:

Adjustable Wrench

Ratchet Wrench

7/16" Socket

9/16" Socket

Typical Installation:

Place nylon shoulder bushing in lower arm hole in curved end (single hole). Place door arm on right side of door bracket. Insert 5/16" x 1-1/4" multi-grip clevis pin through nylon shoulder bushing, lower door arm and middle hole of door bracket. Install hairpin cotter through hole (Closest to door bracket) of multi grip clevis, as shown.

For Models: 9100, 9400, 9600, 5120, 5140 And 9700

Place nylon shoulder bushing in lower arm hole in curved end (single hole). Place the lower door arm between the tabs (or the right side of single tab) and insert 5/16" x 1-1/4" multi-grip clevis pin through nylon shoulder bushing, lower door arm and hole(s) of door bracket. Install hairpin cotter through hole (Closest to door arm "Double Tab" or door bracket "Single Tab") of multi grip clevis, as shown.

For Models: 9700 And 9800

Place nylon shoulder bushing in lower arm hole in curved end (single hole). Place the lower door arm between the tabs and insert 5/16" x 1-1/4" multi-grip clevis pin through nylon shoulder bushing, lower arm and holes of door bracket. Install hairpin cotter through hole (Closest to door arm) of multi grip clevis, as shown.

CONNECTING UPPER AND LOWER DOOR ARMS

WARNING

FAILURE TO USE LOCKING NUT CAN RESULT IN ARM RELEASING AND POSSIBLE RESULTING IN PROPERTY DAMAGE AND/OR PERSONAL INJURY.

Align upper and lower door arm pieces to nearest matching holes.

NOTE: It may be necessary to apply downward pressure on the door or slightly raise the door during this process.

Secure upper and lower door arms to each other using two 1/4"-20 x 3/4" hex head bolts and nylock nuts.

NOTE: Install the hex head bolts as far apart as possible, when positioning the upper and lower arms.

NOTE: Door arm angle must be 10° to 30° degrees (see illustration). If not, repeat "Setting Trolley Close Position" and increase or decrease distance between trolley clevis pin and inside face of the door.

Typical Installation

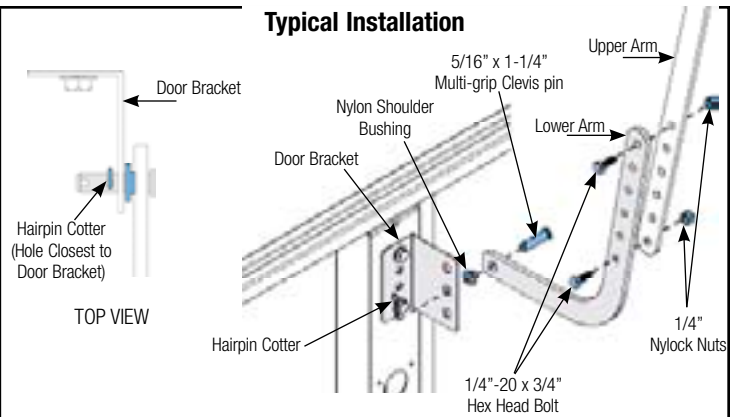

Models: 9100, 9400, 9600, 5120, 5140 or 9700

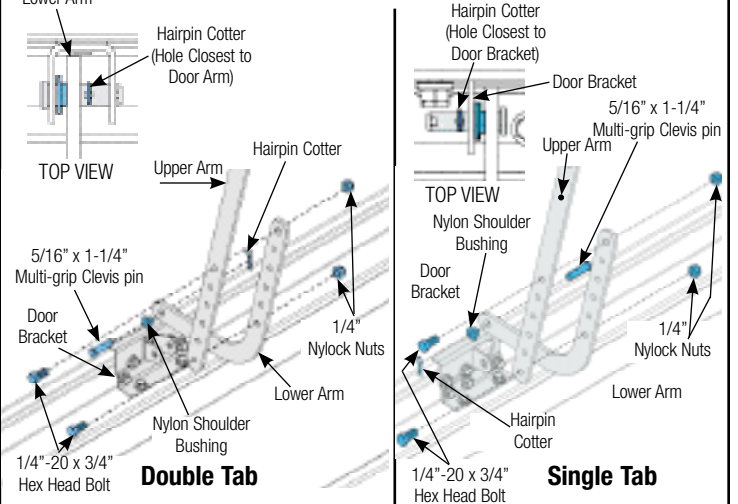

Models: 9700 And 9800

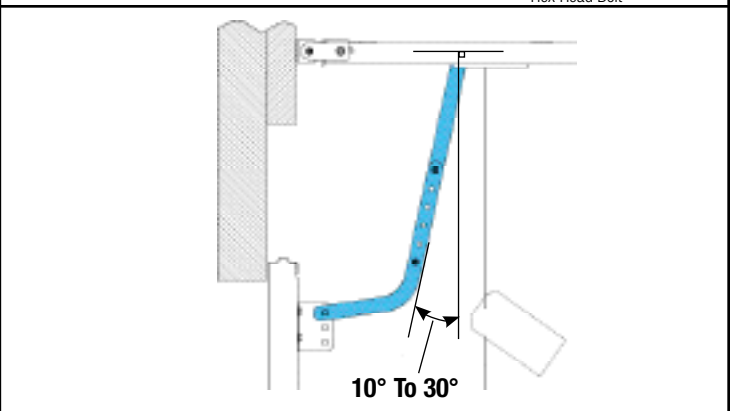
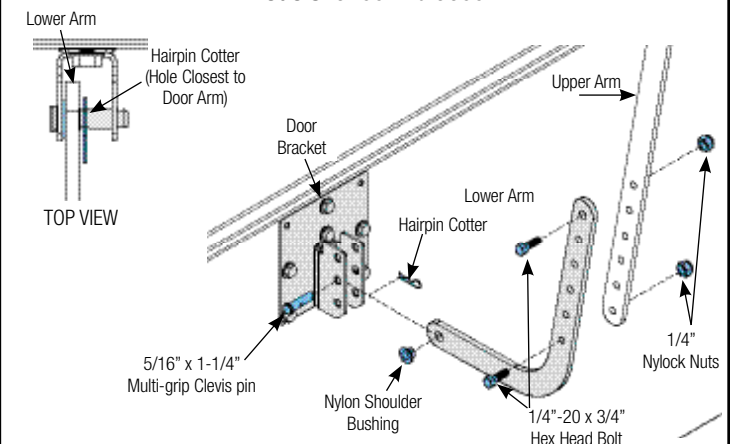

19

Setting Door Close Travel

Tools Needed:

Flat Tip
Screwdriver

Using the wall control up/down button, activate door to full open position; reactivate to close position.

The door should stop on the floor with the bottom door seal slightly compressed.

If the door reverses off the floor, turn close travel knob 1/4 turn "less".

If door is not completely closed, turn travel knob 1/4 turn "more".

Repeat as necessary.

NOTE: 1/4 turn equals 1" of door travel.

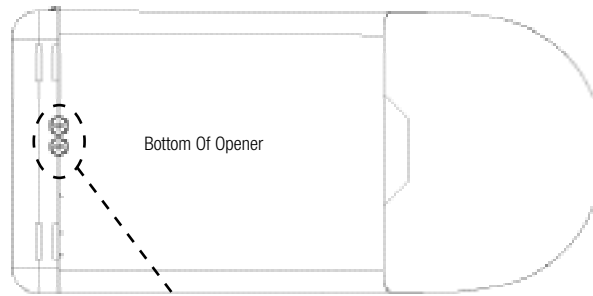

20

Setting Door Opening Travel

Tools Needed:

Flat Tip
Screwdriver

The door opener is assembled with the open travel adjustment preset for a typical door, but all doors should be adjusted to stop as close as possible to the door's "natural" fully open, resting position.

To determine the door's "natural" fully open, resting position, disconnect door from opener using the emergency release disconnect (see page 27, EMERGENCY DISCONNECT) and manually raise door to its "natural" fully open, resting position. Use this location for your open limit setting. To determine if door needs adjustment, activate the opener to bring door to fully open position.

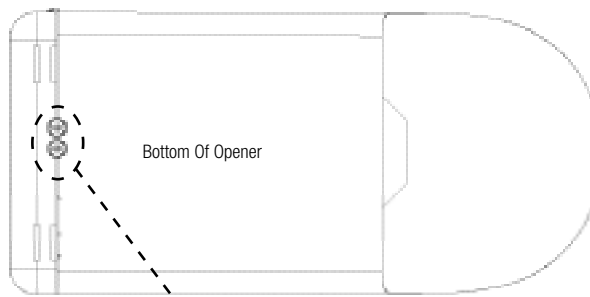

Setting Door Opening Travel (Continued)

NOTE: If door does not open fully and opener light flashes (make sure the bulb is installed and operating) check for an obstruction or see Adjustment #1, page 32 (Adjusting Opening Force).

To adjust for a non-standard door or to precisely set the open position: Using the wall station, operate the door and stop it in mid-travel position. Using a flathead screwdriver turn the OPEN travel adjuster for more (counter-clockwise) or less (clockwise) travel. A 1/4 turn equals approximately 1" of trolley movement.

NOTE: Confirm that the door has stopped in the UP position as a result of the upper limit switch and not because the trolley has hit the stop bolt, which is mounted in the rail near the opener. The correct condition can be verified by observing that the openers convenience light does not flash after the fully open door comes to a stop. The faulty condition may also be confirmed visually by checking to see if the trolley is resting against the stop bolt.

To confirm final OPEN travel adjustment, activate the opener to bring door to fully open position. The opener light should not be flashing.

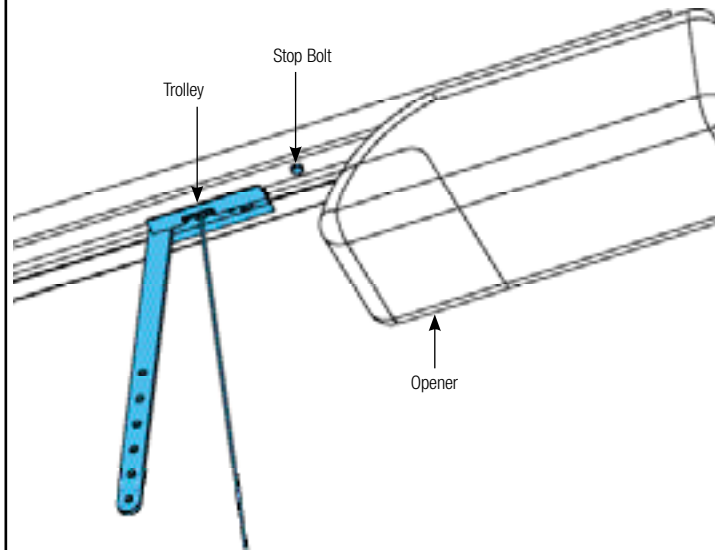

21

Contact Obstruction Test

Tools Needed:

2 x 4 Board

After installing the opener, the door must reverse when it contacts a 1 1/2" inch high object (or a 2 x 4 board laid flat) on the garage floor.

Using the wall station, activate the door to the fully open position. Place a 2 x 4 flat on the garage floor, under the door path. Activate the door to the closed position with the wall station. Upon contacting the 2 x 4 board, the door should reverse.

If door stops on the 2 x 4 board, adjust the close travel knob 1/8-1/4 turn "more" until door reverses upon contact with 2 x 4 board.

When the door reverses, remove the 2 x 4 board and run the full cycle of open and close of the door. Door should not reverse when it comes to the fully closed position on the floor.

NOTE: If opener fails to pass this test, repeat Step 19. Also see Adjustment #2, page 32 (Contact Obstruction Test).

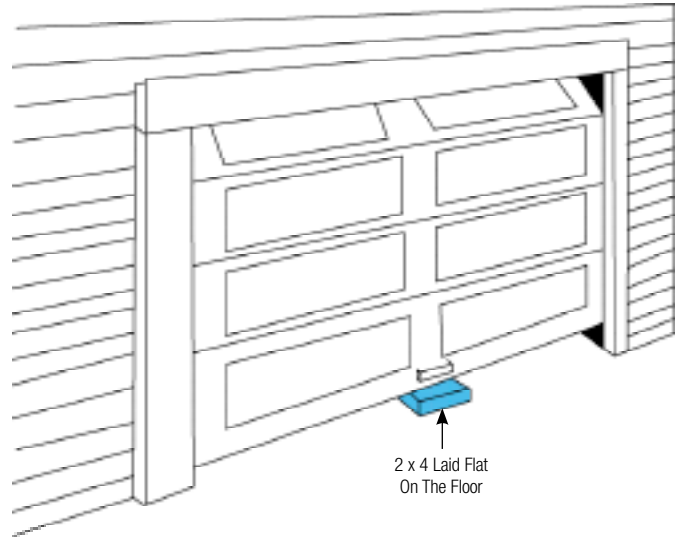

WARNING

IF OPENER DOES NOT RESPOND PROPERLY TO THESE TESTS (STEPS 21 AND 22), HAVE A QUALIFIED SERVICE PERSON MAKE NECESSARY ADJUSTMENTS/REPAIRS, OR SEVERE OR FATAL INJURY COULD RESULT FROM OPERATING THE DOOR/OPENER.

22

Safety Sensor Obstruction Test

Tools Needed:

2" x 6" x 12"
Solid Test Object

WARNING

WHEN PERFORMING THIS PART OF THE TEST, DO NOT PLACE YOURSELF UNDER DESCENDING DOOR, OR SEVERE OR FATAL INJURY MAY RESULT.

Starting with the door fully open, place a 6" high object on the floor, in line with sensors, 12" from the left side of the door.

Activation of the opener with the wall station Up/Down button should cause the door to move no more than one foot, stop and then reverse to fully open position.

Repeat this test with the 6" high object placed at the center of the door and then 12" from the right side of the door.

The 6" high object, when placed on the floor in line with sensors, while door is closing, should also cause the door to reverse.

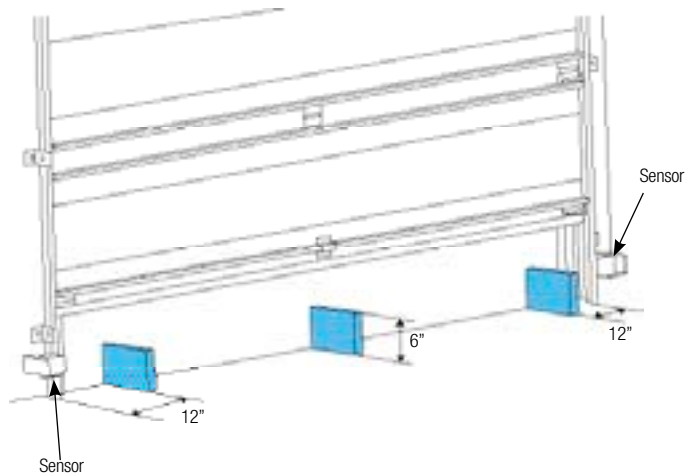

WARNING

IF OPENER DOES NOT RESPOND PROPERLY TO THESE TESTS (STEPS 21 AND 22), HAVE A QUALIFIED SERVICE PERSON MAKE NECESSARY ADJUSTMENTS/REPAIRS, OR SEVERE OR FATAL INJURY COULD RESULT FROM OPERATING THE DOOR/OPENER.

Programming Wireless Keyless Entry (If Included)

Tools Needed:

None

WARNING

DURING PROGRAMMING THE GARAGE DOOR MAY OPERATE. KEEP PEOPLE AND OBJECTS CLEAR OF THE MOVING DOOR TO PREVENT DOOR DAMAGE OR POSSIBLE PERSONAL INJURY.

NOTE: To simplify installation, program the wireless keyless entry to the opener before mounting to the wall.

NOTE: Before programming ensure garage door is in the "down" position.

1. Press and release the PROGRAM button. The red PROGRAM STATUS light on the opener and the overhead lamp will turn on and remain lit for one minute, indicating that it is ready to learn the keyless entry.

2. Press the desired five digit PIN (PERSONAL IDENTIFICATION NUMBER), example 1-3-8-2-5. The PROGRAM STATUS light will turn on and off three times indicating a successful learn.

NOTE: Do not set a code that presents the numbers in sequential order, as an example 1/2, 3/4, 5/6, 7/8, 9/0. Studies show that people naturally press the buttons in a sequential pattern. Also, do not select a code that uses the same button five times consecutively. Thieves can easily figure out these types of codes.

NOTE: If at anytime, an error was made entering the code, simultaneously press and release the 7/8 and 9/0 buttons to reset the keyless entry; then repeat programming steps above.

NOTE: A single wireless keyless entry device may be programmed to operate multiple garage door openers. To program additional openers, repeat programming steps using a different five digit PIN for each additional opener.

How Your Keyless Entry Operates Your Door:

The following explains how your Keyless Entry can be used to OPEN, CLOSE, START, and STOP your door.

1. Enter your 5-digit PIN (personal identification number); door will move.

NOTE: If you inadvertently enter an incorrect code, the door will not move. To reset, simultaneously press and release the 7/8 and 9/0 buttons and reenter your PIN number.

2. Unit remains active for next 25 seconds. Pressing any key, will stop the door if opening, and stop or reverse the door if closing during the 25 seconds active period.

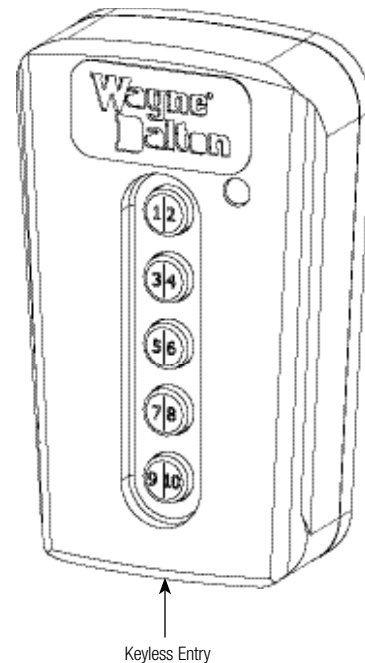
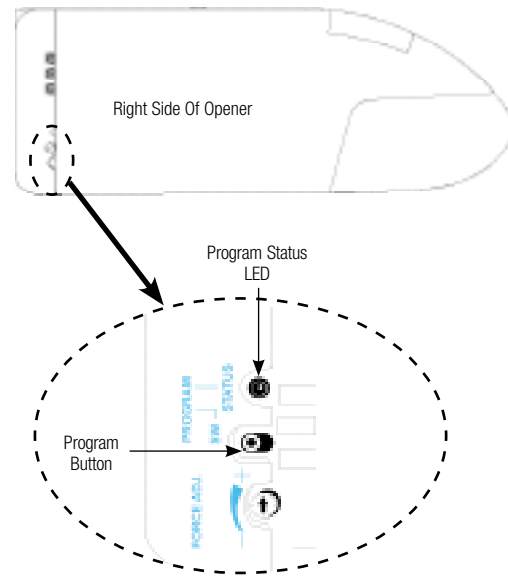

24

Installing Wireless Keyless Entry (If Included)

Tools Needed:

Power Drill

5/64" Drill Bit

Phillips Head
Screwdriver

IMPORTANT: INSTALL ALL WALL CONTROLS OUT OF THE REACH OF CHILDREN AND IN A LOCATION WHERE THE DOOR CAN BE SEEN BEFORE ACTIVATING.

Locate a convenient place to mount the wireless keyless entry, that does not interfere with the normal opening and closing of the door. To keep keyless entry out of the reach of children, measure and mark a spot at least 5 feet up from the floor. Use the drilling template located on Page 39 to determine hole positions. Drill 5/64" pilot holes 3/4" deep at each screw location.

Snap open the wireless keyless entry case with a coin. Secure keyless entry base into wood framing using the two screws provided. Snap the front case half back onto the base. Remove paper backing from instruction label and apply to a clean surface inside garage.

NOTE: Two screws are included for mounting to wood structures. Ensure proper hardware is used for mounting to other materials.

NOTE: After completing this step, continue with page 27.

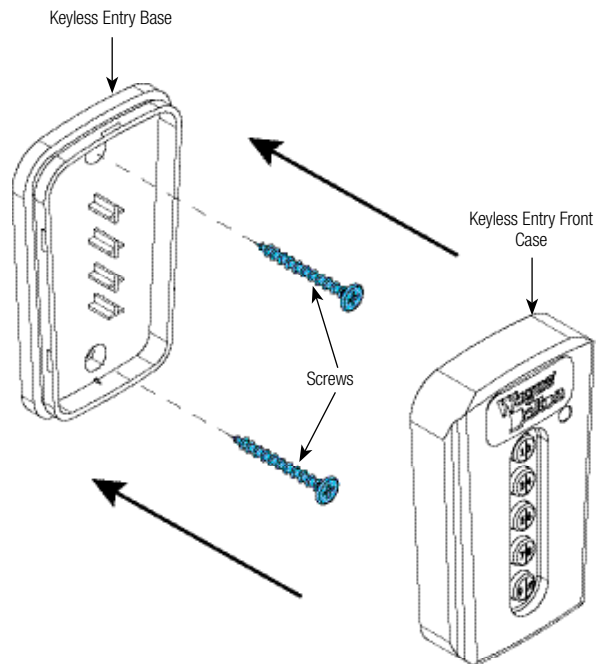
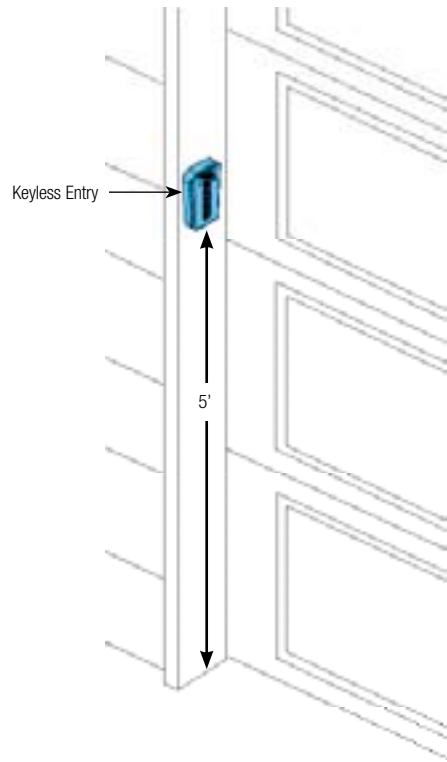



Power Connection (Permanent Wiring Option)

Tools Needed:

Needle Nose Pliers

Pliers/Wire Cutters

Flat Tip
Screwdriver

WARNING

TO AVOID ELECTRICAL SHOCK, DISCONNECT POWER AT THE FUSE/BREAKER BOX BEFORE PROCEEDING.

IMPORTANT: CHECK YOUR LOCAL ELECTRICAL CODES. IF YOUR LOCAL CODE REQUIRES PERMANENT WIRING, USE THE SPECIFICATIONS CALLED FOR AND INSTRUCTIONS ILLUSTRATED.

Permanent Wiring Procedure

1. Ensure power cord is disconnected from electrical power.
2. Cut power cord 1/2" – 1" from strain relief/bushing.
3. Use needle nose pliers to remove strain relief bushing from frame. Squeeze tabs in on underside of bushing and work bushing out of hole.
4. Pull or strip off remaining section of outer insulation from power cord.
5. Remove lens by pressing up on both sides of the bottom of the lens at the junction of the housing, releasing the locking tabs, and pulling forward; remove light bulb (if installed).
6. Remove the housing from the chassis by removing the screw securing the housing to the chassis. Press on the locking tabs and slide the cover off the chassis.
7. Pull the three wires into the opener; strip 1/2" of insulation from the black, white, and green wires.
8. Using wire nuts for 14-18 AWG wire, connect the black wire to black wire, the white wire to white wire and the green wire to green wire. Make sure connections are secure.
9. Replace opener cover.

Reconnect the power at the fuse/ breaker box, as soon as power is applied to the unit, the light on the opener will blink once to indicate a successful self check of the controls.

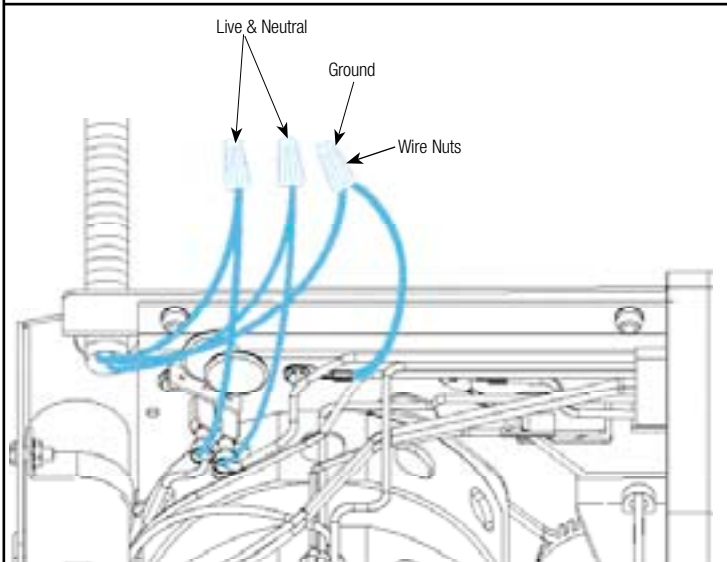
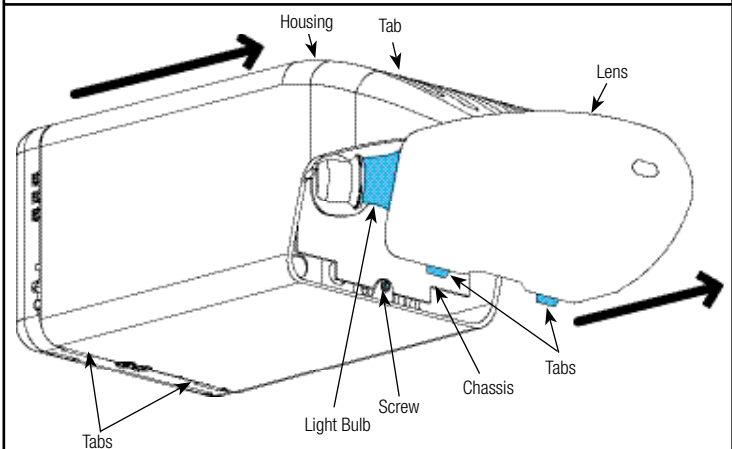
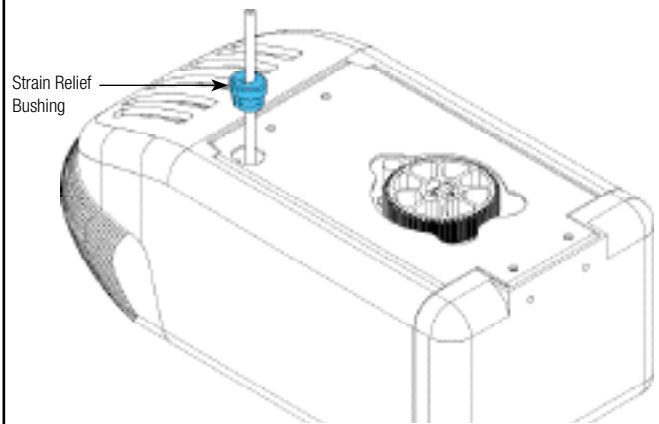
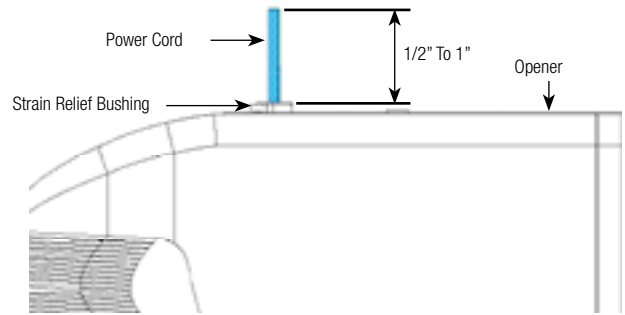



Mounting Door Bracket To A 9700 Series Door

Tools Needed:

Power Drill

7/16" Socket Driver

IMPORTANT: WHEN CONNECTING A TROLLEY TYPE GARAGE DOOR OPENER TO A 9700 SERIES DOOR, A WAYNE-DALTON OPENER/TROLLEY BRACKET MUST BE SECURELY ATTACHED TO THE TOP SECTION OF THE DOOR, ALONG WITH ANY U-BARS PROVIDED WITH THE DOOR. THE INSTALLATION OF THE OPENER MUST BE ACCORDING TO MANUFACTURER'S INSTRUCTIONS AND FORCE SETTINGS MUST BE ADJUSTED PROPERLY.

Locate the center of the top section or factory attached u-bar as shown in FIG 1.1.

FOR TOP SECTION WITH U-BAR:

Remove and retain 4-6 screws from the center of the u-bar, allowing the door bracket to slide between the section and the u-bar.

Position the door bracket until it seats on the male part of the section as shown in FIG 1.2. The door bracket must be centered and positioned on the top section so it bridges the transition point of the section thickness.

Attach the door bracket using 1/4" - 14 x 5/8" self tapping screws as shown in FIG 1.4. Re-attach the u-bar using (2) 1/4" - 20 x 11/16" self drilling screws through the door bracket as shown in FIG 1.3. Finish re-attaching the u-bar using the self tapping screws removed previously.

FOR TOP SECTION WITHOUT U-BAR:

Position the door bracket until it seats on the male part of the section as shown in FIG 1.2. The door bracket must be centered and positioned on the top section so it bridges the transition point of the section thickness. Attach the door bracket using 1/4" - 14 x 5/8" self tapping screws as shown in FIG 1.4.

NOTE: After completing this step, continue with Step 7.

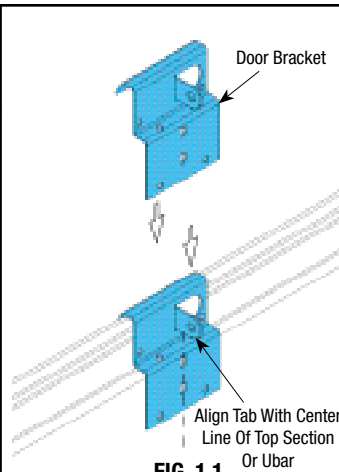

FIG. 1.1

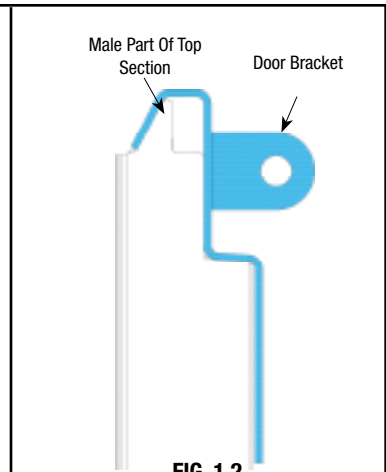

FIG. 1.2

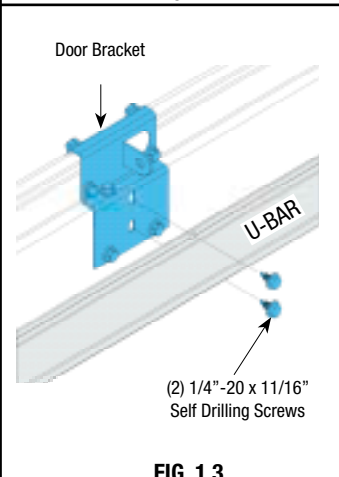

FIG. 1.3

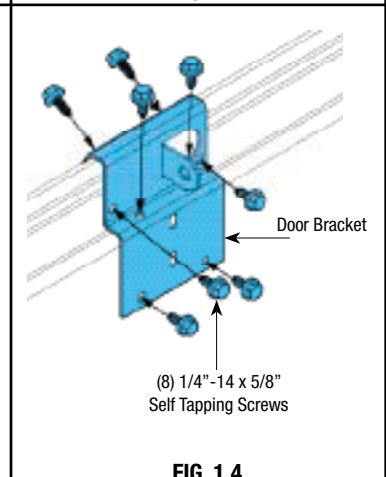
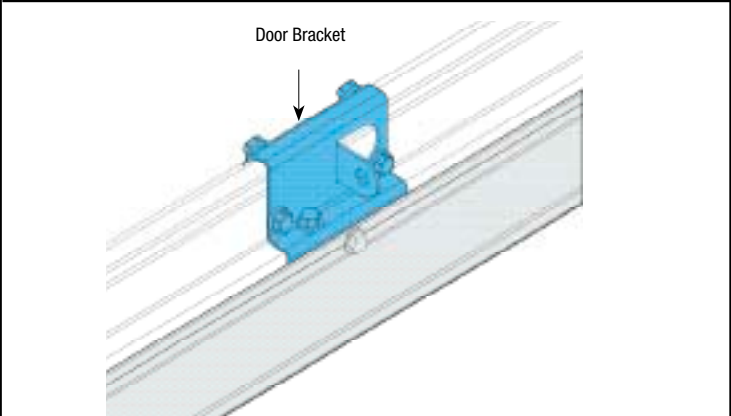
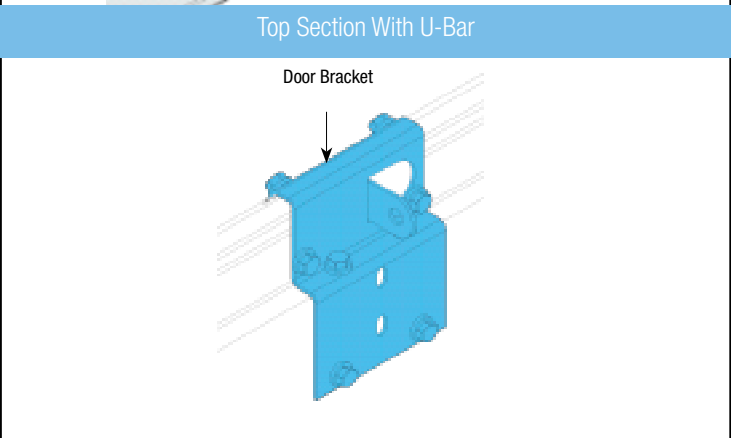

FIG. 1.4



Top Section With U-Bar



Top Section Without U-Bar



Mounting Door Bracket To A (9100, 9400, 9600, 5120 & 5140 Series Door)

Tools Needed:

Power Drill

7/16" Socket Driver

Vice Clamps

Phillips Head Screwdriver

IMPORTANT: WHEN CONNECTING A TROLLEY TYPE GARAGE DOOR OPENER TO THE ABOVE LISTED DOORS, A WAYNE-DALTON OPENER/TROLLEY BRACKET MUST BE SECURELY ATTACHED TO THE TOP SECTION OF THE DOOR, ALONG WITH ANY U-BARS PROVIDED WITH THE DOOR. THE INSTALLATION OF THE OPENER MUST BE ACCORDING TO MANUFACTURER'S INSTRUCTIONS AND FORCE SETTINGS MUST BE ADJUSTED PROPERLY.

Locate the center of the top section and seat the door bracket on male part of the top section. The door bracket must be centered and positioned on top section so it bridges the transition point of the section thickness, as shown in FIG. 1.1 and 1.2. Install (2) #12 x 1/2" phillips head screws on the opposite side of door bracket, as shown in FIG. 1.3. If initially supplied u-bar is on the door, clamp door bracket to u-bar, as shown in FIG. 1.4. First attach (3) 1/4" - 14 x 5/8" self-tapping screws to the door bracket, as shown in FIG. 1.5. Then attach (2) 1/4" - 14 x 5/8" self-tapping screws to the door bracket, as shown in FIG. 1.6. Remove vice clamps.

NOTE: If you have a 9100 door, you can use two of the 1/4" - 20 x 11/16" self-drilling screws used to attach the u-bar instead of the 1/4" - 14 x 5/8" self-tapping screws when attaching door bracket to u-bar, as shown in FIG. 1.6.

NOTE: When attaching door bracket to top section with u-bar, apply additional pressure to thread fasteners into the u-bar.

NOTE: See FIG. 1.7 for installing door bracket on top section without u-bars.

NOTE: After completing this step, continue with Step 7.

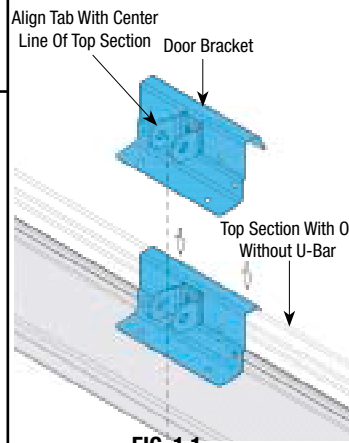

FIG. 1.1

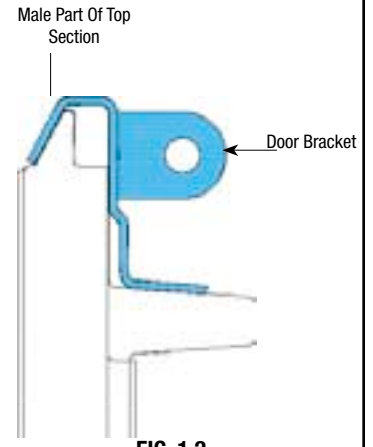

FIG. 1.2

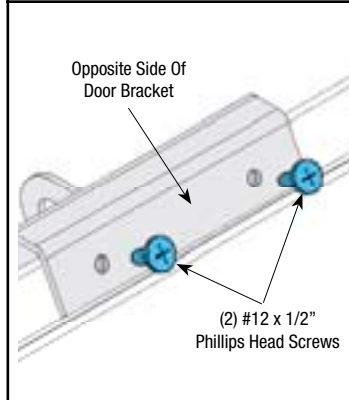

FIG. 1.3

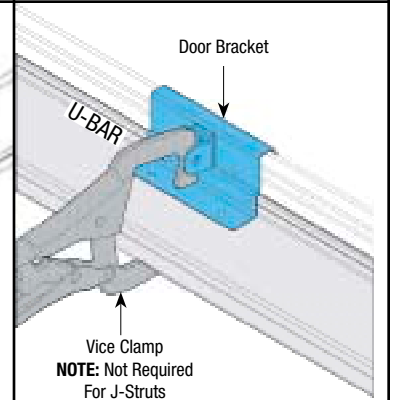

FIG. 1.4

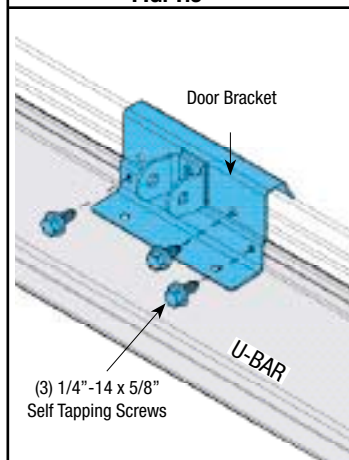

FIG. 1.5

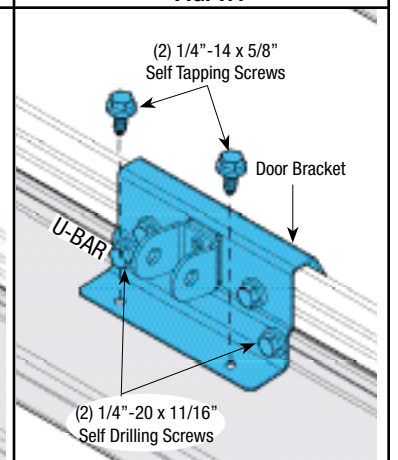

FIG. 1.6

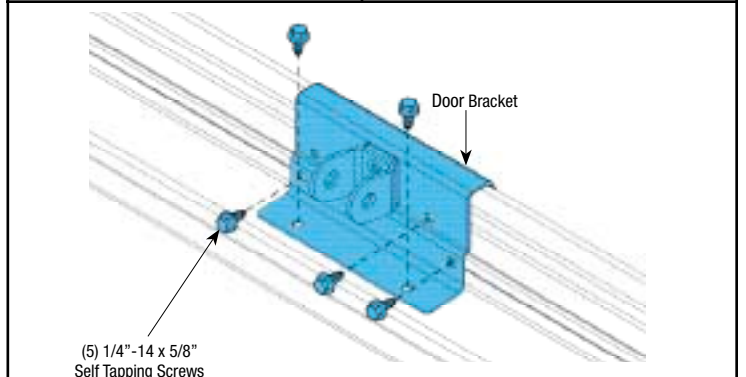

Fig. 1.7 Top Section Without U-Bar



Setting Trolley Close Position/ Connecting Door Arm

(Models 9100, 9400, 9600, 5120, 5140 & 9700)
With TorqueMaster® Or Extension Springs

Tools Needed:

Needle Nose Pliers

Adjustable Wrench

Ratchet Wrench

7/16" Socket

9/16" Socket

Hacksaw

DETERMINE THE WAYNE-DALTON TRACK RADIUS BEING USED:

FOR MOUNT HOPE AND PENSACOLA TRACK:

Measure the curved ends of the horizontal track to determine if you have a 12" or 15" radius horizontal track, as shown in FIG. 1.

FOR PORTLAND TRACK:

The horizontal tracks are stamped with radius on the side of the horizontal track, as shown in FIG. 1.1.

NOTE: If necessary, remove the upper arm (straight arm) from the trolley, to use the lower arm (curved arm). Remove the hairpin cotter from the clevis pin at the front of trolley and slide clevis pin out far enough to slide the upper arm out between the left and right side of trolley body. Position the lower door arm so the end with the single hole lines up with the clevis pin. Slide clevis pin completely back into trolley and reinstall hairpin cotter.

LOW HEADROOM:

If you have low headroom track, as shown in FIG. 1.6 on page 24, then proceed with "Low Headroom Trolley Positioning Charts" on page 24.

STANDARD LIFT:

Using the **STANDARD LIFT TROLLEY POSITIONING CHARTS**, refer to DIM "X" to set the distance from header to trolley, as shown in FIG. 1.2.

NOTE: Depending on your setup, you may have to cut straight arm to accomplish trolley settings.

STANDARD LIFT TROLLEY POSITIONING CHART FOR (MODELS 9100, 9400, 9600, 5120 & 5140) 10" AND 12" RADIUS

DIM "X"	TYPE OF ARM BEING USED	REFERENCE ILLUSTRATIONS
11 1/2"	CURVED / STRAIGHT	FIG. 1.4

If adjustment of the trolley position is required, use the close travel adjustment screw located on the bottom of the opener, as shown in FIG 1.5 on page 24. A 1/4 turn equals approximately 1" of trolley travel; turn clockwise to decrease distance (forward) and counter-clockwise to increase distance (forward).

NOTE: Proceed with "Connecting Door Arm To Door" Step 18, on page 14.

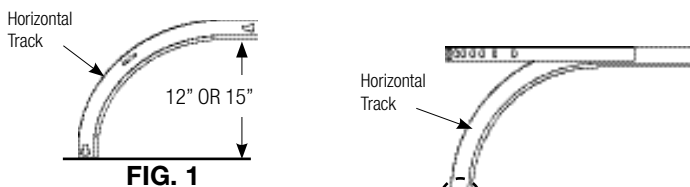

FIG. 1

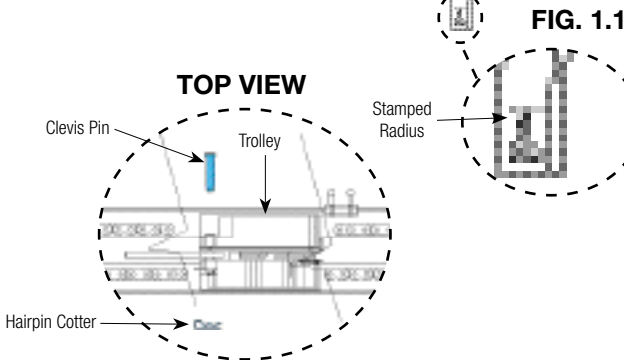

FIG. 1.1

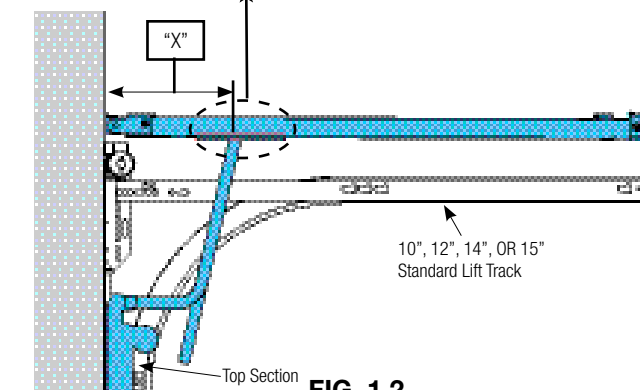

FIG. 1.2

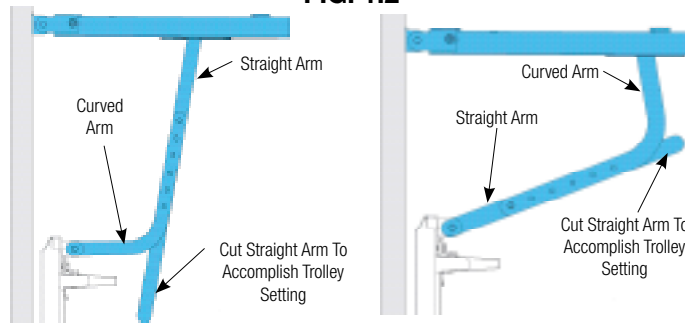

FIG. 1.3

FIG. 1.4

STANDARD LIFT TROLLEY POSITIONING CHART FOR (MODELS 9100, 9400, 9600, 5120 & 5140) 14" AND 15" RADIUS

DIM "X"	TYPE OF ARM BEING USED	REFERENCE ILLUSTRATIONS
13"-15"	CURVED / STRAIGHT	FIG. 1.4

STANDARD LIFT TROLLEY POSITIONING CHART FOR (MODEL 9700) 15" RADIUS

DIM "X"	TYPE OF ARM BEING USED	REFERENCE ILLUSTRATIONS
10 9/16"-14 5/8"	STRAIGHT / CURVED	FIG. 1.3

Setting Trolley Close Position/ Connecting Door Arm (Continued)

LOW HEADROOM:

Using the **LOW HEADROOM TROLLEY POSITIONING CHARTS**, refer to **DIM "X"** to set the distance from header to trolley, as shown in FIG. 1.6.

NOTE: Depending on your setup, you may or may not have to cut straight arm to accomplish trolley settings.

If adjustment of the trolley position is required, use the close travel adjustment screw located on the bottom of the opener, as shown in FIG 1.5. A 1/4 turn equals approximately 1" of trolley travel; turn clockwise to decrease distance (forward) and counter-clockwise to increase distance (forward).

LOW HEADROOM TROLLEY POSITIONING CHART FOR (MODELS 9100, 9400, 9600, 5120 & 5140)

DIM "X"	TYPE OF ARM BEING USED	REFERENCE ILLUSTRATIONS TO THE RIGHT
14 1/2"	CURVED / STRAIGHT	FIG. 1.7
OPTIONAL HOOKUP		
10" - 14"	STRAIGHT	FIG. 1.7a

LOW HEADROOM TROLLEY POSITIONING CHART FOR (MODEL 9700)

DIM "X"	TYPE OF ARM BEING USED	REFERENCE ILLUSTRATIONS
14 3/4"- 17 11/16"	CURVED / STRAIGHT	FIG. 1.7
OPTIONAL HOOKUP		
10" - 14"	STRAIGHT	FIG. 1.7a

NOTE: Proceed with "Connecting Door Arm To Door" Step 18, on page 14.

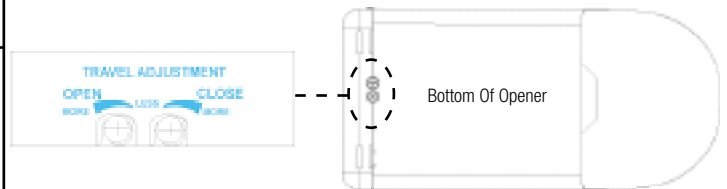

FIG. 1.5

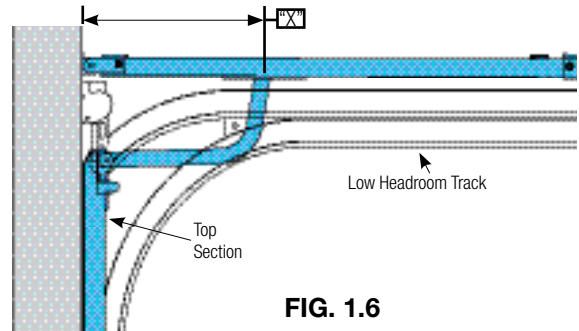

FIG. 1.6

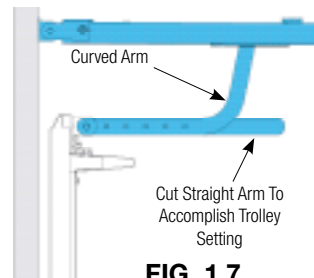

FIG. 1.7

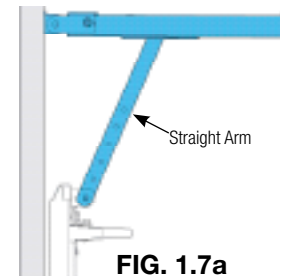

FIG. 1.7a



Setting Trolley Close Position/ Connecting Door Arm

(Models 9100, 9400, 9600, 5120, 5140 & 9700)
With Torsion Springs

Tools Needed:

Needle Nose Pliers

Adjustable Wrench

Ratchet Wrench

7/16" Socket

9/16" Socket

Hacksaw

DETERMINE THE WAYNE-DALTON TRACK RADIUS BEING USED:

FOR MOUNT HOPE AND PENSACOLA TRACK:

Measure the curved ends of the horizontal track to determine if you have a 12" or 15" radius horizontal track, as shown in FIG. 1.

FOR PORTLAND TRACK:

The horizontal tracks are stamped with radius on the side of the horizontal track, as shown in FIG. 1.1.

NOTE: If necessary, remove the upper arm (straight arm) from the trolley, to use the lower arm (curved arm). Remove the hairpin cotter from the clevis pin at the front of trolley and slide clevis pin out far enough to slide the upper arm out between the left and right side of trolley body. Position the lower door arm so the end with the single hole lines up with the clevis pin. Slide clevis pin completely back into trolley and reinstall hairpin cotter.

LOW HEADROOM:

If you have low headroom track, as shown in FIG. 1.5 on page 26, then proceed with "Low Headroom Trolley Positioning Charts" on page 26.

STANDARD LIFT:

Using the **STANDARD LIFT TROLLEY POSITIONING CHARTS**, refer to DIM "X" to set the distance from header to trolley, as shown in FIG. 1.2.

NOTE: Depending on your setup, you may have to cut straight arm to accomplish trolley settings.

STANDARD LIFT TROLLEY POSITIONING CHART FOR 10" AND 12" RADIUS FOR (MODELS 9100, 9400, 9600, 5120 & 5140)

DIM "X"	TYPE OF ARM BEING USED	REFERENCE ILLUSTRATIONS
11 1/2"-13"	STRAIGHT / CURVED	FIG. 1.3

If adjustment of the trolley position is required, use the close travel adjustment screw located on the bottom of the opener, as shown in FIG. 1.4 on page 26. A 1/4 turn equals approximately 1" of trolley travel; turn clockwise to decrease distance (forward) and counter-clockwise to increase distance (forward).

NOTE: Proceed with "Connecting Door Arm To Door" Step 18, on page 14.

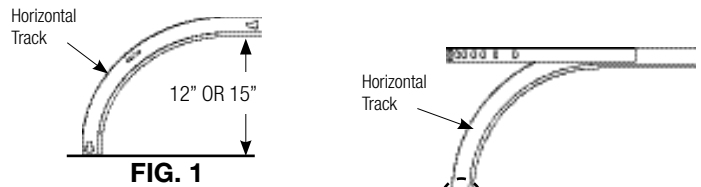
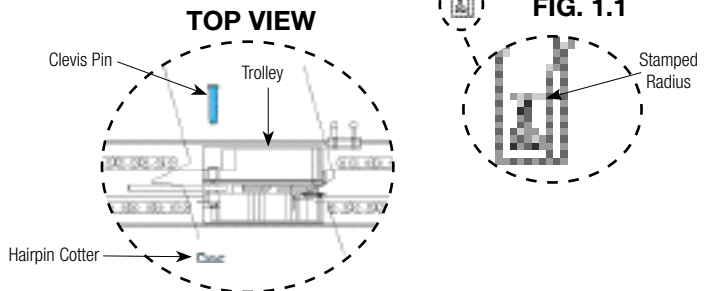

FIG. 1



TOP VIEW

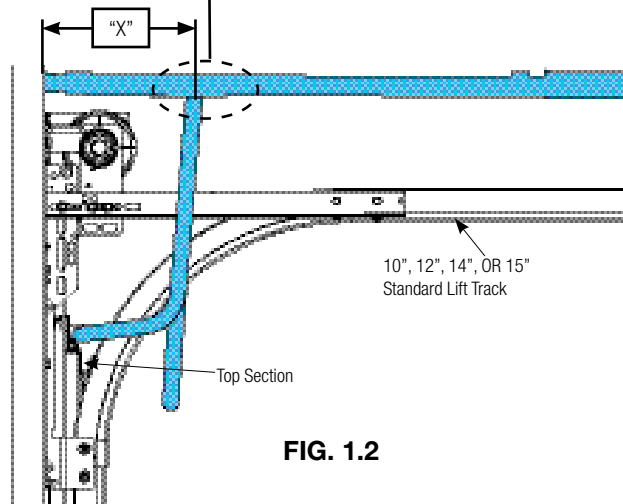

FIG. 1.2

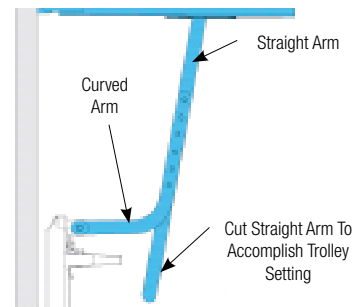

FIG. 1.3

STANDARD LIFT TROLLEY POSITIONING CHART FOR 14" AND 15" RADIUS (MODELS 9100, 9400, 9600, 5120 & 5140)

DIM "X"	TYPE OF ARM BEING USED	REFERENCE ILLUSTRATIONS
10"-12"	STRAIGHT / CURVED	FIG. 1.3

STANDARD LIFT TROLLEY POSITIONING CHART FOR (MODEL 9700) 15" RADIUS

DIM "X"	TYPE OF ARM BEING USED	REFERENCE ILLUSTRATIONS
11 1/16"-16 7/8"	STRAIGHT / CURVED	FIG. 1.3

Setting Trolley Close Position/ Connecting Door Arm (Continued)

LOW HEADROOM:
Using the **LOW HEADROOM TROLLEY POSITIONING CHART**, refer to **DIM "X"** to set the distance from header to trolley, as shown in FIG. 1.5.

NOTE: Depending on your setup, you may or may not have to cut straight arm to accomplish trolley settings.

If adjustment of the trolley position is required, use the close travel adjustment screw located on the bottom of the opener. A 1/4 turn equals approximately 1" of trolley travel; turn clockwise to decrease distance (forward) and counter-clockwise to increase distance (forward).

LOW HEADROOM TROLLEY POSITIONING CHART FOR (MODELS 9100, 9400, 9600, 5120 & 5140)		
DIM "X"	TYPE OF ARM BEING USED	REFERENCE ILLUSTRATIONS
20"	CURVED / STRAIGHT	FIG. 1.6
OPTIONAL HOOKUP		
10" - 14"	STRAIGHT	FIG. 1.6a

LOW HEADROOM TROLLEY POSITIONING CHART FOR (MODEL 9700)		
DIM "X"	TYPE OF ARM BEING USED	REFERENCE ILLUSTRATIONS
15"-18"	CURVED / STRAIGHT	FIG. 1.6
OPTIONAL HOOKUP		
10" - 14"	STRAIGHT	FIG. 1.6a

NOTE: Proceed with "Connecting Door Arm To Door" Step 18, on page 14.

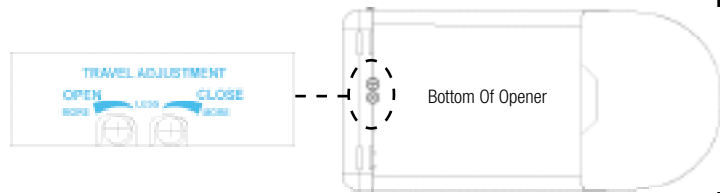

FIG. 1.4

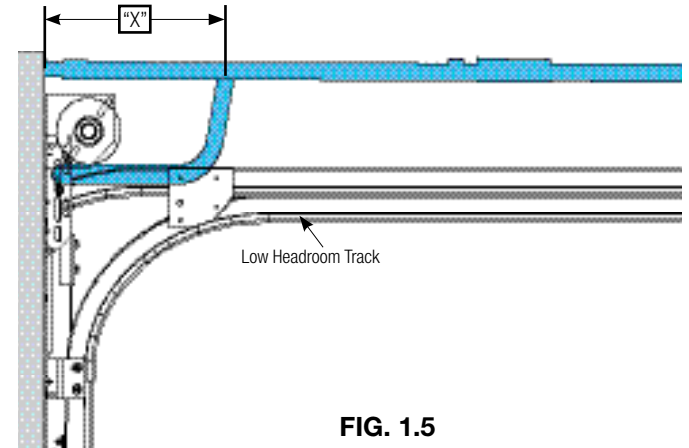

FIG. 1.5

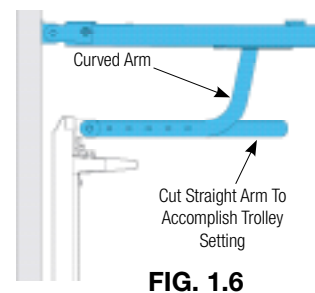

FIG. 1.6

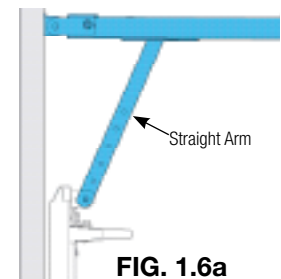

FIG. 1.6a



IMPORTANT SAFETY INSTRUCTIONS

WARNING

TO REDUCE THE RISK OF SEVERE INJURY OR DEATH:

- 1. READ AND FOLLOW ALL INSTRUCTIONS.**
- Never let children operate or play with the door controls. Keep remote controls away from children.
- Always keep a moving door in sight and keep people and objects away until it is completely closed. NO ONE SHOULD CROSS THE PATH OF A MOVING DOOR.
- NEVER GO UNDER A STOPPED, PARTIALLY OPEN DOOR.
- Test the Door/Opener monthly. The garage door MUST reverse on contact with a 1-1/2 inch high object (or a 2 x 4 board laid flat) on the floor. The door MUST also reverse when a 6" high object is placed on the floor in line with safety sensors. If Door/Opener fails these tests, have adjustments/repairs made immediately. Failure to make adjustments/repairs may cause severe or fatal injury.
- When possible, use the Emergency Disconnect only when the door is in the closed position. Be very cautious using the Emergency Disconnect when the door is open. Weak or broken spring(s) may allow the door to fall rapidly, causing a severe or fatal injury.
- KEEP THE GARAGE DOOR PROPERLY BALANCED. See the owner's manual included with the door. An improperly balanced door could cause a severe or fatal injury. Have a qualified service person make repairs to the cables, spring assemblies, and other hardware.

8. SAVE THESE INSTRUCTIONS.

Door activation:

Upon activation by either the wall station Up/Down button, transmitter or wireless keyless entry, the door will move in the following manner:

- If open, the door will close. If closed, the door will open.
- If closing, the door will stop. Next activation will open.
- If opening, the door will stop. Next activation will close.
- If an obstruction is contacted or the safety sensor beam is interrupted while closing, the door will reverse and the light will flash.
- If an obstruction is encountered while opening, the door will stop and the light will flash. The next activation will close the door.
- The Infrared Safety Sensor uses an invisible beam which, when broken by an obstruction, causes a closing door to reverse, prevents an open door from closing and causes the light to flash.

WARNING

ALWAYS KEEP MOVING DOOR IN SIGHT AND KEEP PEOPLE AND OBJECTS AWAY UNTIL IT IS COMPLETELY CLOSED. TO PREVENT A SEVERE OR FATAL INJURY, AVOID STANDING IN A OPEN DOOR WAY OR WALKING THROUGH THE DOORWAY WHILE THE DOOR IS MOVING.

WARNING

NEVER LET CHILDREN OPERATE DOOR OR PLAY WITH THE DOOR CONTROLS. KEEP REMOTE CONTROLS AWAY FROM CHILDREN. FATAL INJURY COULD RESULT SHOULD A CHILD BECOME TRAPPED BETWEEN THE DOOR AND FLOOR.

WARNING

KEEP THE GARAGE DOOR PROPERLY BALANCED. AN IMPROPERLY BALANCED DOOR COULD CAUSE SEVERE OR FATAL INJURY. HAVE A QUALIFIED SERVICE PERSON MAKE ADJUSTMENTS/REPAIRS TO CABLES, SPRING ASSEMBLIES, AND OTHER HARDWARE.

Emergency Disconnect:

WARNING

THE DOOR SHOULD BE FULLY CLOSED WHEN ACTIVATING THE EMERGENCY RELEASE DISCONNECT. WEAK OR BROKEN SPRINGS COULD ALLOW AN OPEN DOOR TO FALL RAPIDLY POSSIBLY CAUSING SEVERE OR FATAL INJURY.

The opener is equipped with an emergency release recessed trolley type disconnect system, enabling manual operation of the garage door during power failure. The trolley is disconnected from the chain by pulling down on the red release knob, allowing the garage door to be operated manually. Do not use the manual release knob to pull the door open or closed. The trolley will automatically reconnect when power is restored and door is activated. If emergency release is used, close door before operating opener.

NOTE: Outside keylock emergency releases are an available accessory and are recommended for garages without a service entrance.

HOW THE LIGHT WORKS AND WHAT IT MEANS WHEN IT FLASHES:

- Overhead light automatically turns on when opener is activated and remains on for 4 minutes for convenience and safety.
- The light will flash if opener senses an obstruction in the up or down direction, to warn you of a problem. It will continue flashing for 1 minute, and then shut off.

If the light begins to flash and the door moves a short distance and then reverses from a wall station button, transmitter or keyless entry, the external safety sensor device is activated or defective. To temporarily override safety sensor device and close door, activate wall station up/down button, keeping button depressed; opener will begin in down direction. The button must remain depressed until cycle is completed. If the button is released before cycle is completed, the door will reverse and come to full up position. Problems in the safety system should be corrected by a qualified service person.

NOTE: A fully open door with a blinking light indicates an obstruction or problems with external safety sensors during close travel. See trouble shooting section on page 35.



Operating the Wireless Wall Station

Up-Down Button:



Momentarily pressing the Up/Down button starts or stops door movement or changes door's direction. Pressing and holding Up/Down button during the door's travel will override safety sensors. The Up/Down Button (when unit is closed) can be activated by pressing flip cover.

WARNING

IF DOOR REQUIRES THAT SAFETY SENSORS BE OVERRIDDEN THAT CONDITION MUST BE CORRECTED IMMEDIATELY. FAILURE TO MAKE ADJUSTMENTS/REPAIRS COULD RESULT IN SEVERE OR FATAL INJURY.

Light Button:



Momentarily pressing the light button turns on the convenience light. The light will remain on until either the light button is pressed again or the door is activated. The light automatically turns on with a door activation and remains on for 4 minutes. Pressing the light button before the 4 minutes has elapsed will turn off the light. While the door is in motion, the light button functions identically as the Up/Down button, stopping or reversing the door immediately.

Timer Button:



Momentarily pressing the timer button causes a delayed activation of a stationary fully open door. The light fixture or the opener's lamp will blink on and off for about 10 seconds prior to closing the door, allowing enough time to exit the garage when the opener is in the timer mode. Pressing any button, except the program button while the opener lamp is blinking cancels the timer mode.

NOTE: The timer feature will only function with the door in the full open position. Pressing the timer button with a stationary door in any other position will cause the opener lamp to blink 4 times and the door will not be activated.

While the door is in motion, the timer button functions identical to the Up/Down button, stopping or reversing the door immediately.

Vacation Slide Switch:

The slide switch has two positions: Normal, and Door lock.

Normal position:



Move the slide switch to normal position for all normal functions of the opener. The normal position will cancel the door lock feature.

NOTE: When the slide switch is moved to the unlocked position the opener light fixture will blink on/off three times.

Door Lock position:



If the door is stopped (fully open, fully closed or partially open) move the slide switch to the door lock position to suspend all normal functions of the opener. The opener will remain completely disabled and non-operational in this mode. All wall stations, transmitters and keyless entry units are ignored until the slide switch is moved to the normal position. If the door is moving when the slide switch is moved to the door lock position, the door lock mode is not activated and all functions of the opener remain active.

NOTE: When the slide switch is moved to the locked position the opener light fixture will blink on/off three times.

Back Lit LED Lights:



The Up/Down arrows' backlit red LED blink intermittently to help you locate the wall station in a dark garage. This blink rate can be changed for longer battery life or can be turned off. The default blink rate is one blink every 2 seconds. For longer battery life the blink rate can be changed to blink once every 5 seconds. To change the blink rate, remove the battery cover and remove one battery. Re-install the battery and within 2 seconds, press the Light button. Re-install the battery cover.

For longest battery life, the blink can be turned off. To turn off the blink, remove the battery cover and remove one battery.

Re-install the battery and within 2 seconds, press the Pet button. Re-install the battery cover.

NOTE: The wall station's arrow LED will light while any wall station button remains pressed.

Pet Position:



Pressing the pet button opens a closed door to a preset position between 8 and 30 inches above the floor, allowing pets to enter and exit the garage without the door being fully open. The door must be fully closed to activate the pet open feature. Pressing the pet button with a stationary door in the pet open position will cause the door to close. Pressing the Up/Down button while the door is in the pet position will cause the door to open. While the door is in motion, the pet button functions identically to the Up/Down button, stopping or reversing the door immediately. The pet feature allows for custom setting of the pet position door height.

NOTE: A door in the "pet position" (open 8-30 inches) is not locked and should not be used as a secured door position.

Program Button:

The wall station program button has several functions.

- It can be used to set a custom pet position. (see Customizing the Settings, on the next page)
- It can be used to set the opener's closing force (see Adjustment #1 Page 32).

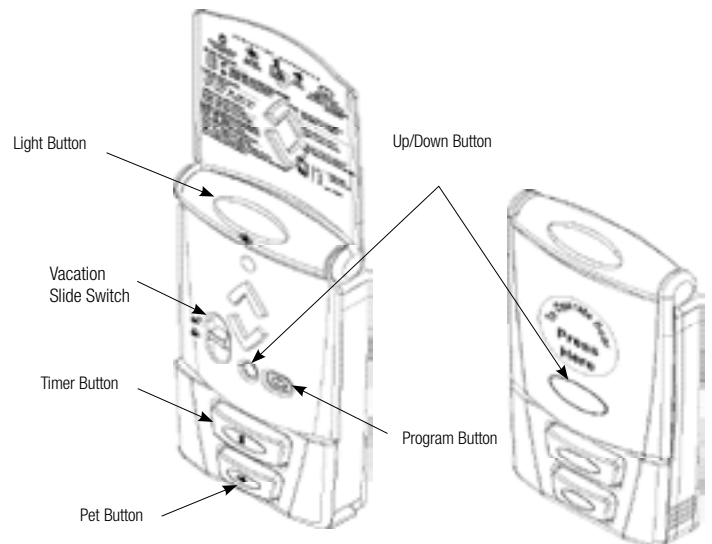



Customizing the Settings

Custom pet position:

The pet button opens a closed door to a preset position between 8 and 30 inches above the floor, allowing pets to enter and exit the garage without the door being fully open. To change the automatic pet opening height:

Start with the door in the closed position.

1. Operate the door then stop it at the desired height. If desired height is not achieved, the door must be returned to the closed position.
2. Press and release the wall stations program button, or the opener program switch button two times. The status light on the opener unit and the overhead light will flash on and off at a normal rate.
3. Press the pet button. The status light on the opener and the overhead light will flash on and off three times indicating successful programming.

Multi-Door Programming:

Momentarily pressing the button programmed in the transmitter programming step activates the door. Other buttons can also be programmed to activate different doors, for multi-door installations. Each button or a combination of two buttons pressed simultaneously can be programmed to activate a different door. Only one button at a time can be programmed to activate a specific opener. The transmitter LED will light while any transmitter button remains pressed.

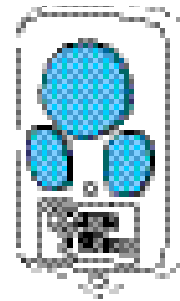
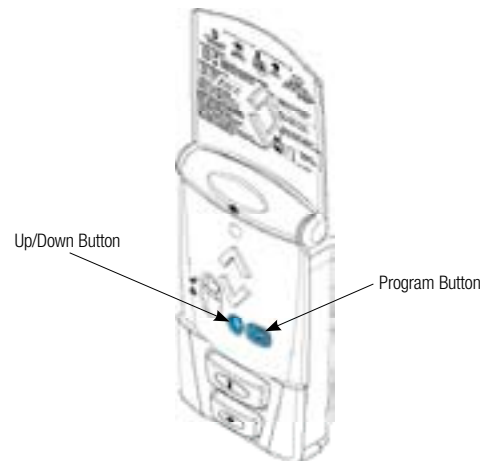

Opener Controls

The program button located on the right side of the opener has several functions.

1. Pressing the program button once, will make the status light and overhead lamp turn on steady. This mode allows programming of transmitters, wireless keyless entry, and wireless wall stations (see page 33).
2. Pressing the program button two times will make the status light and overhead lamp blink on and off. This mode allows programming of a custom pet position (see "Customizing The Settings" above).
3. Pressing the program button three times will make the status light and overhead lamp blink on and off with a long pause at each blink cycle. This mode allows programming of the opening force (see page 32).
4. Pressing and holding the program button for 10 seconds will erase all transmitters, multi-function wall station and wireless keyless entry from memory. The status light and overhead light will blink 3 times indicating a successful erase operation.

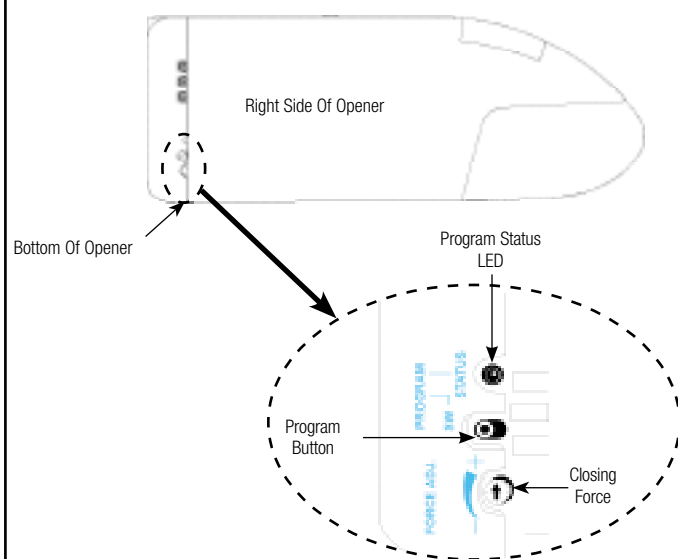



Primary Programming for HomeLink® to the Prodrive™

NOTE: This step can only be done on automobiles equipped with the HomeLink® System.

NOTE: Programming HomeLink® requires a Wayne-Dalton Transmitter that is programmed to the opener (the wallstation and transmitter(s) supplied with the opener, come pre-programmed from the factory). Any additional wallstation(s) or transmitter(s) will need to be programmed to the opener, see page 33.

IMPORTANT: Use the programming instructions provided with your vehicle first. Follow these instructions if the HomeLink® unit does not learn the transmitter, when using the vehicle's instructions.

NOTE: If Primary Programming does not work then use the Alternate Procedure on next page.

NOTE: Vehicle may need to be in accessory position when programming. Check car owner's manual.

NOTE: HomeLink® is a registered trademark of Johnson Controls.

Programming/Training HomeLink® Unit

WARNING

GARAGE DOOR MAY OPERATE DURING PROGRAMMING. TO AVOID POSSIBLE SEVERE OR FATAL INJURY, PLACE THE EMERGENCY DISCONNECT HANDLE IN THE MANUAL OPERATED POSITION.

1. Pull the manual disconnect to put the opener in the disengaged position.
2. Verify the HomeLink® unit has an empty channel press the desired HomeLink® button and observe the indicator light if it flashes slowly, the channel is empty and ready for programming. If pressing the desired channel/button causes the indicator light to blink rapidly, or come on without blinking this channel is already programmed. You either need to choose a different channel/button on the HomeLink®, or perform Step 3 below.
3. **OPTIONAL** – To completely clear all channels on the HomeLink® unit, press and hold the two outside buttons on the HomeLink® unit until the HomeLink® indicator light begins to flash rapidly (approx. 20 seconds), then release both buttons. (Do not perform this step to train additional hand-held transmitters.) **NOTE:** This operation erases all previously learned transmitters and you will need to re-teach any other transmitters to your HomeLink® unit.
4. Hold the end of the Wayne-Dalton hand-held transmitter approximately 1 to 3 inches away from the HomeLink® surface keeping the HomeLink® indicator light in view.
5. Press and hold the desired HomeLink® channel/button indicator light should flash slowly (indicating empty channel). Continue holding the HomeLink® button, and press and hold the large button (“U” Models) or desired button (“A”, “C” or “R” models) on the Wayne-Dalton transmitter for approximately 3-5 seconds. The HomeLink® indicator light should now blink rapidly, indicating a successful learn operation. Release both buttons. Verify transmitter has been learned by pressing the HomeLink® button used to learn the transmitter; HomeLink® indicator light will come on without flashing or flash rapidly indicating a successful learn. Proceed to step 6 below. **NOTE:** If this procedure is unsuccessful perform Alternate procedure.

Teaching HomeLink® to the opener

6. Press and release the program switch on the opener. The red program status light on the opener and light will turn on and remain lit for one minute, indicating that it is ready to learn.
7. Press the HomeLink® button used in Step 5 above for 1 to 3 seconds. The program status light and convenience light on the opener will turn on and off three times indicating a successful learn.
8. Press the HomeLink® button once more to operate the door. The opener will activate and the trolley will travel towards open, the next activation will cause the trolley to travel to the closed position and reengage, subsequent operations will move the door.



Alternate Programming for HomeLink® to the Prodrive™

NOTE: This Step can only be done on automobiles equipped with the HomeLink® System.

NOTE: Programming HomeLink® requires a Wayne-Dalton Transmitter that is programmed to the opener (the wallstation and transmitter(s) supplied with the opener, come pre-programmed from the factory). Any additional wallstation(s) or transmitter(s) will need to be programmed to the opener, see page 33.

IMPORTANT: Use the programming instructions provided with your vehicle first. Follow these instructions if the HomeLink® unit does not learn the transmitter, when using the vehicle's instructions.

NOTE: Vehicle may need to be in accessory position when programming. Check car owner's manual.

NOTE: HomeLink® is a registered trademark of Johnson Controls.

Programming/Training HomeLink® Unit

WARNING

GARAGE DOOR MAY OPERATE DURING PROGRAMMING. TO AVOID POSSIBLE SEVERE OR FATAL INJURY, PLACE THE EMERGENCY DISCONNECT HANDLE IN THE MANUAL OPERATED POSITION.

1. Pull the manual disconnect to put the opener in the disengaged position.
2. Press and hold the two outside buttons on the HomeLink® unit until the HomeLink® indicator light begins to flash rapidly (approx. 20 seconds), then release both buttons. (Do not perform this step to train additional hand-held transmitters.) **NOTE:** This operation erases all previously learned transmitters and that you need to re-teach any other transmitters to your HomeLink® unit by repeating steps 3 - 6 below.
3. Hold the end of the Wayne-Dalton hand-held transmitter approximately 1 to 3 inches away from the HomeLink® surface keeping the HomeLink® indicator light in view.
4. Press and hold the Wayne-Dalton hand-held transmitter's large center button. The transmitter's red indicator light will turn on. After 10 seconds the red indicator light will blink rapidly. Do not release the button and proceed to the next step.
5. Press the desired HomeLink® button. Do not release either button until step 6 has been completed. **NOTE:** It is important to immediately press the HomeLink® button as soon as the transmitter's red indicator light blinks. If the red indicator light subsequently turns on or off ignore it, this is normal.
6. The HomeLink® indicator light will be blinking during the training operation. When the HomeLink® indicator light flashes rapidly or turns off (approx. 5 to 60 seconds), both buttons may be released. The HomeLink® indicator light flashing rapidly or turning off indicates successful programming of the new frequency signal. Verify transmitter has been learned by pressing the HomeLink® button used to learn the transmitter; HomeLink® indicator light will come on without flashing or flash rapidly indicating a successful learn.

Teaching HomeLink® to the opener

7. Press the program switch on the opener. The red program status light on the opener and light will turn on and remain lit for one minute, indicating that it is ready to learn.
8. Press the HomeLink® button used in Step 5 above for 1 to 3 seconds. The program status light on the opener will turn on and off three times indicating a successful learn.
9. Press the HomeLink® the opener will activate and the trolley will travel towards open, the next activation will cause the trolley to travel to the closed position and reengage, subsequent operations will move the door.



Adjustments

Adjustment # 1 Opening and Closing Force

This garage door opener is built with a safety system that allows the door to reverse when closing and stop when opening. This must be adjusted so your opener does not use excessive force in the down direction or react to the weight of the door during upward travel.

CLOSING FORCE ADJUSTMENT

To help determine that the closing door force is not excessive, grasp the door handle or bottom edge during downward travel. The opener should REVERSE to this force.

NOTE: Do not stand under door during this test.

To adjust the closing force follow one of the two methods listed below.

Method A (manual)

1. Turn the FORCE ADJ. counter clockwise to decrease force and reversal test until door reacts properly.

Method B (computer assisted)

1. Operate the door to the fully open position.
2. Turn the FORCE ADJ. counter clockwise to the minimal force setting.
3. Press the PROGRAM button two times or the PROGRAM button on the Wireless Wall Station (if included) until the LED turns on solid (5 sec.). The STATUS LED and the overhead lamp will flash on and off at a slow rate.
4. Operate the door to the fully closed position.
5. Turn the FORCE ADJ. clockwise until the STATUS LED flickers or just turns off.
6. Press the PROGRAM button once to confirm setting.

OPENING FORCE ADJUSTMENT

To determine that the opening force is not excessive, grasp the door handle or bottom edge during upward travel. If the opener does not stop or is hard to hold, decrease the open force setting. The opener should STOP without using excessive force.

To change the opening force follow the procedure listed below.

1. Operate the door to the fully closed position.
2. Press the PROGRAM button three times. The STATUS LED and the overhead lamp will flash on and off. The blink rate, which corresponds to the force setting, will consist of 1 to 5 fast blinks followed with a long pause between blink sequences.
3. The first time an attempt is made to increase the force, the setting will begin at the lightest setting (1 blink).
4. To increase the force, press and release the door up/down button on any control (The STATUS LED will remain lit during button press).
5. Continue to press and release the door button until the desired force setting is achieved.
6. Press the PROGRAM button once to confirm setting.

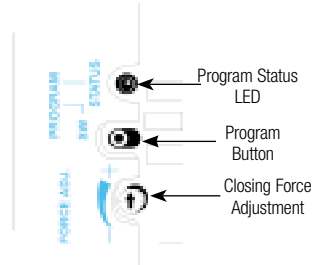

repeat

Adjustment # 2 Contact Obstruction Sensing (Closing Direction)

The opener is designed to automatically reverse the door during closing travel whenever it comes in contact with a 2 x 4 laid flat on the floor. An object on the floor with a height less than 1-1/2" will not cause the door to reverse. (Test according to instructions in Step 21.)

If opener reverses properly with a 2 x 4 laid flat on the garage floor (Step 21) and stops without the solid test object in the fully closed position, proceed to Adjustment # 3.

When door comes in contact with a 2 x 4 laid flat on the garage floor and stops instead of reversing, reset the door close limits according to instruction in Step 19, adjusting until door reverses upon contact with a 2 x 4 laid flat on the garage floor.

If door reverses when it comes in contact with the floor, reset the door close limits according to instruction in Step 19.

Adjustment # 3 Positive Mechanical Door Lock

The garage door opener is designed with an automatic mechanical locking system. This lock secures the door in the fully closed position.

To adjust, activate the door opener and allow the door to go to its fully closed position. Loosen the two screws on the rail stop and move it behind the latch assembly with a gap of 3/4" between "stop" and "latch". Retighten screws.

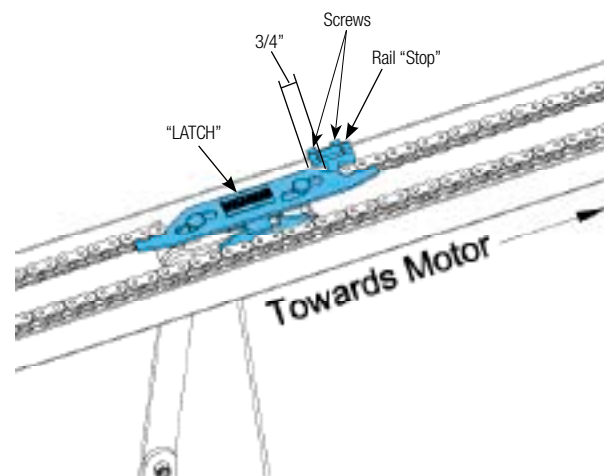



Programming Wireless Wall Station(s) Or Transmitter(s) to Opener

Tools Needed:

None

WARNING

DURING PROGRAMMING THE GARAGE DOOR MAY OPERATE. KEEP PEOPLE AND OBJECTS CLEAR OF THE MOVING DOOR TO PREVENT DOOR DAMAGE OR POSSIBLE PERSONAL INJURY.

NOTE: Programming failure can occur if the wall station or transmitter is too close to the opener during the programming sequence. There must be a minimum of 6 feet between the wall station/transmitter and the opener.

NOTE: The opener can be activated by up to 8 remote transmitters, 2 wall stations and 2 keyless entries. If a 9th remote is programmed the first remote programmed will be lost from memory. The same is true if a third wall station or a third keyless entry is programmed, the first will no longer be in memory and will not operate the opener.

NOTE: Do not press any button on the wall station or transmitter until instructed.

TRANSMITTER:

1. Press and release the PROGRAM button located on the garage door opener. The red PROGRAM STATUS light on the opener unit and the overhead lamp will turn on and remain lit for one minute, indicating activation of the learn mode.

2. Press one of the buttons on the transmitter you wish to use to operate the door. The PROGRAM STATUS light on the opener will turn on and off three times indicating a successful learn.

3. Press the same button on the transmitter once more to confirm operation. The opener will turn on and move the door.

At this point you will be able to activate the opener.

WALL STATION:

1. Press and release the PROGRAM button located on the garage door opener. The red PROGRAM STATUS light on the opener unit and the overhead lamp will turn on and remain lit for one minute, indicating activation of the learn mode.

2. Press the light on/off button on the wall station. The program status light will turn on and off three times indicating a successful learn.

3. Press the light on/off button on the wall station once more to confirm operation. The overhead light will toggle from on to off and from off to on. At this point you will be able to activate the opener.

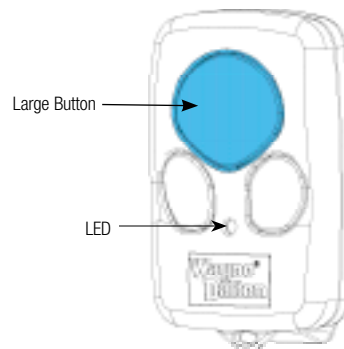
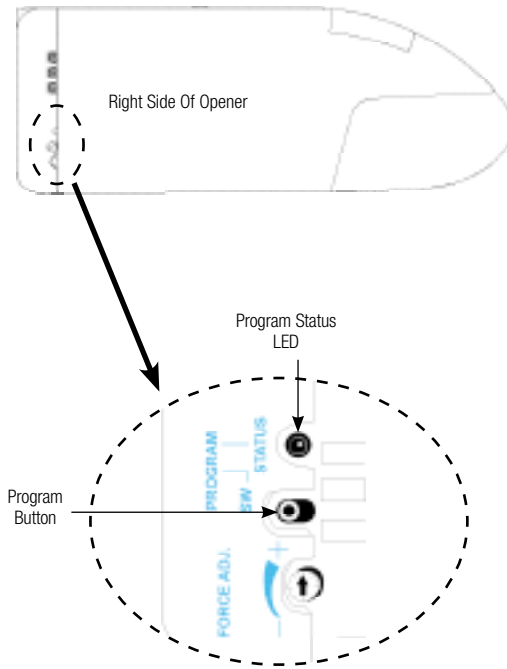

Transmitter



Wall Station



Maintenance

Monthly Maintenance:

1. Lubricate hinges and rollers of garage door.
2. Inspect the door for loose fasteners, worn or frayed counterbalance cables and the presences of legible safety labels/ tags. Have repairs made by a qualified service person. Contact customer assistance for free replacement safety labels/ tags.
3. With door fully closed, pull down on the emergency disconnect to manually operate the door. If the door feels unbalanced or binds, have a qualified service person make necessary adjustments or repairs to the door.
4. Perform the contact/obstruction tests. See Steps 21 and 22 for the contact/obstruction test instructions. If door/opener fails contact/obstruction test reset the door close limits according to the instructions in Step 19, adjusting until door reverse on contact with a 2 x 4 board laid flat on the garage floor. If opener still fails, have a qualified service person make adjustments/repairs or this could result in severe or fatal injury.
5. Failure of door/opener to respond to transmitter, multi-function wall station or wireless keyless entry may be due to a weak or dead battery. Press and hold the activation button on either the transmitter or the wall station. If the LED does not light, this is an indication that the battery is weak or dead. Replace the battery.

Twice a Year:

Check chain tension. If chain rests on bottom of rail, adjust tension by turning the two chain adjusting nuts at the end of the rails (opposite the opener end) clockwise. Make sure to adjust both nuts equal amounts and until chain is approximately 1/2" above the bottom of rails when measured in the middle of the rails.

Battery Replacement for Wall Station:

Remove the battery cover completely (right-hand side of wall station) by disengaging the battery cover's lower clip; remove the old batteries. Install two AAA batteries into the wall station observing the polarity, (+) and (-), of both batteries. After a few seconds, the up/down red LED will begin to blink every two seconds. If it is desired to slow the LED blink rate refer to the wall station operation section on page 28 "Backlit LED Lights". Re-install the battery cover by first inserting its top into the wall station then inserting and securing its bottom.

Note: Use only two AAA batteries.

Note: Dispose of dead batteries properly.

Battery Replacement for Transmitter:

Insert a coin in the coin slot of the transmitter and twist coin to access the dead battery. Replace the batteries, being careful to match the positive (+) symbols on the circuit boards with the battery; snap case back together.

Note: Transmitters use two CR2016 or equivalent batteries.

Note: Dispose of dead batteries properly.

Battery Replacement for Wireless Keyless Entry:

To change batteries, snap open case with a coin and remove old batteries. Replace the batteries, being careful to match the positive (+) symbols on the circuit boards with the battery; snap case back together.

Note: Keyless entries use two CR2032 or equivalent batteries.

Note: Dispose of dead batteries properly.



Troubleshooting

SYMPTOM	PROBABLE CAUSE	CORRECTIVE ACTION
Opener won't work from wall button or radio control.	No power to opener. Short circuit in wires to opener or wall button. Motor Protector trips open due to excessive use.	Check cord to outlet, wall switch and circuit breaker. Isolate by disconnecting the wires at the opener from the wall station. Allow motor to cool for 20 minutes and try again.
Opener works from wall button but not from radio control.	Radio control system non-operational.	Weak or dead battery in transmitter replace. Security code not matched between receiver and transmitter (see page 33) If two or more transmitters don't work, have motor control board tested.
Door does not open and opener light flashes.	Something obstructing door travel. Insufficient opening force. Build up of ice and snow around door.	Disconnect door from operator. Operate door by hand to locate obstruction or call a service person. Adjust opening force. (See Adj. #1 on page 32). Shovel and clear door area.
Door does not open fully and light does not flash.	Open limit not set properly.	Adjust open travel with screwdriver, turn counter-clockwise to desired setting. 1/4 turn equals 1" of travel (see Step 20).
Door stops and does not close fully.	Close limit not set properly.	Adjust close travel with screwdriver, turn clockwise to desired setting. 1/4 turn equals 1" of travel (See Step 19).
Door closes and then returns to fully open position and opener light flashes.	Door arm adjustment. Close travel adjustment is set beyond normal door position. Obstructions on floor.	Adjust door arm (See Step 17 and 18). Adjust close travel with screwdriver, turn counter-clockwise to desired setting. 1/4 turn equals 1" of travel (See Step 19). Check for stones or ice under door and remove.
When activated with door in fully open position, door travels for 1 second, stops, and returns to fully open position and light begins to flash.	Infrared safety sensors out of adjustment or defective. Obstructions in door opening.	Infrared safety sensors alignment should be checked per instructions. (See Step 16). Check for object blocking Infrared safety sensors.
Door reverses travel before reaching fully closed position and opener light flashes.	Activation of obstruction sensing system. Loose or hanging objects on door activating Infrared safety sensor. Insufficient closing force.	Check for binding in door travel (door "stops", door tracks, etc). Remove objects. Adjust closing force. (See Adj. #1 on page 32).
Door fully opens and then light flashes.	Open limit is set too high and trolley is hitting the stop bolt.	Adjust open travel with screwdriver, turn clockwise to desired setting. 1/4 turn equals 1" of travel (see Step 20).

Parts Breakdown Rail Assembly - All Models

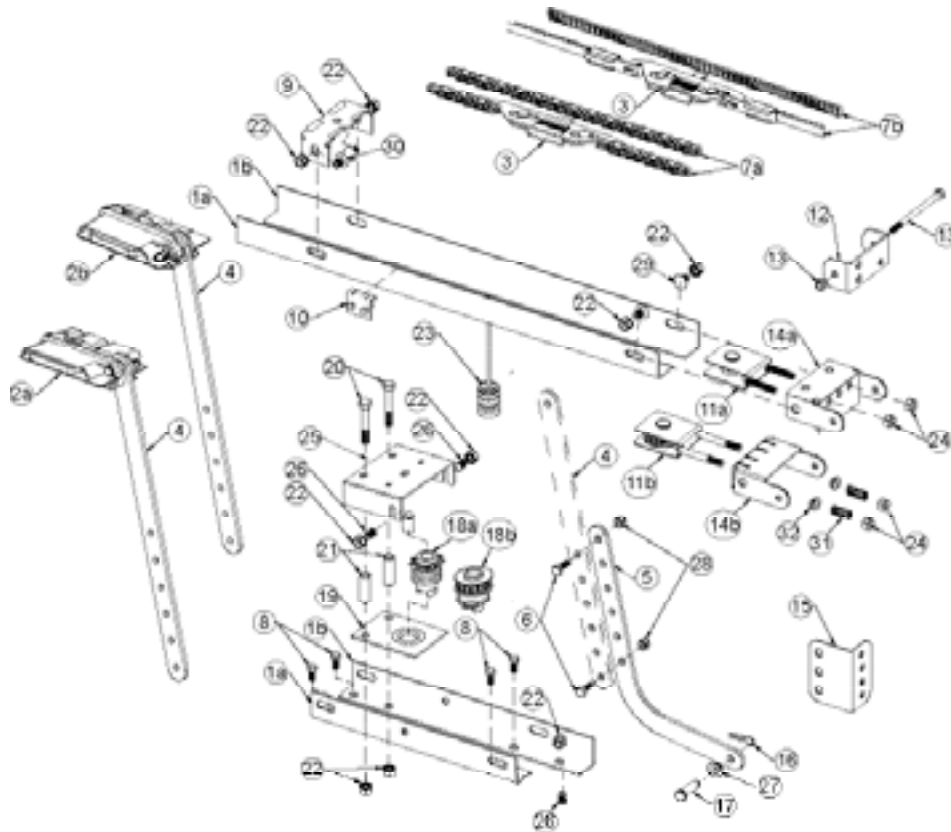

#.	Part #	Description	# Per Unit	#.	Part #	Description	# Per Unit
1a.	325756	R.H. Rail (7')	1	12.	220959	Front Wall Bracket	1
	325758	R.H. Rail (8')	1	13.	157559	1/4" - 20 x 4" Hex Head Bolt w/ Lock Nut	1
	325760	R.H. Rail (10')	1	14a.	220958	Front Bracket - Chain	1
1b.	325753	L.H. Rail (7')	1	14b.	320696	Front Bracket - Belt	1
	325757	L.H. Rail (8')	1	15.	220956	Door Bracket	1
	325759	L.H. Rail (10')	1	16.	326207	Hairpin Cotter	1
2a.	324527	Trolley Assembly - Chain	1	17.	326206	5/16" x 1-1/4" Multi-Grip Clevis Pin	1
2b.	320697	Trolley Assembly - Belt	1	18a.	325022	Sprocket Coupling w/ Bushing - Chain	1
3.	309960	Chain Latch Assembly	1	18b.	325687	Sprocket Coupling w/ Bushing - Belt	1
4.	324273	Door Arm (Upper)	1	19.	252106	Sprocket Base Assembly	1
5.	324272	Door Arm (Lower)	1	20.	251228	5/16" - 18 x 2" Hex Bolts	2
6.	308967	1/4" - 20 x 3/4" Machine Bolt	2	21.	221014	Spacer Tubes	2
7a.	325682	Chain, 7'	1	22.	220999	5/16" - 18 KEP Nut	As Req.
	325683	Chain, 8'	1	23.	157143	Red Release Knob	1
	325684	Chain, 10'	1	24.	157665	Adjusting Nuts	2
7b.	325685	Belt, 7'	1	25.	324270	Sprocket Cap Assembly	1
	325686	Belt, 8'	1	26.	157600	5/16" - 18 x 1/2" Self Clinching Bolt	3
	325572	Belt, 10'	1	27.	324200	Nylon Shoulder Bushings	1
8.	157510	Motor Head Mounting Screw 1/4" - 20 x 5/8"	4	28.	157561	Locking Nuts	2
9.	220960	Rail Spacer Bracket	3 or 4	29.	157602	5/16" - 18 x 1/2" Carriage Bolts	As Req.
10.	294674	Rail Stop w/ Set Screw	1	30.	309907	5/16" - 18 x 1/2" Flathead Carriage Bolts	As Req.
11a.	318113	Chain Idler Assembly	1	31.	320693	Tension Springs - Belt	2
11b.	320704	Belt Idler Assembly	1	32.	324200	Nylon Shoulder Bushing - Belt	2

Parts Breakdown Opener Assembly And Accessories - All Models

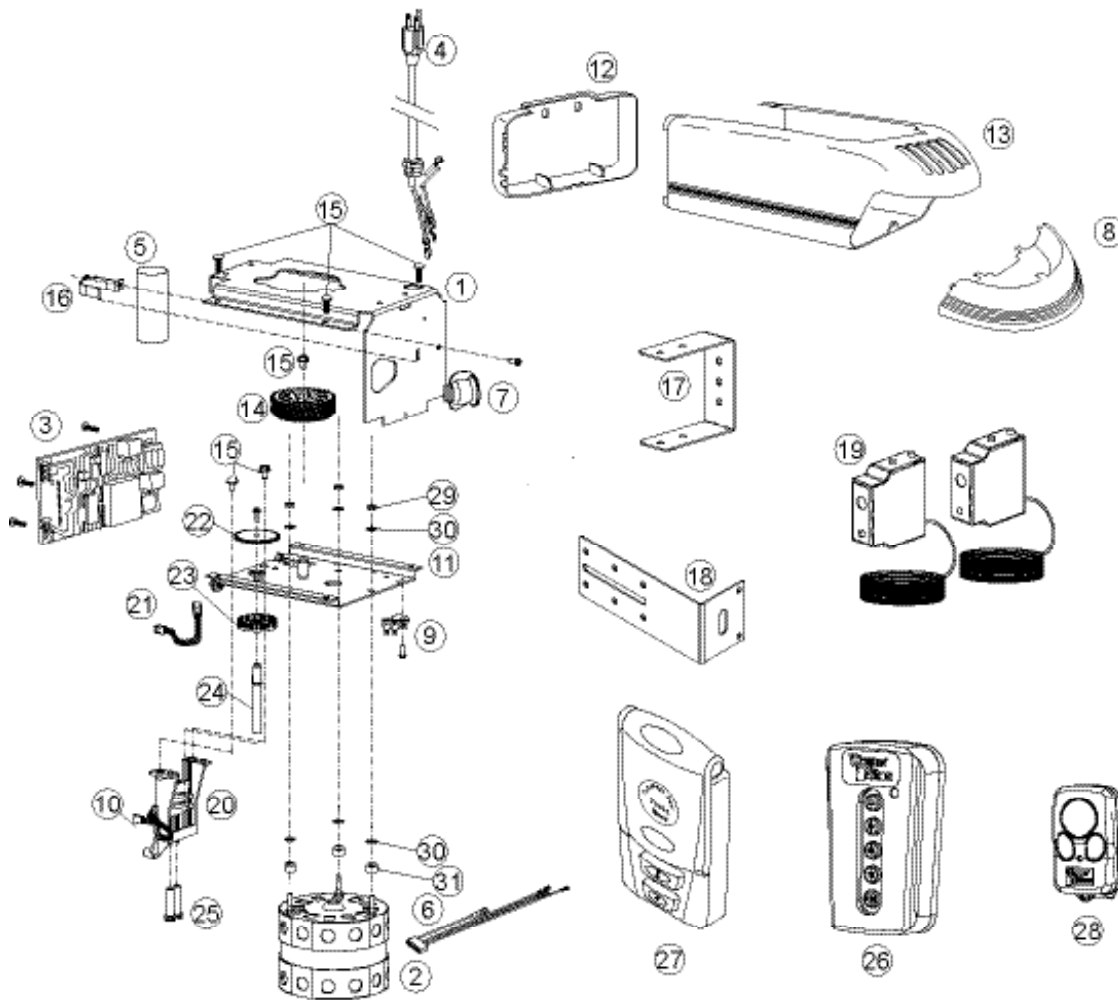

#.	Part #	Description	# Per Unit	#.	Part #	Description	# Per Unit
1.	157167	Frame	1	16.	301675	Capacitor Clamp	1
2.	325017	Motor 1/2 HP	1	17.	157166	Wired Sensor Mounting Bracket	2
3.	306131	Motor Control Board	1	18.	157165	Wired Sensor Sliding Bracket	2
4.	306364	Power Supply Cord	1	19.	318873	Infrared Safety Sensors - Pair	1
5.	260570	Capacitor 1/2 H.P.	1	20.	252092	Limit Assembly (Includes Items #10, 26 & 27)	1
6.	306486	Wiring Harness	1	21.	249321	LED Interrupter	1
7.	269028	Light Socket	1	22.	260556	Limit Driver Gear	1
8.	260552	Lens	1	23.	157039	Interrupter Disk	1
9.	252994	MOV Surge Suppressor	1	24.	260557	Shaft, Limit Driver	1
10.	252993	Limit Switch	1	25.	157055	Limit Adjuster	2
11.	325567	Sub-Frame	1	26.	306134	5 Button Wireless Keyless Entry	1
12.	325067	End Cap (Blue)	1	27.	311365	Wireless Multi Function Wall station	1
	325093	End Cap (Black)	1	28.	312962	3 Button Mini Transmitter	1 or 2
13.	325066	Housing (Blue)	1	29.	157666	Hex Nut #10-32	3
	325092	Housing (Black)	1	30.	157585	Lock Washer # 10	6
14.	325020	Gear Driven	1	31.	157496	Nylon Motor Spacer	3
15.	251248	Screw 1/4"-20x3/8"	7				

Prodrive™ Accessories

Three Button Mini / Visor Transmitter



Controls up to 6 doors or wireless accessories. Includes visor clip.

Wired Deluxe Wall Station



Allows independent door up/down control and overhead light on/off control.

Wireless Multi-Function RF Wallstation



Completely wireless unit with independent door up/down control, light on/off control, custom pet opening, delay exit timer, and program button.

Wireless Keyless Entry



10 digit numeric keypad which allows the operation of the garage door opener from outside by entering a programmable personal code on a keypad. Can be programmed to hundreds of doors.



5 digit numeric keypad which allows the operation of the garage door opener from outside by entering a programmable personal code on a keypad. Can be programmed to hundreds of doors.

Key Cable Outside Disconnect



Recommended for all vault type garages without an access door

Outside Key Switch

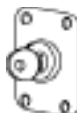

Used to open the door automatically from outside the garage whenever the remote control is not available. Shipped with 2 keys.

Wire Spool



80ft. 22 gauge, 2 conductor polarized. UL listed (CL-2, 75deg. C.).

Wired Infrared Safety Sensors



Reversing sensors communicate with door opener via direct wire connections to detect obstructions in path of door and reacts by reversing door.



Cut-Out Template to Aid Installation

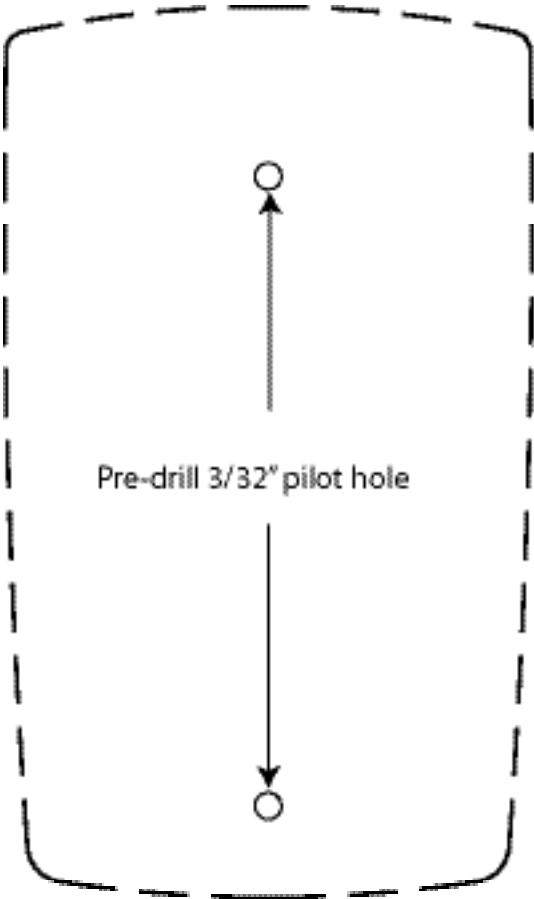

Multifunction
Wall Station Template

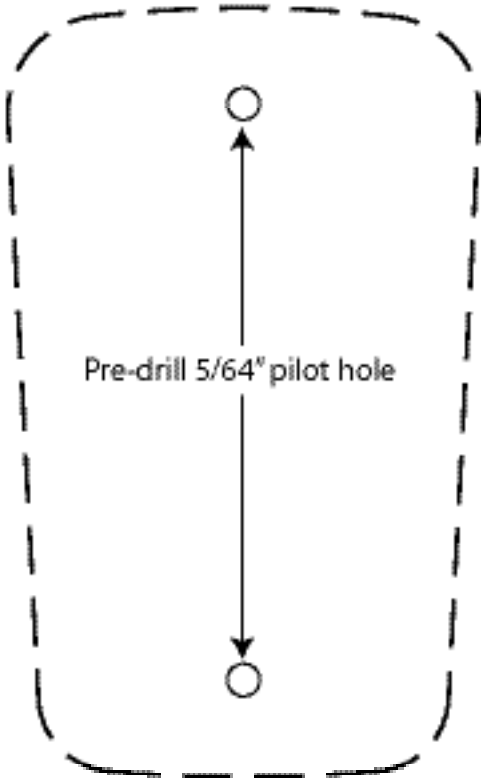

5 Button
Keyless Entry Template

Please Do Not Return This Product To The Store

Call Us Directly! Our Trained Technicians Will Answer
Your Questions and /or Ship Any Parts You May Need

**Call Us Toll-Free:
(888) 827-3667**

Thank you for your purchase

www.wayne-dalton.com



LIFETIME LIMITED WARRANTY

The Manufacturer warrants that the Prodrive™ Garage Door Opener's electronic and mechanical components (excluding motor) will be free from defects in materials and workmanship for a period of **ONE YEAR** (Models 3220C, 3221C, 3222C, 3320B, 3322B) and **FIVE YEARS** (Models 3224C, 3324B) from the date of installation, provided it is properly installed, maintained and cared for under specified use and service.

The Motor is warranted for **FIVE YEARS** (Models 3220C, 3221C, 3320B) and for **LIFETIME** (Models 3222C, 3224C, 3322B, 3324B) against defects in materials and workmanship. Batteries are not warranted.

This Limited Warranty extends to the original homeowner, providing the Prodrive™ Garage Door Opener is installed in his/her place of primary residence. This Limited Warranty is not transferable. The Limited Warranty applies to residential property only.

NO EMPLOYEE, DISTRIBUTOR, OR REPRESENTATIVE IS AUTHORIZED TO CHANGE THE FOREGOING LIMITED WARRANTY IN ANY WAY OR GRANT ANY OTHER WARRANTY ON BEHALF OF MANUFACTURER.

The Manufacturer shall not be responsible for any damage resulting to or caused by its products by reason of installation, improper storage, unauthorized service, alteration of products, neglect or abuse, any acts of nature beyond Manufacturer's control (such as, but not limited to, lightning, power surges, water damage, etc.), or attempt to use the products for other than the customary usage or for their intended purposes. The above Limited Warranty does not cover normal wear or any damage beyond Manufacturer's control. This Limited Warranty does not cover field replacement labor.

THIS LIMITED WARRANTY COVERS A CONSUMER PRODUCT AS DEFINED BY THE MAGNUSON-MOSS WARRANTY ACT. NO WARRANTIES, EXPRESSED OR IMPLIED, (INCLUDING, BUT NOT LIMITED TO, THE WARRANTY OF MERCHANTABILITY OR FITNESS FOR A PARTICULAR PURPOSE), SHALL EXTEND BEYOND THE APPLICABLE TIME PERIOD STATED IN BOLD FACE TYPE ABOVE.

Claims for defects in material and workmanship covered by this Limited Warranty shall be made in writing, within the warranty period, to the dealer from whom the product was purchased. Manufacturer may either send a service representative or have the product returned to the Manufacturer at Buyer's expense for inspection. If judged by Manufacturer to be defective in material or workmanship, the product will be replaced or repaired at the option of the Manufacturer, free from all charges except authorized transportation and replacement labor. Replacement unit may be an equivalent model that has been factory refurbished. Remainder of original Limited Warranty period will apply to repair/replacement unit.

THE REMEDIES OF BUYER SET FORTH HEREIN ARE EXCLUSIVE AND ARE IN LIEU OF ALL OTHER REMEDIES, THE LIABILITY OF MANUFACTURER, WHETHER IN CONTACT, TORT, UNDER ANY WARRANTY OR OTHERWISE, SHALL NOT EXTEND BEYOND ITS OBLIGATION TO REPAIR OR REPLACE, AT ITS OPTION, ANY PRODUCT OR PART FOUND BY MANUFACTURER TO BE DEFECTIVE IN MATERIAL OR WORK SHALL NOT BE RESPONSIBLE FOR ANY DIRECT, INDIRECT, SPECIAL OR CONSEQUENTIAL DAMAGES OF ANY NATURE.

This Limited Warranty gives you specific legal rights and you may have other rights, which may vary from state to state. However, some states do not allow limitation on how long an implied warranty lasts or the exclusion or limitation of incidental or consequential damages so the above limitations or exclusions may not apply to you.

Patent Information

Models: 3220C, 3221C, 3222C, 3224C, 3320B, 3322B, 3324B, 3220C-Z, 3221C-Z, 3222C-Z, 3224C-Z, 3320B-Z, 3322B-Z, 3324B-Z

Covered by one or more of the following U.S. patents: D413,055; D413,579; D413,867; D421,031; D472,568; D472,910; D473,573; D473,574; D505,393; 5,929,580; 5,931,212; 6,078,249; 6,145,570; 6,161,438; 6,164,014; 6,325,134; 6,326,751; 6,326,754; 6,401,792; 6,561,255; 6,561,256; 6,568,454; 6,588,156; 6,605,910; 6,667,591; 6,739,372; 6,845,804; 6,851,465; 6,873,127; 6,880,609; 6,897,630; 6,903,650; **Other U.S. and foreign patents pending.**

FCC and IC Statement

FCC Regulatory Information:

This device complies with Part 15 of the FCC Rules. Operation is subject to the following two conditions: (1) this device may not cause harmful interference, and (2) this device must accept any interference received, including interference that may cause undesired operation.

IC Regulatory Information:

This Class B digital apparatus meets all requirements of the Canadian Interference Causing Equipment Regulations. Operation is subject to the following two conditions: (1) this device may not cause harmful interference, and (2) this device must accept any interference received, including interference that may cause undesired operation.

NOTE: This equipment has been tested and found to comply with the limits for a Class B digital device, pursuant to Part 15 of the FCC Rules. These limits are designed to provide reasonable protection against harmful interference in a residential installation. This equipment generates, uses, and can radiate radio frequency energy and, if not installed and used in accordance with the instructions, may cause harmful interference to radio communications. However, there is no guarantee that interference will not occur in a particular installation. If this equipment does cause harmful interference to radio or television reception, which can be determined by turning the equipment off and on, the user is encouraged to try to correct the interference by one or more of the following measures: Reorient or relocate the receiving antenna. Increase the separation between the equipment and receiver. Connect the equipment into an outlet on a circuit different from that to which the receiver is connected. Consult the dealer or an experienced radio/TV technician for help.

WARNING: Changes or modifications to this unit not expressly approved by party responsible for compliance could void user's authority to operate this equipment.

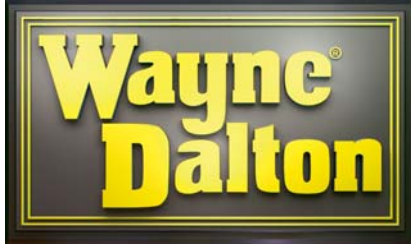

Z-Wave™ enabled prodrive™



This product is compatible with other Z-Wave™ enabled products

Thank you for purchasing the Z-Wave™ enabled prodrive™. The Z-Wave™ enabled prodrive™ by Wayne-Dalton allows you to control your home by remote control. You can create a complete Home Control and Access Network by combining your Z-Wave™ enabled prodrive™ with the complete line of Wayne-Dalton's HomeSettings products.

Endless Possibilities

HomeSettings products will allow you to easily control multiple devices in a home with the push of a button in what is known as a "scene". Turning on all of the lights as you come home is an example of a scene. Dimming lights and closing your curtains to watch TV, it's also a scene.

Install. Setup. Match. Go!

Creating a home control network is easy. Install the modules you need to control lights, temperature, and access. Setup your scenes with a portable controller then copy them to your prodrive garage door opener. Finish by matching a keychain remote control button to a scene. Once you install your modules, a simple scene consisting of turning on your garage and outside lights can be setup in less than 30 minutes.

Smart Technology

A Z-Wave™ network is a collection of modules in a mesh network. Each module acts as a sender and a receiver using radio waves to communicate. In addition, thanks to the mesh technology each module in the network is able to relay messages to other modules thus increasing the reliability of the network. The more devices you add the better the network gets. Up to 232 devices can be part of a network. All Wayne-Dalton HomeSettings products are Z-Wave™ enabled.

Wayne-Dalton.com/access

Visit www.wayne-dalton.com/access to learn more about Wayne-Dalton's HomeSettings line of home control products.

Install. Setup. Match. Go!



Install

Install your HomeSettings modules to control your lights, appliances, etc. Get ideas at www.wayne-dalton.com/access.



Install your prodrive garage door opener as outlined in the installation and owners manual.

Setup Scenes with a portable controller



Then.. Copy to prodrive

Setup

Use a portable controller to set up Scenes. Once you create the scenes simply copy them to the prodrive opener.



Quick Start

Use the Quick Start guide in this manual to learn how to create access scenes with prodrive. The Quick Start Guide will take you through the Install, Setup, Match and Go! steps to create a simple network. Once you become familiar with the steps you can create your own custom scenes to match any access needs.

Go!

Press a button on the keychain remote control to open the door and trigger scenes.

Match

Match a keychain remote control button to a scene in prodrive using the Z-Wave™ interface located on the back of the opener.



Install

In this example you will replace two standard 2-Way switches with two HomeSettings in-wall dimmer switches. The HomeSettings dimmer switches are model number HA-06WD.

Follow the instructions which ship with the HA-06WD to remove the old switches and to install the new ones.

For the example, switch one is wired to the inside garage lights. Switch two is wired to the carriage lights outside the garage. HA-06WD in-wall dimmer switches wire exactly the same way as a standard 2-way switch. Furthermore, once installed the HA-06WD in-wall dimmer switches can be used manually to dim, turn off and turn on the load in the same manner as a standard dimmer.

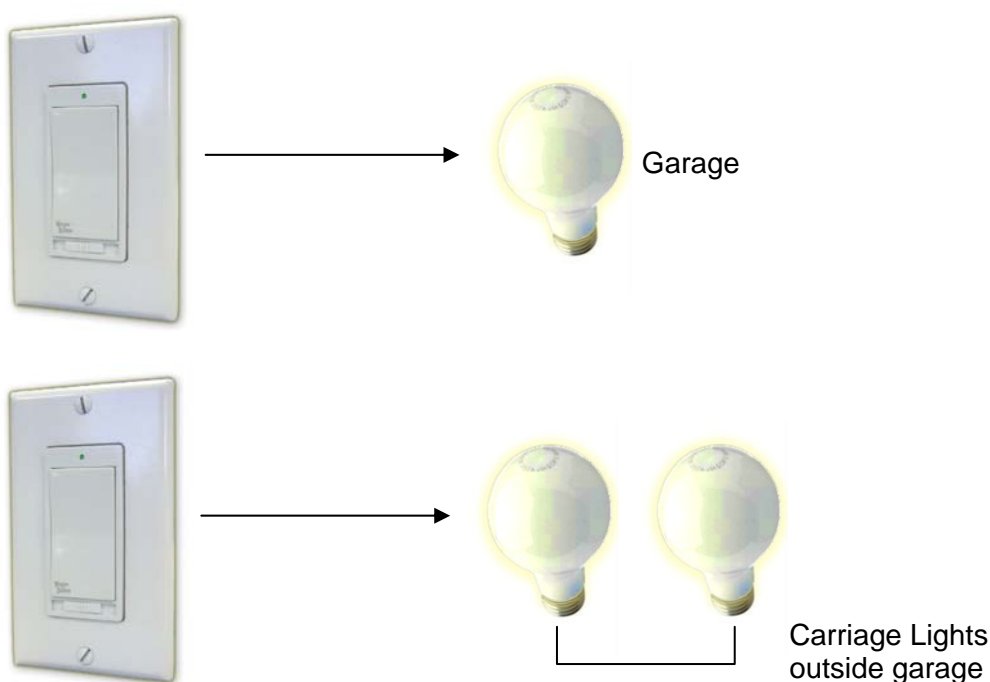

At this time the two in-wall light switch dimmers should be installed and working manually. Furthermore, the prodrive opener must also be installed and working per the installation and owners manual.

SETUP

Once the opener and the two in-wall dimmer switches are installed it is time to set up scenes. In order to create scenes a portable controller is needed. For this example an HA-09WD Remote Control will be used. Other controllers such as the HA-07WD Deluxe Remote Control or the WDHA-12R Wireless Gateway can also be used in this step.

For detailed instructions on how to use the portable remote controls please see the documentation that ships with each controller.

To add the switches to the Network repeat the steps below for each of the two in-wall dimmer switches.

1. Slide down the button cover on the HA-09WD Remote control to expose the "Include" and "Delete" buttons.
2. Press and release the "include" button.
3. Press and release the dimmer's paddle (either dim up or dim down).
4. Green LED on the Remote will light up solid momentarily indicating success.



HA-09WD

Create Scene 1

Once the switches are in the network you can create scenes. The scenes we are about to create will be transferred to the prodrive opener later on. Prodrive can handle up to 4 scenes. Scene one is special in that it will automatically trigger every time the door goes up and down. Furthermore, all of the modules in scene one will automatically turn off after five minutes.

For this example we only want the inside garage lights in scene one since the opener will turn off all modules in scene one after five minutes.

1. Press and hold simultaneously scene one "on" and "off" buttons.
2. Once the LED's on the remote control begin to flash release the buttons.
3. Press and hold the "include" button on the remote control.
4. Press the paddle on the in-wall dimmer switch to dim up the light to full on.
5. Release the paddle on the in-wall dimmer switch.
6. Release the "include" button on the remote control.
7. The LED on the remote control will blink solid green indicating success.

Create Scene 2

Use the same process as outlined above to create scene two. Create the scene to turn on the carriage lights only.

Create Scene 3

Use the same process as outlined above to create scene three. Add the carriage light switch in the "off" state. In other words in step 4 above press the paddle on the in-wall dimmer switch to turn the light off. Once you set up this scene, pressing the "on" or "off" button on scene 3 will turn off the carriage lights.

Copy Scenes to prodrive™

Once the three scenes are created they must be copied from the HA09-WD Remote Control to the prodrive garage door opener. To do so;

1. Press and hold the “include” button on the Remote control.
2. After five seconds the LED’s will begin flashing. Release the “include” button.
3. Press and release the scene one “on” button. The green LED will begin flashing.
4. On the prodrive, press and hold the “Learn” button located on the back of the opener.
5. Once the LED’s begin to flash release the button.
6. The copy process will take place for several seconds. Keep the HA-09WD within 3 feet of the prodrive opener during this process.
7. The green LED on the HA-09WD remote control will flash solid green indicating success.

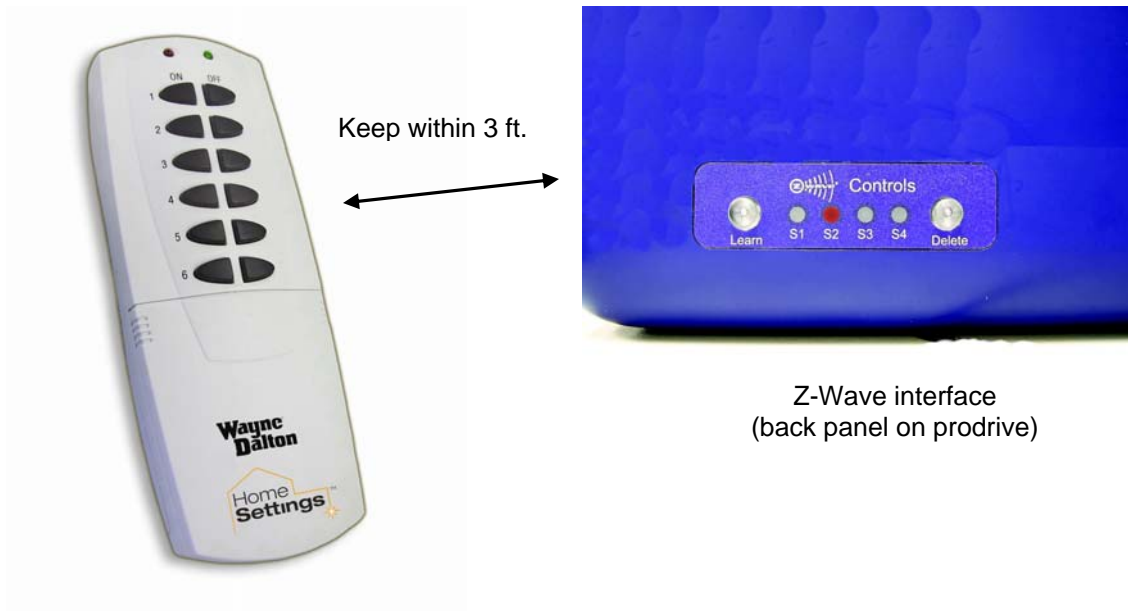

Z-Wave interface
(back panel on prodrive)

MATCH

As mentioned during the Setup process, scene one is special in that it will trigger automatically whenever the garage door goes up and down. Therefore, there is no need to match a keychain remote control button to scene one. All you have to do is press the keychain remote control button already “learned” into the opener. You will see that as the door goes up or down the built in light on prodrive will light up. Also, the garage light programmed into scene one will also light up. Typically, the large button on the keychain remote control is used to control the garage door. Make sure the large button on the keychain remote control activates the door.

See the prodrive installation and owners manual for instructions on how to “learn” a transmitter button.

Matching Scene 2

For our example, we want to push a single button on the keychain remote control to open the garage door, turn on all the lights in the garage, and also turn on the carriage lights outside. Prodrive has the ability to trigger scene 1 *and* one additional scene with the same keychain remote control button. We also want to turn off the carriage lights with another button.

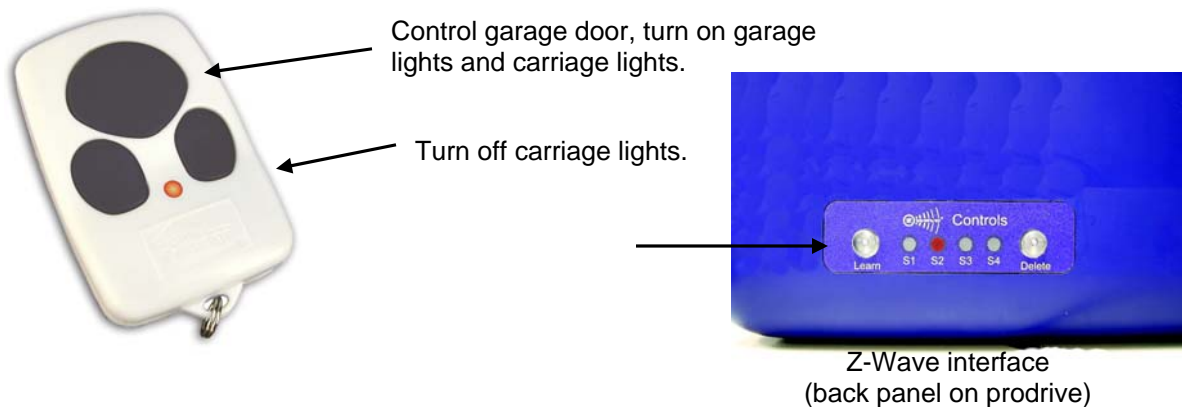

To Match the large button:

1. Press and release the “Learn” button on the Z-Wave interface (back of opener). “S2” (Scene 2) LED will light.
2. Press for one second the large button on the keychain remote control. **KEEP CLEAR OF DOOR AND OPENER AS DOOR WILL MOVE WHEN YOU PRESS THE LARGE BUTTON.**
3. Wait until the door stops motion. Once it does press the large button on the keychain remote control. The door should move, the garage lights and the carriage lights will light.

After five minutes the opener built-in light and the garage lights will turn off and the carriage lights will remain on.

Matching Scene 3

To complete our matching process we need to match scene 3 to one of the smaller buttons on the keychain remote control.

To Match the smaller button:

1. Press and release the “Learn” button on the Z-Wave interface (back of opener). “S2” (Scene 2) LED will light.
2. Press and release once again the “Learn” button on the Z-Wave interface. “S3” LED will light.
3. Press for one second the lower right side button on the keychain remote control.
4. The “S3” LED will flash indicating successful programming.
5. Press the lower right side button on the keychain remote control. Scene 3 will trigger turning off the carriage lights.

GO!

The prodrive opener is now setup with a basic access solution. By pressing the large button on the keychain remote control the door will move, and the garage lights and carriage lights will light up. After five minutes the lights in the garage automatically turn off leaving the carriage lights on. At any time you can press the lower right hand button on the keychain remote control to turn off the carriage lights.

With these basic building blocks you can now set up more useful access scenes. The prodrive garage door opener can control a large number of modules with every scene. Also, the same modules can be controlled by more than one scene.