

01-0103  
01-0104



Wayne Dalton Corporation  
P.O. Box 67  
Mt. Hope, Ohio 44660  
800-305-4349

# DoorMaster

Residential Garage Door Opener  
Model BDOR-2000/BIRW-2000



U.S. Patents: 5,929,580  
5,931,212  
Des. 413,055

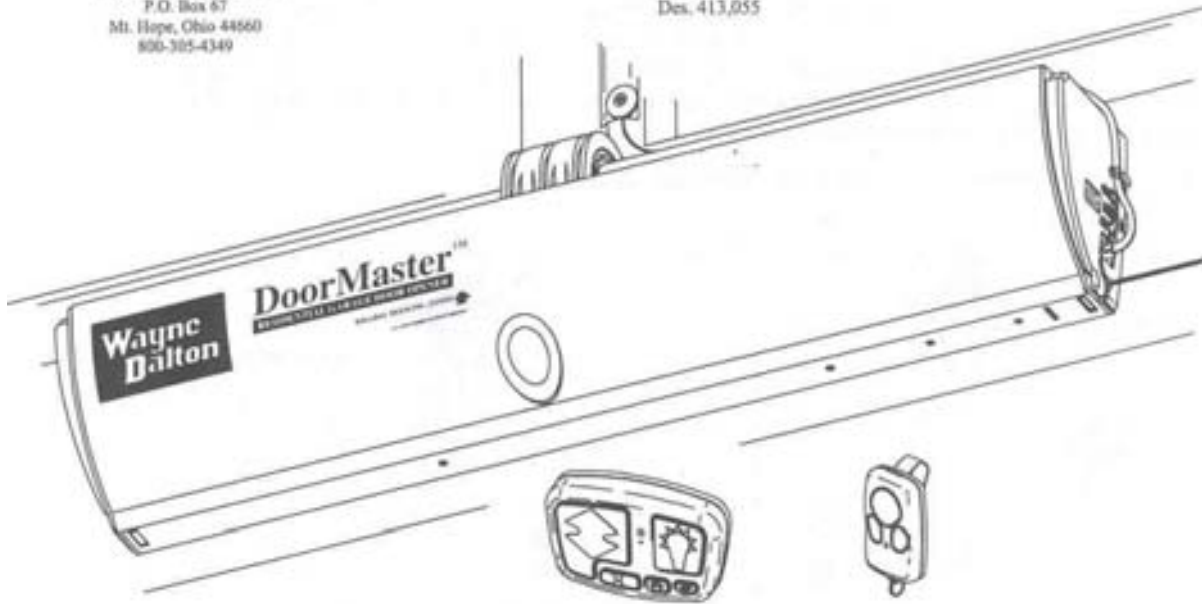

## Important Notice!

Read the enclosed instructions carefully before installing/operating this garage door operator.  
Pay close attention to all warning labels and notes.  
This manual must be attached to the wall in close proximity to the garage door.

## Table of Contents

<b>System Requirements</b> _____	2	<b>Label Placements</b> _____	16
<b>Features</b> _____	3	<b>Electrical Connections</b> _____	17
<b>Pre-Installation</b> _____	4	<b>Control Programming</b> _____	18
<b>Package Contents</b> _____	5	<b>Install Routine</b> _____	19
<b>Important Installation Instructions</b> _____	6	<b>Contact Obstruction Test</b> _____	20
<b>Cable Snubber Wrap and Lock Installation</b> _____	7	<b>Operation</b> _____	21
<b>Center Bracket/Power Head Installation</b> _____	8	<b>Maintenance</b> _____	24
<b>Emergency Disconnect Installation</b> _____	10	<b>Troubleshooting</b> _____	25
<b>Photo Electric Sensor Installation (BIRW-2000)</b> _____	11	<b>Service Parts List</b> _____	26
<b>Wall Station Installation</b> _____	13	<b>Customer Service Number</b> _____	27
<b>Light Fixture Installation</b> _____	14	<b>Warranty</b> _____	28
<b>Interface Cable Cover Installation</b> _____	15	<b>Appendix</b> _____	29

## System Requirements

**⚠ WARNING!** To reduce the risk of injury, use operator only with the following doors.

- Model BDOR-2000 will work with any WayneGard™ series door utilizing 12" radius track and a TorqueMaster™ Counterbalance System.
- Model BIRW-2000 will work with any Wayne Dalton® residential door system utilizing 12" radius track and a TorqueMaster™ Counterbalance System.

NOTE: 1. If your Wayne Dalton® door was manufactured before July 1, 1999, it may be necessary to obtain and install a Wayne Dalton TorqueMaster™ retrofit kit for Model BDOR-2000/BIRW-2000 operator. Compatible TorqueMaster™ end brackets, driven gear, and flag angles must all be present.  
 2. New drums (date stamp 2000+) are required for the new drum cover "Snubber Wrap". Retrofit kits manufactured after 6/1/2000 contain the new drums.

Refer to illustrations below to determine retrofit kit requirements.

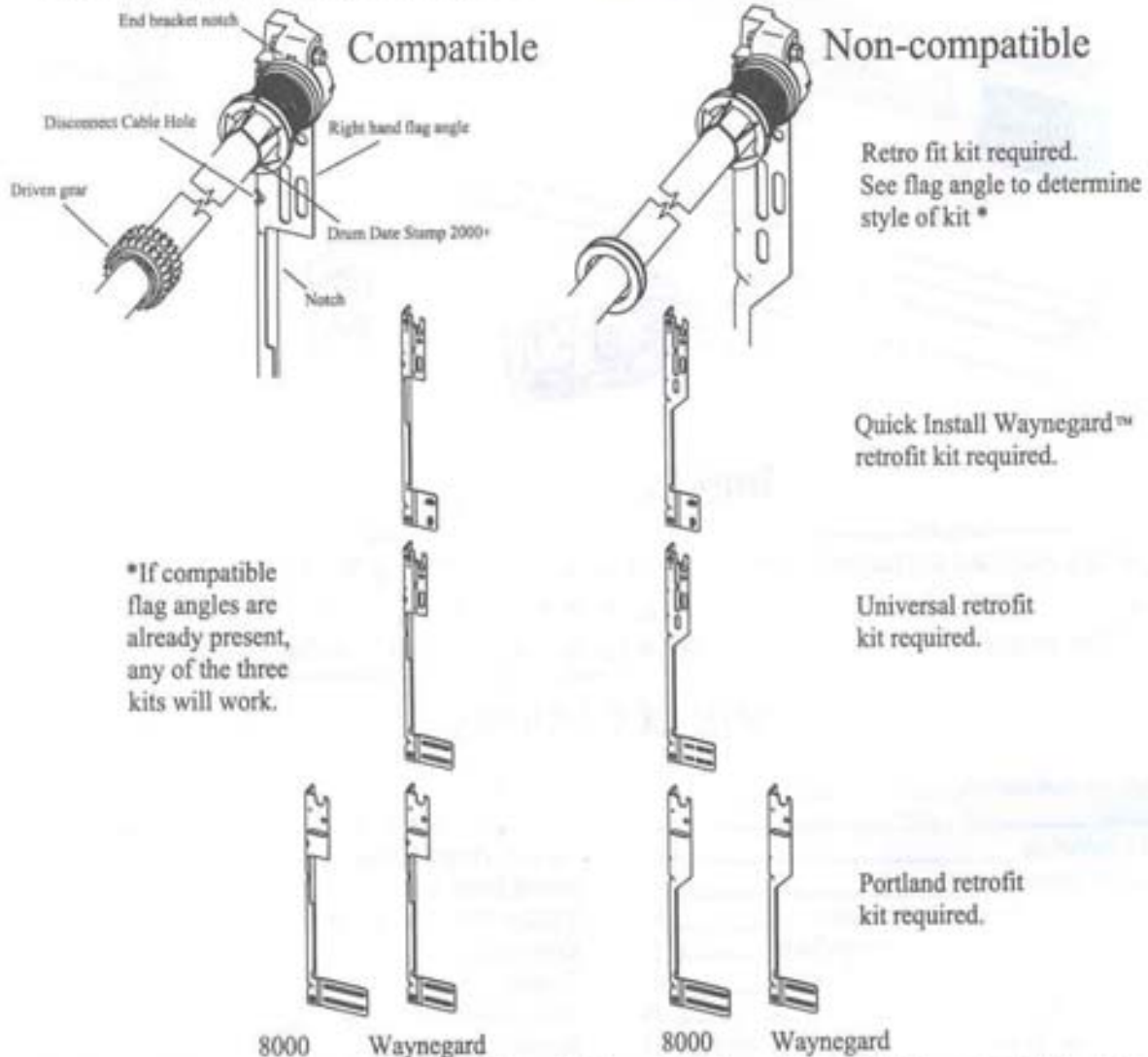

3. When installing a DoorMaster on a retrofit installation, verify the vertical track distance from the bottom of the header to the top of the vertical (track splice) is 8". Some old track has a 9" space here and will require raising the track 1" to clear DoorMaster.

# Features

## High Efficiency Motor and Drive Train Enclosed in Unique Header Mounted Case

- Requires no headroom beyond counterbalance system,
- Battery powered. Fully functional during power outages!
- Advanced electronics provide continuous monitoring of door forces and automatically stops or reverses door due to obstruction or out of balance condition.

## Deluxe Wall Station Control

- Oversized Up/Down button for easy opening and closing of garage door.
- Oversized light button for manual control of light fixture.
- Timer button for delayed door closing operation allowing user time to exit through door prior to door closing.
- Pet button automatically sets door to a slightly open position for pet access or ventilation.
- Transmitter program button allows convenient programming of remote controls.
- Convenient "one touch" limit setting.
- Wireless mounting for easy installation and clean appearance.

## Deluxe Remote Control Transmitter

- Three buttons for use with up to six separate doors.
- Secure Rolling Code: Eliminate remote door activation by would-be intruders.
- Convenient key chain or visor mounting.

## Deluxe Two Bulb Light Fixture

- Provides safety and automatic convenience light during door operation and remains on for five minutes after door motion stops.
- Can be operated independently from door operation using Wall Station Control.
- Provides signals to warn user of safety or operational problems.

## Emergency Disconnect

- Allows door to be operated manually to verify and maintain proper door balance.

## Available Accessories

- Photo electric non-contact obstruction sensor - Wayne Dalton® Model No. ML2 Model BDOR Accessory (Required on Model BIRW-2000) - P/N 285338
- Keyless entry system - Wayne Dalton® Model No. KEP1-0000 - P/N 285247  
Wayne Dalton® Model No. KEP2-0000 - P/N 288830
- Longer (25 ft) Interface Cable - P/N 285652
- Additional Remote Transmitters - P/N 285254

# Pre-Installation

Model BDOR-2000/BIRW-2000 should only be installed on a properly counterbalanced, properly operating garage door. A door that binds, sticks or is out of balance could cause severe injury. Do not attempt to compensate for an improperly adjusted door by the installation of the operator. This will interfere with the proper operation of the operator and/or damage the door and/or operator. Perform the following checks:

## Garage Door

1. Fully raise and lower garage door and check for any sticking or binding that occurs. Have a qualified service person lubricate, repair, or adjust as necessary.
2. Lift garage door approximately half way open. When released, door should stay in position. If spring tension pulls door further open or door weight pulls door further down, door is not properly balanced. Refer to TorqueMaster™ owner's manual or have a qualified service person balance door.
3. When properly installed, a door should remain clear of opening when allowed to rest at it's natural, fully opened position. Refer to TorqueMaster™ owner's manual or have a qualified service person balance door.
4. Lift door to full open position. Manually rotate TorqueMaster™ torque tube to allow door to descend. If suspension cables go slack leaving door hanging in horizontal track, have a qualified service person incline horizontal track until door descends during torque tube rotation.

## Operator

Unpack and inspect carefully for any possible shipping damage or missing parts. Refer to illustration on page five. Do not attempt installation if any parts are damaged or missing.

In order to prevent binding of the torque tube with the power head, the shipping carton has two alignment spacers incorporated into the two inserts for proper torque tube to power head alignment. Detach the alignment spacer from each insert. Alignment spacers will be used on Step 2, Center Bracket/Power Head Installation.

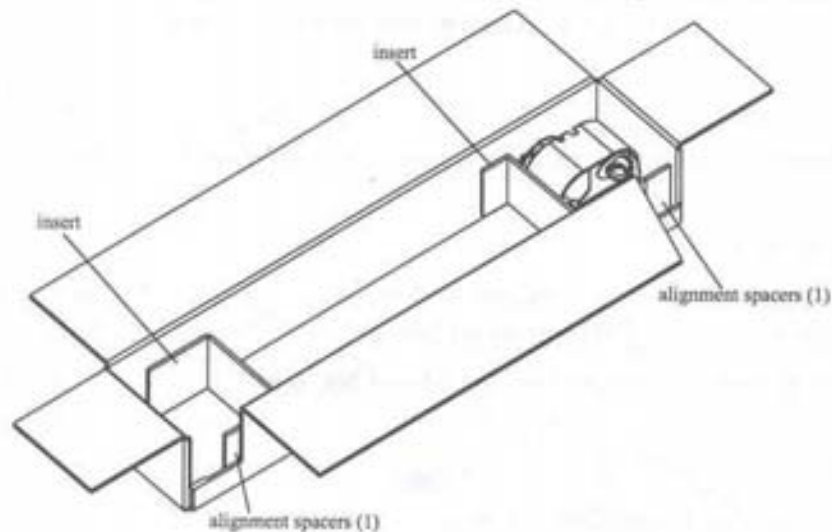

# Package Contents

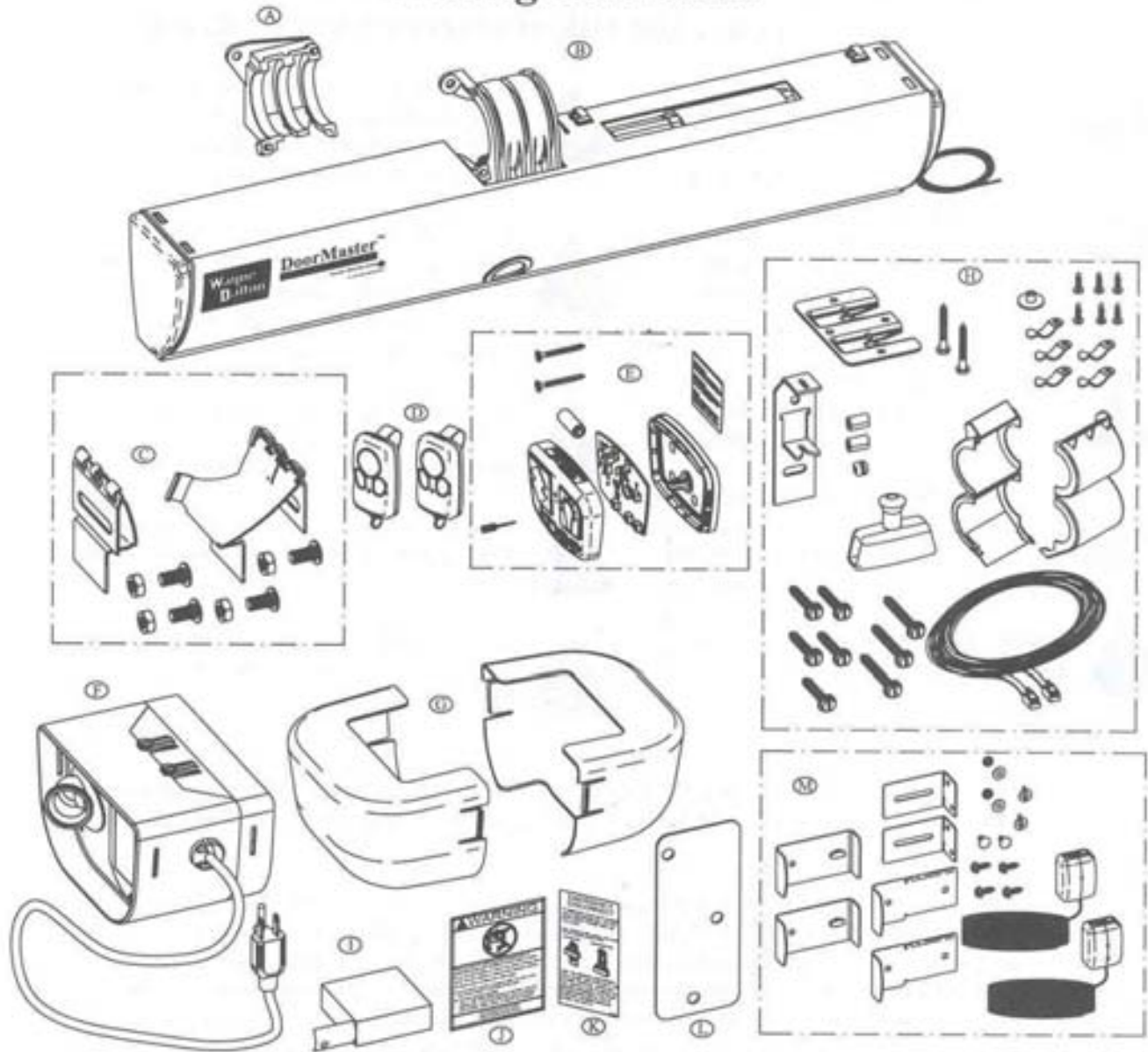

- |  |                                    |  |
|--|------------------------------------|--|
| (A) Die Cast center Bracket [1]                  | (G) Diffusers [2]                  | (M) Photo Electric Sensors (Model BIRW-2000) [1 set] |
| (B) Power Head Unit [1]                          | (H) Hardware Pack [1] (***)        |  |
| (C) Cable Lock set (1 Right/1 Left Hand) [1] (*) | (I) Interface Cable Cover Roll [1] |  |
| (D) Radio Transmitters (Remote Control) [2]      | (J) Entrapment Warning Label [1]   |  |
| (E) Wall station Kit [1] (**)                    | (K) Emergency Disconnect Label [1] |  |
| (F) Light fixture [1]                            | (L) Drywall Adapter [1]            |  |

- (\*) (1) Left Hand Lock Assembly, (1) Right Hand Lock Assembly, (4) 3/8" Rib Neck Bolts, (4) 3/8" Nuts
- (\*\*) (1) Cover/Button Assembly, (1) Base, (1) 12 Volt Battery, (1) Reference Card, (1) Programming Tool, (1) Circuit Board, (2) #6 x 1-1/4" Wood Screws
- (\*\*\*) (5) 1/4 x 1-1/2" Lag Screws, (3) 1/4 x 2" Lag Screws, (2) #10 x 1-1/2" Wood Screws, Light Fixture Bracket, Grommet, (2) Cable Crimp Sleeve, Disconnect Handle, Snubber Wrap Set, Handle Bracket, (5) Cable Cover Clips, Cable Cover Bushing, (6) #6 x 7/8" Pan Head Screws, Interface Cable

## IMPORTANT INSTALLATION INSTRUCTIONS

### WARNING: To reduce the risk of severe injury or death:



READ AND FOLLOW ALL INSTALLATION INSTRUCTIONS.



Install only on a properly balanced garage door. An improperly balanced door could cause severe injury. Have a qualified service person make repairs to cables, spring assemblies and other hardware before installing operator.



Remove all ropes and remove or make inoperative all locks connected to the garage door before installing operator.



Where possible, install the door operator 7 feet or more above the floor. For products requiring an emergency release, mount emergency release 6 feet above the floor.



Do not connect operator to source of power until instructed to do so.



Locate the wall station: (a) within sight of door, (b) at a minimum height of 5 feet so small children can not reach it, and (c) away from all moving parts of the door.



Install entrapment warning label next to wall station in a prominent location. For products requiring an emergency disconnect, install the emergency release marking on or next to the emergency release.



After installing operator, the door must reverse when it contacts a 1-1/2 inch high object (or a 2 x 4 board laid flat) on the floor.



Do not wear rings, watches, or loose clothing when installing or servicing a garage door system.



Installing and wiring must comply with local building and electrical codes. Connect the power cord to a properly grounded outlet. Do not remove ground pin from power cord.

AFTER INSTALLATION IS COMPLETE, FASTEN THIS MANUAL NEAR GARAGE DOOR. PERFORM PERIODIC SAFETY CHECKS, MAINTENANCE AND ADJUSTMENTS, AS RECOMMENDED.

NOTE: This equipment has been tested and found to comply with the limits for a Class B digital device, pursuant to Part 15 of the FCC Rules. These limits are designed to provide reasonable protection against harmful interference in a residential installation. This equipment generates, uses and can radiate radio frequency energy and, if not installed and used in accordance with the instructions, may cause harmful interference to radio communications; However, there is no guarantee that interference will not occur in a particular installation. If this equipment does cause harmful interference to radio or television reception, which can be determined by turning the equipment off and on, the user is encouraged to try to correct the interference by one or more of the following measures: Reorient or relocate the receiving antenna. Increase the separation between the equipment and receiver. Connect the equipment into an outlet on a circuit different from that which the receiver is connected. Consult the dealer or an experienced radio/television technician for help. WARNING: Changes or modifications to this unit not expressly approved by the party responsible for compliance could void the user's authority to operate this equipment.

#### FCC/INDUSTRY CANADA REGULATORY INFORMATION

Operation is subject to the following two conditions: (1) this device may not cause interference, and (2) this device must accept any interference, including interference that may cause undesired operation of the device.

**Important!** Do not add "pre-wrap" turns of cable to the TorqueMaster drum when using the snubber wraps.

# Installation

## 1 Cable Snubber Wrap and Lock Installation

**Cable Snubber Wrap Installation** - See appendix for installation instruction of metal snubber bracket.

Locate right hand snubber. Remove the #10 self-tapping screw from the TorqueMaster end bracket, if it is installed. (1) Slide back half of snubber behind drum locating the right end wall between the drum and flag angle. (2) Close front half of snubber around drum, engage inboard snap and press firmly until a distinct snap is felt. (3) Engage outboard catch as shown. Confirm both snap and catch are fully engaged by lightly tugging against them.

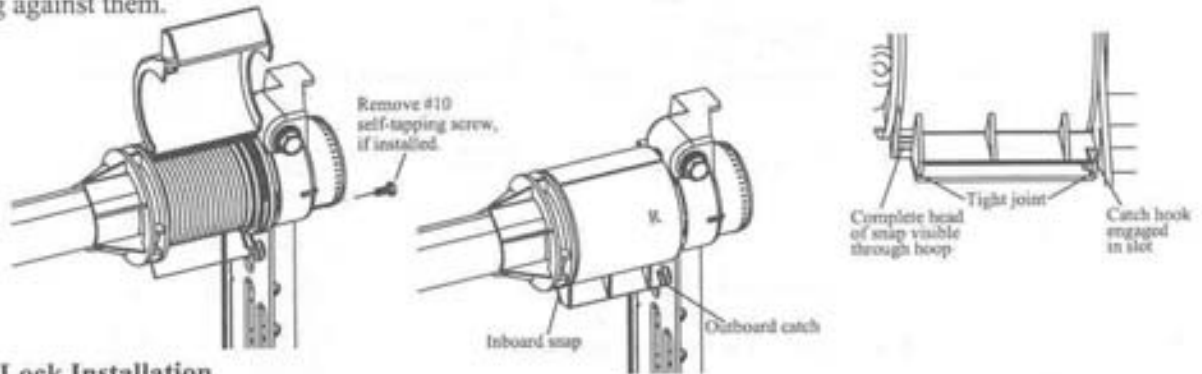

### Cable Lock Installation

Verify that horizontal angle is right side up (as shown in B, C, D). If angle is upside down (as shown in A) swap right and left hand horizontal angles.

Locate right hand cable lock components. Position lock along horizontal angle so that hook of arm will fit closely behind the door cable but not rub against back of cable. Align holes in lock with corresponding holes in horizontal angle. Once aligned, secure Lock to track using (2) 3/8" rib neck bolts and nuts (B). Lock arm should pivot freely at spring loaded hinge. Gently raise door to confirm cable lock is adjusted to stop door from opening. Cable lock's horizontal surface should come into contact with top of door and cable lock's vertical surface should be parallel with side of door. Adjust lock arm travel by bending stop tab so lock arm will not pivot beyond side of door. Pivot lock arm downwards and slide counterbalance cable in front of arm (D).

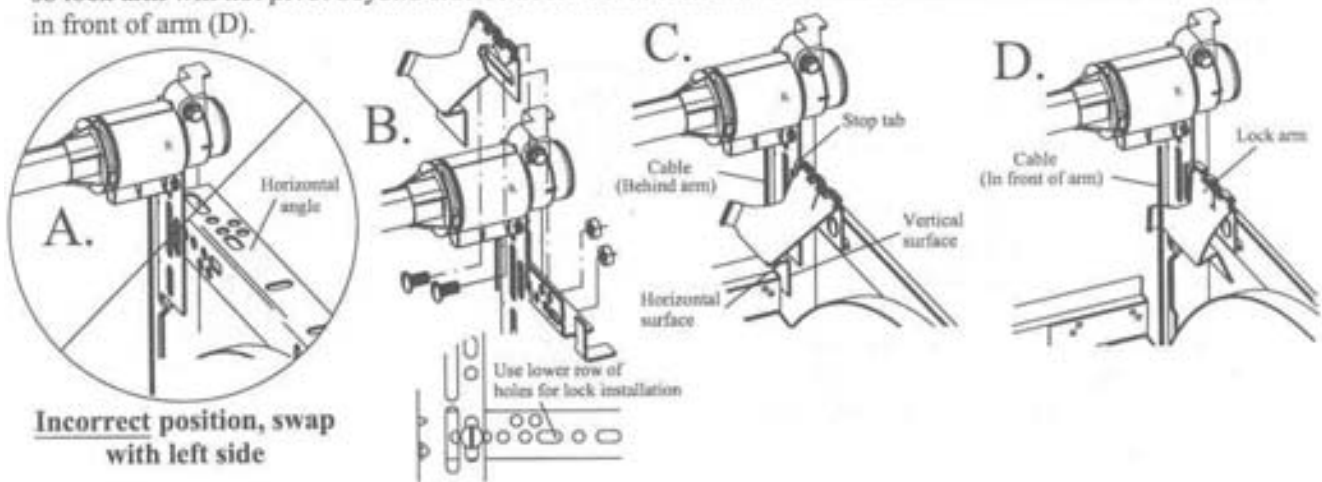

Repeat Cable Snubber Wrap and Lock Installation for opposite side.

2

## Center Bracket/Power Head Installation

For operator installation, a wood anchor pad must be firmly attached to the wall, above the header board and flush with the header board at the **center** of the door section. Refer to the "Preparing The Opening" section of the "REMOVING THE OLD DOOR/PREPARING THE OPENING" Supplement Installation Instructions sheet included in the retrofit or door package for anchor pad installation.

If installing operator on a StormGard series door, operator location will vary. The power head must be mounted on torque tube so there are no obstructions between power head and right hand edge of door. Depending on StormGard door model, power head location will vary as illustrated.

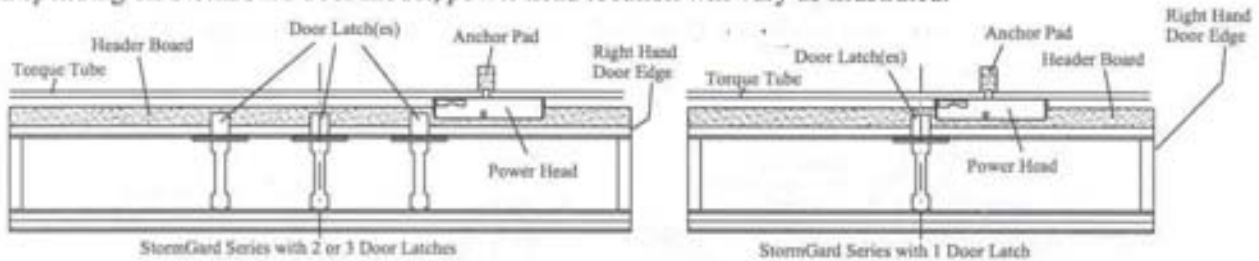

### Center Bracket

Bend tab out of way as shown. Remove (2) lag screws from TorqueMaster center bracket and remove bracket.

**NOTE: Do not discard if installing on a StormGard door with 2 or 3 door latches.**

**StormGard doors w/2 or 3 door latches only:** Stamped center bracket will be reused with TorqueMaster center bushing. Install stamped center bracket onto bushing in reverse order of removing bracket and gear. Mount center bracket and bushing centrally on torque tube between operator and left door edge as illustrated. **NOTE:** A second anchor pad for TorqueMaster bracket may be needed for proper mounting.

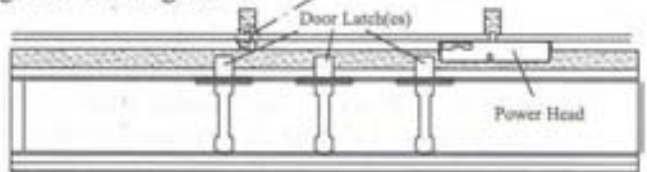
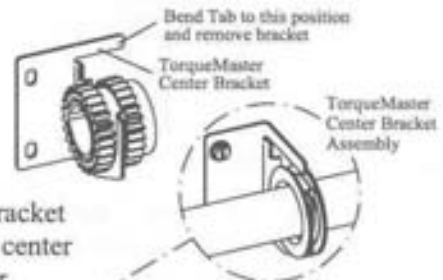

**IMPORTANT: The anchor pad and header board must be flush to provide a flat mounting surface for power head.**

**NOTE:** If anchor pad is covered by drywall, a drywall adapter must be installed between center bracket and the wall with 1/4 x 2" lag screws.

If applying center bracket directly to wood framing, mount center bracket with 1/4 x 1-1/2" lag screws and discard drywall adapter.

Slide operator center bracket onto driven gear from underneath. Next, position center bracket up or down to level torque tube with top of door and secure center bracket to anchor pad with (1) 1/4" lag screw in bottom hole as shown.

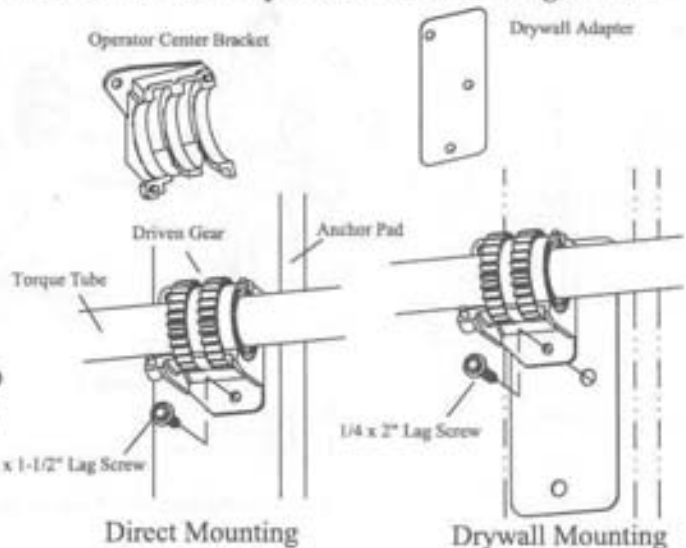



## Center Bracket/Power Head Installation Cont'

Unravel interface cable and pre-install cable into (2) cable clips leaving enough cable to plug into right hand endcap. Route interface cable behind torque tube as shown. Engage power head to center bracket, aligning holes "A" with pins "B" and meshing gears.

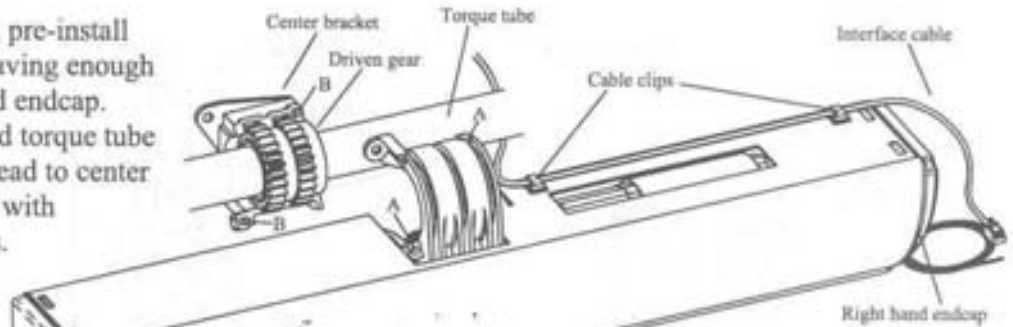

After placing power head onto driven gear and center bracket, slide alignment spacers between torque tube and power head; one on either side of driven gear as illustrated.

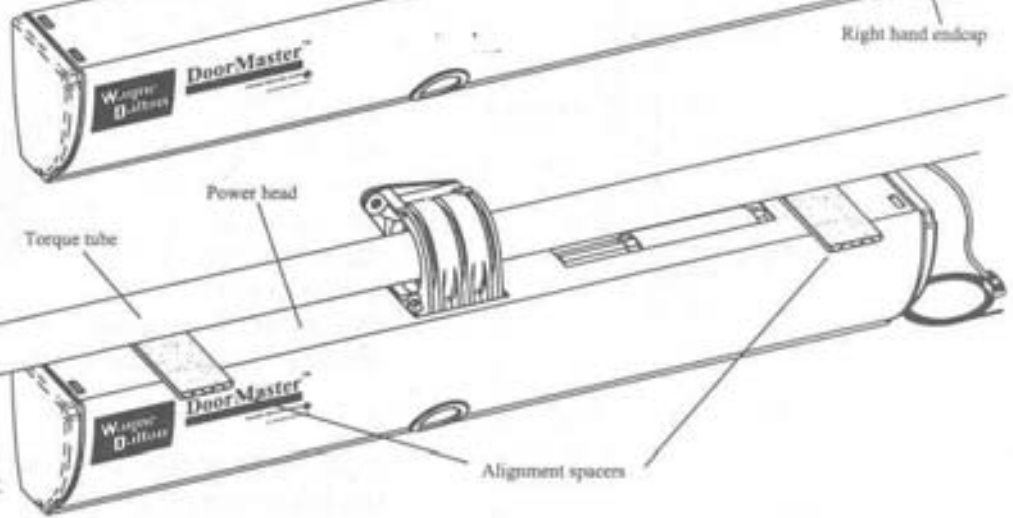

**NOTE:** Make sure pins "B" are aligned with holes "A". Care should be taken to drive lag screws straight. Drilling 5/32" to 3/16" pilot holes are recommended.

Secure upper lag screw first. Important: To avoid possible damage, this mounting foot must be supported underneath by a solid mounting surface before tightening lag screw. Secure lower lag screw. Remove alignment spacers.

**NOTE:** All leveling adjustments of power head must be done prior to driving either of these last two lag screws.

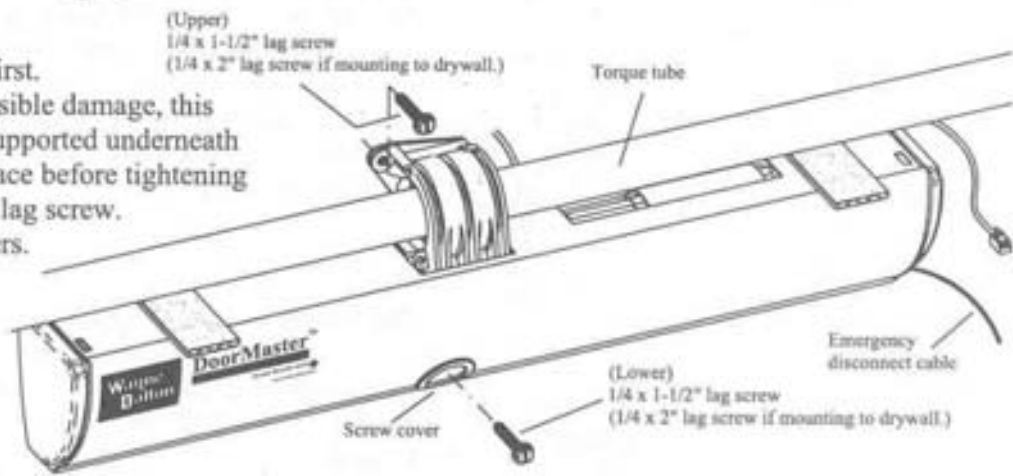

Insure door moves freely.

Unravel emergency disconnect cable.

Once all lag screws are secure, remove emergency disconnect clip by pulling clip to the right and down until clip is removed. Discard clip.

Rotate torque tube slightly by hand, in the door closing direction, until power head and torque tube lock together.

**Important:** Do not remove emergency disconnect retention clip until power head gears are engaged and all lag screws secured.

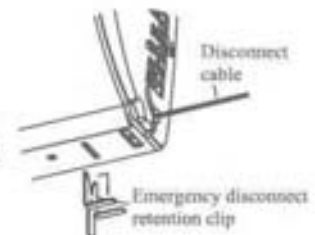

## 3 Emergency Disconnect Installation

**A.**  
Install grommet into right hand flag angle.

**B.**  
Thread disconnect cable through grommet.

**C.**  
Mark location on right door jamb 6 feet above the ground to mount disconnect handle.

**D.**  
Thread disconnect cable through handle bracket, disconnect handle, and cable sleeve as shown.

**NOTE:** To ease cable installation, bend end of cable with pliers as shown before threading through handle.

Align handle bracket with mark on wall, slide cable sleeve to where cable exits handle.

**E.**  
Route cable back through sleeve, flatten cable loop, slide sleeve over loop until flush, and crimp sleeve with pliers or crimping tool as shown.

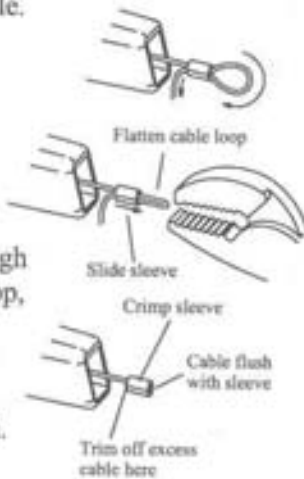
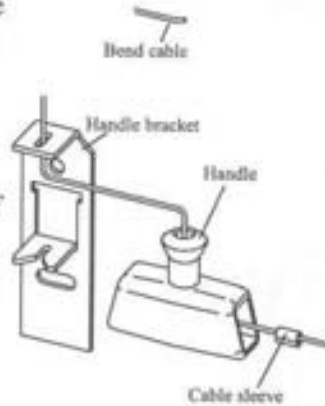
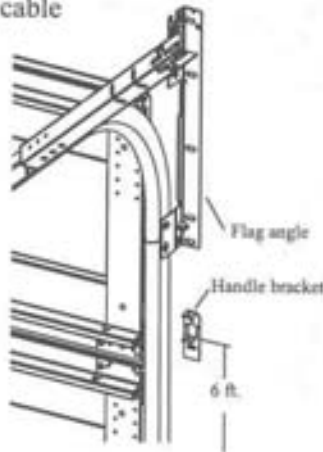
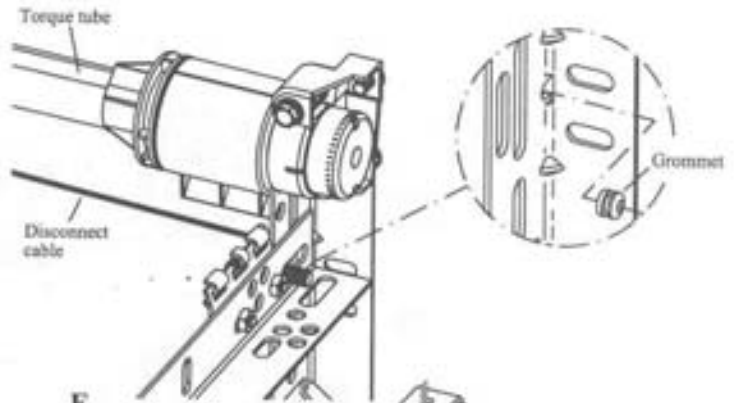

**F.**  
Slide handle over crimped cable sleeve until sleeve is firmly seated in center of handle as shown.

**Important! Firmly seat sleeve in handle before mounting handle bracket.**

**G.**  
Slide handle bracket down just enough to remove cable slack between power head and flag angle.  
**NOTE:** Pulling cable beyond this point will start disengaging power head. Secure handle bracket to jamb with (1) 1/4 x 1-1/2" lag screw in bottom hole.

**H.**  
Pull handle aside until upper hole is exposed in handle bracket and secure handle bracket with another 1/4 x 1-1/2" lag screw in upper hole.

Test disconnect operation.

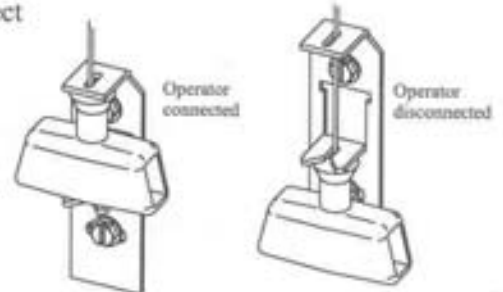
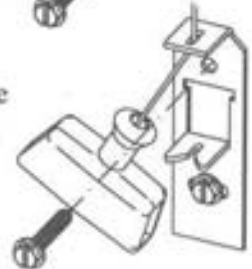
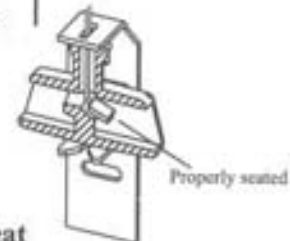

## Photoelectric Sensor Installation

**NOTE:** Proceed to Wall Station Installation if installing Model BDOR-2000 Operator. Continue with Photo Electric Sensor Installation for Model BIRW-2000. Photoelectric sensors are not required on the BDOR-2000 model, however, they are available as an optional accessory (P/N 285338).

### STEP 1: Wall Bracket Installation

Select a mounting position 5 inches above floor to center line of wall bracket. Sending and receiving units should be mounted inside door opening to minimize any interference by the sun. However, sensors should be mounted as close to door track or inside edge of door as possible to offer maximum entrapment protection. It is very important that both wall brackets be mounted at the same height for proper alignment.

Using 1/4" x 3/4" lag screws provided, attach wall mounting bracket to wall. In some installations it may be necessary to attach wooden spacers to wall to achieve required clearance. Expansion bolts (not supplied) may be required to attach brackets to walls constructed of materials other than wood or gypsum.

Slide adjusting brackets on top of wall mounting brackets and secure, using 1/4-20 carriage bolts, washer, and nuts supplied. Do not tighten at this time. Make sure alignment allows for sending and receiving units to point toward each other and that they will not be obstructed by door tracks or other objects.

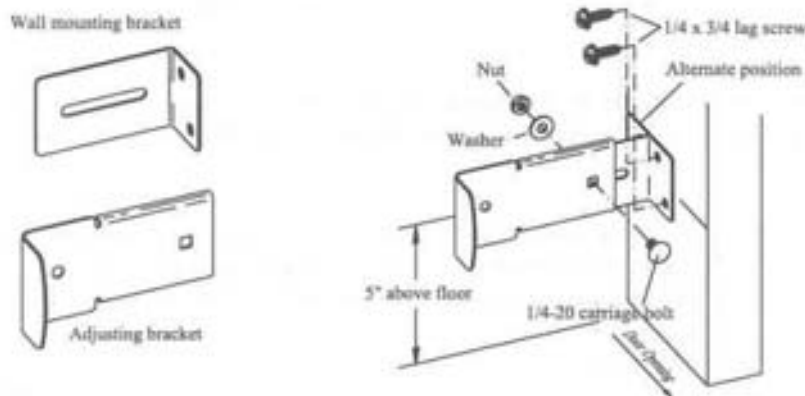

### STEP 2: Quick Install Bracket Installation

Two bracket mounting heights are available for use. Normally the upper mounting slot is used, but if bottom of track is installed more than 1/2" off of floor the bottom slot may need to be used to maintain 6" maximum photo beam height. Slip the slide lock tab into the door track mounting slot. Slide the bracket downward until it seats at the bottom of the slot. Repeat for opposite side. If needed, use a flat blade screwdriver against the top edge of the bracket and gently tap into position with hammer.

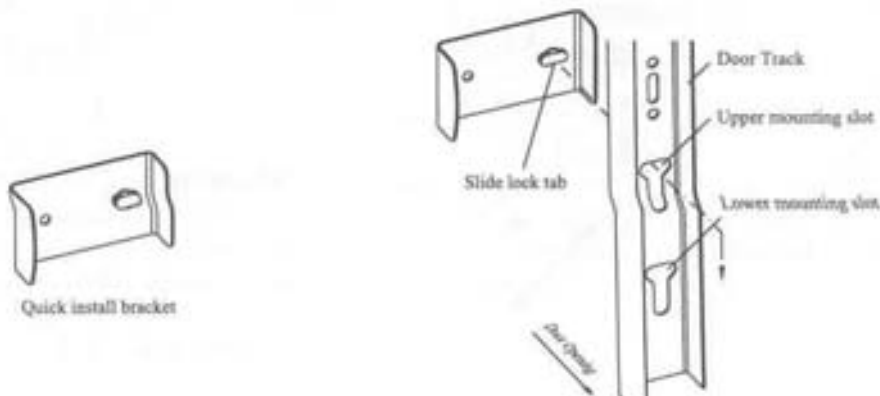

Identify which side of garage door opening (if any) the sun is "likely" to shine on to. Since sunlight may affect photoelectric sensors, sending unit (not the receiving unit) should be mounted on side of door opening exposed to sun.

Place photo eye stem through hole in mounting bracket (quick install or wall mount) with wiring exiting bottom of sensor housing. Screw zip nut onto stem supporting housing with palm of one hand until housing is fully seated against bracket. Repeat for opposite side.

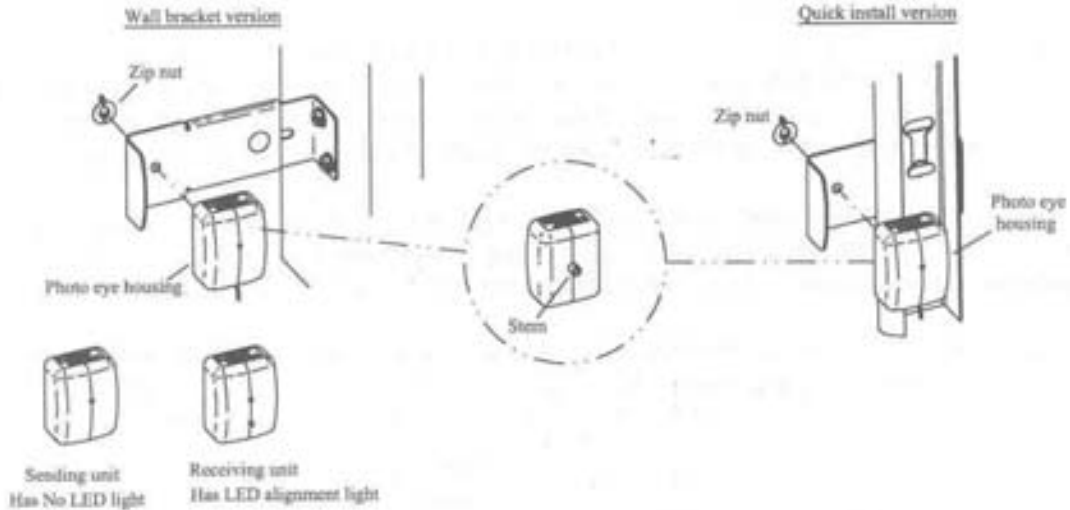

Uncoil wires from photoelectric sensors and route wire up garage wall and along door header towards right side of power head. Route wires behind torque tube and tack wires in place with insulated staples (not supplied).

Connect photoelectric sensors to power head as shown. Solid color wires connect to COM terminal and wire with a black stripe connects to OBS terminal. Shorten wires as necessary and separate wire ends. Strip about 1/2" of insulation off each wire and attach wire to proper terminals, then tighten securely, using a small blade screwdriver.

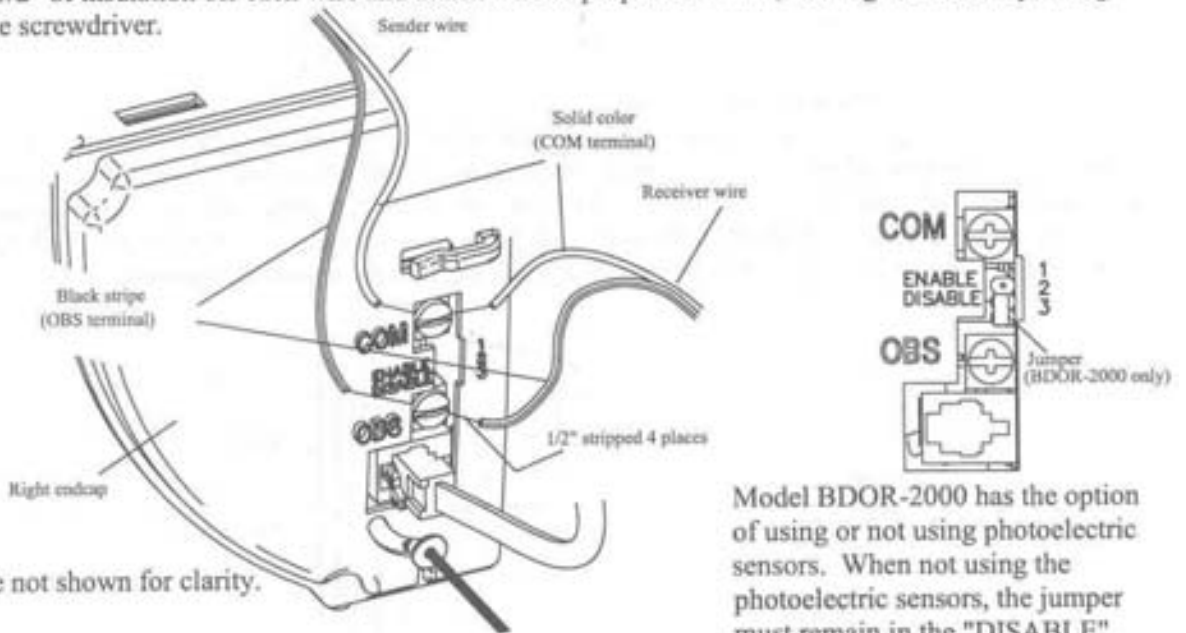

Torque tube not shown for clarity.

Model BDOR-2000 has the option of using or not using photoelectric sensors. When not using the photoelectric sensors, the jumper must remain in the "DISABLE" position (pins 2 & 3).

## 5 Wall Station Installation

Locate a convenient place to mount wall station. Measure five feet up from floor and secure wall station base into wood wall framing using (2) #6 x 1-1/4" phillips drywall screws. Use two left side holes for vertical framing or two bottom holes for horizontal framing. Use drywall anchors if not fastening to wood. Caution: Overtightening of screws into wood could deform the plastic base and interfere with circuit board snaps.

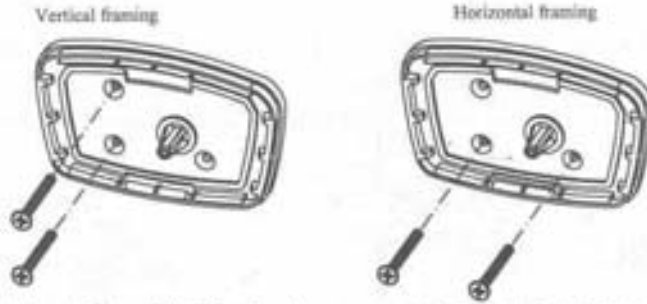

Insert bottom of circuit board behind bottom snap of wall station base. Pivot circuit board up until board snaps into place. For best results, press on circuit board between two battery terminals as shown.

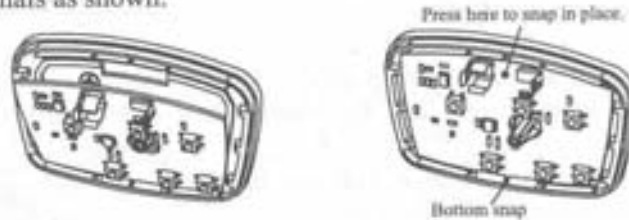

Insert battery into circuit board being careful to match (+) positive battery marking with (+) positive circuit board marking.

Align wall station cover/button assembly with base and circuit board. Press cover over base until cover snaps into place. A uniform seam between cover and base indicates a proper installation.

Apply the wall station operation reference label in a convenient location next to the wall station.

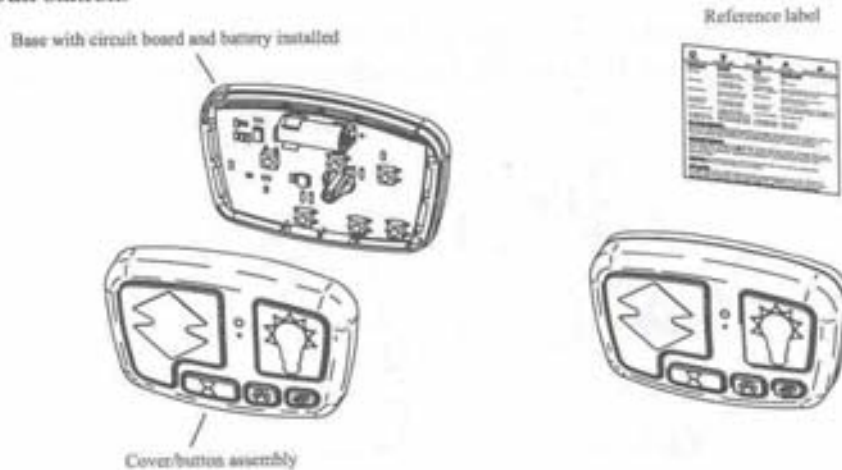

## 6 Light Fixture Installation

Before installing fixture bracket to ceiling, pre-assemble bracket to light fixture snap posts to become familiar with the force required to engage snaps. Remove bracket from light fixture.

Find a location on the ceiling, within four feet from a 120 volt grounded electrical outlet and within reach of the Interface Cable from power head, to mount light fixture. NOTE: Door must clear light fixture when door is in the up position.

Orient and secure fixture bracket to ceiling using (2) #10 x 1-1/2" wood screws as shown. NOTE: Make sure screws are installed into wooden ceiling framing members and not just into drywall. There are two sets of holes in brackets 90° apart to insure screws are secured into a wooden frame member.

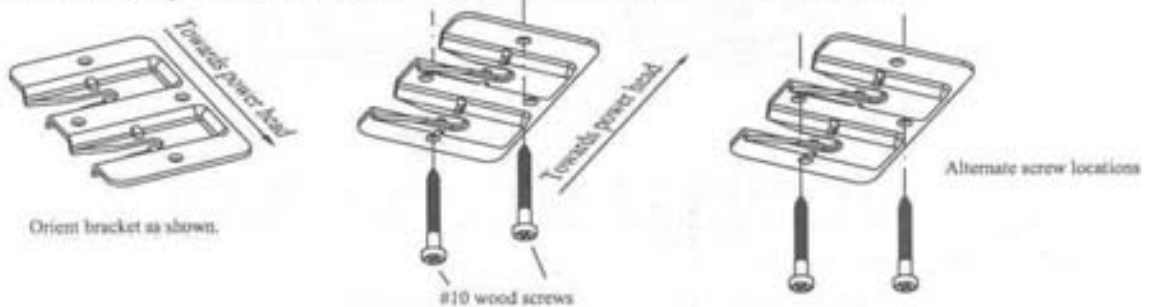

Align two snap posts on light fixture with two corresponding slots in fixture bracket, making sure interface socket is facing towards power head as shown. Slide light fixture into fixture bracket as shown until light fixture snaps into place.

*HINT: As snap posts start to engage resistance, snap one side then the other to reduce force required to snap in place.*

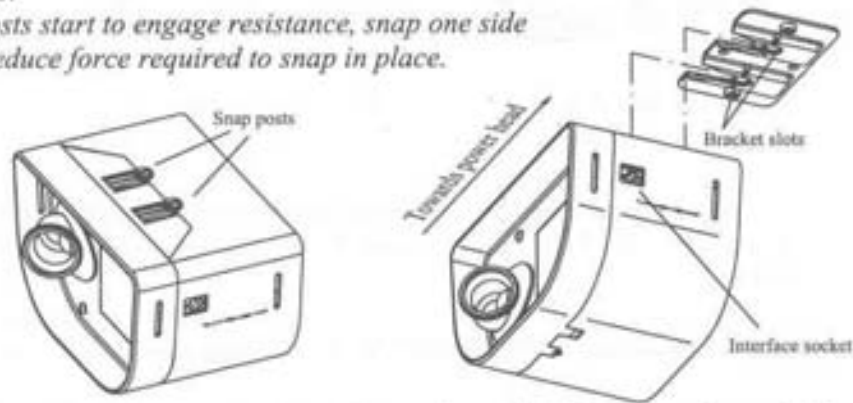

Install a 75 Watt maximum bulb into each socket. For maximum bulb life, "rough service" bulbs are recommended. Snap diffusers into light fixture by squeezing two snaps together as diffusers are inserted into light fixture.

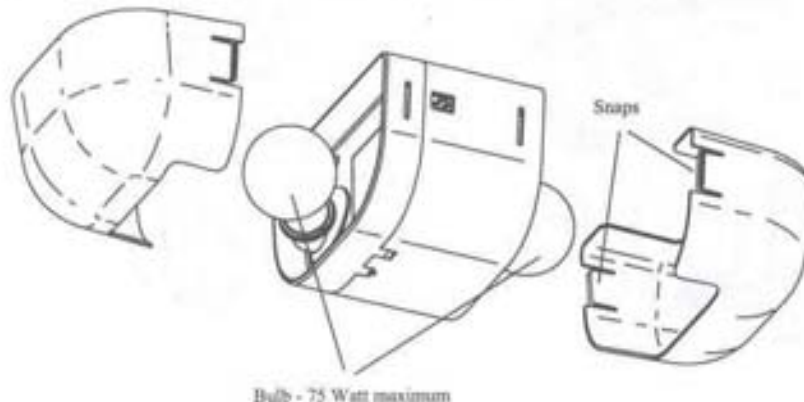

7

## Interface Cable Cover Installation

Cable Cover is used to shield and support Interface cable. Depending on ceiling height, cable cover may need to be trimmed to fit. Measure distance along ceiling from light fixture to front of wall and along wall from ceiling down to power head. If necessary, trim cable cover to this total length.

### Method 1.

Insert bushing into hole in cable cover end. Position cable cover and bushing above power head, against wall, and secure with (1) #6 x 7/8" philips pan head screw through bushing into wall. Route cable cover up wall, onto ceiling and secure cable cover to ceiling using a #6 x 7/8" philips pan head screw through a cable cover clip as shown. Route cable cover in a straight line from power head to light fixture installing cable cover clips equidistant from each other making sure the clips are all oriented the same way as shown.

### Method 2.

Insert bushing into hole in cable cover end. Position cable cover and bushing on ceiling centered at light fixture and secure with a #6 x 7/8" philips pan head screw. Route cable cover, in a straight line, towards power head and secure cable cover to ceiling, just before the ceiling and the wall meet, with a cable cover clip and a #6 x 7/8" philips pan head screw. Run cable cover down wall towards the power head and secure cable cover end with another clip and screw. Place remaining clips and screws along ceiling equidistant apart taking up slack of cable cover between light fixture and power head making sure all clips are oriented the same way as shown.

Once cable cover is secure, slide interface cable between cable cover and ceiling until interface cable is hidden from sight. If excess cable remains at light fixture, wrap excess cable around light fixture between ceiling and light fixture.

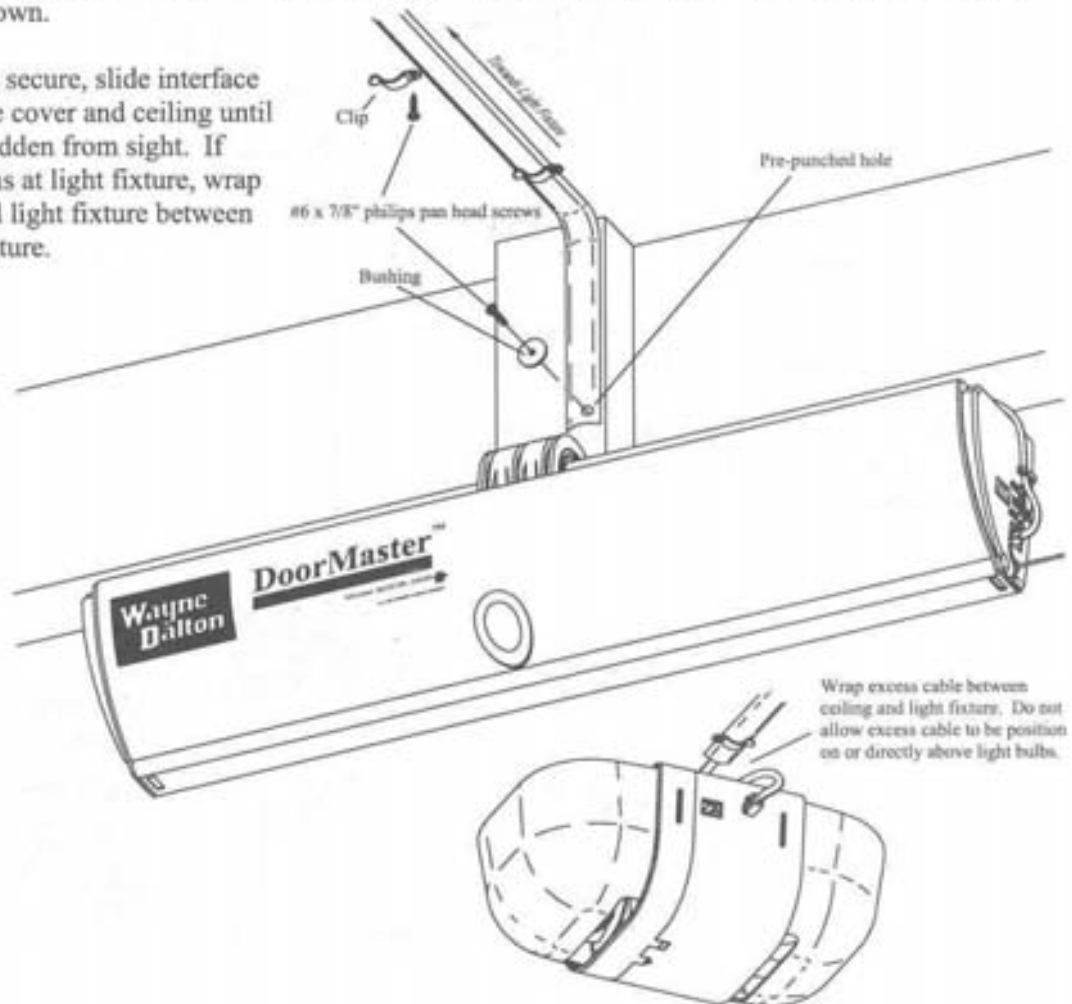

8

# Label Placements

## Entrapment Warning Label



Install entrapment warning label next to wall station in a prominent place.

Use mechanical fasteners to attach entrapment warning label to surfaces to which adhesive will not adhere.

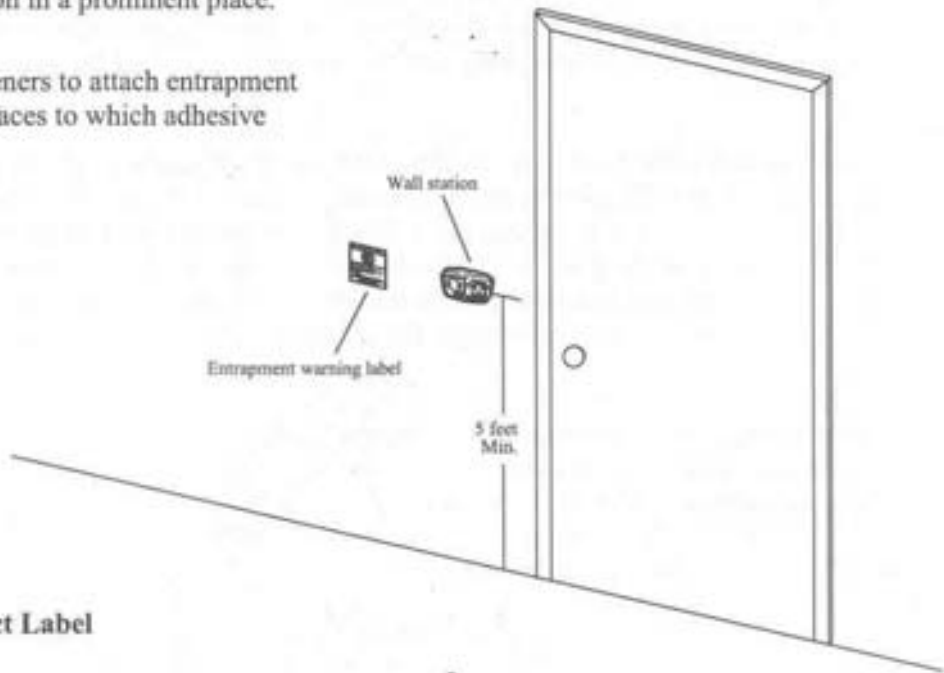

## Emergency Disconnect Label

Install emergency disconnect label next to emergency disconnect handle on right door jamb.

Use mechanical fasteners to attach emergency disconnect label to surfaces to which adhesive will not adhere.





## 9 Electrical Connections

Remove left hand endcap by applying pressure to bottom snap with screwdriver, then rotating bottom of endcap outward until endcap is removed accessing battery connectors. Next, attach male battery pack connector to female power head connector. Tuck connectors and excess wiring into power head and reinstall endcap.

Note: Do not force (pull) wires. If more length is needed to couple connectors, lift male connector wires from wire clip on end of battery tray. The battery tray may also be partially pulled out to provide more access.

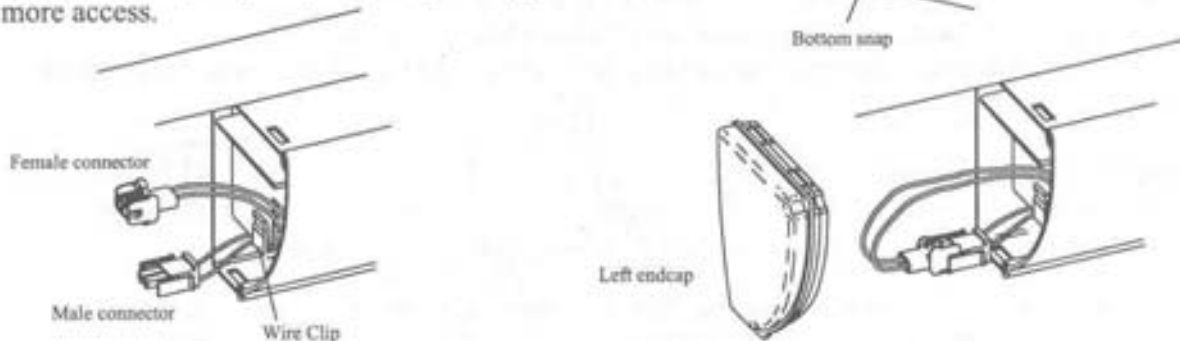

Slide interface cable into endcap clip and then plug connector into power head interface jack. Plug opposite end of interface cable into light fixture interface jack.

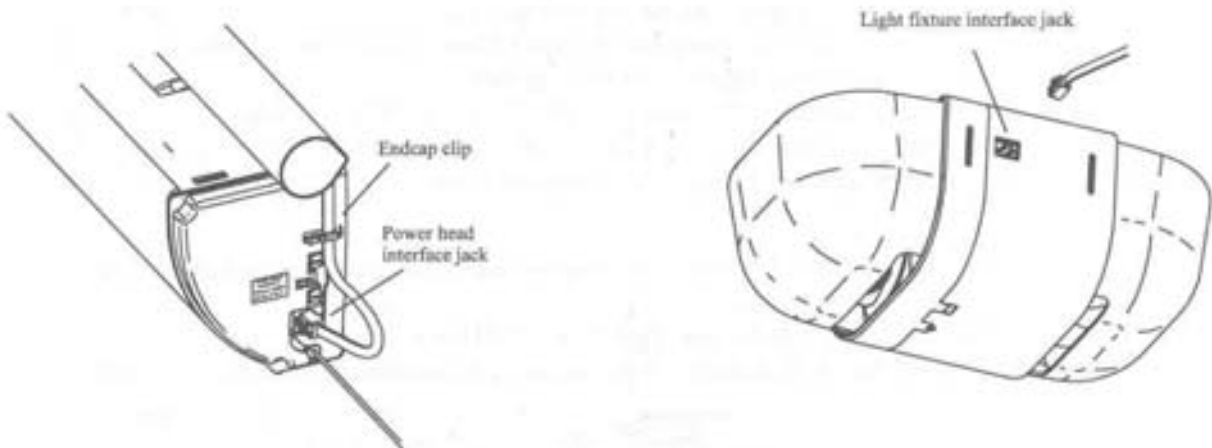

**To reduce the risk of electrical shock, connect the power cord only to a properly grounded three prong, 120 Volt outlet. Do not use an extension cord or change the plug in any way.**

Plug light fixture into electrical outlet. As soon as power is applied to unit, light fixture will flash once (on, off, then on for five minutes) indicating a successful connection has been made. If plug does not fit into outlet, contact a qualified electrician to install proper outlet.

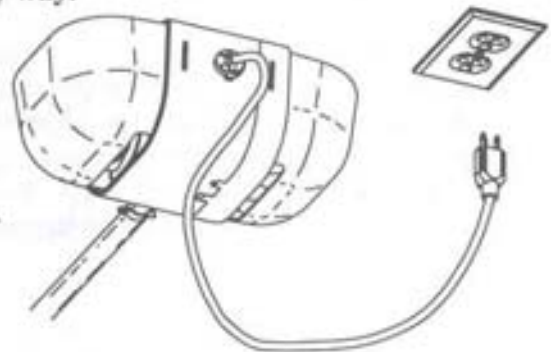

## 10

## Control Programming

The wall station and transmitter controls are programmed to match the operator at the factory and require no additional programming. If replacement or accessory controls have been purchased or custom transmitter button settings are desired, the controls will need to be programmed.

### Wall Station Programming

To verify that the wall station is matched to the operator, press the wall station up/down button. The light fixture will flash one time to indicate a matched control, and wall station programming is not required. If instead, light fixture LED blinks rapidly while holding the wall station up/down button, the wall station needs to be programmed.

#### To program the wall station:

- 1) Press the light fixture program button; light fixture LED will light.
- 2) Press and release wall station up/down button; light fixture LED will turn off.
- 3) Press and release wall station up/down button again; light fixture LED will light briefly, then turn off.

Wall station is now programmed.

Rapid light fixture LED blinking with no pause indicates a programming failure.

Repeat steps 1-3.

NOTE: Programming failure can occur if the wall station is too close to the light fixture during the programming sequence. Perform programming with a minimum 6 feet distance between wall station and light fixture.



### Transmitter Programming

To verify that the transmitter is matched to the operator, press the large transmitter button. The light fixture will flash one time to indicate a matched control. If instead, the light fixture LED blinks rapidly while holding down the large transmitter button, the transmitter needs to be programmed.

NOTE: Only the large transmitter button is pre-programmed. Any of the three transmitter buttons can be programmed to activate the door. In multi-door installations, each button or a combination of two buttons pushed at the same time can be programmed to activate a separate door.

#### To program the Transmitter:

- 1) Press program button on light fixture OR transmitter program button on wall station; light fixture LED will light.
- 2) Press and release the desired transmitter button; light fixture LED will turn off.
- 3) Press and release same transmitter button again; light fixture LED will light briefly, then turn off.

Transmitter is now programmed.

Rapid light fixture LED blinking with no pause indicates a programming failure.

Repeat steps 1-3.

NOTE: Programming failure can occur if the transmitter is too close to the light fixture during the programming sequence. Perform programming with a minimum 6 feet distance between transmitter and light fixture.

NOTE: The operator can be activated by up to six remote control devices (including wall station and keyless entry controls). If a seventh control is programmed, one of the programmed controls will be overwritten and will no longer activate the operator. To clear the programming of all remote control devices, press and hold the light fixture program button for approximately ten seconds. When the light fixture LED goes out, all controls are erased.



# 11 Install Routine

Model BIRW-2000 Only!



**IMPORTANT:** This infrared beam sensor sends an invisible beam of light from the sending unit to the receiving unit across the pathway of the door. The door operator will not operate until the beam sensor is connected to the power unit and properly aligned. If the invisible beam of light is obstructed, an open door cannot be closed by the transmitter or a momentary activation of the wall mounted push button. However, the door may be closed by holding your finger on the wall push button (constant pressure) until the door starts and continues to travel to a fully closed position.

Prior to install routine, photo sensors must be aligned. Beam sensors must be aligned by moving sending and receiving units in or out (see Figure 1) until alignment light on receiving unit comes on. Carriage bolts can be loosened to move units in or out, as required. If you have difficulty aligning beams, check that both brackets are mounted at same height and remount if necessary. Additional minor adjustments can be made by lightly bending mounting brackets (see Figure 2).

Once the alignment light comes on, tighten all bolts and mounting screws.

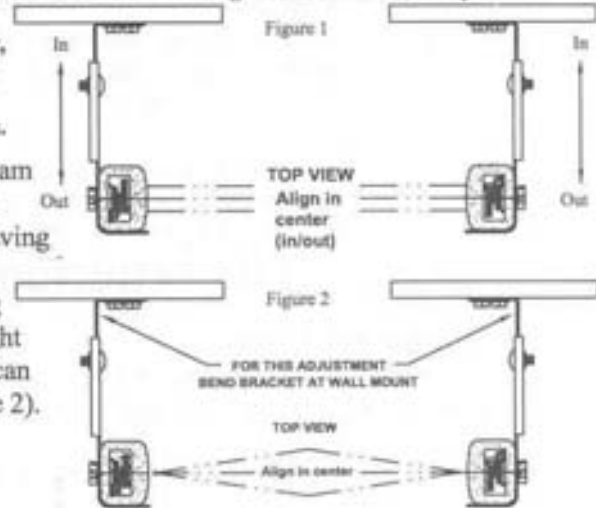

**WARNING:** During the install routine, the door will move up and down twice. Always keep a moving door in sight and away from people and objects until it is completely closed. **NO ONE SHOULD CROSS THE PATH OF A MOVING DOOR!**

Disengage emergency disconnect. Manually raise door to full open position. Then, lower door to full closed position to verify freedom of movement.

Re-engage emergency disconnect with door in fully closed position.

Door must be in fully closed position to initiate Install Routine!

Insert programming tool or similar object (paper clip, etc..) into hole in center of wall station and depress internal switch. Light fixture will flash twice indicating activation of install routine. Door will move to full open position and stop. Then, door will close completely. Next, door will go through one more up/down cycle. Once this is complete, door limits are set and installation is complete.

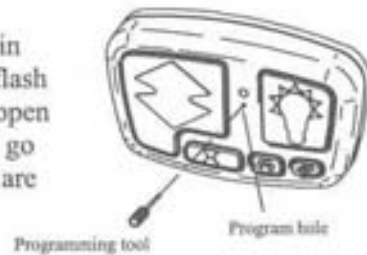
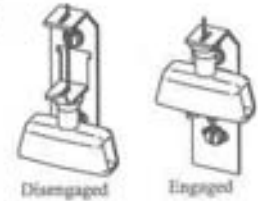

### Custom Upper Limit Setting

Custom upper limit may be set by the following procedure:

With the door in the full down position, press the install switch on the wall station with the programming tool. When the door is at the desired up position, at least four feet off the ground, press the up/down button on the wall station. The door will reverse and then continue through its normal installation routine with custom up position.

### Custom Pet Position

Normal install routine sets pet open height to approximately six inches above floor. Pet opening height may be changed to open anywhere between one inch and one foot above floor. To change automatic pet opening height perform the following procedure:

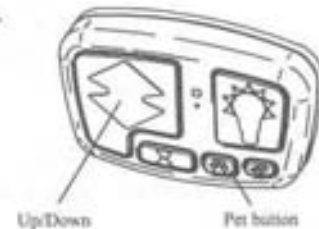

1.) After completion of normal Install routine, with door in the closed position, disconnect door from power head using emergency disconnect. Manually lift door to height more than one foot above floor. (Motor will start at one inch and stop above seven inches.) Manually lower door to desired pet position opening height and re-engage emergency disconnect.

2.) Simultaneously depress pet button and up/down button on wall station. Light fixture will flash once. The pet button is now programmed to automatically open the door to this custom height.

NOTE: Activation of the normal install routine always sets pet position opening to default 6" height. For usage of pet button feature see Operation.

NOTE: If light fixture does not flash, the door is too low, too high, or dual button activation was not simultaneous. Place door between 1" and 12" off the ground and repeat step 2.

## 12 Contact Obstruction Test

(Model: BDOR-2000/BIRW-2000)

After installing opener, door must reverse when it contacts a 1-1/2 inch high object (or a 2 x 4 board laid flat) on the floor. To verify proper operation:

- Activate door to fully open position by pressing wall station up/down button.
- Place a 2 x 4 board laid flat on garage floor under path of door (as illustrated).
- Activate door to closed position by pressing wall station up/down button; Upon contacting a solid object, the door should stop, then reverse direction within (2) seconds and travel to full open position.

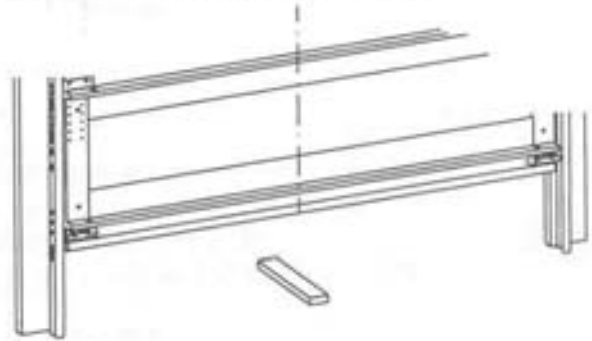

**NOTE: If opener fails to pass this test, repeat Install Routine making sure door is in the fully closed position before beginning routine. If problem persists contact Wayne Dalton Customer Service.**

(Model: BIRW-2000 Only)

After installing opener, door must reverse when photo beam sensor is blocked by a 6" x 12" object placed in door opening. To verify proper operation:

- Activate door to fully open position by pressing wall station up/down button.
- Place a 6" x 12" object on the floor progressively one foot from the left side of the door; center of door and one foot from right side of door (as illustrated).
- Activate door to closed position by pressing wall station up/down button; door should move approximately one foot, stop and then reverse to fully open position.

If the door does not respond properly to this test, the photoelectric sensors must be adjusted (refer to Step 12). Repeat this test procedure.

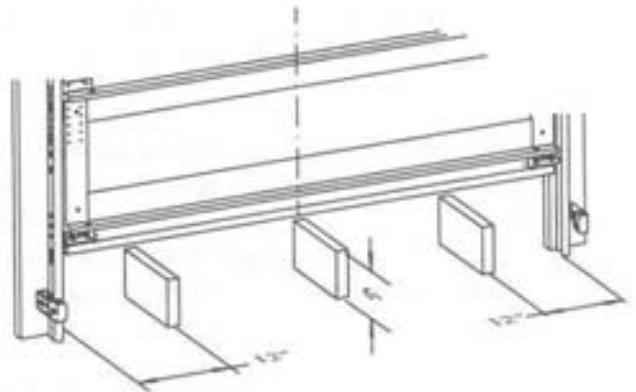

**If the door opener will not respond properly and fails this test, the door may cause severe injury or death; Have a qualified service person make repairs.**

# Operation

## IMPORTANT SAFETY INSTRUCTIONS

**WARNING** - To reduce the risk of severe injury or death:

1. READ AND FOLLOW ALL INSTRUCTIONS.
2. Never let children operate or play with door controls. Keep remote controls away from children.
3. Always keep moving door in sight and away from people and objects until it is completely closed.  
**NO ONE SHOULD CROSS THE PATH OF THE MOVING DOOR.**
4. Test door operator monthly. The garage door **MUST** reverse on contact with a 1-1/2 inch high object (or a 2 x 4 board laid flat) on the floor. After adjusting the limit of travel, retest the door. Failure to adjust operator properly may cause severe injury or death.
5. For products having an emergency disconnect, when possible, use the emergency disconnect only when the door is closed. Use caution when using the release with the door open. Weak or broken springs may allow the door to fall rapidly, causing severe injury or death.
6. **KEEP GARAGE DOOR PROPERLY BALANCED.** See owner's manual. An improperly balanced door could cause severe injury or death. Have a qualified service person make repairs to cables, spring assemblies, and other hardware.
7. **SAVE THESE INSTRUCTIONS.**

### Door Activation

Upon activation by either wall station or transmitter, door will move in following manner:

1. If closed, door will open. If open, door will close.
2. If closing, door will stop, reverse, and return to open position. Next activation will close.
3. If opening, door will stop. Next activation will close.
4. If an obstruction is encountered or an out of balance condition is detected while closing, door will reverse, return to open position, and light fixture will flash three times. Next activation will close door.
5. If an obstruction is encountered or an out of balance condition is detected while opening, door will stop, and light fixture will flash three or four times. Next activation will close door.



**Never let children operate or play with door controls. Keep remote controls away from children. Fatal injury could result should a child become trapped between the door and the floor.**



**Always keep moving door in sight and away from people and objects until it is completely closed. To prevent serious injury or death, avoid standing in the open doorway or walking through the doorway while door is moving.**

## WALL STATION OPERATION

Momentarily pressing the **Up/Down button** activates the door. If a small out of balance condition causes the door to stop while opening or reverse while closing, applying constant pressure on the Up/Down button will allow the operator to move the door in this condition until the problem is corrected. See Troubleshooting Section.

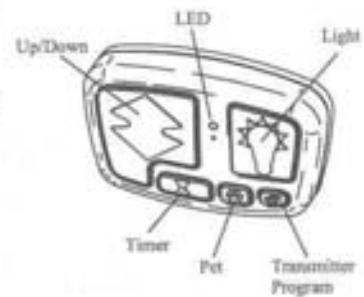

If a gross out of balance condition causes the door to stop while opening, applying constant pressure on the Up/Down button will allow the operator to move the door up. This process can be repeated to open a door in this condition but the problem must be corrected. See Troubleshooting Section.

If a gross out of balance condition causes the door to stop while closing, the out of balance condition **MUST** be corrected before the door can be lowered by the operator. Constant pressure on the Up/Down button will not allow the door to be lowered in this condition. See Troubleshooting Section.

**WARNING! Manually lower the door by back-driving; See MANUAL DOOR OPERATION - Back-driving. Avoid using the emergency disconnect to lower door. Weak or broken springs may allow the door to fall rapidly, causing severe injury or death.**

Momentarily pressing the **light button** turns on the light fixture. The light fixture will remain on until either the light button is pressed again or the door is activated. The light fixture automatically turns on with door activation and remains on for 5 minutes thereafter. Pressing the light fixture button before the 5 minutes has elapsed will turn off the light fixture.

Momentarily pressing the **timer button** causes delayed activation of a stationary fully open door. The light fixture will flash for 8 seconds then stay constantly lit for 2 seconds prior to activating door. Allow enough time to exit the garage. Pressing any button, except for the program button while the light fixture is flashing cancels timer mode. **NOTE:** Timer feature will only function with door in fully open position. Pressing the timer button with a stationary door in any other position will cause the light fixture to flash four times and the door will not be activated. While the door is in motion, the timer button functions identically to the Up/Down button, stopping or reversing the door immediately.

Pressing the **pet button** activates a closed door and causes it to open to a position between 1 and 12 inches above the floor, allowing pets to enter and exit the garage without the door being fully open. Next door activation will cause the door to open. The pet feature will only function with the door in the fully closed position. Pressing the pet button with a stationary door in any other position will cause the light fixture to flash five times and the door will not be activated. While the door is in motion, the pet button functions identically to the Up/Down button stopping or reversing the door immediately. The pet feature allows for custom setting of the pet position door height. See Install Routine.

**NOTICE:** A door in the "pet position" (open 2" - 12") is not locked and should not be used as a secured door position. The DoorMaster automatic lock feature is functional only on a fully closed door.

The **transmitter program button** allows for custom programming of the transmitter controls or the addition of extra transmitter controls. See Transmitter Programming.

The wall station **LED** will light while any wall station button remains pressed. Rapid LED flashing while any wall station button is pressed indicates a weak wall station battery. See Maintenance section for battery replacement.

**TRANSMITTER OPERATION**

Momentarily pressing button programmed in Step 10 activates door. Small transmitter buttons can also be programmed to activate door, or in multi-door installations, each door or a combination of two buttons pushed together can be programmed to activate a different door. See [Transmitter Programming](#) for instructions.

The transmitter LED will light while any transmitter button remains pressed. Rapid LED flashing while any transmitter button is pressed indicates a weak transmitter battery. See [Maintenance Section](#) for battery replacement.



**Test operator monthly. The garage door MUST reverse on contact with a 1-1/2 inch object (or a 2 x 4 board laid flat) on the floor. After adjusting the limit of travel, retest the door operator. Failure to adjust the operator properly may cause severe injury or death.**



**KEEP GARAGE DOOR PROPERLY BALANCED. See owner's manual. An improperly balanced door could cause severe injury or death. Have a qualified service person make repairs to cables, spring assemblies, and other hardware.**

**MANUAL DOOR OPERATION - Back-driving**

**NOTE:** For security reasons, operator will automatically push door down if an attempt is made to manually raise door from a fully closed position, so always use emergency disconnect to manually raise door from closed position.

The operator's high efficiency drive system allows door to be moved manually without disconnecting operator from door. To move door manually, apply a steady upward or downward force of approximately forty pounds directly to stationary door to move door to desired position.

**MANUAL DOOR OPERATION - Emergency Disconnect**

**The Emergency Disconnect should only be used when the door is closed. Do NOT use the Emergency Disconnect on an open door. Weak or broken springs may allow the door to fall rapidly, causing severe injury or death.**

The operator is equipped with an emergency disconnect that allows door to be moved manually and independent from the operator. With door closed, pull on red disconnect handle, sliding handle underneath lower fork on handle bracket. This motion causes power head to disconnect from torque tube. Releasing handle from lower fork on handle bracket, releasing cable tension, causes power head to engage torque tube. When engaged, door can be moved manually by back-driving or automatically with wall station or transmitter controls.

**NOTE:** For security reasons, operator will attempt to push door down anytime door is moved manually from a closed position. With emergency disconnect disengaged, operator motor will run but not push the door once door is raised above two inches. The operator motor will stop once door is raised above seven inches. After this sequence, once disconnect is re-engaged, door will have to operated for at least one partial open and close cycle to reactivate security features.

# Maintenance

## MONTHLY MAINTENANCE

- A. Manually operate door with emergency disconnect disengaged. If door is unbalanced or binding have a qualified service person repair or adjust door.
- B. Perform contact obstruction test (See section 12).  
Perform photo beam sensor test for model BIRW-2000 (See section 12).

## ANNUAL MAINTENANCE

Refer to garage door owner's manual for annual door maintenance.

## BATTERY REPLACEMENT

Inability to activate door from transmitter or wall station may be caused by a weak or dead battery. Press and hold activation button on either transmitter or wall station. Rapid blinking or no signal from the transmitter or wall station LED indicates a weak or dead battery.

Insert coin in slot in transmitter or wall station as illustrated and twist coin to reveal battery. Replace battery, being careful to match positive (+) symbol on circuit board with positive (+) symbol on battery.

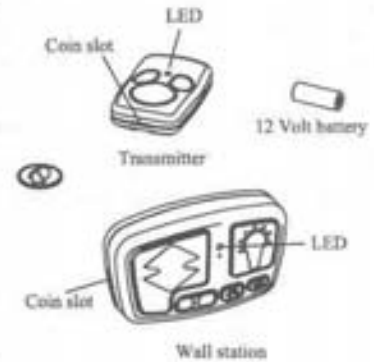

## NOTE: USE ONLY MN21 OR EQUIV. 12 VOLT BATTERY.

If light fixture blinks once at beginning and end of a door cycle, batteries in power head are low. This will occur if operator loses power for an extended period of time or unit was operated severely. In this case let batteries charge overnight to see if problem goes away. If problem persists, replace batteries. To remove batteries, disengage emergency disconnect. Remove left hand endcap by pressing in on bottom snap and pulling out endcap. Pull battery wiring out of housing and disconnect. Pull battery pack from power head and replace with new battery pack. Reconnect and tuck battery wiring into power head and reinstall endcap. Engage emergency disconnect.

**WARNING! Batteries contain lead. Do not throw in trash. recycle batteries. Call 1-800-SAV-LEAD for a recycle location near you.**

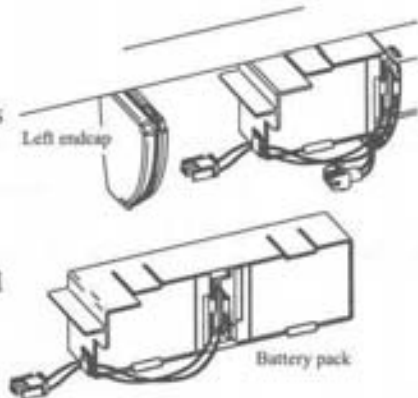



# Troubleshooting

Symptom	Probable Cause	Corrective Action
Operator does not respond to wall station or transmitter	No power to operator	Check light fixture cord to outlet circuit breaker, battery connections, battery condition
	Controls not programmed	See Programming Section
Operator works from wall station but not from transmitter	Transmitter not programmed	See Programming section
	Weak/dead transmitter battery	Replace battery
Operator works from transmitter but not from wall station	Wall station not programmed	See Programming section
	Weak/dead wall station battery	Replace battery
Door does not move and light fixture flashes one time	Install Routine not yet complete	Complete Install Routine
Door does not move and light fixture flashes 4 times	Blown fuse	Call service professional
	No battery power to motor	Reconnect, recharge, or replace battery
Door stops or reverses, light fixture flashes three or four times	Obstruction encountered	Clear door path
Door does not close properly	Cables not on drum properly	Press and hold down up/down button or use emergency disconnect and close manually
Door will not close	Thermal Delay: Door has cycled eight times in a five minute period	Door will operate after a one minute waiting period
	Obstruction Test failure	Repeat Install Routine
Door does not travel to full open or full closed position	Door out of balance	Correct door balance
	Limits improperly set	Repeat Install Routine
Door not sealing on floor	Bottom limit set too high	With door closed, force door tighter against floor by rotating Torquemaster spring tube. Repeat Install Routine
Light fixture flashes continuously at end of close or open cycle and operator will not respond to start command	"Frozen relay" test error	Re-set by unplugging light fixture AC power and battery pack, then re-connect

# Service Parts

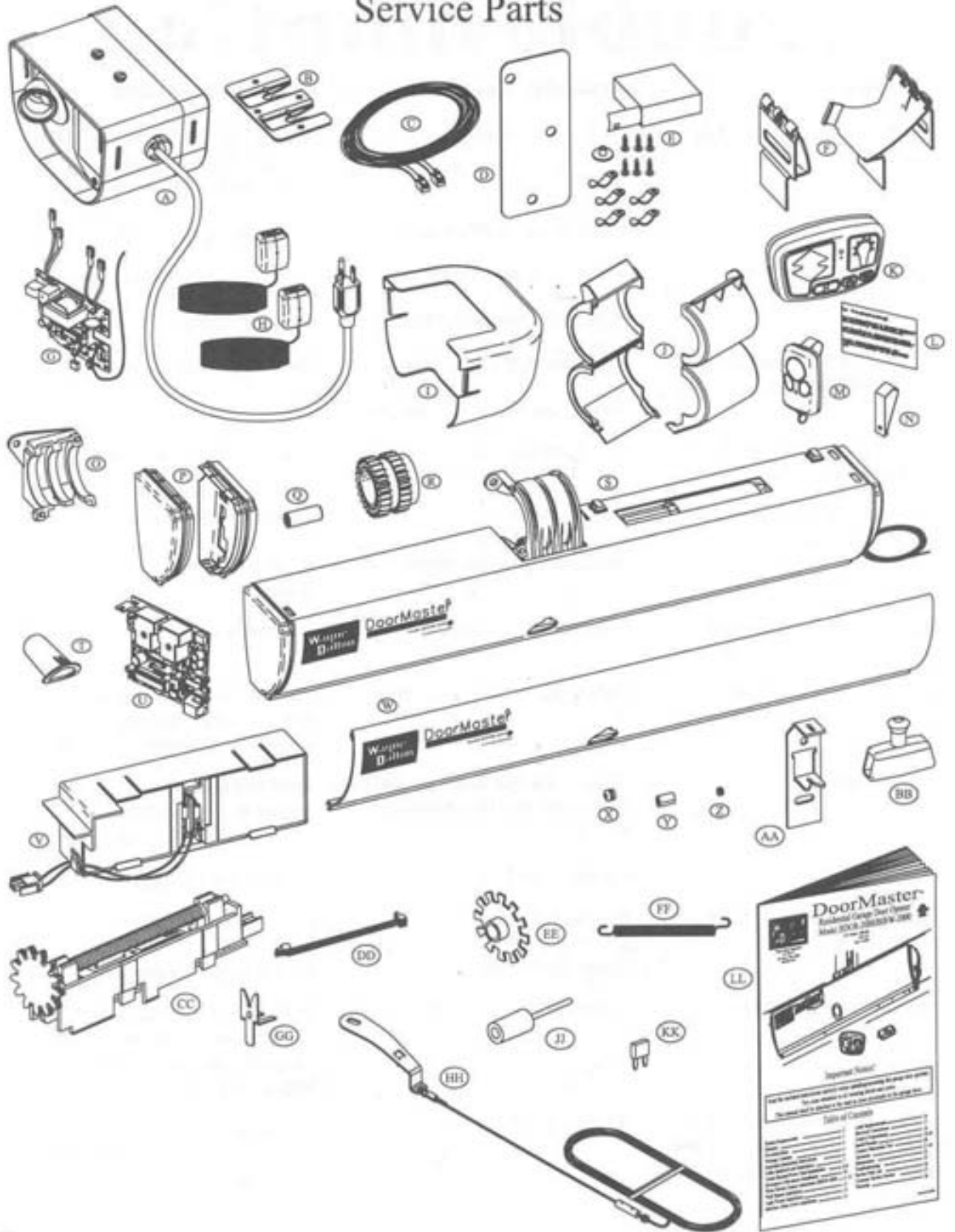

## Service Parts Part Numbers

- (A) Light Fixture - P/N = BDOR 284724; BIRW 285349
- (B) Light Fixture Mounting Plate - P/N 274143
- (C) Interface Cable - P/N = 279996 (15'); 285651 (25')
- (D) Drywall Adapter - P/N 284455
- (E) Interface Cable Cover Kit - P/N 287176
- (F) Lock - P/N = Right 284733; Left 284732
- (G) Light Fixture Circuit Board - P/N 283894
- (H) Photoelectric Sensors Set - P/N 251245
- (I) Diffuser - P/N 271390
- (J) Snubber Wrap - P/N = Right 288821; Left 288820
- (K) Wall Station Transmitter - P/N 285327
- (L) Reference Card - P/N 279993
- (M) Remote Transmitter - P/N 285254
- (N) Visor Clip - P/N 274135
- (O) Center Bracket - P/N 263106
- (P) Endcap - P/N = Right 284717; Left 274133
- (Q) 12 Volt Transmitter Battery - P/N 270802
- (R) Driven Gear - P/N 269030
- (S) Power Head (less batteries) - P/N = BDOR 287220; BIRW 287221
- (T) Screw Cover - P/N 274144
- (U) Motor Control Circuit Board - P/N = BDOR 283896; BIRW 285344
- (V) Battery Pack - P/N 285334
- (W) Cover - P/N = BDOR 284652; BIRW 285345
- (X) Grommet - P/N 279173
- (Y) Cable Sleeve - P/N 284718
- (Z) Cable Bushing - P/N 284441
- (AA) Handle Bracket - P/N 279172
- (BB) Disconnect Handle - P/N 284453
- (CC) Potentiometer Assembly - P/N 284723
- (DD) Potentiometer Wiring Harness - P/N 284446
- (EE) Encoder Wheel - P/N 274147
- (FF) Disconnect Spring - P/N 279982
- (GG) Cable Clip - P/N 283846
- (HH) Disconnect Cable Assembly - P/N 279983
- (JJ) Programming Tool, Wall Station - P/N 279994
- (KK) Fuse - P/N 288819
- (LL) Owners Manual - P/N 284457

### Questions?

**For quick answers &  
helpful advice, call**

**Customer Service Pensacola**

**(800) 305-4349**

**or**

**(800) 676-7734**



Wayne Dalton Corporation  
P.O. Box 67 • Mt. Hope, Ohio 44660

# DoorMaster™

## Model BDOR-2000

## Model BIRW-2000

### LIFETIME LIMITED WARRANTY

The Manufacturer warrants that its garage door opener will be free from defects in materials and workmanship for a period of **FIFTEEN YEARS** from the date of installation, provided it is properly maintained and cared for under normal use and service. Electronic components are covered under this warranty a period of **FIVE YEARS**. The motor has an extended **LIFETIME** warranty against defects in materials and workmanship.

This Warranty extends to the original homeowner, providing the garage door opener is installed in his/her place of primary residence. It is not transferable. The warranty applies to residential property only and is not valid on commercial or rental property.

**NO EMPLOYEE, DISTRIBUTOR, OR REPRESENTATIVE IS AUTHORIZED TO CHANGE THE FOREGOING WARRANTIES IN ANY WAY OR GRANT ANY OTHER WARRANTY ON BEHALF OF MANUFACTURER.**

The Manufacturer shall not be responsible for any damage resulting to or caused by its products by reason of installation, improper storage, unauthorized service, alteration of products, neglect or abuse, any acts of nature beyond Manufacturer's control (such as, but not limited to, lightning, power surges, water damage, etc.), or attempt to use the products for other than the customary usage or for their intended purposes. The above warranty does not cover normal wear or any damage beyond Manufacturer's control or replacement labor.

**THIS WARRANTY COVERS A CONSUMER PRODUCT AS DEFINED BY THE HAGNUSON-MOSS WARRANTY ACT. NO WARRANTIES, EXPRESSED OR IMPLIED, (INCLUDING, BUT NOT LIMITED TO, THE WARRANTY OF MERCHANTABILITY OR FITNESS FOR A PARTICULAR PURPOSE), SHALL EXTEND BEYOND THE APPLICABLE TIME PERIOD STATED IN BOLD FACE TYPE ABOVE.**

Claims for defects in material and workmanship covered by this warranty shall be made in writing to the dealer from whom the product was purchased within the warranty period. Manufacturer may either send a service representative or have the product returned to the Manufacturer at Buyer's expense for inspection. If judged by Manufacturer to be defective in material or workmanship, the product will be replaced or repaired at the option of the Manufacturer, free from all charges except authorized transportation and replacement labor.

**THE REMEDIES OF BUYER SET FORTH HEREIN ARE EXCLUSIVE AND ARE IN LIEU OF ALL OTHER REMEDIES, THE LIABILITY OF MANUFACTURER, WHETHER IN CONTACT, TORT, UNDER ANY WARRANTY OR OTHERWISE, SHALL NOT EXTEND BEYOND ITS OBLIGATION TO REPAIR OR REPLACE, AT ITS OPTION, ANY PRODUCT OR PART FOUND BY MANUFACTURER TO BE DEFECTIVE IN MATERIAL OR WORK SHALL NOT BE RESPONSIBLE FOR ANY DIRECT, INDIRECT, SPECIAL OR CONSEQUENTIAL DAMAGES OF ANY NATURE.**

This Warranty gives you specific legal rights which may vary from state to state. However, some states do not allow limitation on how long an implied warranty lasts or the exclusion or limitation of incidental or consequential damages so the above limitations or exclusions may not apply to you.

		C:\Software\Documents\Transmitter Programming Procedure.doc	
Spec. No.: TBD	Product No.: TBD	Originated: 10/7/2001	
<b>Manual Update Document</b> Wayne-Dalton Corp. Pensacola, FL			
<b>Transmitter Programming Procedure</b>			
Author: Richard Gagnon	R&D Approved:	Revised: 10/7/2001	
Mfg. Approved:	QA Approved:	Revision: 1	

PRELIMINARY

**1. Purpose**

Provide instructions to reprogram the serial number for the portable transmitter and wall station.

**2. Portable Transmitter**

- 2.1. Insert coin in slot in transmitter, twist coin to remove cover.
- 2.2. Locate buttons S4 (UCC) and S3.
- 2.3. Start by pressing and holding button S4, then pressing and holding button S3.
- 2.4. Continue holding the buttons until the light begins to flash (about 3 seconds)
- 2.5. Release the buttons.
- 2.6. A new serial number is now programmed into the transmitter.
- 2.7. Replace cover.
- 2.8. Refer to section ?? to relearn the operator to recognize the transmitter.

**3. Wall Station**

- 3.1. Insert coin in slot in wall station, twist coin to remove cover.
- 3.2. Locate button SW7 (UCC).
- 3.3. Press and hold button SW7 until the light begins to flash (about 3 seconds)
- 3.4. Release the button.
- 3.5. A new serial number is now programmed into the wall station.
- 3.6. Replace cover.
- 3.7. Refer to section ?? to relearn the operator to recognize the wall station

**4. Revision History**

Date	Change Description	Rev.	By
10/08/01	Originated	1	REG