

SECTION 6  
USER'S MANUAL

01-0103  
01-0104



Wayne Dalton Corporation  
P.O. Box 57  
Mt. Hope, Ohio 44660  
800.305.4349

# DoorMaster

Residential Garage Door Opener  
Model BDOR-2000/BIRW-2000



U.S. Patents: 5,929,580  
5,931,212  
Des. 413,055

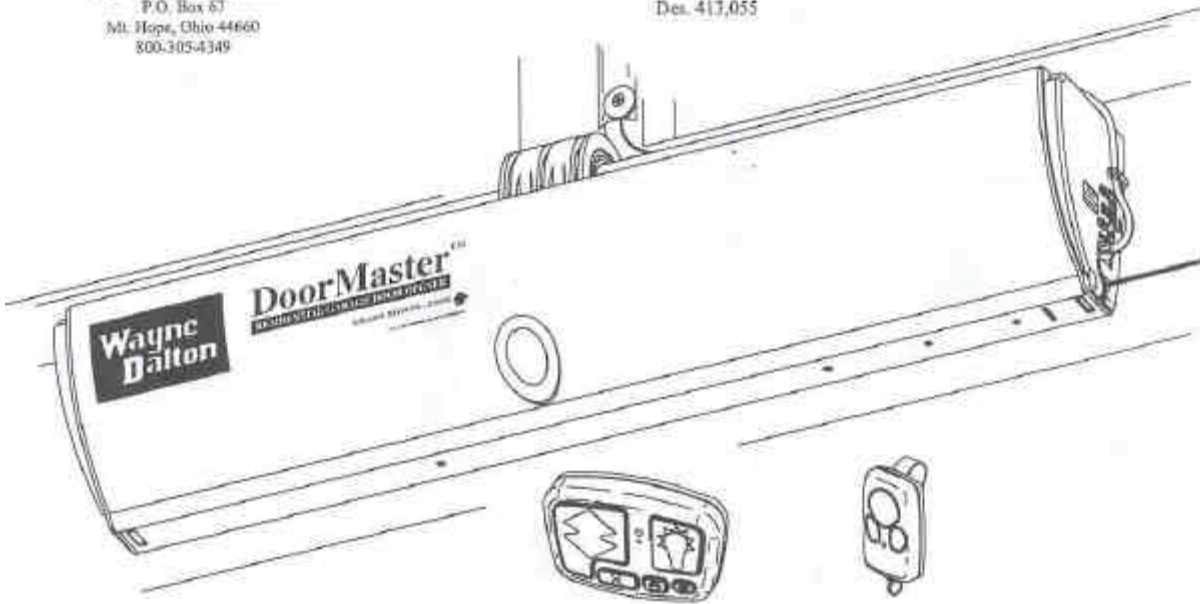

## Important Notice!

Read the enclosed instructions carefully before installing/operating this garage door operator.  
Pay close attention to all warning labels and notes.  
This manual must be attached to the wall in close proximity to the garage door.

## Table of Contents

<b>System Requirements</b> .....	2	<b>Label Placements</b> .....	16
<b>Features</b> .....	3	<b>Electrical Connections</b> .....	17
<b>Pre-Installation</b> .....	4	<b>Control Programming</b> .....	18
<b>Package Contents</b> .....	5	<b>Install Routine</b> .....	19
<b>Important Installation Instructions</b> .....	6	<b>Contact Obstruction Test</b> .....	20
Cable Snubber Wrap and Lock Installation .....	7	<b>Operation</b> .....	21
Center Bracket/Power Head Installation .....	8	<b>Maintenance</b> .....	24
Emergency Disconnect Installation .....	10	<b>Troubleshooting</b> .....	25
Photo Electric Sensor Installation (BIRW-2000) .....	11	<b>Service Parts List</b> .....	26
Wall Station Installation .....	13	<b>Customer Service Number</b> .....	27
Light Fixture Installation .....	14	<b>Warranty</b> .....	28
Interface Cable Cover Installation .....	15	<b>Appendix</b> .....	29

# System Requirements

**⚠ WARNING!** To reduce the risk of injury, use operator only with the following doors.

- Model BDOR-2000 will work with any WayneGard™ series door utilizing 12" radius track and a TorqueMaster™ Counterbalance System.
- Model BIRW-2000 will work with any Wayne Dalton® residential door system utilizing 12" radius track and a TorqueMaster™ Counterbalance System.

NOTE: 1. If your Wayne Dalton® door was manufactured before July 1, 1999, it may be necessary to obtain and install a Wayne Dalton TorqueMaster™ retrofit kit for Model BDOR-2000/BIRW-2000 operator. Compatible TorqueMaster™ end brackets, driven gear, and flag angles must all be present.  
 2. New drums (date stamp 2000+) are required for the new drum cover "Snubber Wrap". Retrofit kits manufactured after 6/1/2000 contain the new drums.

Refer to illustrations below to determine retrofit kit requirements.

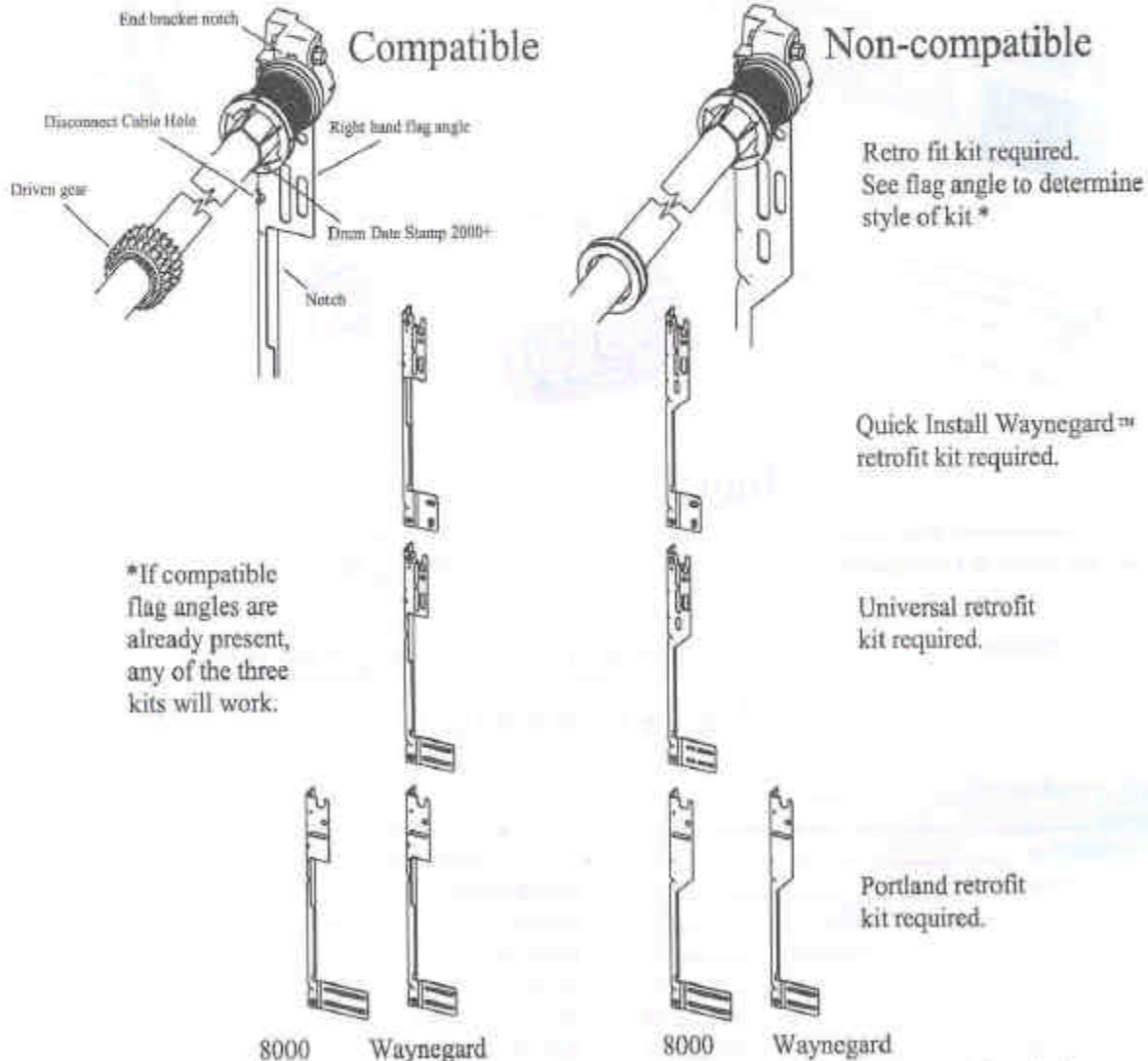

3. When installing a DoorMaster on a retrofit installation, verify the vertical track distance from the bottom of the header to the top of the vertical (track splice) is 8". Some old track has a 9" space here and will require raising the track 1" to clear DoorMaster.

# Features

## High Efficiency Motor and Drive Train Enclosed in Unique Header Mounted Case

- Requires no headroom beyond counterbalance system,
- Battery powered. Fully functional during power outages!
- Advanced electronics provide continuous monitoring of door forces and automatically stops or reverses door due to obstruction or out of balance condition.

## Deluxe Wall Station Control

- Oversized Up/Down button for easy opening and closing of garage door.
- Oversized light button for manual control of light fixture.
- Timer button for delayed door closing operation allowing user time to exit through door prior to door closing.
- Pet button automatically sets door to a slightly open position for pet access or ventilation.
- Transmitter program button allows convenient programming of remote controls.
- Convenient "one touch" limit setting.
- Wireless mounting for easy installation and clean appearance.

## Deluxe Remote Control Transmitter

- Three buttons for use with up to six separate doors.
- Secure Rolling Code: Eliminate remote door activation by would-be intruders.
- Convenient key chain or visor mounting.

## Deluxe Two Bulb Light Fixture

- Provides safety and automatic convenience light during door operation and remains on for five minutes after door motion stops.
- Can be operated independently from door operation using Wall Station Control.
- Provides signals to warn user of safety or operational problems.

## Emergency Disconnect

- Allows door to be operated manually to verify and maintain proper door balance.

## Available Accessories

- Photo electric non-contact obstruction sensor - Wayne Dalton® Model No. ML2 Model BDOR Accessory (Required on Model BIRW-2000) - P/N 285338
- Keyless entry system - Wayne Dalton® Model No. KEP1-0000 - P/N 285247  
Wayne Dalton® Model No. KEP2-0000 - P/N 288830
- Longer (25 ft) Interface Cable - P/N 285652
- Additional Remote Transmitters - P/N 285254

## Pre-Installation

Model BDOR-2000/BIRW-2000 should only be installed on a properly counterbalanced, properly operating garage door. A door that binds, sticks or is out of balance could cause severe injury. Do not attempt to compensate for an improperly adjusted door by the installation of the operator. This will interfere with the proper operation of the operator and/or damage the door and/or operator. Perform the following checks:

### Garage Door

1. Fully raise and lower garage door and check for any sticking or binding that occurs. Have a qualified service person lubricate, repair, or adjust as necessary.
2. Lift garage door approximately half way open. When released, door should stay in position. If spring tension pulls door further open or door weight pulls door further down, door is not properly balanced. Refer to TorqueMaster™ owner's manual or have a qualified service person balance door.
3. When properly installed, a door should remain clear of opening when allowed to rest at it's natural, fully opened position. Refer to TorqueMaster™ owner's manual or have a qualified service person balance door.
4. Lift door to full open position. Manually rotate TorqueMaster™ torque tube to allow door to descend. If suspension cables go slack leaving door hanging in horizontal track, have a qualified service person incline horizontal track until door descends during torque tube rotation.

### Operator

Unpack and inspect carefully for any possible shipping damage or missing parts. Refer to illustration on page five. Do not attempt installation if any parts are damaged or missing.

In order to prevent binding of the torque tube with the power head, the shipping carton has two alignment spacers incorporated into the two inserts for proper torque tube to power head alignment. Detach the alignment spacer from each insert. Alignment spacers will be used on Step 2, Center Bracket/Power Head Installation.

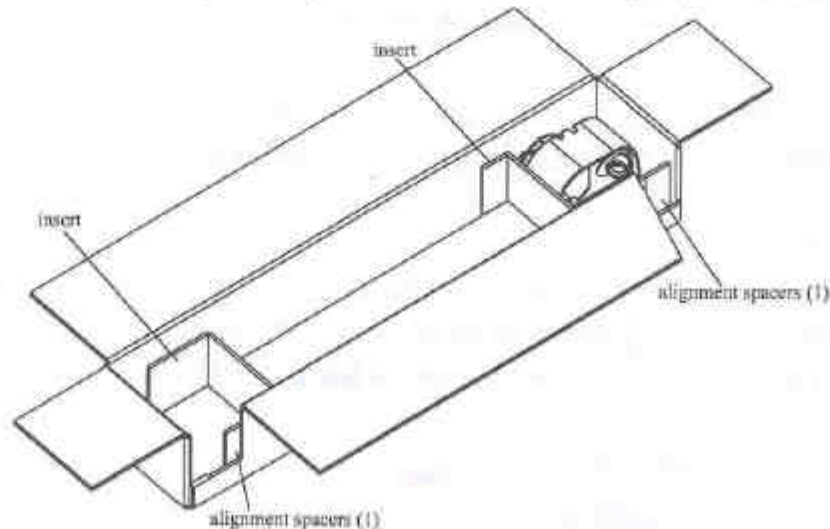

# Package Contents

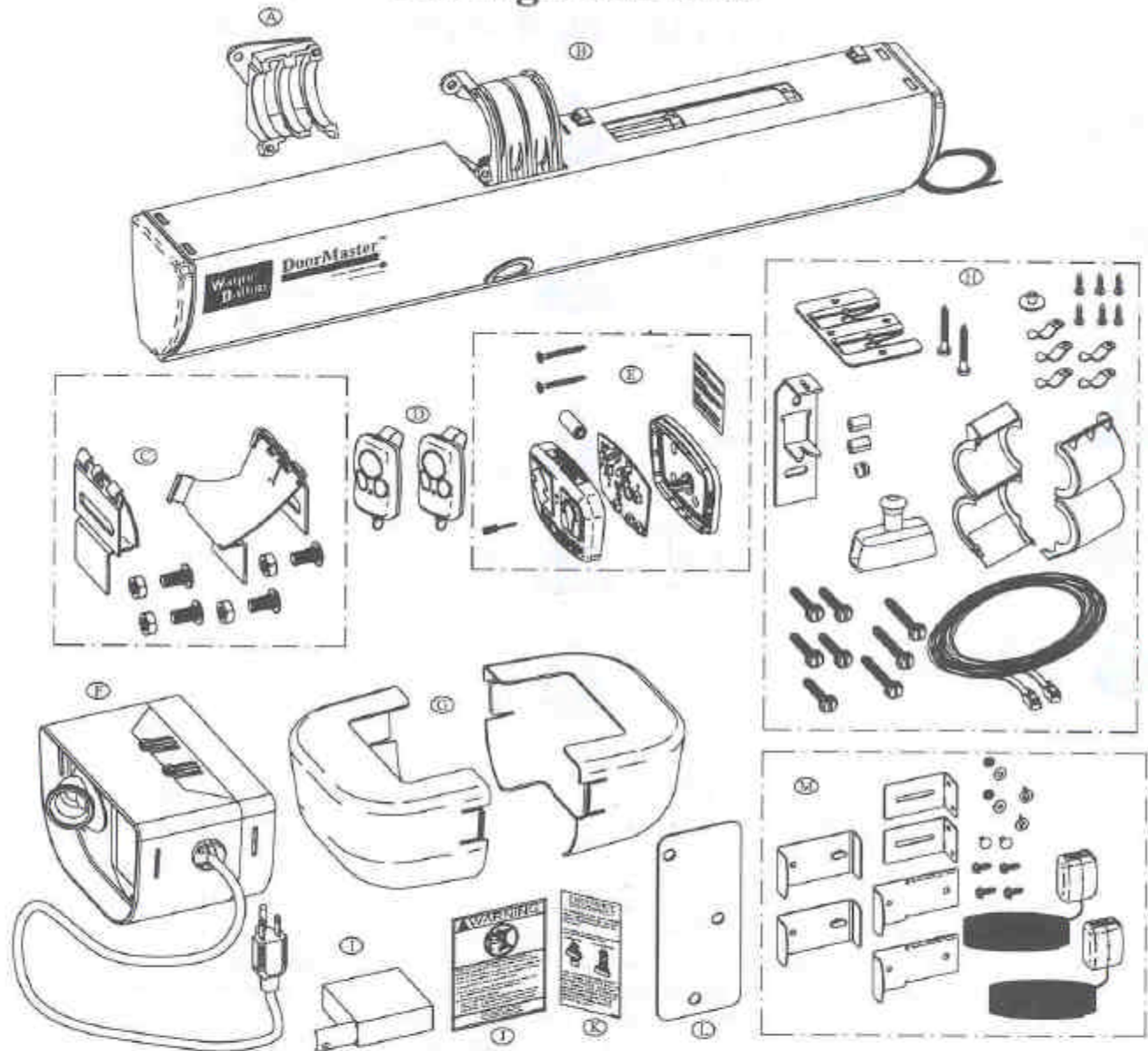

- |  |                                    |                            |
|--|------------------------------------|----------------------------|
| (A) Die Cast center Bracket [1]                  | (G) Diffusers [2]                  | (M) Photo Electric Sensors |
| (B) Power Head Unit [1]                          | (H) Hardware Pack [1] (***)        | (Model BIRW-2000) [1 set]  |
| (C) Cable Lock set (1 Right/1 Left Hand) [1] (*) | (I) Interface Cable Cover Roll [1] |                            |
| (D) Radio Transmitters (Remote Control) [2]      | (J) Entrapment Warning Label [1]   |                            |
| (E) Wall station Kit [1] (**)                    | (K) Emergency Disconnect Label [1] |                            |
| (F) Light fixture [1]                            | (L) Drywall Adapter [1]            |                            |

- (\*) (1) Left Hand Lock Assembly, (1) Right Hand Lock Assembly, (4) 3/8" Rib Neck Bolts, (4) 3/8" Nuts
- (\*\*) (1) Cover/Button Assembly, (1) Base, (1) 12 Volt Battery, (1) Reference Card, (1) Programming Tool, (1) Circuit Board, (2) #6 x 1-1/4" Wood Screws
- (\*\*\*) (5) 1/4 x 1-1/2" Lag Screws, (3) 1/4 x 2" Lag Screws, (2) #10 x 1-1/2" Wood Screws, Light Fixture Bracket, Grommet, (2) Cable Crimp Sleeve, Disconnect Handle, Snubber Wrap Set, Handle Bracket, (5) Cable Cover Clips, Cable Cover Bushing, (6) #6 x 7/8" Pan Head Screws, Interface Cable

## IMPORTANT INSTALLATION INSTRUCTIONS

### WARNING: To reduce the risk of severe injury or death:



READ AND FOLLOW ALL INSTALLATION INSTRUCTIONS.



Install only on a properly balanced garage door. An improperly balanced door could cause severe injury. Have a qualified service person make repairs to cables, spring assemblies and other hardware before installing operator.



Remove all ropes and remove or make inoperative all locks connected to the garage door before installing operator.



Where possible, install the door operator 7 feet or more above the floor. For products requiring an emergency release, mount emergency release 6 feet above the floor.



Do not connect operator to source of power until instructed to do so.



Locate the wall station: (a) within sight of door, (b) at a minimum height of 5 feet so small children can not reach it, and (c) away from all moving parts of the door.



Install entrapment warning label next to wall station in a prominent location. For products requiring an emergency disconnect, install the emergency release marking on or next to the emergency release.



After installing operator, the door must reverse when it contacts a 1-1/2 inch high object (or a 2 x 4 board laid flat) on the floor.



Do not wear rings, watches, or loose clothing when installing or servicing a garage door system.



Installing and wiring must comply with local building and electrical codes. Connect the power cord to a properly grounded outlet. Do not remove ground pin from power cord.

AFTER INSTALLATION IS COMPLETE, FASTEN THIS MANUAL NEAR GARAGE DOOR. PERFORM PERIODIC SAFETY CHECKS, MAINTENANCE AND ADJUSTMENTS, AS RECOMMENDED.

NOTE: This equipment has been tested and found to comply with the limits for a Class B digital device, pursuant to Part 15 of the FCC Rules. These limits are designed to provide reasonable protection against harmful interference in a residential installation. This equipment generates, uses and can radiate radio frequency energy and, if not installed and used in accordance with the instructions, may cause harmful interference to radio communications; However, there is no guarantee that interference will not occur in a particular installation. If this equipment does cause harmful interference to radio or television reception, which can be determined by turning the equipment off and on, the user is encouraged to try to correct the interference by one or more of the following measures: Reorient or relocate the receiving antenna. Increase the separation between the equipment and receiver. Connect the equipment into an outlet on a circuit different from that which the receiver is connected. Consult the dealer or an experienced radio/television technician for help. WARNING: Changes or modifications to this unit not expressly approved by the party responsible for compliance could void the user's authority to operate this equipment.

#### FCC/INDUSTRY CANADA REGULATORY INFORMATION

Operation is subject to the following two conditions: (1) this device may not cause interference, and (2) this device must accept any interference, including interference that may cause undesired operation of the device.

**Important!** Do not add "pre-wrap" turns of cable to the TorqueMaster drum when using the snubber wraps.

# Installation

## 1 Cable Snubber Wrap and Lock Installation

**Cable Snubber Wrap Installation** - See appendix for installation instruction of metal snubber bracket.

Locate right hand snubber. Remove the #10 self-tapping screw from the TorqueMaster end bracket, if it is installed. (1) Slide back half of snubber behind drum locating the right end wall between the drum and flag angle. (2) Close front half of snubber around drum, engage inboard snap and press firmly until a distinct snap is felt. (3) Engage outboard catch as shown. Confirm both snap and catch are fully engaged by lightly tugging against them.

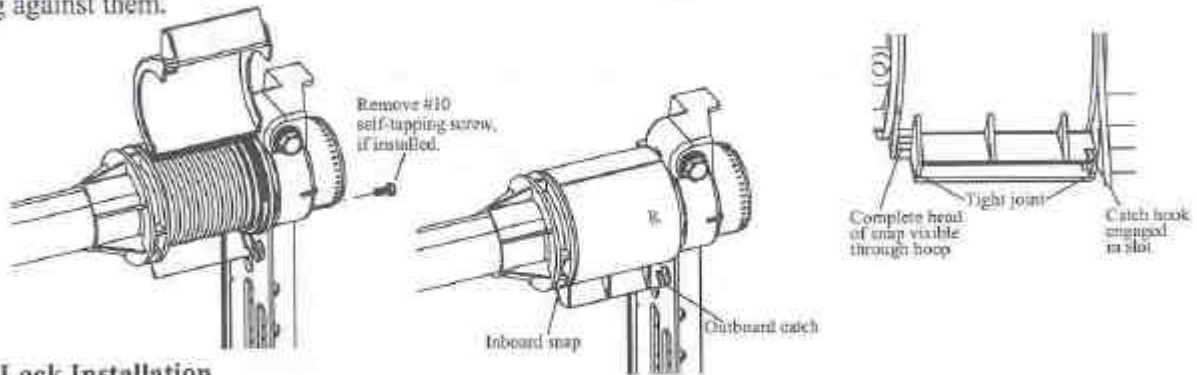

### Cable Lock Installation

Verify that horizontal angle is right side up (as shown in B, C, D). If angle is upside down (as shown in A) swap right and left hand horizontal angles.

Locate right hand cable lock components. Position lock along horizontal angle so that hook of arm will fit closely behind the door cable but not rub against back of cable. Align holes in lock with corresponding holes in horizontal angle. Once aligned, secure Lock to track using (2) 3/8" rib neck bolts and nuts (B). Lock arm should pivot freely at spring loaded hinge. Gently raise door to confirm cable lock is adjusted to stop door from opening. Cable lock's horizontal surface should come into contact with top of door and cable lock's vertical surface should be parallel with side of door. Adjust lock arm travel by bending stop tab so lock arm will not pivot beyond side of door. Pivot lock arm downwards and slide counterbalance cable in front of arm (D).

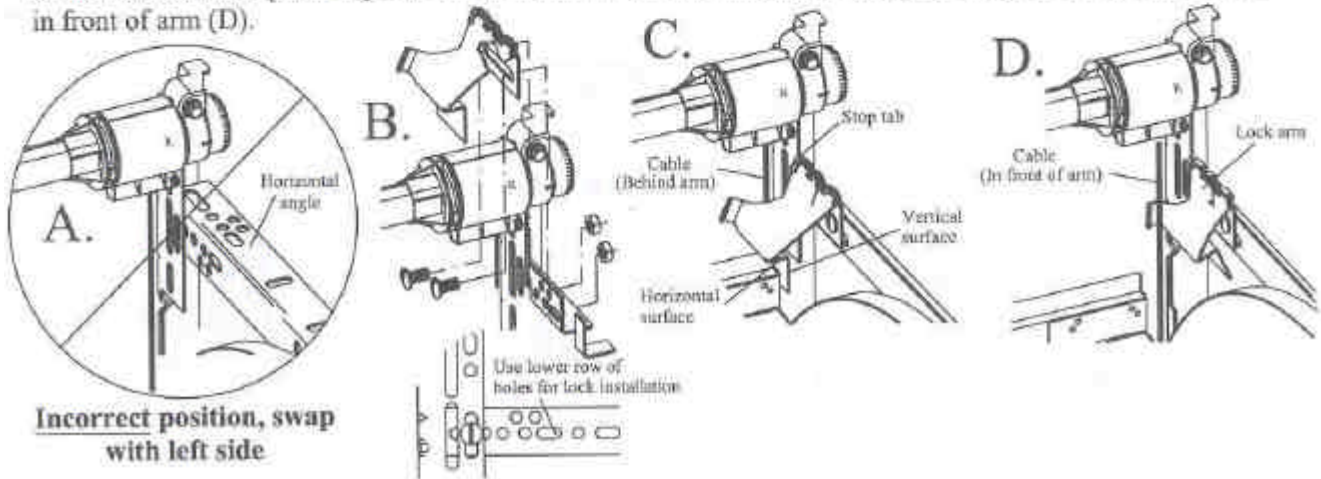

**Incorrect position, swap with left side**

Repeat Cable Snubber Wrap and Lock Installation for opposite side.



2

## Center Bracket/Power Head Installation

For operator installation, a wood anchor pad must be firmly attached to the wall, above the header board and flush with the header board at the **center** of the door section. Refer to the "Preparing The Opening" section of the "REMOVING THE OLD DOOR/PREPARING THE OPENING" Supplement Installation Instructions sheet included in the retrofit or door package for anchor pad installation.

If installing operator on a StormGard series door, operator location will vary. The power head must be mounted on torque tube so there are no obstructions between power head and right hand edge of door. Depending on StormGard door model, power head location will vary as illustrated.

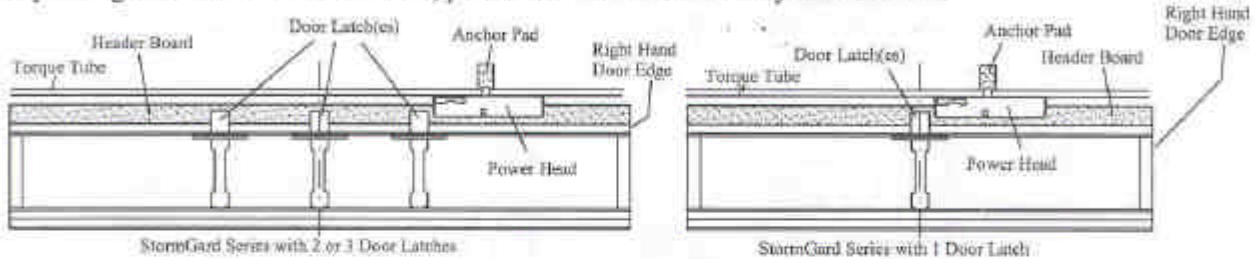

### Center Bracket

Bend tab out of way as shown. Remove (2) lag screws from TorqueMaster center bracket and remove bracket.

**NOTE: Do not discard if installing on a StormGard door with 2 or 3 door latches.**

**StormGard doors w/2 or 3 door latches only:** Stamped center bracket will be reused with TorqueMaster center bushing. Install stamped center bracket onto bushing in reverse order of removing bracket and gear.

Mount center bracket and bushing centrally on torque tube between operator and left door edge as illustrated. **NOTE:** A second anchor pad for TorqueMaster bracket may be needed for proper mounting.

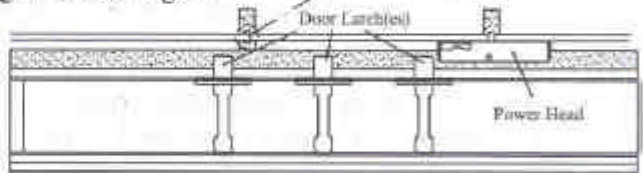
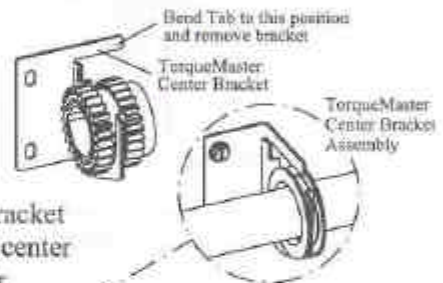

**IMPORTANT: The anchor pad and header board must be flush to provide a flat mounting surface for power head.**

**NOTE:** If anchor pad is covered by drywall, a drywall adapter must be installed between center bracket and the wall with 1/4 x 2" lag screws.

If applying center bracket directly to wood framing, mount center bracket with 1/4 x 1-1/2" lag screws and discard drywall adapter.

Slide operator center bracket onto driven gear from underneath. Next, position center bracket up or down to level torque tube with top of door and secure center bracket to anchor pad with (1) 1/4" lag screw in bottom hole as shown.

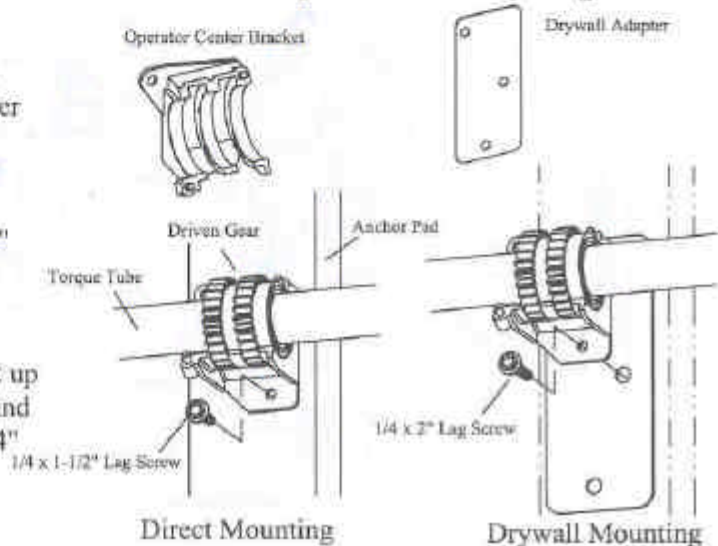

## Center Bracket/Power Head Installation Cont'

Unravel interface cable and pre-install cable into (2) cable clips leaving enough cable to plug into right hand endcap. Route interface cable behind torque tube as shown. Engage power head to center bracket, aligning holes "A" with pins "B" and meshing gears.

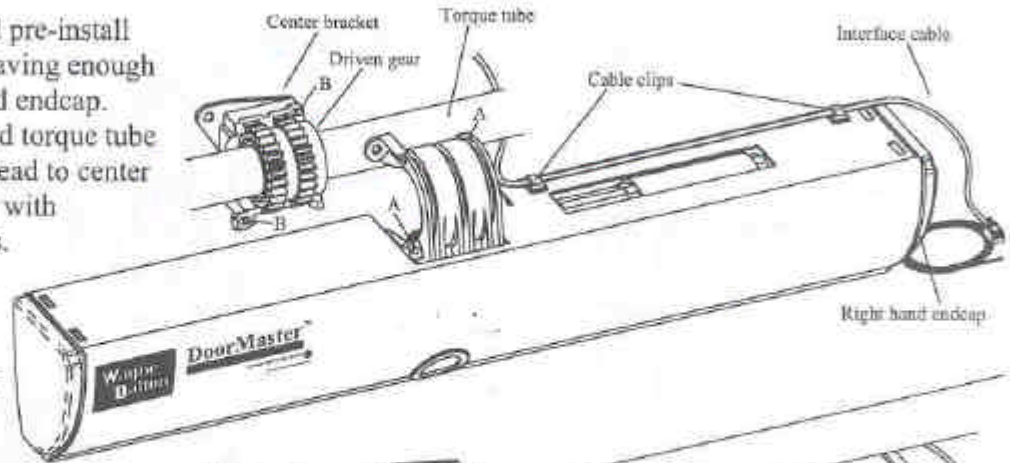

After placing power head onto driven gear and center bracket, slide alignment spacers between torque tube and power head; one on either side of driven gear as illustrated.

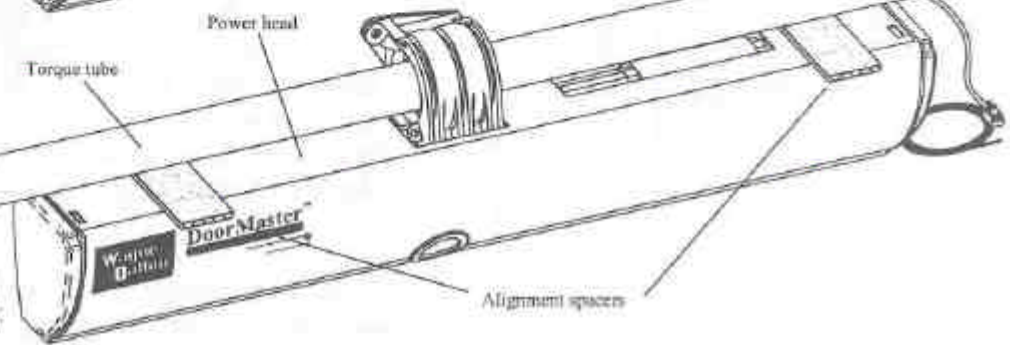

NOTE: Make sure pins "B" are aligned with holes "A". Care should be taken to drive lag screws straight. Drilling 5/32" to 3/16" pilot holes are recommended.

Secure upper lag screw first. Important: To avoid possible damage, this mounting foot must be supported underneath by a solid mounting surface before tightening lag screw. Secure lower lag screw. Remove alignment spacers.

NOTE: All leveling adjustments of power head must be done prior to driving either of these last two lag screws.

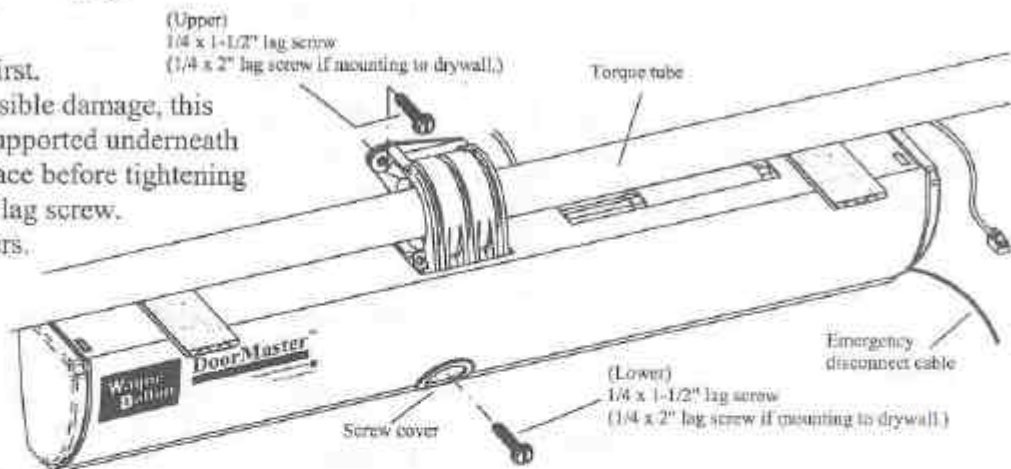

Insure door moves freely.

Unravel emergency disconnect cable.

Once all lag screws are secure, remove emergency disconnect clip by pulling clip to the right and down until clip is removed. Discard clip.

Rotate torque tube slightly by hand, in the door closing direction, until power head and torque tube lock together.

**Important: Do not remove emergency disconnect retention clip until power head gears are engaged and all lag screws secured.**

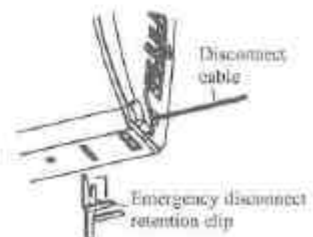

## 3 Emergency Disconnect Installation

**A.**  
Install grommet into right hand flag angle.

**B.**  
Thread disconnect cable through grommet.

**C.**  
Mark location on right door jamb 6 feet above the ground to mount disconnect handle.

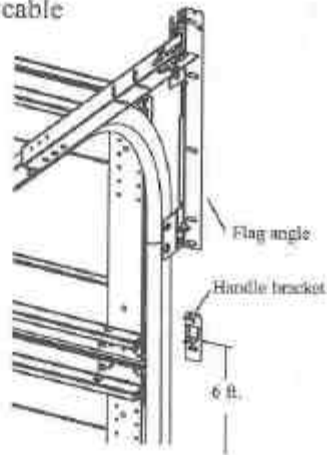

**D.**  
Thread disconnect cable through handle bracket, disconnect handle, and cable sleeve as shown.

**NOTE:** To ease cable installation, bend end of cable with pliers as shown before threading through handle.

Align handle bracket with mark on wall, slide cable sleeve to where cable exits handle.

**E.**  
Route cable back through sleeve, flatten cable loop, slide sleeve over loop until flush, and crimp sleeve with pliers or crimping tool as shown.

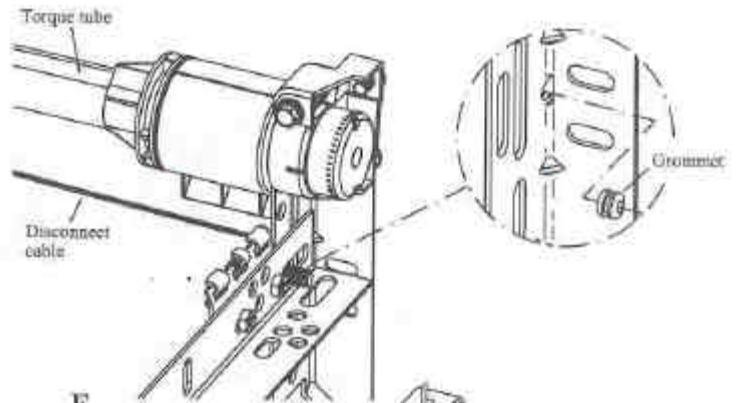
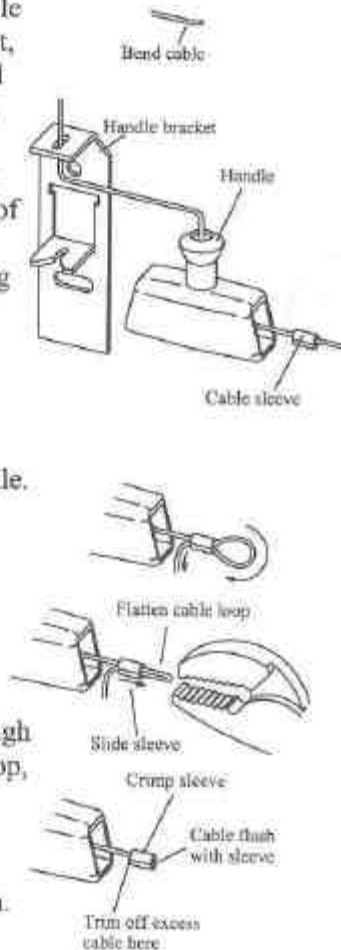

**F.**  
Slide handle over crimped cable sleeve until sleeve is firmly seated in center of handle as shown.

**Important! Firmly seat sleeve in handle before mounting handle bracket.**

**G.**  
Slide handle bracket down just enough to remove cable slack between power head and flag angle.  
**NOTE:** Pulling cable beyond this point will start disengaging power head. Secure handle bracket to jamb with (1) 1/4 x 1-1/2" lag screw in bottom hole.

**H.**  
Pull handle aside until upper hole is exposed in handle bracket and secure handle bracket with another 1/4 x 1-1/2" lag screw in upper hole.

Test disconnect operation.

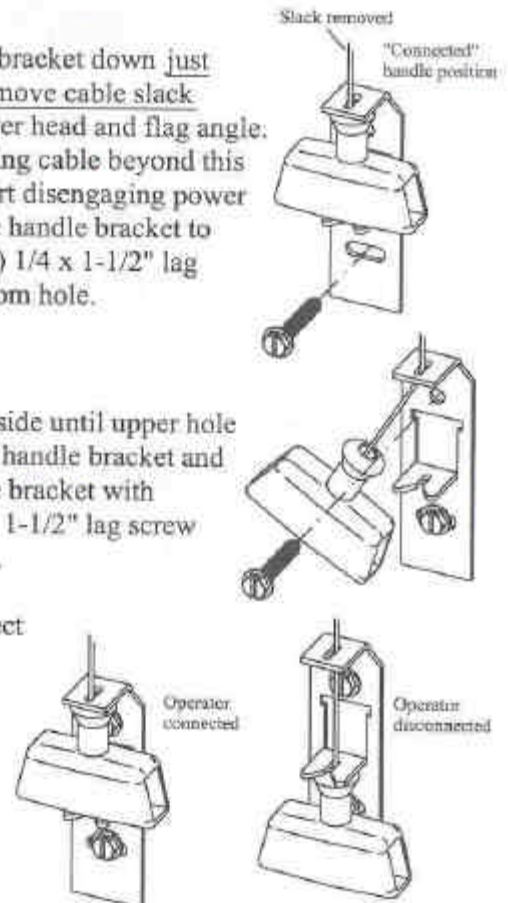

## 4

## Photoelectric Sensor Installation

**NOTE:** Proceed to **Wall Station Installation** if installing Model BDOR-2000 Operator. Continue with **Photo Electric Sensor Installation for Model BIRW-2000**. Photoelectric sensors are not required on the BDOR-2000 model, however, they are available as an optional accessory (P/N 285338).

### STEP 1: Wall Bracket Installation

Select a mounting position 5 inches above floor to center line of wall bracket. Sending and receiving units should be mounted inside door opening to minimize any interference by the sun. However, sensors should be mounted as close to door track or inside edge of door as possible to offer maximum entrapment protection. It is very important that both wall brackets be mounted at the same height for proper alignment.

Using 1/4" x 3/4" lag screws provided, attach wall mounting bracket to wall. In some installations it may be necessary to attach wooden spacers to wall to achieve required clearance. Expansion bolts (not supplied) may be required to attach brackets to walls constructed of materials other than wood or gypsum.

Slide adjusting brackets on top of wall mounting brackets and secure, using 1/4-20 carriage bolts, washer, and nuts supplied. Do not tighten at this time. Make sure alignment allows for sending and receiving units to point toward each other and that they will not be obstructed by door tracks or other objects.

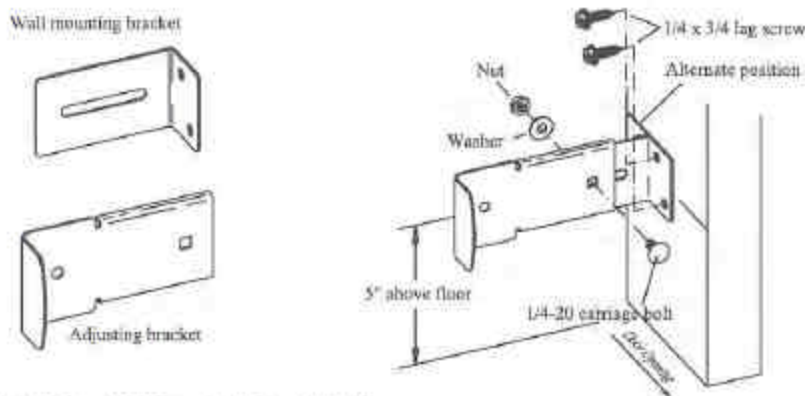

### STEP 2: Quick Install Bracket Installation

Two bracket mounting heights are available for use. Normally the upper mounting slot is used, but if bottom of track is installed more than 1/2" off of floor the bottom slot may need to be used to maintain 6" maximum photo beam height. Slip the slide lock tab into the door track mounting slot. Slide the bracket downward until it seats at the bottom of the slot. Repeat for opposite side. If needed, use a flat blade screwdriver against the top edge of the bracket and gently tap into position with hammer.

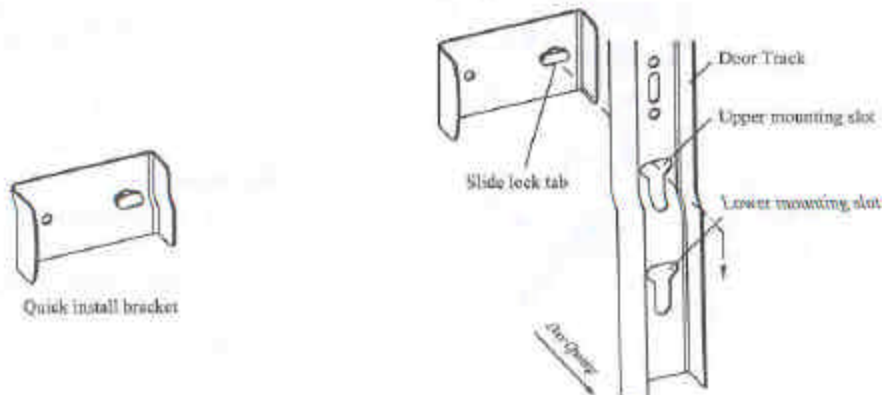

Identify which side of garage door opening (if any) the sun is "likely" to shine on to. Since sunlight may affect photoelectric sensors, sending unit (not the receiving unit) should be mounted on side of door opening exposed to sun.

Place photo eye stem through hole in mounting bracket (quick install or wall mount) with wiring exiting bottom of sensor housing. Screw zip nut onto stem supporting housing with palm of one hand until housing is fully seated against bracket. Repeat for opposite side.

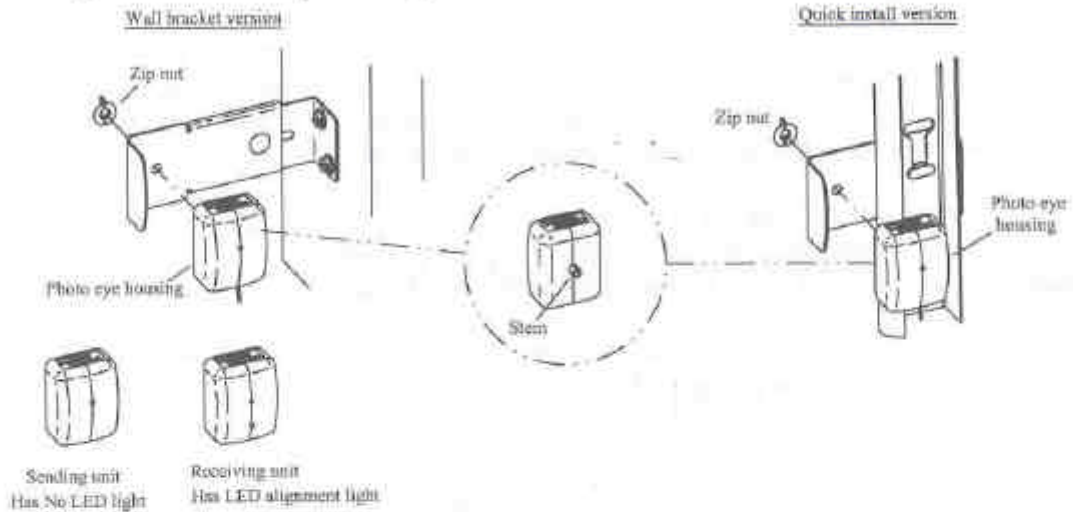

Uncoil wires from photoelectric sensors and route wire up garage wall and along door header towards right side of power head. Route wires behind torque tube and tack wires in place with insulated staples (not supplied).

Connect photoelectric sensors to power head as shown. Solid color wires connect to COM terminal and wire with a black stripe connects to OBS terminal. Shorten wires as necessary and separate wire ends. Strip about 1/2" of insulation off each wire and attach wire to proper terminals, then tighten securely, using a small blade screwdriver.

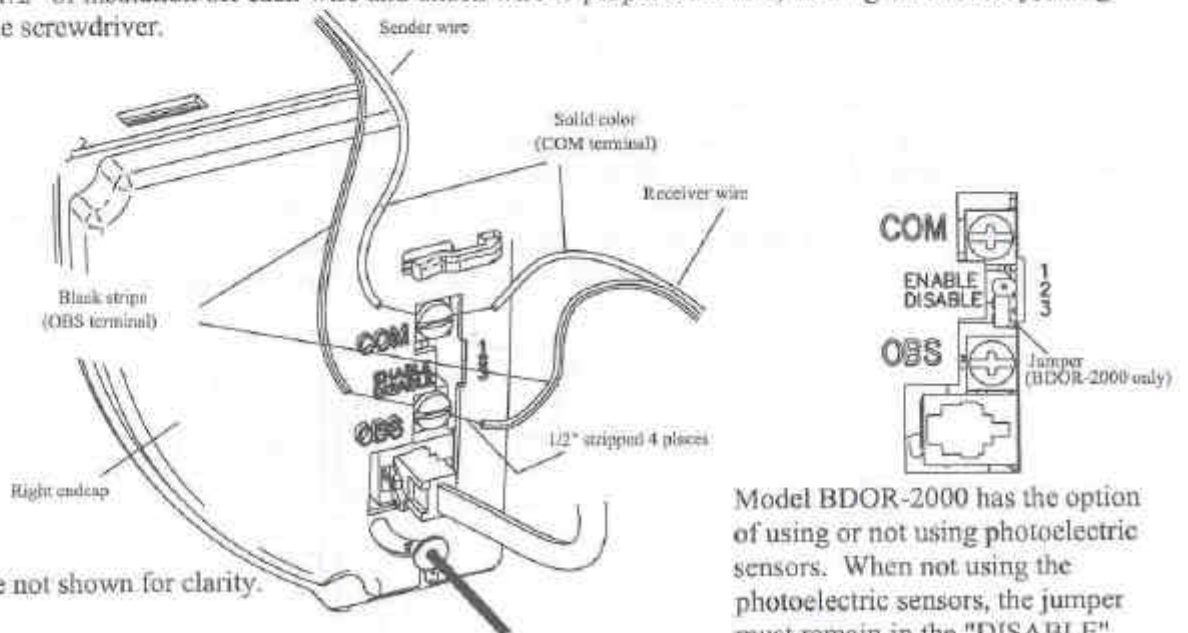

Torque tube not shown for clarity.

Model BDOR-2000 has the option of using or not using photoelectric sensors. When not using the photoelectric sensors, the jumper must remain in the "DISABLE" position (pins 2 & 3).

5

# Wall Station Installation

Locate a convenient place to mount wall station. Measure five feet up from floor and secure wall station base into wood wall framing using (2) #6 x 1-1/4" phillips drywall screws. Use two left side holes for vertical framing or two bottom holes for horizontal framing. Use drywall anchors if not fastening to wood. Caution: Overtightening of screws into wood could deform the plastic base and interfere with circuit board snaps.

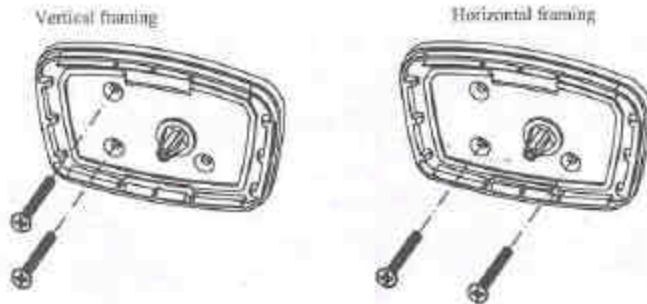

Insert bottom of circuit board behind bottom snap of wall station base. Pivot circuit board up until board snaps into place. For best results, press on circuit board between two battery terminals as shown.

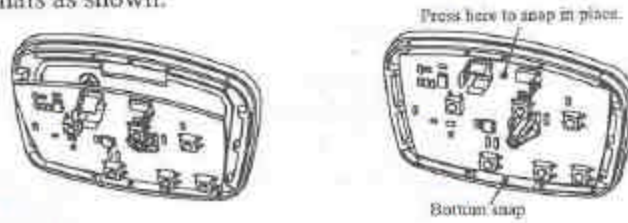

Insert battery into circuit board being careful to match (+) positive battery marking with (+) positive circuit board marking.

Align wall station cover/button assembly with base and circuit board. Press cover over base until cover snaps into place. A uniform seam between cover and base indicates a proper installation.

Apply the wall station operation reference label in a convenient location next to the wall station.

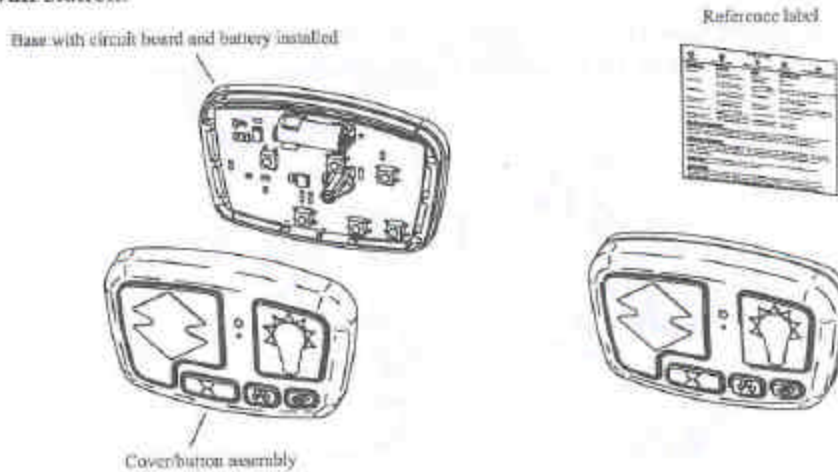

## 6 Light Fixture Installation

Before installing fixture bracket to ceiling, pre-assemble bracket to light fixture snap posts to become familiar with the force required to engage snaps. Remove bracket from light fixture.

Find a location on the ceiling, within four feet from a 120 volt grounded electrical outlet and within reach of the Interface Cable from power head, to mount light fixture. NOTE: Door must clear light fixture when door is in the up position.

Orient and secure fixture bracket to ceiling using (2) #10 x 1-1/2" wood screws as shown. NOTE: Make sure screws are installed into wooden ceiling framing members and not just into drywall. There are two sets of holes in brackets 90° apart to insure screws are secured into a wooden frame member.

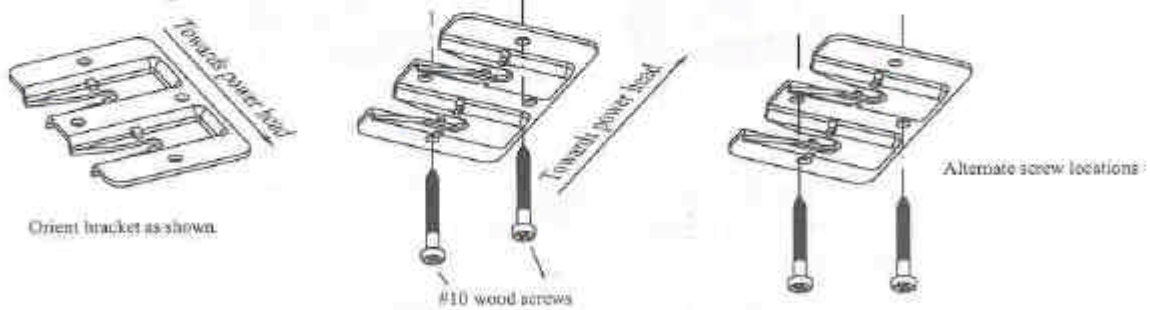

Align two snap posts on light fixture with two corresponding slots in fixture bracket, making sure interface socket is facing towards power head as shown. Slide light fixture into fixture bracket as shown until light fixture snaps into place.

*HINT: As snap posts start to engage resistance, snap one side then the other to reduce force required to snap in place.*

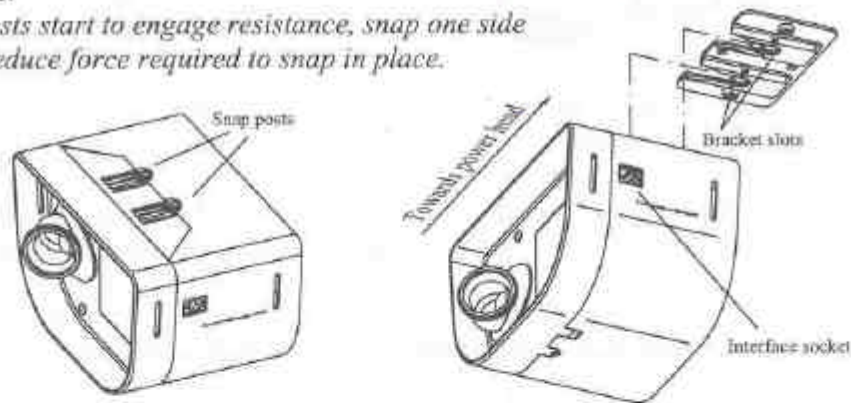

Install a 75 Watt maximum bulb into each socket. For maximum bulb life, "rough service" bulbs are recommended. Snap diffusers into light fixture by squeezing two snaps together as diffusers are inserted into light fixture.

