

TorqueMaster™ & *idrive*™

9900/9600/9200/9100

INSTALLATION INSTRUCTION SUPPLEMENT

When installing an *idrive*™ opener with this door use this supplement to the main door instructions as follows:

- 1) Begin with Step 1 of the main door instructions.
- 2) Replace Step 8 of the main door instructions with Step 8 of the attached supplement.
- 3) Replace Steps 12 through 17* of the main door instructions with the Steps 12 through 17b of the attached supplement.

*Supplement replaces Steps 12 - 18 on single spring doors

TorqueMaster™ & iDrive™

9900 Thermowayne™

9600 Thermogard®

9200/9100 Foamcore™

INSTALLATION INSTRUCTIONS INSERT

Follow the corresponding steps in this insert with the steps in the installation manual provided with the door. These modifications are designed to accommodate the new iDrive™ garage door opener.

8 Top Bracket Installation

To install the L-shaped top brackets, align the top holes in the top bracket with the first set of holes in the endcap for 9900 Thermowayne™ doors and second set of holes for 9600 Thermogard® doors and 9200/9100 Foamcore™ doors. Fasten using (4) 1/4-20 x 5/8" self tapping screws. Secure the top bracket slide to the bracket using (2) 1/4-20 x 5/8" carriage bolts and nuts. Insert rollers. (see **Fig. 1**)

NOTE: To differentiate between a 9900 Thermowayne™, 9600 Thermogard® and 9200/9100 Foamcore™ door models, look for the following characteristics:

1) 9900 Thermowayne™
(below) will have painted hardware (top brackets, bottom brackets, end caps, etc.) with a steel backing on the sections.

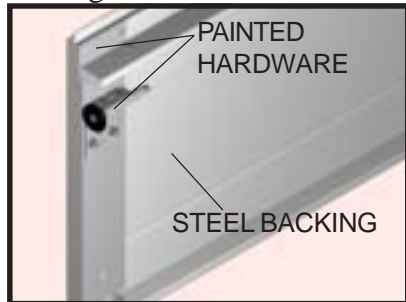

2) 9600 Thermogard® (right) will have galvanized hardware, with a steel backing on the sections.

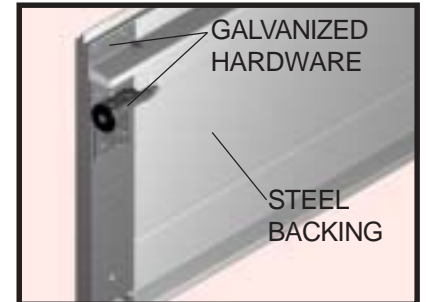

3) 9200/9100 Foamcore™
(below) will have galvanized hardware, with a laminated (soft) backing on the sections.

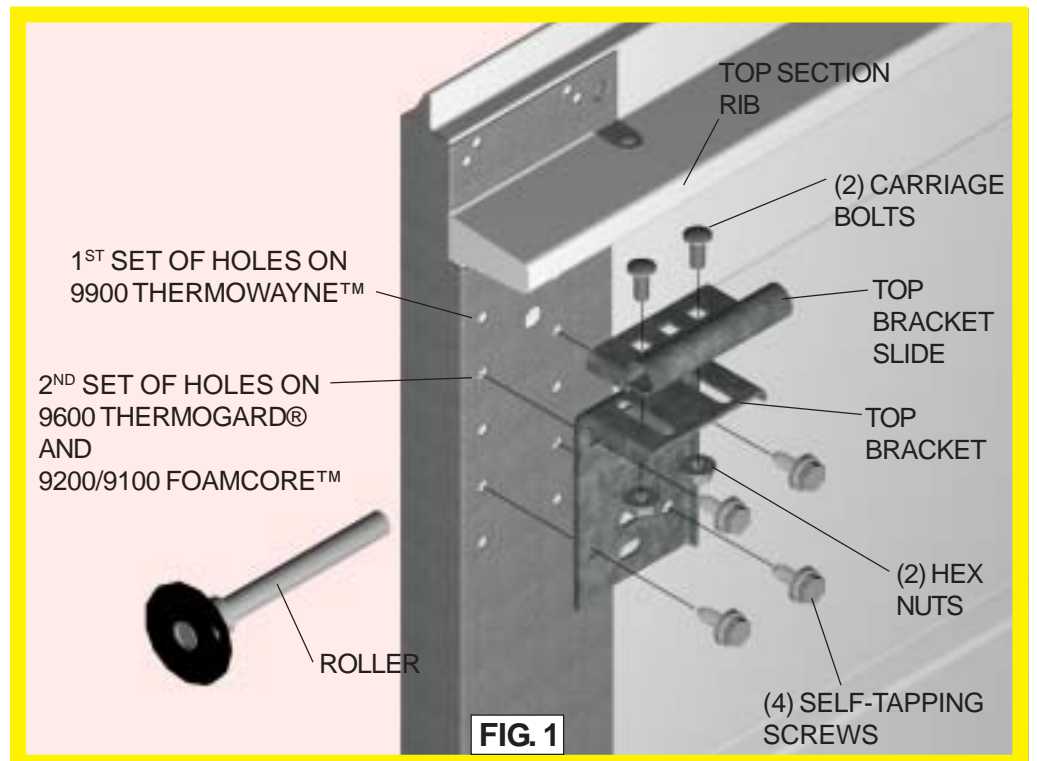
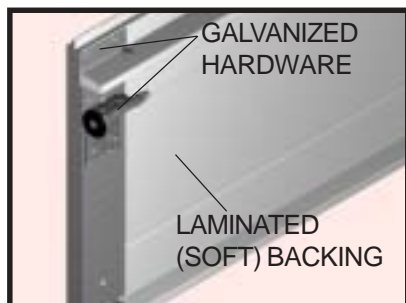

The *idrive*™ garage door opener is best installed in combination with the door installation steps. Refer to this *idrive*™ installation insert when you reach **Step 12 TorqueMaster™** installation, in the main door installation instructions and owners manual. When instructed to slide the center bracket/bushing onto the torque tube, replace that step with the following instructions below, which will provide the steps necessary to install the TorqueMaster™ system, as well as the preliminary installation steps for the *idrive*™ garage door opener.

12 Power Head Assembly

Lay the torque tube on the floor (inside garage) in front of the door with the labeled end to the left. **NOTE: Opener will not slide over a torque tube label.** Attempting to slide opener over the left end of the torque tube can damage the internal electronics.

NOTE: Hold opener by the main body. Do NOT hold by the motor.

Look into the opener's left side to ensure the left hand bearing and the internal (black) sleeve are aligned with the torque tube profile. Once aligned, slide the opener power head onto the right hand end of the torque tube. As the right end of the torque tube enters the internal (black) sleeve, rotate the opener back and forth slightly to help aid alignment. **NOTE: Do not force the opener onto the torque tube if misalignment occurs.**

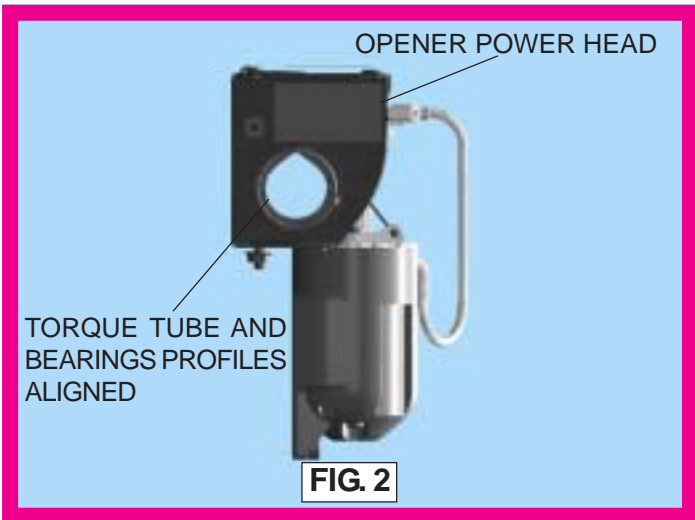
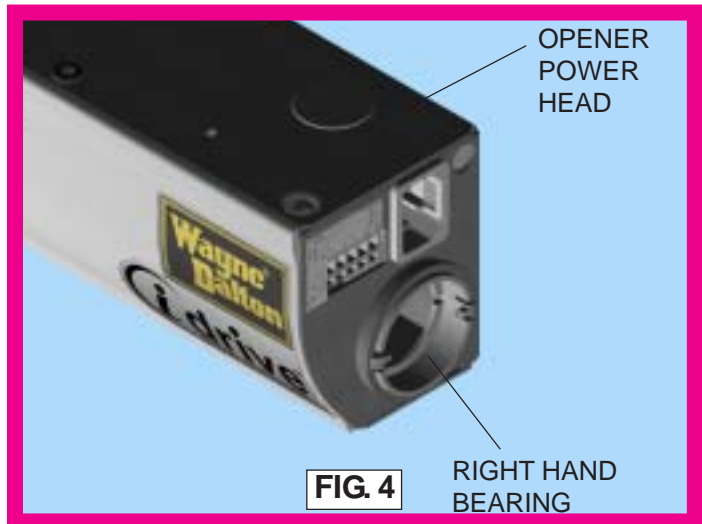
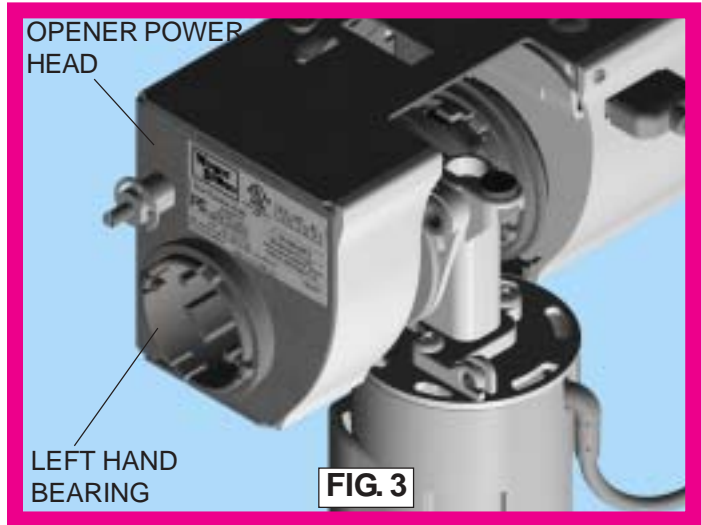

Continue sliding the opener power head onto the torque tube. Align the right hand bearing with the torque tube and slide the opener power head completely onto the torque tube until the torque tube exits the opener power head's right hand bearing. Continue sliding the opener power head to the center of the torque tube and plug the motor into the opener power head.

IMPORTANT! Right and left hand are always determined from inside the garage looking out.

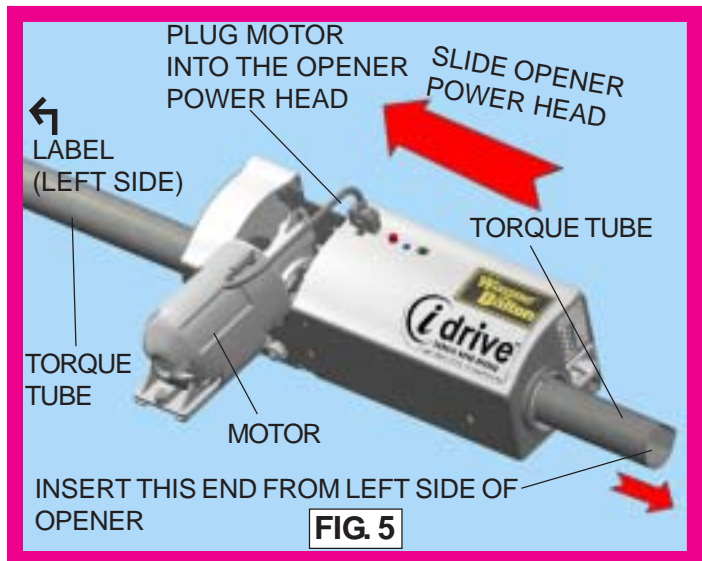



FIG. 21

Locate right hand drum wrap. Slide back half of the drum wrap behind drum placing the right end wall between the drum and flag angle. Close front half of the drum wrap around drum, engage inboard snap and press firmly until a distinct snap is felt. Outboard catch must be engaged as shown. Confirm both snap and catch are fully engaged by lightly tugging against them. Repeat for the left side.

Refer back to the main door manual and continue door installation at the **REAR SUPPORT INSTALLATION Step 18.** (Step 19 in the Single Spring TorqueMaster™ Installation Instructions)

After door installation is completed, refer to the *idrive™* owner's manual, starting at the **PRE-OPERATION INSTALLATION** section to complete the opener installation.

NOTE: Refer to the main door manual for counterbalance adjustments.



13

Drum Installation

Shake the torque tube gently to extend the winding shafts out about 5" on each side. For single spring applications, there will be no left hand winding shaft in the torque tube.

Lift the torque tube and rest on top of flagangles. Orient torque tube so that back of opener is flat against header/spring pad. See **Figure 12**

Cable drums and torque tube are cam shaped to fit together only one way. To install the cable drum, slide the drum over the winding shaft until the drum seats against the torque tube. The winding shaft must extend past the drum far enough to expose the splines and the groove. Align the winding shaft groove with the round notch in the flagangle. Repeat for opposite side.

NOTE: On single spring applications, take care in handling the loose winding shaft (left side) so that it does not slide back into the torque tube.

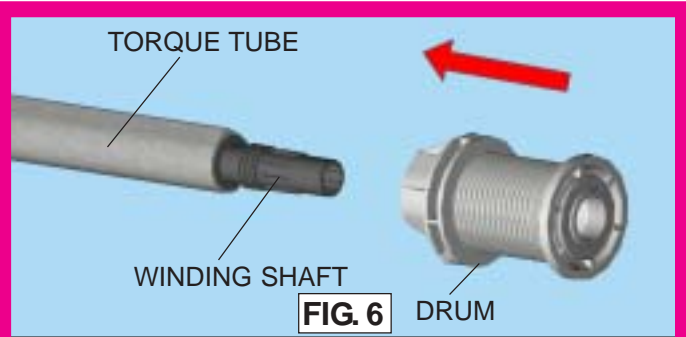

Single Spring Applications: Insert the left hand loose winding shaft into the left hand drum prior to sliding the drum over the torque tube.

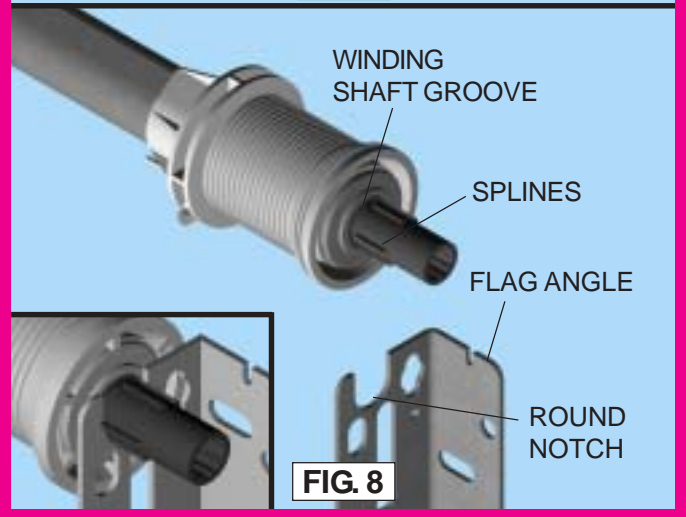
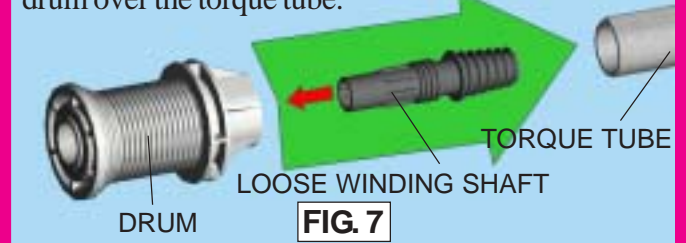

14a

Drive Gear/End Bracket Installation

Ensure that torque tube is centered and level with door.

Beginning with the right hand side, lubricate entire circumference of the drive gear with the oil provided in the packet. Slide the drive gear onto the winding splines until it touches the flagangles.

NOTE: No drive gear is required for the left side on single spring applications.

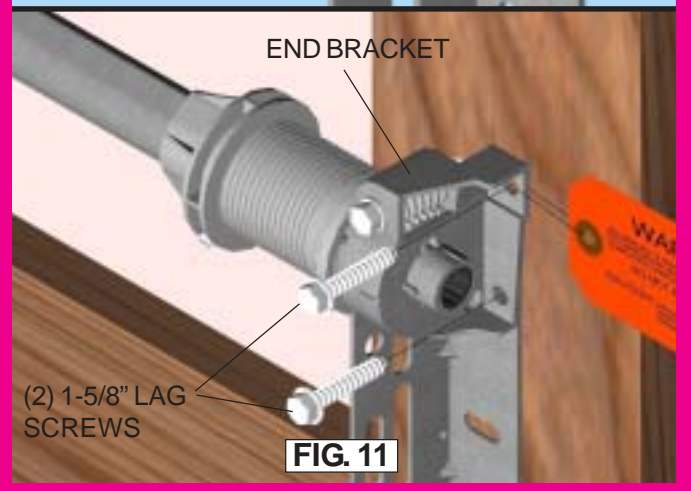
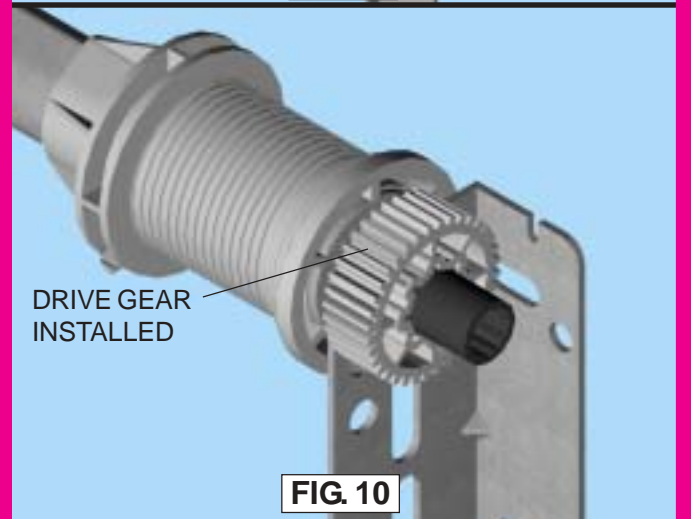
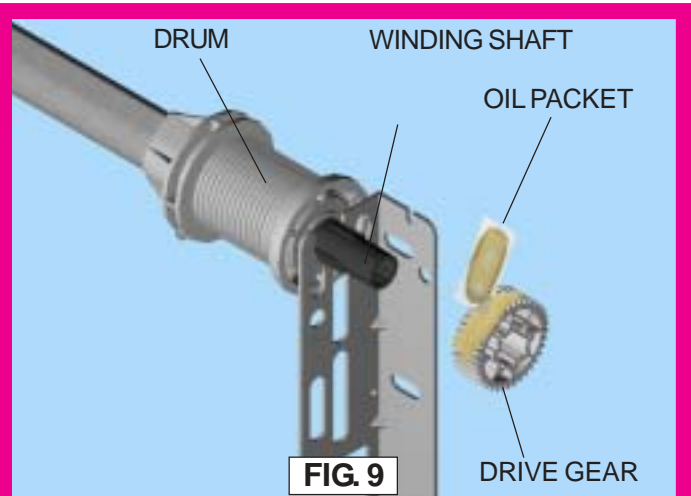

Using the emergency disconnect, pull disconnect handle downwards and place it in the manual door operated position. Use disconnect label for reference. Motor will be rotated 90° from its packaged position.

NOTE: If motor does not pivot 90°, see troubleshooting section in the *idrive™* main installation manual.

16b Cable Adjustments

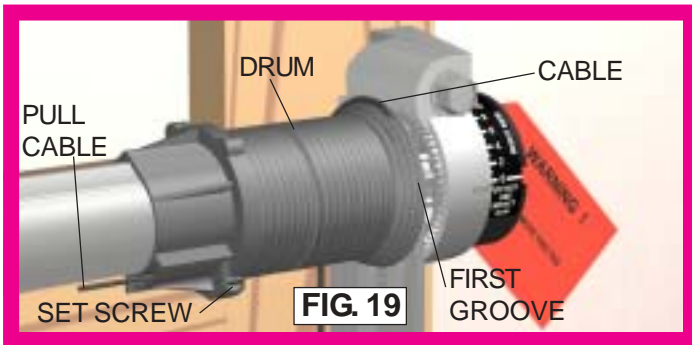

Adjust the counter balance cables by rotating the drum until the set screw faces directly away from the header. Loosen the set screw no more than 1/2 turn. Pull on the end of the cable to remove all cable slack. Check to ensure the cable is aligned and seated in the first groove of the cable drum. Snug the set screw, then tighten an additional 1-1/2 turns. Cut off excess cable.

17a Wind Counterbalance Springs

Clamp locking pliers onto both vertical tracks just above third roller. This is to prevent garage door from rising while winding counterbalance springs.

IMPORTANT! DO NOT USE IMPACT GUN TO WIND SPRING(S)

Beginning with the right hand side. Press and hold in the canoe clip. Ensure the cable is in the first groove of the drum. Using an electric drill (high torque gear reduced to 1300 RPM preferred) with a 7/16" socket, carefully rotate right hand winding bolt clockwise, until counter shows 2-3 turns. This will keep the counterbalance cable taut while adjusting the left hand side counterbalance cable. Repeat for left side on double spring TorqueMaster™ systems. Single spring applications will require no spring pre-winding.

Ensure counterbalance cable tension is equal for both sides prior to fully winding spring(s) to appropriate number of turns.

Carefully rotate the winding bolt head clockwise until the counter show the correct number of turns for your door. See the chart below. Repeat for the opposite side on double spring TorqueMaster™ systems.

If door raises off of floor remove 1/2 - 1 full turn from each spring before proceeding.

After spring is wound, hold the lock nut stationary with a 7/16" wrench while rotating the winding bolt clockwise until snug. Tightening of the lock nut prevents spring from unwinding. Repeat for opposite side if necessary.

Door Height = Spring Turns	
6'0" Door Height	= 14-1/2 turns (Double Spring) and 15 turns (Single Spring)
6'-3" Door Height	= 15 turns
6'-5" Door Height	= 15-1/2 turns
6'-6" Door Height	= 15-1/2 turns
6'-8" Door Height	= 16 turns
6'-9" Door Height	= 16 turns
7'-0" Door Height	= 16-1/2 turns
7'-3" Door Height	= 17 turns
7'-6" Door Height	= 17-1/2 turns
7'-9" Door Height	= 18 turns
8'-0" Door Height	= 18-1/2 turns

IMPORTANT! Adjustments to the recommended number of turns may be required. **AFTER REAR SUPPORT ASSEMBLY IS COMPLETE** (located in main door manual instructions), check door balance. If door raises off of floor under spring tension alone, then reduce turns until door will rest on floor. A "hot" door such as this can cause *idrive™* operation problems.

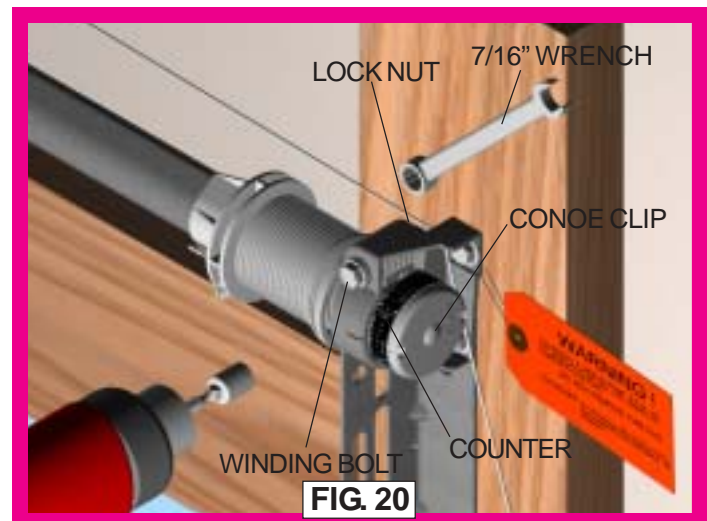

Slide the right hand end bracket over the drive gear. Attach end bracket and the flagangle to the jamb with (2) 5/16 x 1-5/8" lag screws. (see Fig. 11)

14b

Counter Installation

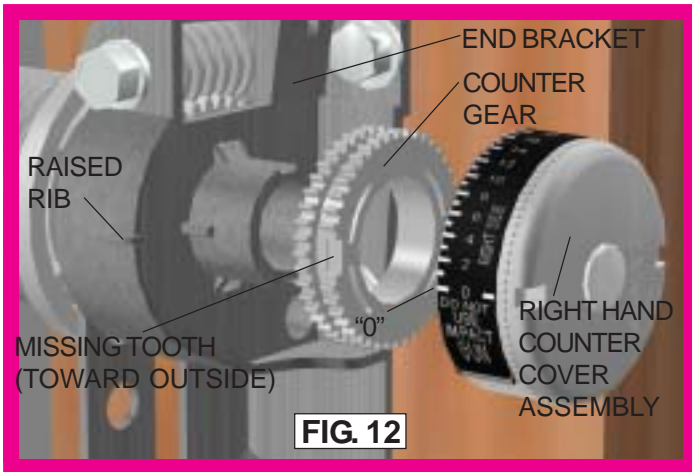

Beginning with the right side, install the counter gear with the missing tooth toward the outside, away from the end bracket. Press the counter gear onto the end bracket until snaps engage. Select the right hand counter cover assembly and align the hex of the counter cam with the end of the winding shaft. Also, align the "0" on the counter cover with the raised rib on the end bracket. Press the counter cover assembly against the counter gear until it locks into place.

Repeat the **Drive Gear/End Bracket Installation and Counter Installation** sections for the left hand side installation.

NOTE: No drive gear, counter gear or counter cover assembly is required on left hand side for single spring applications. Only an end bracket is needed.

IMPORTANT! At this time do not wind counter balance springs!

15

Power Head/ Support Bracket Installation

Locate the spring pad. The spring pad is a vertical running board directly above the door. Remove (2) 1/4-20 flange nuts from bottom of opener power head. **NOTE: Do not discard flange nuts.** Place the support bracket underneath opener power head, to the right side of motor, centered on spring pad.

Level the torque tube to the top of the door section with the *i*drive™ resting on the support bracket. Once torque tube is level, secure support bracket to the spring pad with (2) 1/4 x 2" lag screws.

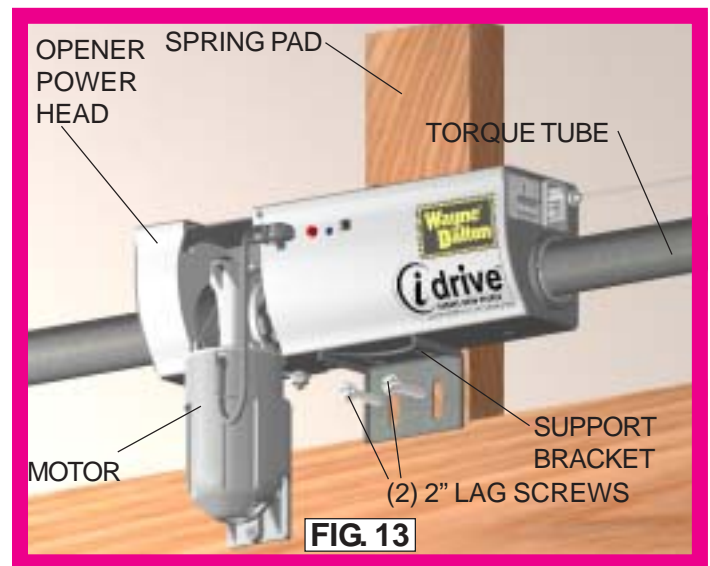

Lift and slide the opener power head over the support bracket, aligning the mounting studs with the bracket slots. Loosely fasten to mounting studs with the (2) 1/4-20 flange nuts. **NOTE: Do not tighten 1/4-20 flange nuts to power head studs at this time.**

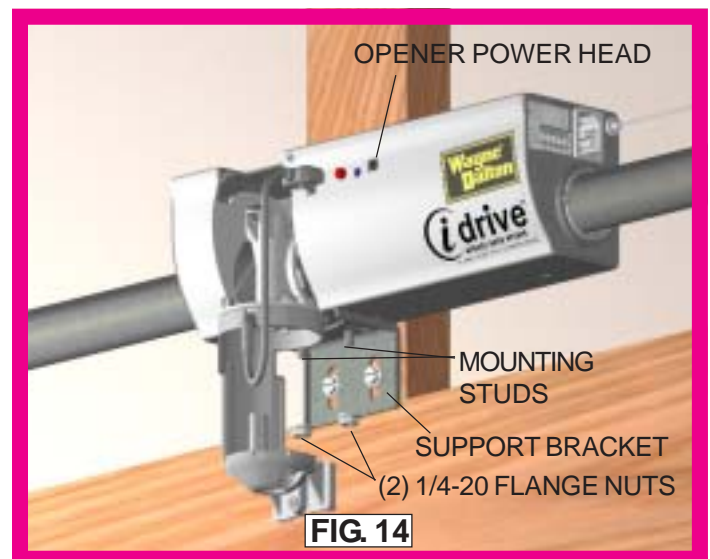

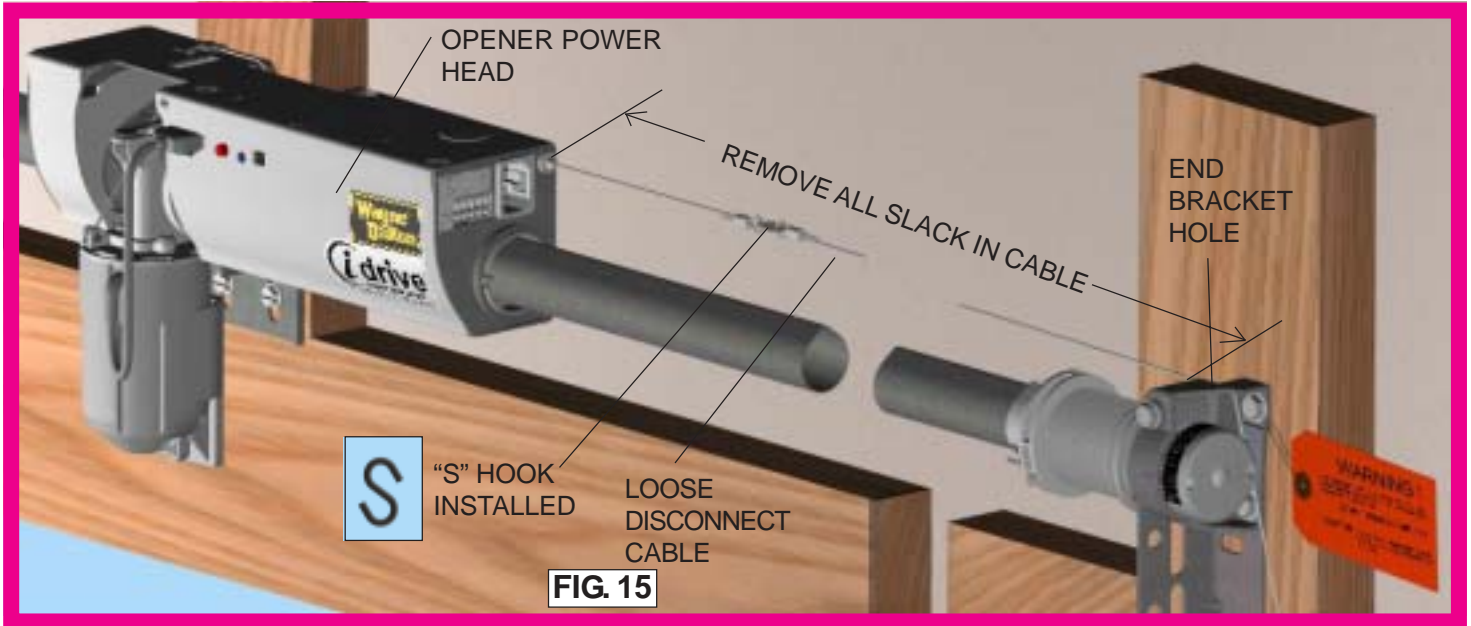

FIG. 15

Attach the loose disconnect cable (located in operator hardware bag) to the opener power head with "S" hook. Close both ends of "S" hook to lock assembly together. Thread the disconnect cable through hole in right hand end bracket and remove all slack between power head and right hand end bracket.

Mark location on right door jamb, six feet above the ground to mount disconnect handle. Thread disconnect cable through handle bracket and then handle. Align top of handle bracket with mark on wall. Remove all cable slack between the power head and top of handle bracket.

Insert and tighten #6-20 x 1/2" screw until snug, and then tighten screw 1 to 1-1/2 additional turns to secure cable in handle. Trim off excess cable from bottom of handle.

Holding handle bracket, remove all remaining slack between

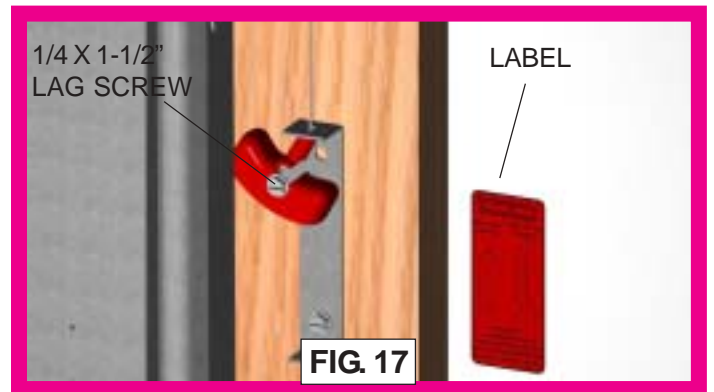

FIG. 17

power head. With slack removed, secure bottom of handle bracket with (1) 1/4 x 1-1/2" lag screw.

CAUTION: Pull handle just enough to remove the cable slack. Pulling the cable more could cause the opener power head to disconnect from the torque tube. Rotate disconnect handle to one side exposing upper mounting hole in handle bracket. Secure handle bracket with a second 1/4 x 1-1/2" lag screw. Apply emergency disconnect label next to the mounted bracket. Use mechanical fasteners if adhesive will not adhere.

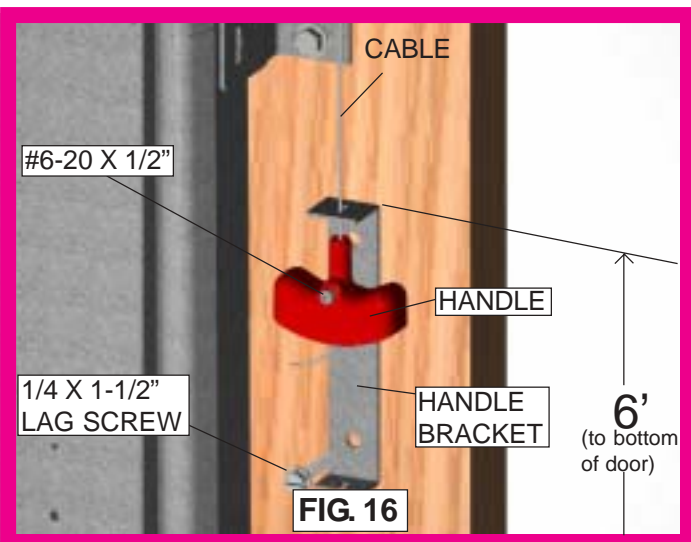

FIG. 16

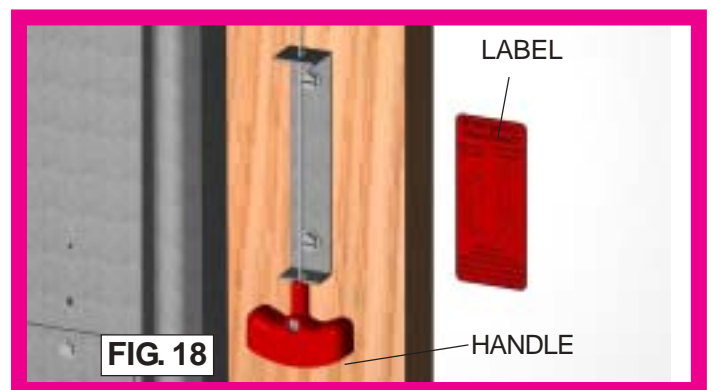

FIG. 18