

# POWERGYM

## 15601 SINGLE STATION HOME GYM

MODEL NO. 15601  
SKU NO. 354.15601  
SERIAL NO.

Write serial number in the space  
above for reference.

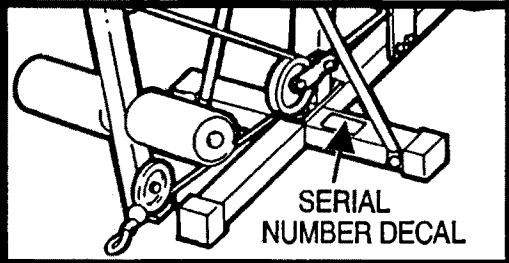

### WAIT, READ THIS FIRST!

If you find this unit to have missing or defective parts  
please have ready the following information listed  
below before calling the 800 NUMBER.

The ASSEMBLY MANUAL  
MODEL NUMBER of this UNIT  
PART NAME or DESCRIPTION  
ORDERING NUMBER  
THE QUANTITY of each part that you need.

THE MODEL NUMBER of this unit can be found  
in the UPPER LEFT-HAND or RIGHT-HAND CORNER  
of this page. The MODEL NUMBER is a series of FOUR  
or FIVE NUMBERS, or a NUMBER preceded by TWO  
LETTERS.

THE PART NAME or DESCRIPTION and the  
ORDERING NUMBER can be found on the PARTS  
LIST PAGE.

# weider

## OWNER'S MANUAL

MADE IN CANADA

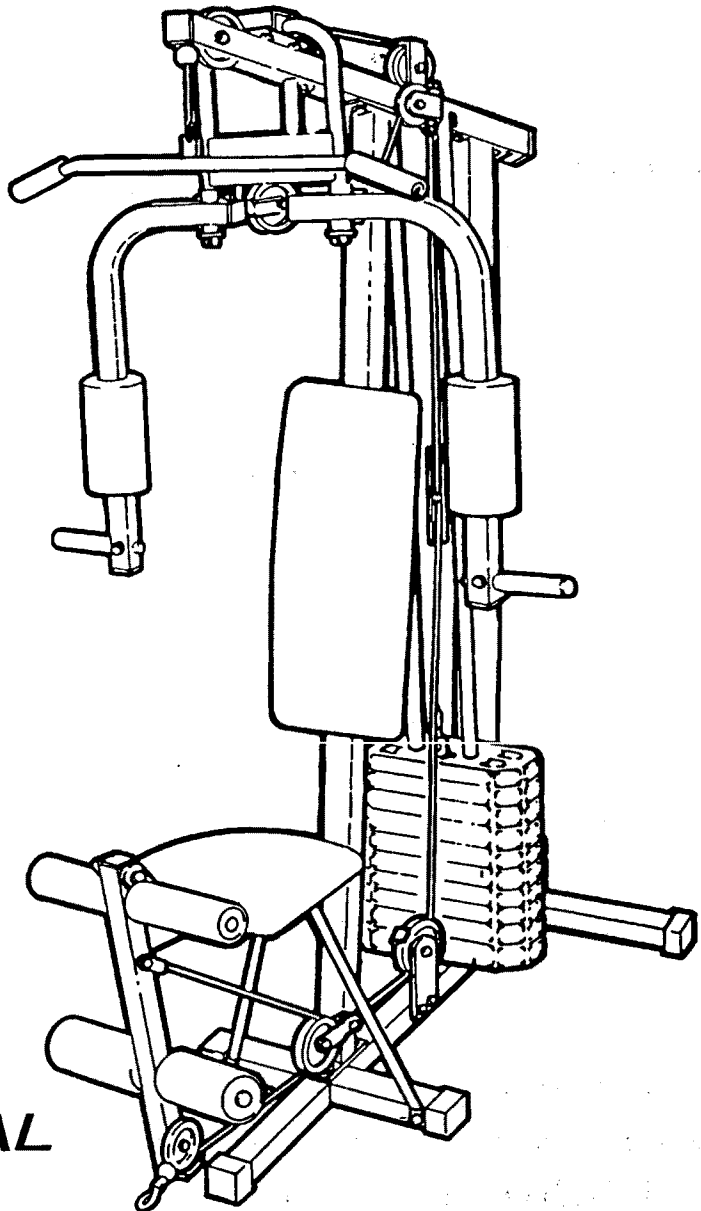

WEIDER is committed to providing you complete customer satisfaction. If you have any questions concerning the assembly of this product or find damaged or missing parts, we guarantee you direct assistance. AVOID THE HASSLE OF CONTACTING THE STORE FOR PARTS OR RETURNING THE PRODUCT. Call our "CUSTOMER ASSISTANCE LINE" for assistance with parts and information by calling our toll free number 1-800-225-0653, Mon. - Fri., 8 am - 5 pm CST.

IMPORTANT: Read all safety precautions and instructions in this manual carefully before using this equipment. Save this manual for future reference.

NN1258156010

WEIDER SPORTS INC.  
21100 Erwin Street, Woodland Hills, CA. 91367 USA

P # 115355  
Om

## TABLE OF CONTENTS

Table of Contents .....	1
Important Safety Precautions .....	1
Introduction .....	2
Assembly Steps .....	6-22
Maintenance Tips.....	2
Conditioning Guide .....	23
Parts List .....	3-4
Ordering Parts .....	5

---

## IMPORTANT SAFETY PRECAUTIONS

**WARNING:** To reduce the risk of serious injury, read the important safety precautions before using this equipment.

1. Read all instructions in this manual before using this equipment.
2. Use this equipment only as described in this Owner's Guide.
3. Inspect and tighten all parts each time this equipment is used. Replace any worn parts immediately.
4. Keep hands away from moving parts other than the designated handles.
5. Keep small children away from this equipment during use.

**WARNING:** Before beginning this or any exercise program consult your physician. This is especially important for individuals over the age of 35 or persons with pre-existing health problems. Read all instructions before using. Weider assumes no responsibility for personal injury or property damage sustained by or through the use of this product.

**SAVE THESE INSTRUCTIONS**

## INTRODUCTION

Thank you for choosing the Weider POWER GYM. Your Home Gym is designed and engineered to give you many hours of aerobic conditioning.

This manual is provided to help you understand the simple assembly, adjustments, and use of the Home Gym. In addition to assembly instructions it also contains, maintenance tips, and parts information.

Please take the time to read all the information contained in this manual and after assembly is completed keep it for future reference.

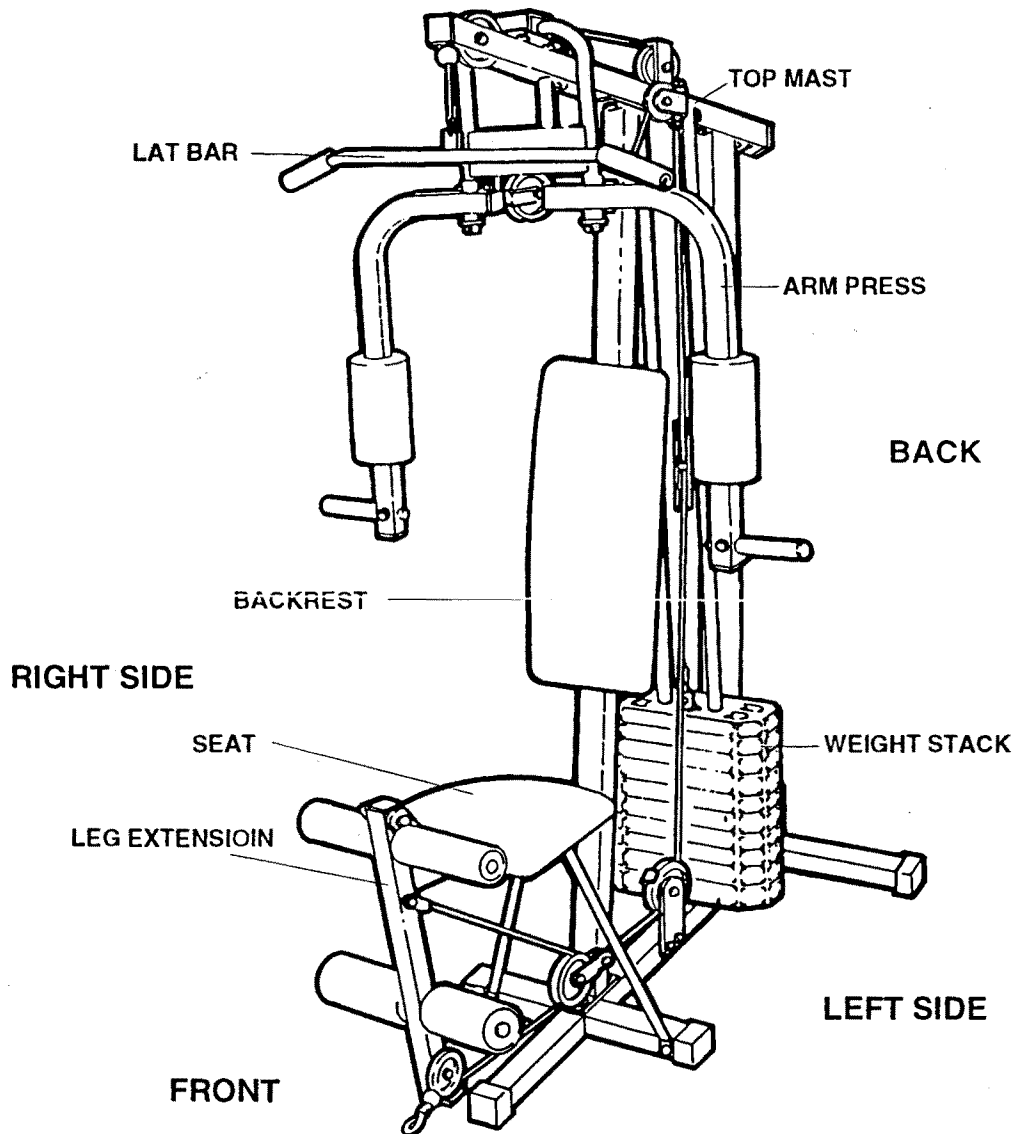

## MAINTENANCE TIPS

Keeping your POWER GYM in good condition will help insure you many hours of safe, enjoyable exercise. Following an easy maintenance routine will prevent premature wear and unnecessary parts replacement.

1. Check all fasteners, nuts and bolts, and caps to see that they are tight and fitted properly.
2. Lubricate all moving parts frequently to keep handles and other parts moving smoothly and eliminate squeaks and excessive noise.
3. Painted surfaces can be cleaned with a soft cloth and mild, non-abrasive detergent.

# 15601 PART LIST

DIAGRAM NO	PART NAME	QTY	ORDERING NO
1	BASE "T"	1	C3211-F29*G04
2	REAR BASE	1	C3212-F29*G04
3	REAR FRAME UPRIGHT	1	C4109-F50*G04
4	ARM PRESS FRAME UPRIGHT	1	C3214-F29*G04
5	SEAT FRAME	1	C3215-F29*G04
6	PULLEY PLATE	1	C6775-F29*G04
7	STEPPER BRACE	1	C6776-F29*G04
8	TOP FRAME	1	C3216-F29*G04
9	ARM PRESS BRACKET	1	C6777-F29*G04
10	SEAT BRACE	1	C6778-F29*G04
11	SEAT MOUNTING PLATE	1	C6779-F29*G04
12	WEIGHT PLATE 12.5 LB.	10	BB-0325*G04
13	WEIGHT SELECTOR TUBE	1	C6384-F29*G04
14	GUIDE ROD	2	C6827-F29*G04
15	SEAT	1	C1379-F29*G04
16	BACKREST	1	C1380-F29*G04
17	LEG EXTENSION TUBE	1	C3217-F29*G04
18	PAD BAR 3/4" X 12 1/2"	1	C6371-F20*G04
19	PAD BAR 3/4" X 13 1/2"	1	C6357-F03*G04
20	FOAM ROLLER 3" X 5 3/4"	2	C0454-E04*G04
21	FOAM ROLLER 2 1/4" X 6"	2	C0449-E08*G04
22	ARM PRESS ASSEMBLY	1	C3218-F29*G04
23	ARM PRESS BUSHING	2	AA-8208*G04
24	ARM PRESS CAP	1	C6783-F29*G04
25	PEC-DECK ARM	2	C3219-F29*G04
26	U-BRACKET - 3 1/2" LONG	2	C7725-F68*G04
27	ARM PRESS HANDLES	2	C6385-F29*G04
28	PULLEY BRACKET	2	C6781-F29*G04
29	PULLEY TRAP BRACKET	1	C6782-F29*G04
30	FOAM ROLLER 3 1/4" X 7"	2	C0467-F23*G04
31	PLASTIC WEIGHT GUIDE BRACKET	1	AA-8241*G04
32	U-BRACKET - 3" LONG	1	C7727-F67*G04
37	PEC-DECK CABLE 127" LONG	1	C6637-F29*G04
38	WEIGHT STACK CABLE 79" LONG	1	C6638-F29*G04
39	LEG EXTENSION CABLE 49" LONG	1	C6639-F29*G04
40	LAT BAR	1	C6831-F32*G04
41	PLASTIC GRIP - 1" I.D. X 5" LONG	4	AA-8255*G04
42	CABLE TRAP BRACKET	4	C6725-E28*G04
43	BENT PULLEY BRACKET	2	C6726-E28*G04
50	4 1/2" PULLEY	4	AA-8122*G04
51	3 1/2" PULLEY	6	AA-8133*G04
52	PULLEY CONNECTOR PLATE	2	C6700-D23*G04
60	5/16" X 2 1/4" HEX HEAD BOLT	6	HH-5199*G04
61	5/16" X 2 1/2" HEX HEAD BOLT	3	HH-5053*G04
62	5/16" X 2 3/4" HEX HEAD BOLT	8	HH-5858*G04
63	5/16" X 3" HEX HEAD BOLT	3	HH-5167*G04
64	5/16" X 1" HEX HEAD BOLT	2	HH-5332*G04
65	5/16" X 1 1/2" HEX HEAD BOLT	3	HH-5312*G04

# 15601 PART LIST

DIAGRAM NO	PART NAME	QTY	ORDERING NO
66	5/16" x 2" HEX HEAD BOLT	5	HH-5054*G04
67	5/16" x 3 1/4" HEX HEAD BOLT	1	HH-5297*G04
68	5/16" X 3/4" HEX HEAD BOLT	1	HH-5245*G04
70	5/16" FLAT WASHER	22	HH-5127*G04
71	5/16" NYLON LOCK NUT	35	HH-5012*G04
72	3/8" X 2 1/2" HEX HEAD BOLT	1	HH-5018*G04
73	3/8" X 1 3/4" HEX HEAD BOLT	9	HH-5308*G04
74	3/8" X 2 3/4" HEX HEAD BOLT	1	HH-5036*G04
78	3/8" FLAT WASHER	4	HH-5265*G04
79	3/8" NYLON LOCK NUT	11	HH-5088*G04
80	1/4" X 2 1/2" CARRIAGE BOLT	2	HH-5333*G04
81	1/4" X 3/4" MACHINE SCREW	8	HH-5022*G04
82	1/4" X 2 1/2" MACHINE SCREW	2	HH-5044*G04
83	1/4" X 1 1/2" HEX HEAD BOLT	2	HH-5027*G04
84	1/4" X 1 3/4" HEX HEAD BOLT	1	HH-5024*G04
85	1/4" X 2" CARRIAGE BOLT	1	HH-5338*G04
86	1/4" FLAT WASHER	3	HH-5048*G04
87	1/4" NYLON LOCK NUT	9	HH-5011*G04
88	#8 SHEET METAL SCREW	2	HH-5449*G04
89	LATCH HOOK	1	WW-7042*G04
90	1 1/8" X 2 1/2" PLASTIC BUSHING	2	AA-8210*G04
91	1/2" X 1/2" ZINC BUSHING	1	HH-5459*G04
92	SPACER 1/2"	2	HH-5346*G04
93	1 1/2" SQUARE PLASTIC INSERT CAP	5	AA-8001*G04
95	2" SQUARE PLASTIC COVER CAP	5	AA-8015*G04
96	2" SQUARE PLASTIC INSERT CAP	2	AA-8002*G04
97	1 1/4" SQUARE PLASTIC INSERT CAP	2	AA-8069*G04
98	3/4" ROUND PLASTIC INSERT CAP	4	AA-8004*G04
99	1" ROUND PLASTIC INSERT CAP	6	AA-8005*G04
105	1" O.D. X 1" LONG BUSHING	1	AA-8211*G04
106	3/8" LONG METAL SPACER	2	HH-5428*G04
110	WEIGHT SELECTOR END TUBE CAP	1	AA-8123*G04
112	1 3/16" X 2" LARGE WASHER	2	HH-5460*G04
114	LARGE RUBBER WASHER	2	AA-8124*G04
115	PEC-DECK LOCKING PINS	2	WW-7013*G04
120	WEIGHT PLATE DECALS	1 SET	DE-4249*G04
121	STATION 1 DECAL	1	DE-4249*G04
122	POWER STACK DECAL	1	DE-4249*G04
123	ULTRA FORCE XT DECAL	2	DE-4249*G04
	ASSEMBLY MANUAL	1	CNN-1258*G04
	TRAINING MANUAL	1	CNN-1217*G04
	HARDWARE BAGS		
	STEPS 1 - 5	1	C8794-G04*G04
	STEPS 6 - 9	1	C8795-G04*G04
	STEPS 10 - 14	1	C8796-G04*G04
	STEPS 15 - 17	1	C8797-G04*G04
	PULLEYS	1	C8798-G04*G04

## ORDERING PARTS

Weider is dedicated to insure that each product is manufactured to the highest standards and that this product reaches the customer in the best possible condition. In the event that you find any problem in workmanship or missing parts please call our toll free product service number: 1-800-225-0653.

Weider provides replacement parts at no charge to the customer for one year if it is determined that the part was defective from the manufacturer or if any part is missing from the original, un-opened carton.

If it becomes necessary to order replacement parts the following action and information is required:

**1. Your Owner's I.D. card must be returned to us to verify the product you have purchased, your name, address, and the date of your purchase. No charge replacement parts will not be sent without this information on file with our Parts Department.**

**2. Parts may be ordered using the parts order card which is included with this product or by calling our product service number: 1-800-225-0653.**

**3. Before ordering parts by phone have ready the following information to expedite your order:**

- a. Name of the product (POWER GYM)
- b. Model number of product (15601)
- c. Serial number of the product located on a decal on the frame  
(See drawing on front cover for the location of this decal.)
- d. Ordering number of part (See Parts List page.)
- e. Description of the part from the Parts List page
- f. Country of manufacturer (See cover.)

The same information is required when placing your order by mail.

If you need parts or assistance do not return this product to the store, simply contact Weider Customer Assistance at 1-800-225-0653 Monday - Friday 8 a.m. - 5 p.m. CST.

All parts and service inquiries should be directed to:

Weider Sporting Goods  
Parts Service Department  
900 West St. John Street  
Olney, Illinois 62450

## STEP 1 BASE FRAME ASSEMBLY

PART NAME	QTY
60 5/16" X 2 1/4" HEX HEAD BOLT	4
62 5/16" X 2 3/4" HEX HEAD BOLT	2
70 5/16" FLAT WASHER	2
71 5/16" NYLON LOCK NUT	6
95 2" SQUARE PLASTIC COVER CAP	3

**CAUTION: DO NOT TIGHTEN THE BOLTS IN THE ASSEMBLIES OF STEPS 1,2,3, AND 4 UNLESS YOU ARE INSTRUCTED TO DO SO IN THAT ASSEMBLY BOX. YOU WILL BE INSTRUCTED TO TIGHTEN THE BOLTS AFTER STEP 4 ASSEMBLIES ARE COMPLETED.**

- Begin by capping each tubing end of the REAR BASE (2) with 2" SQUARE PLASTIC COVER CAPS (95).
- Cap the end of the BASE "T" (1) with a 2" SQUARE PLASTIC COVER CAP (95).
- Orient the Base "T" and the Rear Base so that the dimpled-in holes are faced to the floor.
- Assemble the BASE "T" (1) to the REAR BASE (2) by bolting with 5/16" X 2 1/4" HEX HEAD BOLTS (60) up through the bottom of the Rear Base, then through the Base "T". Secure with 5/16" NYLON LOCK NUTS (71).
- To the BASE "T" (1), assemble the REAR FRAME UPRIGHT (3) so that the one slanted bracket welded to the one end of the Upright is to the top and slants downward from the front of the unit to the rear. Attach with 5/16" X 2 1/4" HEX HEAD BOLTS (60) by bolting up through the bottom of the BASE "T" (1) and then through the welded brackets on the Upright. Secure with 5/16" NYLON LOCK NUTS (71).
- Assemble the PULLEY PLATE (6) to the side of the BASE "T" (1) using 5/16" X 2 3/4" HEX HEAD BOLTS (62) to bolt through the Plate and then through the Base "T". Assemble 5/16" FLAT WASHERS (70) onto the Bolts and secure with 5/16" NYLON LOCK NUTS (71).

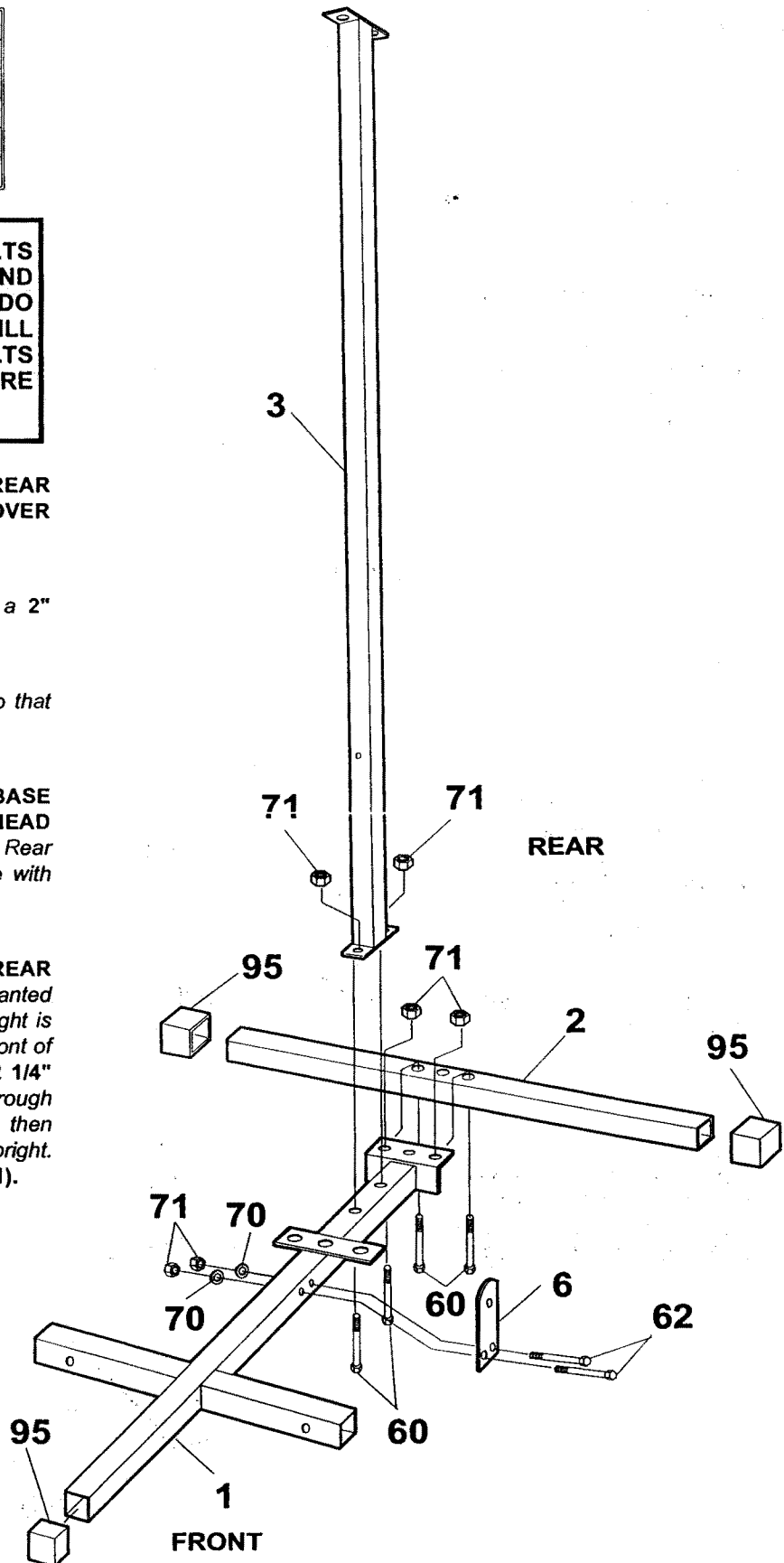

## STEP 2 ARM PRESS & SEAT FRAME ASSEMBLY

PART NAME	QTY
60 5/16" X 2 1/4" HEX HEAD BOLT	2
61 5/16" X 2 1/2" HEX HEAD BOLT	2
70 5/16" FLAT WASHER	2
71 5/16" NYLON LOCK NUT	4
93 1 1/2" SQUARE PLASTIC INSERT CAP	1
97 1 1/4" SQUARE PLASTIC INSERT CAP	1

To the front of the BASE "T" (1) at the Cross-member tube, assemble the ARM PRESS FRAME UPRIGHT (4). Using 5/16" X 2 1/4" HEX HEAD BOLTS (60) bolt up through the bottom of the Base "T" and then through the welded brackets of the Upright. Secure with 5/16" NYLON LOCK NUTS (71).

With the welded leg curl brackets of the SEAT FRAME (5) oriented up, attach the Seat Frame to the ARM PRESS FRAME UPRIGHT (4) with 5/16" X 2 1/2" HEX HEAD BOLTS (61). Bolt through the Seat Frame brackets, and then through the Arm Press Frame Upright. Assemble 5/16" FLAT WASHERS (70) onto the bolts and secure with 5/16" NYLON LOCK NUTS (71).

Cap the end of the SEAT FRAME (5) with a 1 1/2" SQUARE PLASTIC INSERT CAP (93).

Cap the Welded Stopper Tube at the top of the ARM PRESS FRAME UPRIGHT (4) with a 1 1/4" SQUARE PLASTIC INSERT CAP (97).

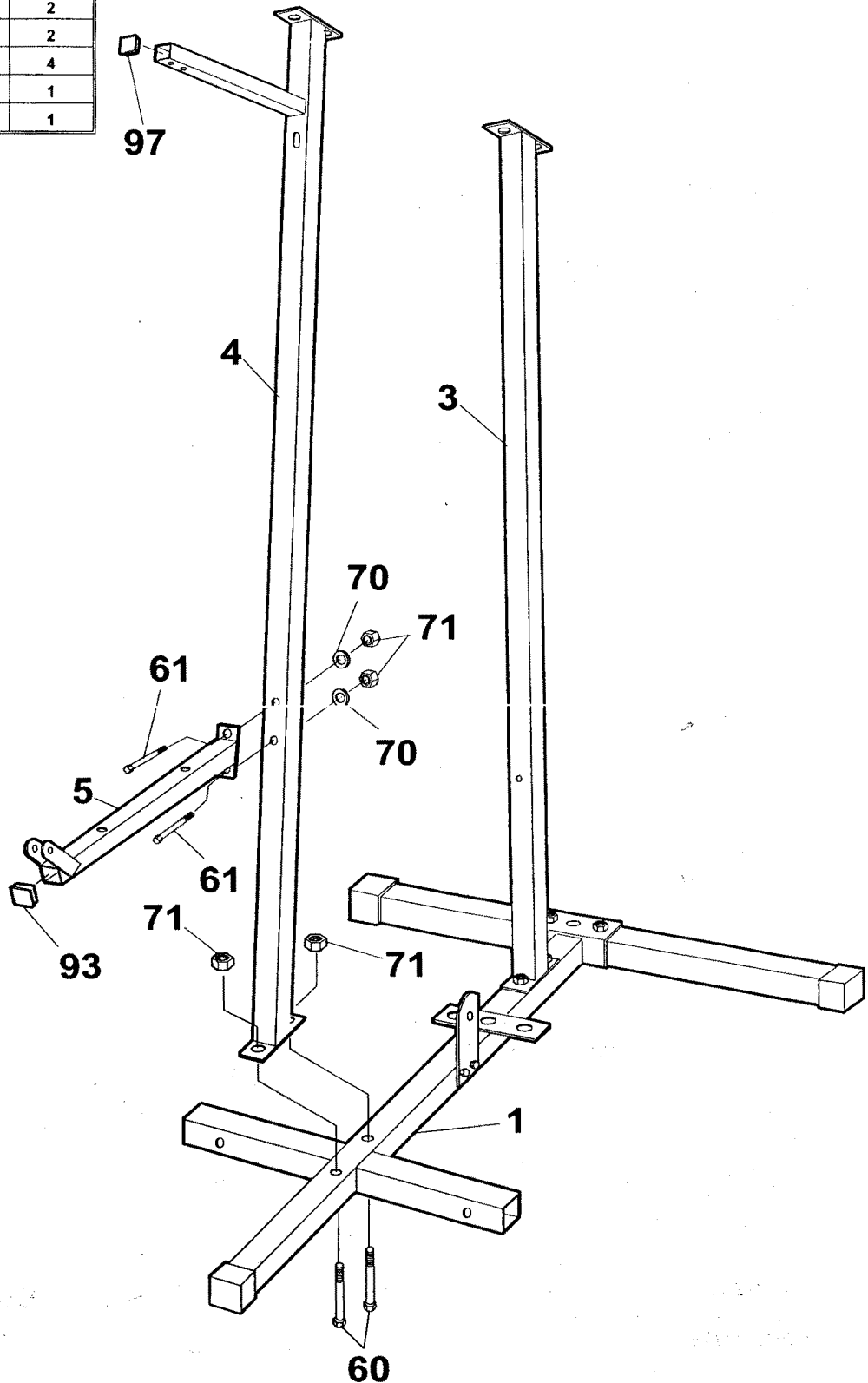



### STEP 3 REAR FRAME BRACE ASSEMBLY

PART NAME	QTY
61 5/16" X 2 1/2" HEX HEAD BOLT	1
62 5/16" X 2 3/4" HEX HEAD BOLT	1
70 5/16" FLAT WASHER	1
71 5/16" NYLON LOCK NUT	2

- Attach the REAR FRAME BRACE (7) to the REAR BASE (2) by bolting with a 5/16" X 2 1/2" HEX HEAD BOLT (61) up through the Rear Base and then through the Brace. Secure with a 5/16" NYLON LOCK NUT (71).
- Assemble the upper Brace to the REAR FRAME UPRIGHT (3) by first assembling a 5/16" FLAT WASHER (70) onto a 5/16" X 2 3/4" HEX HEAD BOLT (62) and bolting through the Upright and then the Brace.

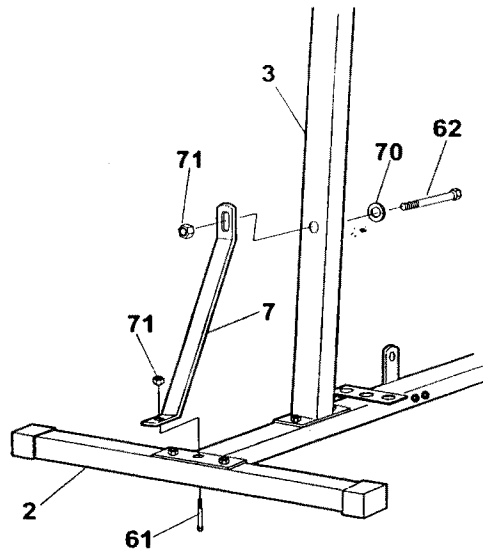

### STEP 4 TOP FRAME ASSEMBLY

PART NAME	QTY
62 5/16" X 2 3/4" HEX HEAD BOLT	5
63 5/16" X 3" HEX HEAD BOLT	1
70 5/16" FLAT WASHER	7
71 5/16" NYLON LOCK NUT	6
96 2" SQUARE PLASTIC INSERT CAP	2
105 1" O.D. X 1" LONG BUSHING	1

- Assemble the ARM PRESS BRACKET (9) to the top of the Welded Stopper Tube on the ARM PRESS UPRIGHT (4) by first assembling a 5/16" FLAT WASHER (70) and a 1" O.D. X 1" LONG BUSHING (105) onto a 5/16" X 3" HEX HEAD BOLT (63) and then bolting down through the Arm Press Bracket and then through the Welded Stopper Tube. Assemble on another 5/16" FLAT WASHER (70) and secure with a 5/16" NYLON LOCK NUT (71) only finger tight. (SEE DETAIL A)

- Attach the TOP FRAME (8) to the REAR FRAME UPRIGHT (3) by first assembling 5/16" FLAT WASHERS (70) onto two 5/16" X 2 3/4" HEX HEAD BOLTS (62) and then bolting down through the top of the Top Frame and then through the brackets of the Rear Frame Upright. Secure with 5/16" NYLON LOCK NUTS (71). Tighten only finger tight.

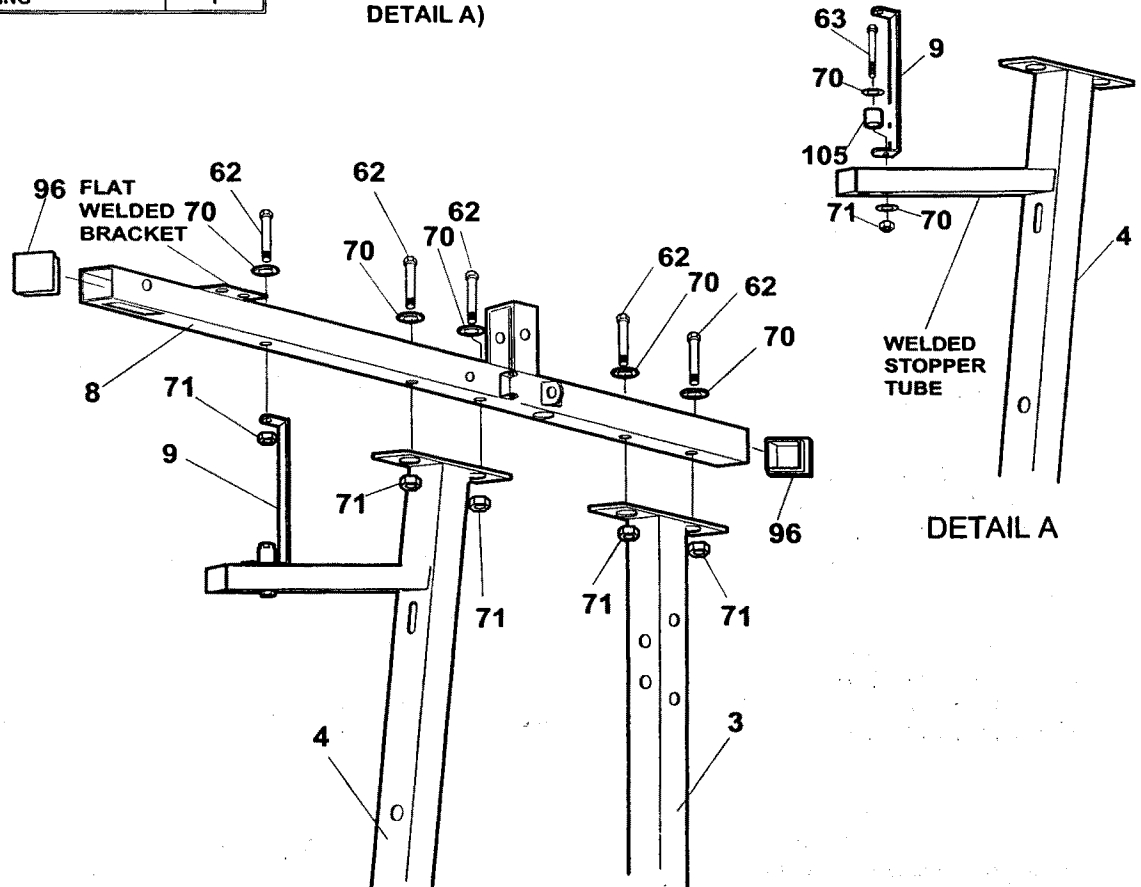

DETAIL A

- Attach the top of the **ARM PRESS BRACKET (9)** to the first hole behind the **Flat Welded Bracket** at the front of the **TOP FRAME (8)** by assembling a **5/16" FLAT WASHER (70)** onto a **5/16" X 2 3/4" HEX HEAD BOLT (62)** and bolting down through the top of the Frame and then through the Bracket. Assemble on a **5/16" NYLON LOCK NUT (71)** and tighten only finger tight.
- Assemble **5/16" FLAT WASHERS (70)** onto two **5/16" X 2 3/4" HEX HEAD BOLTS (62)** and attach the **TOP FRAME (8)** to the **ARM PRESS FRAME UPRIGHT (4)** by bolting down through the top of the Top Frame and then through the brackets of the Upright. Fasten with **5/16" NYLON LOCK NUTS (71)** and tighten only finger tight.

**TAKE THE TIME NOW TO TIGHTEN ALL BOLTS OF THE FRAME THAT WERE LEFT UNTIGHTENED FROM THE LAST 4 STEPS.**

**STEP 5 SEAT BRACE ASSEMBLY**

PART NAME	QTY
64 5/16" X 1" HEX HEAD BOLT	2
71 5/16" NYLON LOCK NUT	2
80 1/4" X 2 1/2" CARRIAGE BOLT	1
85 1/4" X 2" CARRIAGE BOLT	1
86 1/4" FLAT WASHER	1
87 1/4" NYLON LOCK NUT	1
95 2" SQUARE PLASTIC COVER CAP	2

- Assemble the **SEAT BRACE (10)** to the rear of the **SEAT FRAME (5)** by bolting with a **1/4" X 2 1/2" CARRIAGE BOLT (80)** down through a **SEAT MOUNTING PLATE (11)**, the Seat Frame, and then the Seat Brace. Secure with a **1/4" NYLON LOCK NUT (87)**.

- Attach the legs of the **SEAT BRACE (10)** to the **BASE "T" (1)** using **5/16" X 1" HEX HEAD BOLTS (64)** to bolt through the legs of the Seat Brace and then the Base "T". Fasten with **5/16" NYLON LOCK NUTS (71)**. (SEE DETAIL A.)

- Attach a **SEAT MOUNTING PLATE (11)** to the front hole of the **SEAT FRAME (5)** by bolting with a **1/4" X 2" CARRIAGE BOLT (85)** down through the Mounting Plate and then the Seat Frame. Assemble a **1/4" FLAT WASHER (86)** onto the bolt and secure with a **1/4" NYLON LOCK NUT (87)**.

- Cap the **Cross-member Tube** of the **BASE "T" (1)** with **2" SQUARE PLASTIC COVER CAPS (95)**.

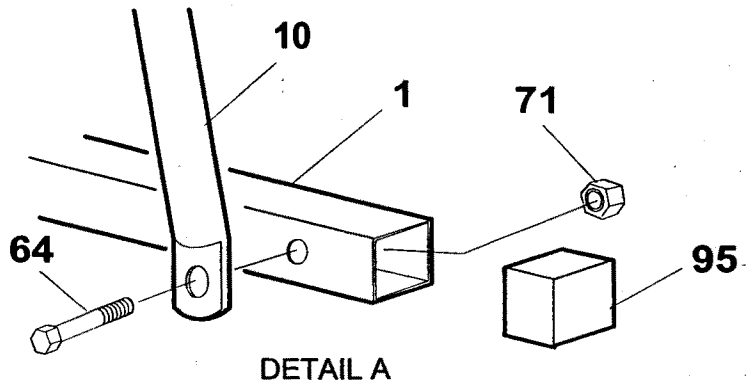
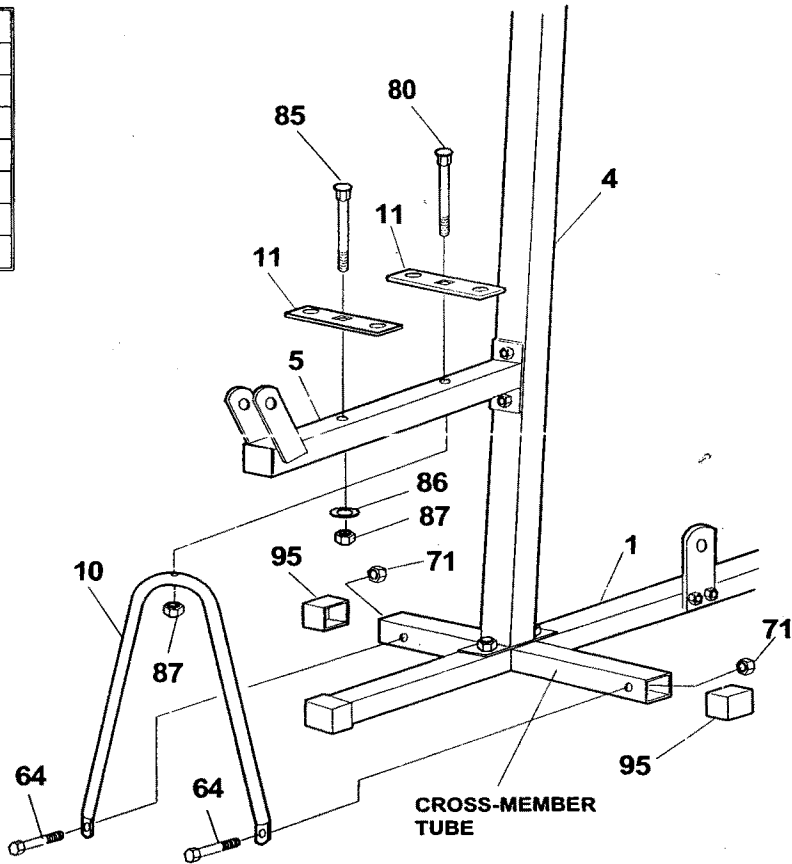

## STEP 6 WEIGHT STACK ASSEMBLY

PART NAME	QTY
110 END PLUG SELECTOR	1
114 LARGE RUBBER WASHER	2

» **CAUTION:** To aid in this step it is advised that you secure the assistance of a helper to assist in steadying of the Weight Plates as they are stacked.

Locate the **LARGE RUBBER WASHERS (114)** atop the welded Guide Rod Bracket on the **BASE "T" (1)**.

With the aid of your helper, begin stacking the **WEIGHT PLATES (12)** atop the Rubber Washers on the Guide Rod Bracket on the **BASE (1)**. Position the Weight Plates with the "Weider" embossing located to the rear of the unit and the Weight Selector Pin holes to the front of the unit.

Stack Weights one at a time until all but one are stacked on the Base.

Insert the **END PLUG SELECTOR (110)** into the bottom end of the **WEIGHT SELECTOR TUBE (13)**. Insert the Selector Tube into the center hole through the stack of Weight Plates and align the Pre-assembled Roll Pin of the Selector Tube with the groove in the top of the Weight Plate.

» **NOTE:** The Weight Selector Tube should insert completely through the stack of Weight Plates if they are in proper alignment with the welded Guide Rod Bracket on the Base. If it does not insert completely, adjust the Weight Stack positioning until it does.

When the **WEIGHT SELECTOR TUBE (13)** has been inserted fully into the Weight Stack, position the final **WEIGHT PLATE (12)** over the Selector Tube atop the Weight Stack.

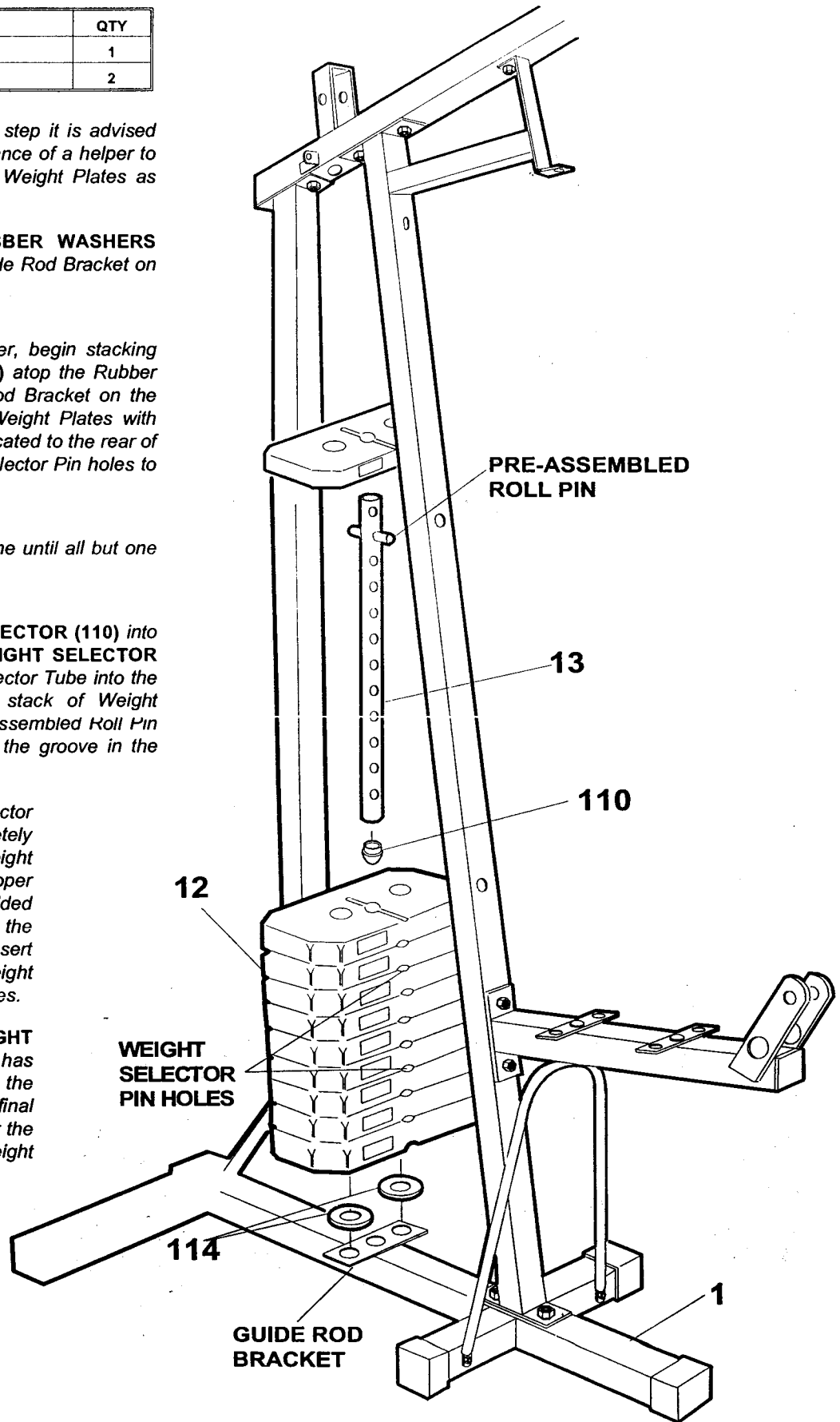

## STEP 7 GUIDE ROD ASSEMBLY

PART NAME	QTY
65 5/16" X 1 1/2" HEX HEAD BOLT	2
71 5/16" NYLON LOCK NUT	2
113 WEIGHT SELECTOR PIN	1

With the bolt holes of the **GUIDE RODS (14)** to the top, insert the Rods into the two remaining holes in the top of the Weight Stack (SEE **DETAIL A**).

Bolt the **GUIDE RODS (14)** to the front side of the welded brackets along the side of the **TOP FRAME (8)** using **5/16" X 1 1/2" HEX HEAD BOLT (65)** through the Rod, then the Bracket and fasten with **5/16" NYLON LOCK NUTS (71)**. (SEE **DETAIL B**)

Remove the **WEIGHT PLATE DECALS (120)** from the backing sheet and apply to the Weight Plates starting with 12.5 lbs. on the top Plate and increasing to 125 lbs. on the bottom Plate.

Insert the **WEIGHT SELECTOR PIN (113)** into the Weight Stack at a low setting to aid in future Cable assembly.

Remove the **STATION ONE DECAL (121)** from the backing sheet and affix it to the front side of the **ARM PRESS FRAME UPRIGHT (4)** about 4 inches below the **Welded Stop Tube**.

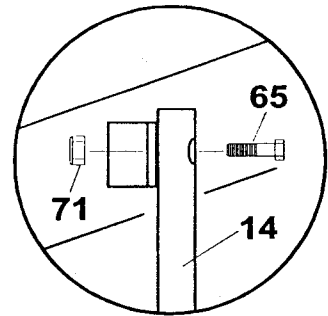

**DETAIL A**

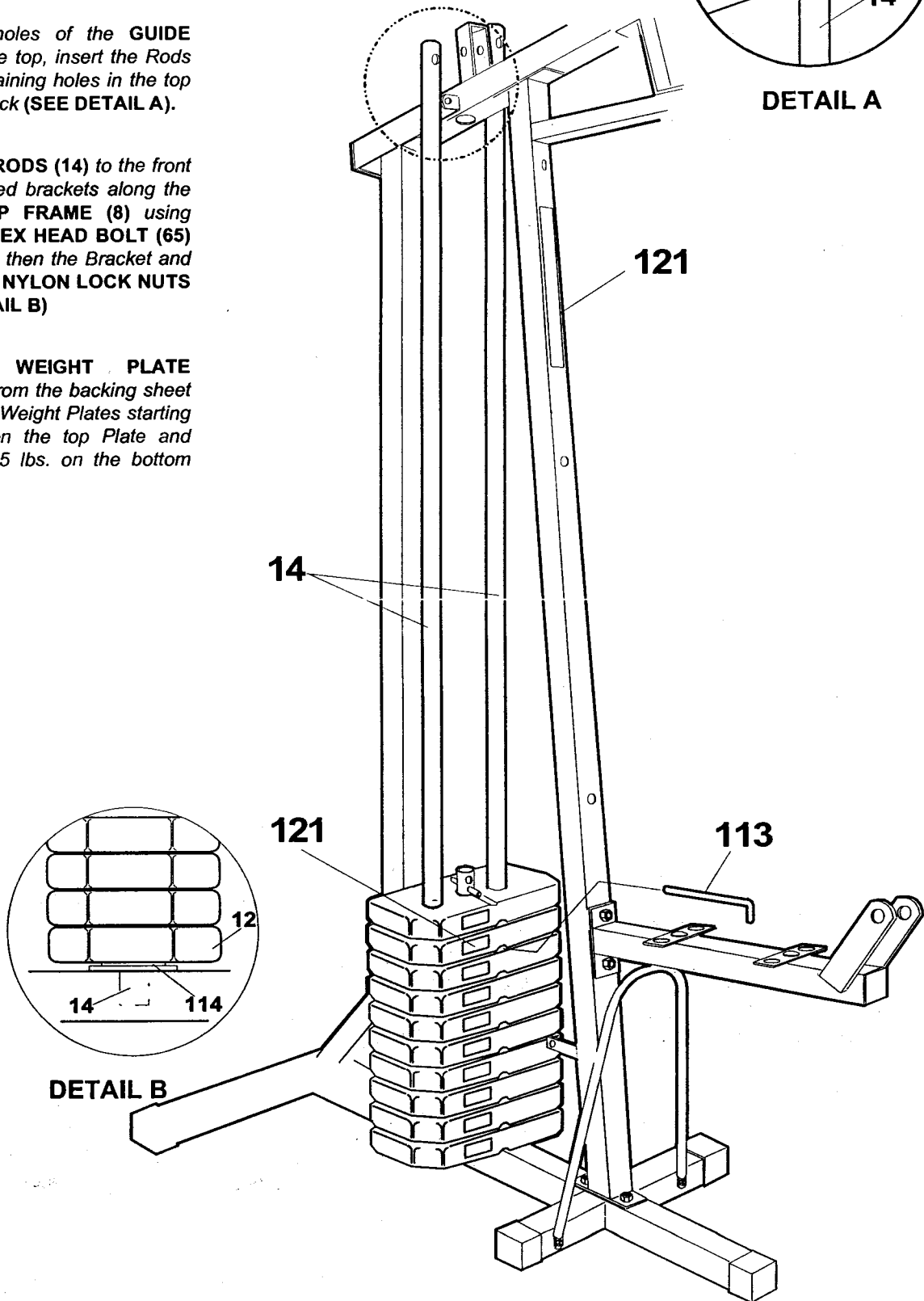

**DETAIL B**

## STEP 8 SEAT & BACKREST ASSEMBLY

PART NAME	QTY
81 1/4" X 3/4" MACHINE SCREW	4
82 1/4" X 2 1/2" MACHINE SCREW	2
86 1/4" FLAT WASHER	2

- Attach the SEAT (15) to the SEAT MOUNTING PLATES (11) on the SEAT FRAME (5) using 1/4" X 3/4" MACHINE SCREWS (81) and bolting up through the Mounting Plates and into the Seat.
- Attach the BACKREST (16) to the ARM PRESS FRAME UPRIGHT (4) by assembling 1/4" FLAT WASHERS (86) onto two 1/4" X 2 1/2" MACHINE SCREWS (82) and bolting through the back of the Upright and into the Seat.

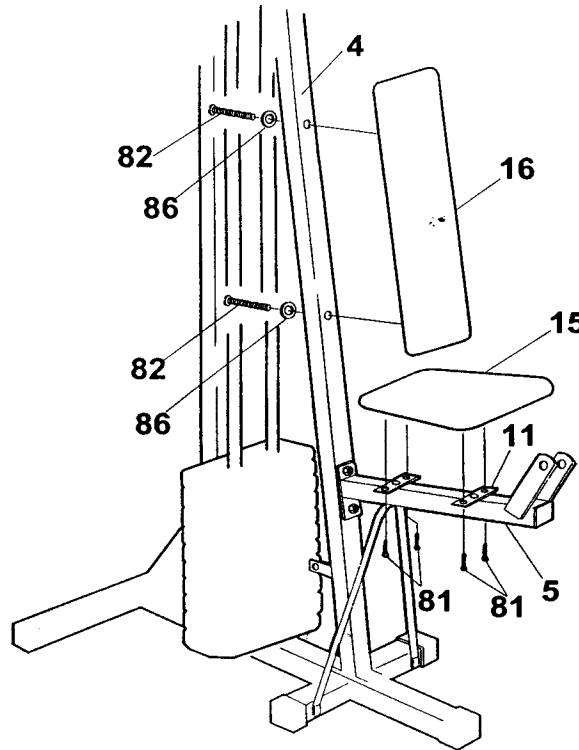

## STEP 9 LEG EXTENSION ASSEMBLY

PART NAME	QTY
60 5/16" X 2 1/4" HEX HEAD BOLT	1
71 5/16" NYLON LOCK NUT	1
97 1 1/4" SQUARE PLASTIC INSERT CAP	1
98 3/4" ROUND PLASTIC INSERT CAP	4

- Assemble the LEG EXTENSION TUBE (17) into the brackets of the SEAT FRAME (5) with a 5/16" X 2 1/4" HEX HEAD BOLT (60) and a 5/16" NYLON LOCK NUT (71). Cap the top of the Leg Extension Tube with a 1 1/4" SQUARE PLASTIC INSERT CAP (97).
- Press 3/4" ROUND PLASTIC INSERT CAPS (98) into the ends of the 3/4" X 12 1/2" PAD BAR (18) and the 3/4" X 13 1/2" PAD BAR (19).

» **NOTE:** To each Pad Bar, wipe a small amount of liquid dish detergent along the length of the Bar. This helps in the assembly of the Foam Pads. When the detergent dries, it acts as an adhesive.

- To one end of the 3/4" X 13 1/2" PAD BAR (19) press on one 2 1/4" X 6" FOAM ROLLER (21).
- Insert the PAD BAR (19) into the bracket of the SEAT FRAME (5) and assemble another FOAM ROLLER (21) onto the inserted tube end.
- To the end of the 3/4" X 12 1/2" PAD BAR (18) press on one 3" X 5 3/4" FOAM ROLLER (20).
- Assemble the PAD BAR (18) into a hole on the lower section of the LEG EXTENSION TUBE (17).
- Press another FOAM ROLLER (20) onto the inserted tube end.

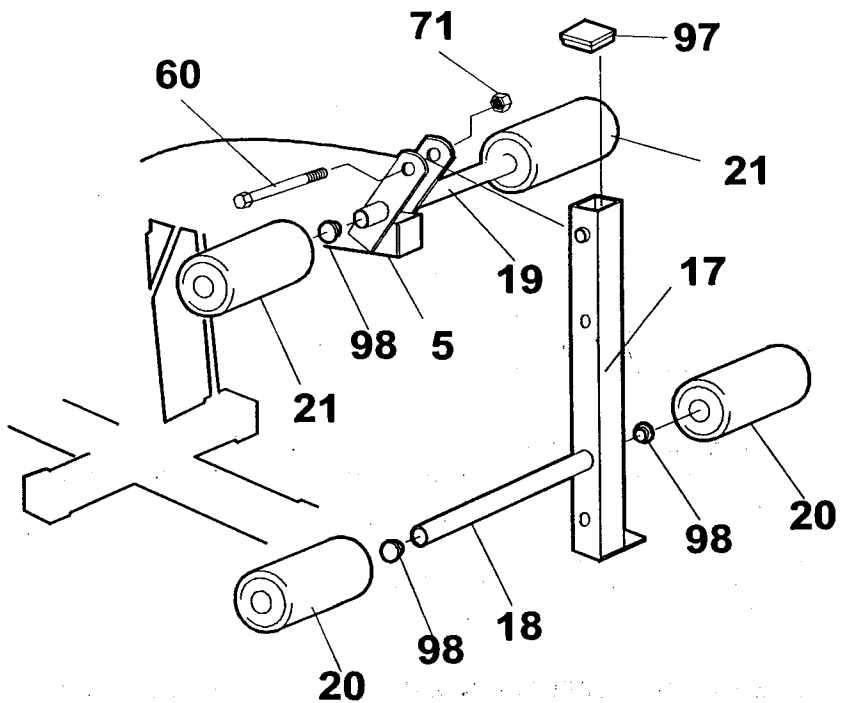

### STEP 10 ARM PRESS ASSEMBLY

PART NAME	QTY
81 1/4" X 3/4" MACHINE SCREW	4
87 1/4" NYLON LOCK NUT	4
88 #8 SHEET METAL SCREW	2

Press the two sections of the **ARM PRESS BUSHING (23)** onto the top of the **ARM PRESS ASSEMBLY (22)**. These Bushings will not snap tight to the surface so they will have to be held tight as complete assembly is placed on the **TOP FRAME (8)**.

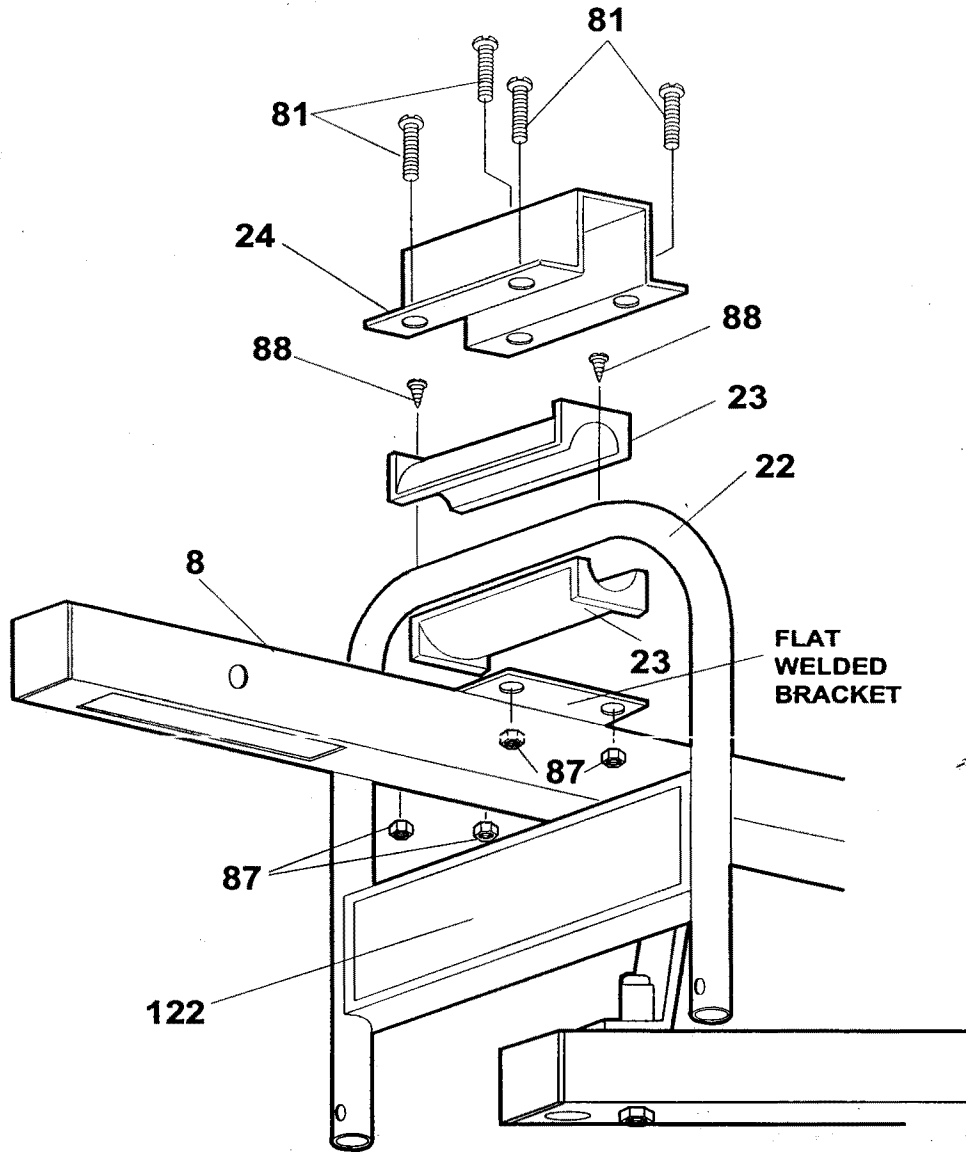

- Lift the Arm Press unit over the end of the **TOP FRAME (8)** and align on the Flat Welded Bracket.
- Press the **ARM PRESS CAP (24)** onto the top of the Arm Press unit aligning the bolt holes. **CAUTION:** Double check the Arm Press Bushing Sections to insure they are sitting squarely against the Bracket.
- Secure the **ARM PRESS CAP (24)** to the bracket by bolting with four **1/4" X 3/4" MACHINE SCREWS (81)** down through the top of the Arm Press Cap and then through the welded bracket on the Top Frame. Secure with **1/4" NYLON LOCK NUTS (87)**.
- Insert two **#8 SHEET METAL SCREWS (88)** into the holes located on the top of the Arm Press Assembly on both sides of the Arm Press Cap.
- Remove the **POWER STACK DECAL (122)** from the backing and adhere it onto the **ARM PRESS ASSEMBLY (22)**.

**STEP 11 ARM PRESS HANDLE ASSEMBLY**

PART NAME	QTY
66 5/16" X 2" HEX HEAD BOLT	2
70 5/16" FLAT WASHER	4
71 5/16" NYLON LOCK NUT	2
93 1 1/2" SQUARE PLASTIC INSERT CAP	4
99 1" ROUND PLASTIC INSERT CAP	2
106 3/8" LONG METAL SPACER	2

Press 1 1/2" SQUARE PLASTIC INSERT CAPS (93) into both ends of the PEC-DECK ARMS (25).

Wipe a small amount of liquid dish detergent onto the lower section of the PEC-DECK ARMS (25) and slide on a 3 1/4" X 7" FOAM ROLLER (30). Position the Rollers up about 8 inches from the Tube end.

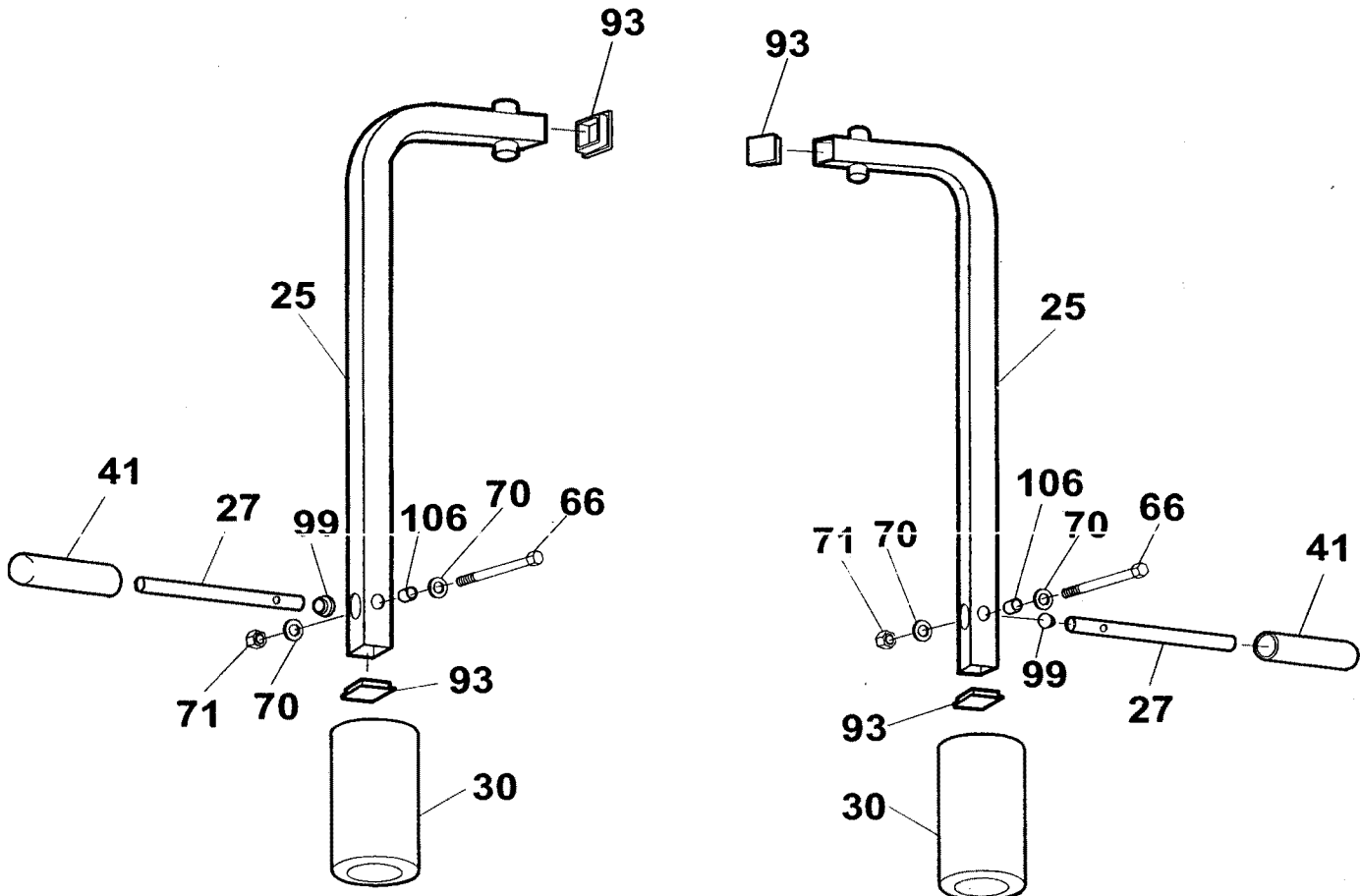

Cap only the inside ends of the ARM PRESS HANDLES (27) with 1" ROUND PLASTIC INSERT CAPS (99).

Insert the end of the Arm Press Handle with the holes into the PEC-DECK ARMS (25).

Rotate the Handle until the bolt holes align.

Assemble a 5/16" FLAT WASHER (70) and a 3/8" LONG METAL SPACER (106) onto a 5/16" X 2" HEX HEAD BOLT (66) and insert through the front of the Pec-Deck Arm and then through the hole in the Arm Press Handle. Attach another 5/16" FLAT WASHER (70) and secure with a 5/16" NYLON LOCK NUT (71).

Assemble 1" I.D. X 5" LONG PLASTIC GRIPS (41) onto the ends of the ARM PRESS HANDLES (27).

## STEP 12 PEC-DECK ARM ASSEMBLY

PART NAME	QTY
83 1/4" X 1 1/2" HEX HEAD BOLT	2
87 1/4" NYLON LOCK NUT	2
90 1 1/8" X 2 1/2" PLASTIC BUSHING	2
112 1 3/16" X 2" WASHER	2
115 PEC-DECK LOCK PIN 5/16" X 5"	2

- Slide a 1 1/8" X 2 1/2" PLASTIC BUSHING (90) onto each leg of the ARM PRESS ASSEMBLY (22).
- Insert a leg of the ARM PRESS ASSEMBLY (22) into the welded Tube on each PEC-DECK ARM (25).
- Place a 1 3/16" X 2" WASHER (112) onto the legs of the ARM PRESS ASSEMBLY (22). These Washers will not snap tight to the tube so they will have to be held tight as the assembly is completed.
- Secure this assembly by bolting with a 1/4" X 1 1/2" HEX HEAD BOLT (83) through the holes in the leg of the Arm Press Assembly. Fasten with 1/4" NYLON LOCK NUTS (87).
- Remove the ULTRA FORCE XT DECALS (123) from the backing and adhere to both sides of the TOP FRAME (8).

### ARM PRESS EXERCISES:

When doing Arm Press exercises, two PEC-DECK LOCKING PINS (115) should be pinned in Locking Pin positions "B" & "C". The Locking Pin should be pinned through the ARM PRESS ASSEMBLY (22) and then through the PEC-DECK ARMS (25). There should be NO pin in the center position, "A".

### BUTTERFLY EXERCISES:

When doing Butterfly exercises, insert a PEC-DECK LOCKING PIN (115) into Locking Pin position "A" through the ARM PRESS ASSEMBLY (22) and remove any Pins from Locking Pin positions "B" & "C".

### NOTE:

Locking Pins "B" & "C" should always be in place for all exercises except Butterfly exercises to keep Cables properly tensioned.

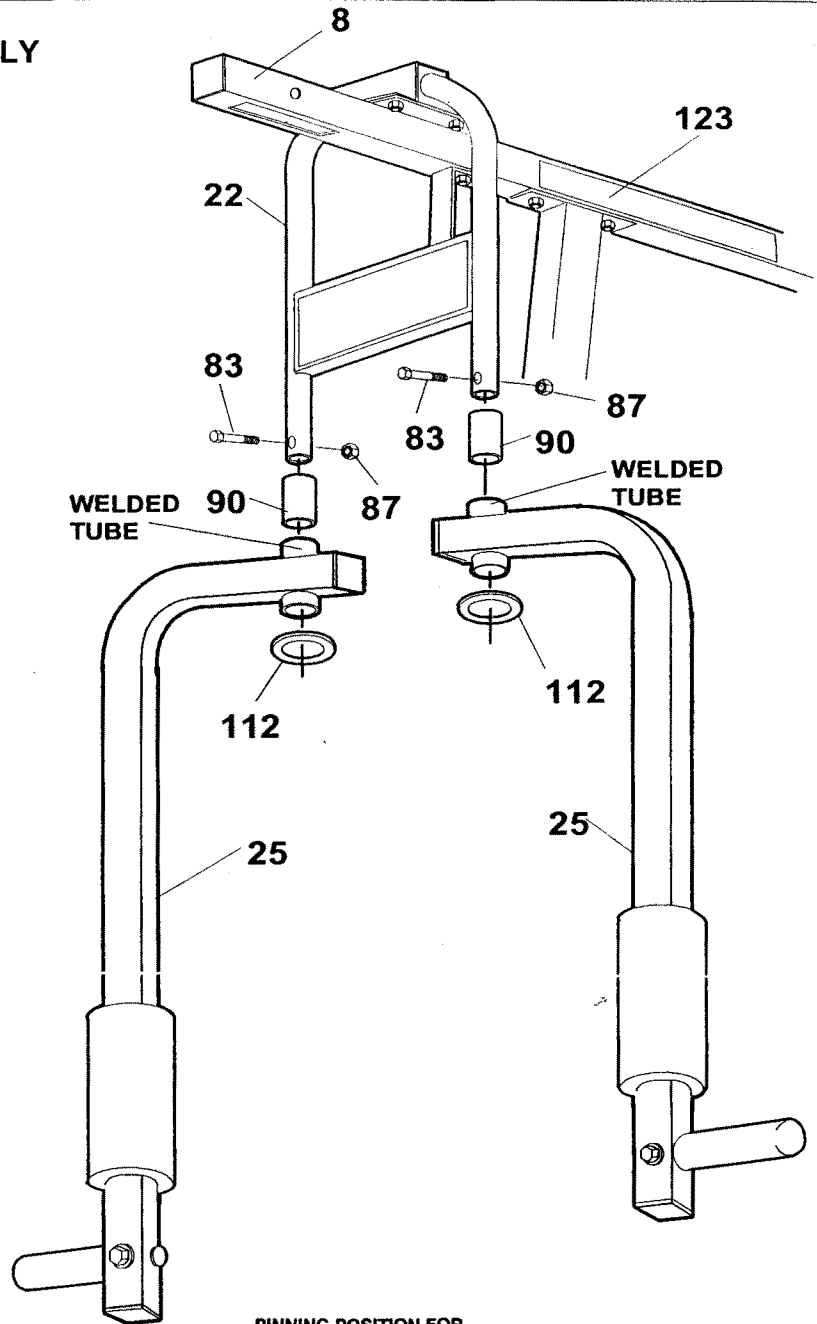

PINNING POSITION FOR BUTTERFLY EXERCISES

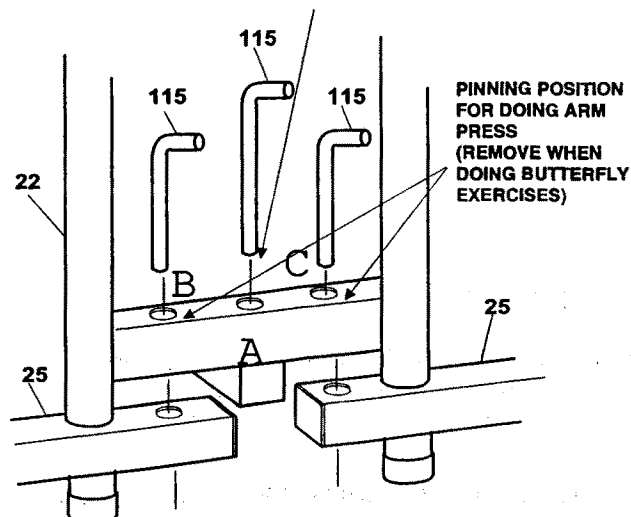

PINNING POSITION FOR DOING ARM PRESS (REMOVE WHEN DOING BUTTERFLY EXERCISES)



## STEP 13 BRACKET ASSEMBLIES

PART NAME	QTY
60 5/16" X 2 1/4" HEX HEAD BOLT	2
63 5/16" X 3" HEX HEAD BOLT	1
66 5/16" X 2" HEX HEAD BOLT	2
67 5/16" X 3 1/4" HEX HEAD BOLT	1
70 5/16" FLAT WASHER	3

- Attach the U-BRACKETS - 3 1/2" LONG (26) to the back of the PEC-DECK ARMS (25) by assembling a 5/16" FLAT WASHER (70) onto two 5/16" X 2 1/4" HEX HEAD BOLTS (60) and bolting through the front of the Pec-Deck Arms at the hole locations near the welded Tube and then bolt through the U-Bracket. Secure tightly with 5/16" NYLON LOCK NUTS (71).

- Assemble the PULLEY BRACKET (28) to the U-BRACKETS (26) by bolting with a 5/16" X 2" HEX HEAD BOLT (66) down through the top of the U-Bracket and then through the Pulley Bracket. Fasten with 5/16" NYLON LOCK NUT (71).

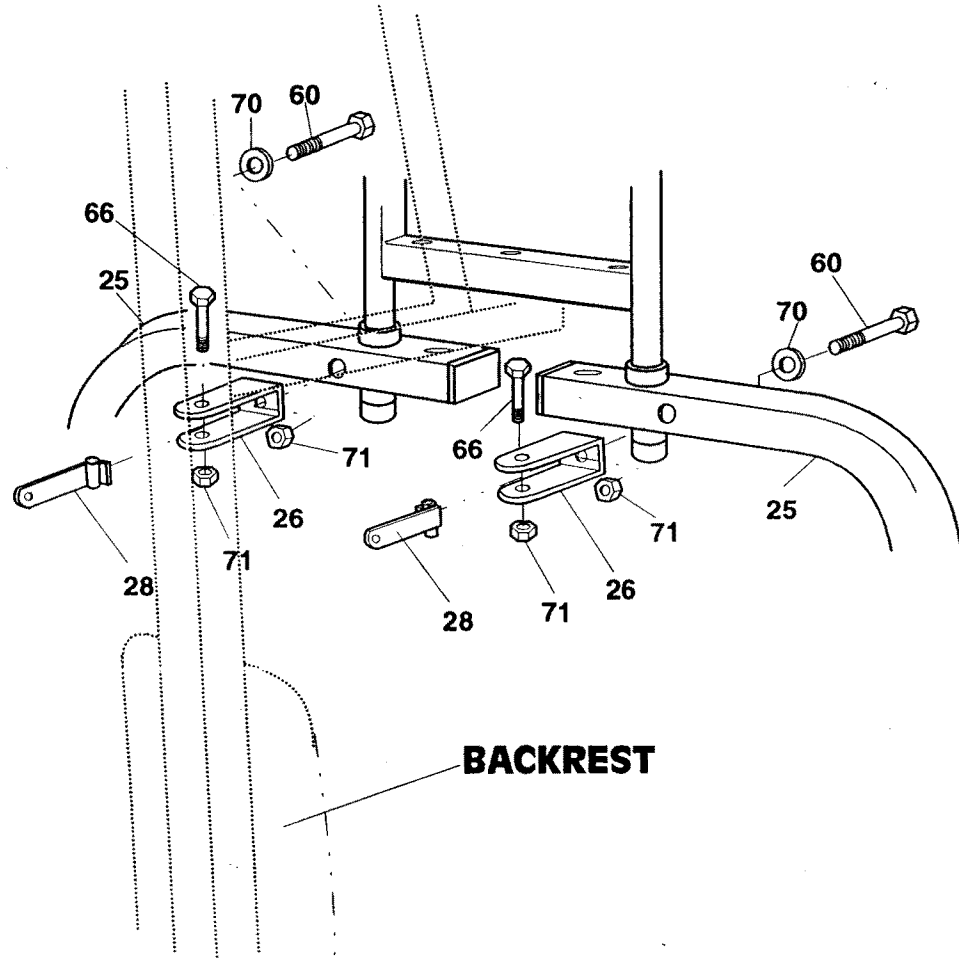

**BACKREST**

- Attach a U-BRACKET - 3" LONG (32) to the front of the ARM PRESS FRAME UPRIGHT (4) by bolting with a 5/16" X 3" HEX HEAD BOLT (63) through the U-Bracket and then through the Upright. Assemble a 5/16" FLAT WASHER (70) onto the Bolt and fasten with a 5/16" NYLON LOCK NUT (71) only to the point that the Nut is flush with the end of the Bolt. This is necessary to allow some movement of the U-Bracket.

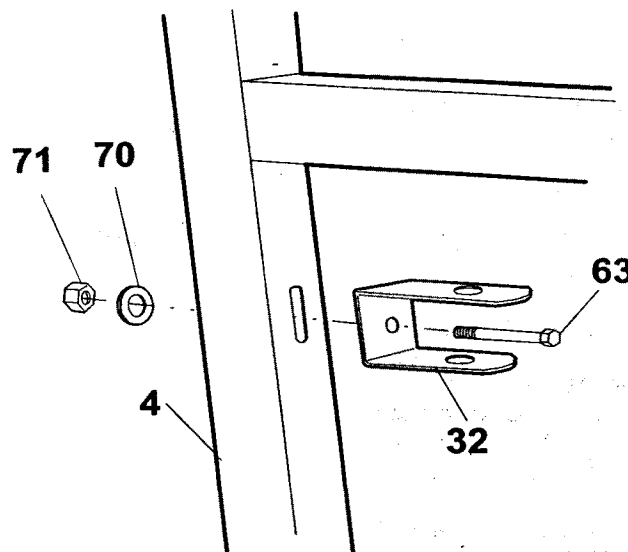

- Assemble a **PULLEY TRAP BRACKET (29)** to the **Welded U-Bracket** on the side of the **TOP FRAME (8)** using a **5/16" X 3" HEX HEAD BOLT (67)** to bolt down through the top of the U-Bracket and then through the **Pulley Trap Bracket**. Secure with a **5/16" NYLON LOCK NUT (71)**.

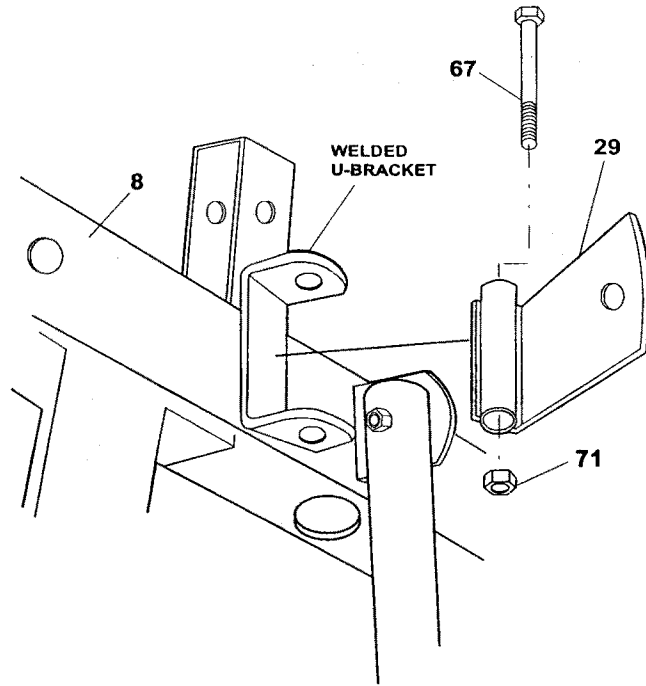

**STEP 14 UPPER PULLEYS & CABLE ASSEMBLY**

PART NAME	QTY
63 5/16" X 3" HEX HEAD BOLT	1
70 5/16" FLAT WASHER	2
71 5/16" NYLON LOCK NUT	1
72 3/8" X 2 1/2" HEX HEAD BOLT	1
73 3/8" X 1 3/4" HEX HEAD BOLT	5
78 3/8" FLAT WASHER	2
79 3/8" NYLON LOCK NUT	6
91 1/2" X 1/2" ZINC BUSHING	1
92 1/2" METAL SPACER	2

- Locate the **PEC-DECK CABLE (37)**. The Pec-Deck Cable is 127 inches long and has a Rubber Stopper Ball on one end and a loop on the other end.
- Insert the **PEC-DECK CABLE (37)** up through the slot in the front of the **TOP FRAME (8)** so that the Rubber Stopper Ball is to the front and underneath the Top Frame.
- Drape the **PEC-DECK CABLE (37)** over a **4 1/2" PULLEY (50)** and assemble it into the slot using a **3/8" X 2 1/2" HEX HEAD BOLT (72)**, **3/8" FLAT WASHER (78)**, and a **1/2" METAL SPACER (92)**. Insert the Bolt with the Spacer and Washer through the Frame and the Pulley and then assemble another **1/2" METAL SPACER (92)** and a **3/8" FLAT WASHER (78)** and fasten with a **3/8" NYLON LOCK NUT (79)**.

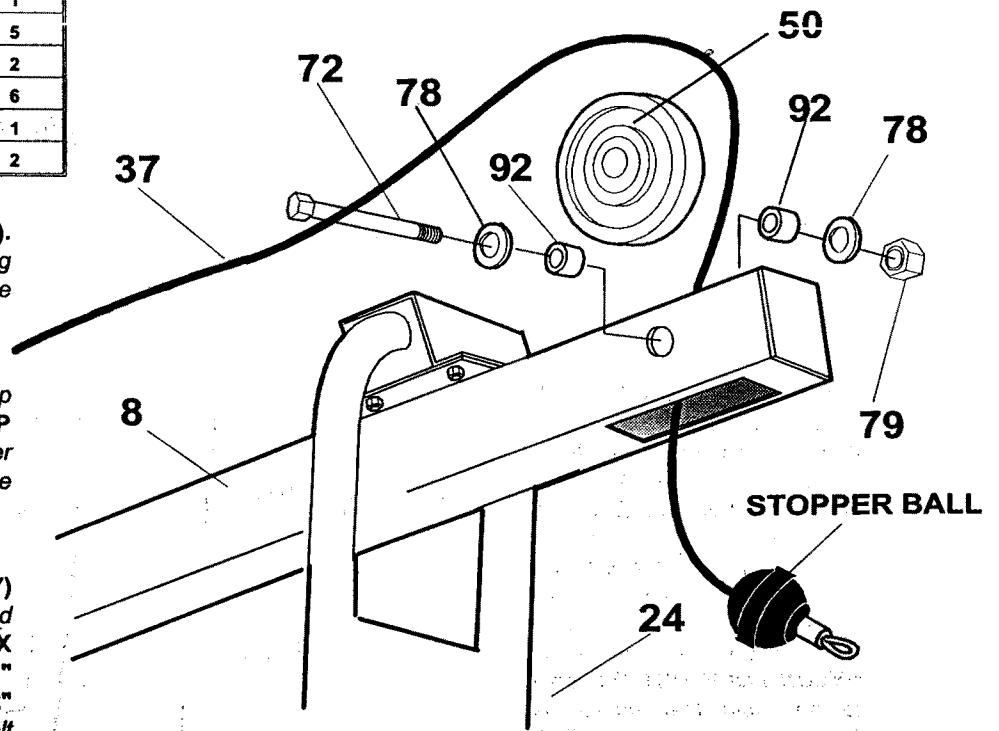

Bring the Cable back down across the top of the Top Frame and through the welded Pulley Bracket. Insert the entire Cable down through the Cable access hole located behind the Welded Bracket.

Fit the Cable over a 3 1/2" PULLEY (51) and bolt into the Welded Bracket. Secure with a 3/8" X 1 3/4" HEX HEAD BOLT (73) and a 3/8" NYLON LOCK NUT (79).

Leave some of the Cable draped down between the Guide Rods. This area of the Cable will be assembled later. The amount of the Cable left draped is not critical as you will be pulling the slack out of the Cable once the Cable is fastened.

Move to the left-hand side of the unit.

Bring the PEC-DECK CABLE (37) up and set into a 3 1/2" PULLEY (51).

Trap the Cable into the groove of the Pulley using a CABLE TRAP BRACKET (42) (THE CABLE TRAP BRACKET WILL BE POSITIONED AT APPROXIMATELY A 45 DEGREE ANGLE) and bolt assembly to the PULLEY BRACKET (29) that is bolted to the bracket on the side of the Top Frame using a 3/8" X 1 3/4" HEX HEAD BOLT (73) and a 3/8" NYLON LOCK NUT (79).

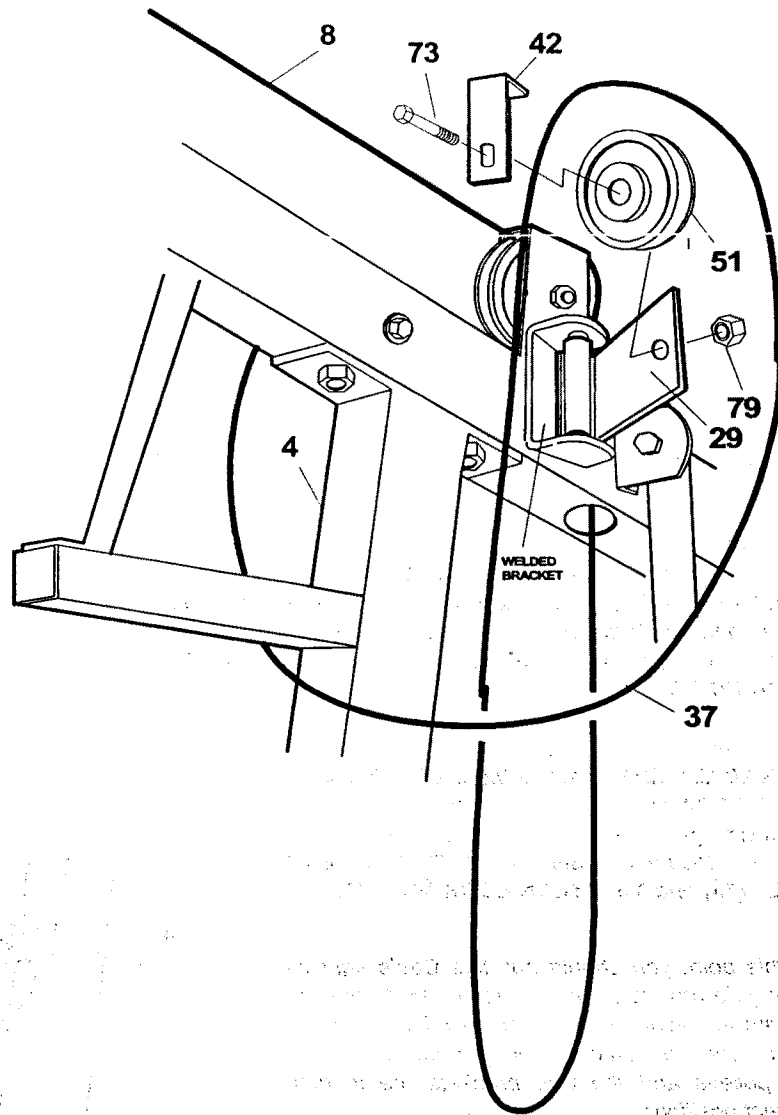
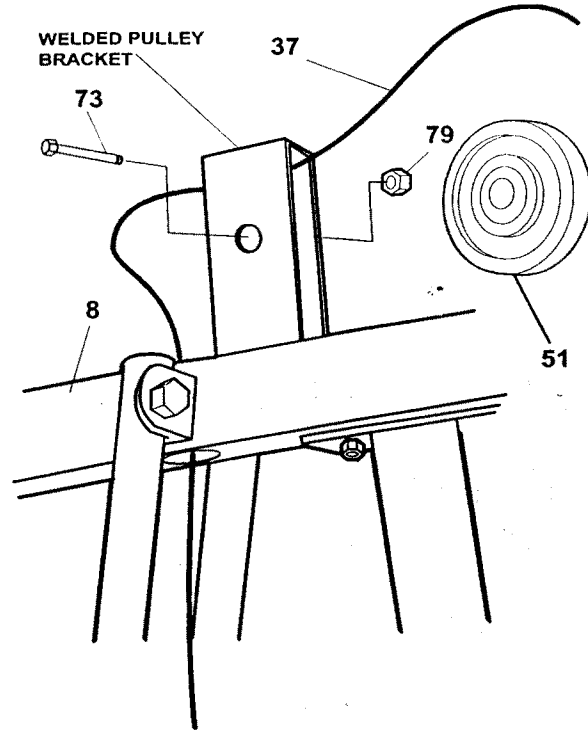

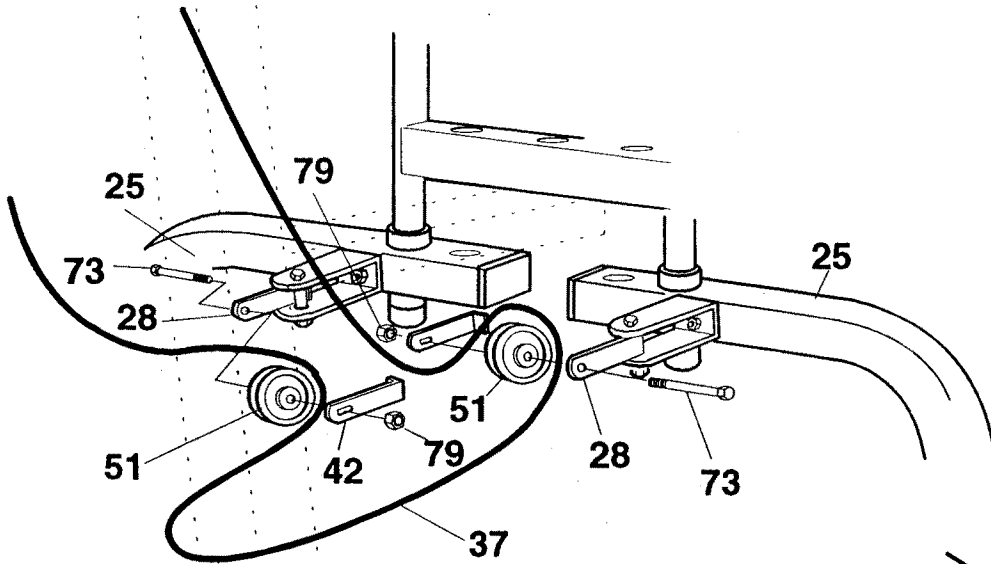

Next, fasten 3 1/2" PULLEYS (51) to PULLEY BRACKETS (28) while trapping the Cable into the Pulley with CABLE TRAP BRACKETS (42). Again the Trap Brackets will be positioned at a 45 degree angle facing toward the front of the unit. Bolt the assemblies to the PULLEY BRACKETS (28) using 3/8" X 1 3/4" HEX HEAD BOLTS (73) and 3/8" NYLON LOCK NUTS (79).

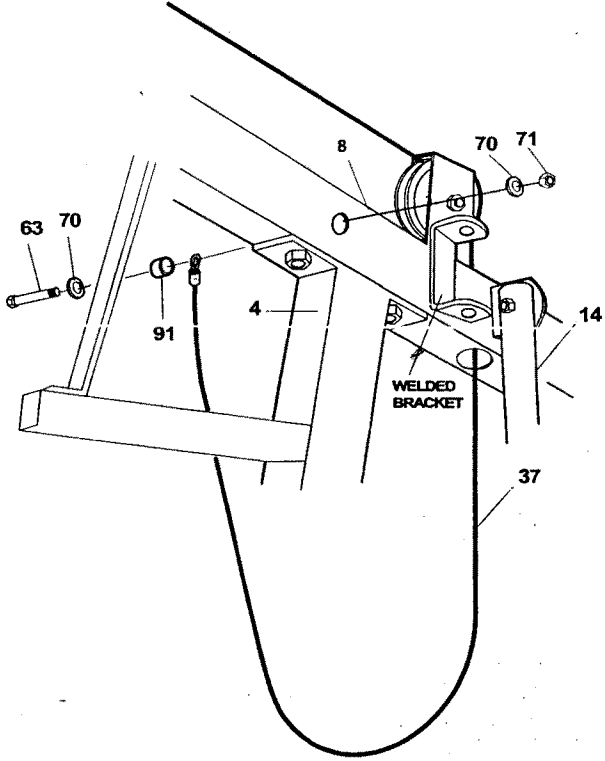

Moving to the right-hand side of the unit, fasten the loop-end of the Cable to the side of the Top Frame in the hole located in front of the Arm Press Frame Upright. Place a 1/2" X 1/2" ZINC BUSHING (91) into the loop of the Cable. Place a 5/16" FLAT WASHER (70) onto a 5/16" X 3" HEX HEAD BOLT (63) and insert through the assembled bushing and Cable and on through the Top Frame hole securing with another 5/16" FLAT WASHER (70) and a 5/16" NYLON LOCK NUT (71).

Move back to the center of the unit. Into the U-BRACKET (26) bolted to the front of the ARM PRESS FRAME UPRIGHT (4) assemble a 4 1/2" PULLEY (50) trapping the Cable behind the Pulley. Secure with 3/8" X 1 3/4" HEX HEAD BOLT (73) and 3/8" NYLON LOCK NUT (79).

At this point you should pull this Cable tight by pulling downward on the section of the Cable you left draped down in an earlier step. Make sure all of the Cable is seated properly in the grooves of the pulleys and the trap brackets are in their correct positions.

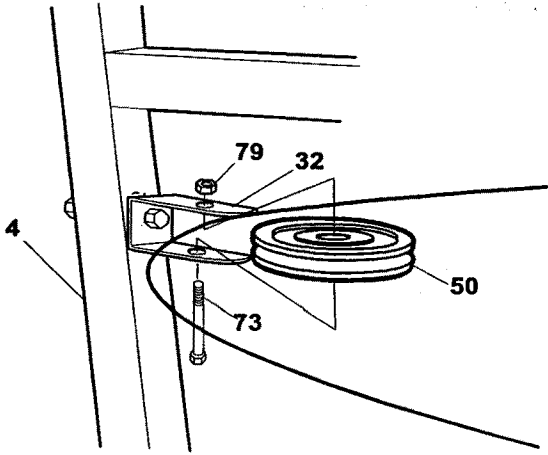

**STEP 15 LOWER PULLEY AND CABLE ASSEMBLY**

PART NAME	QTY
65 5/16" X 1 1/2" HEX HEAD BOLT	1
66 5/16" X 2" HEX HEAD BOLT	1
68 5/16" X 3/4" HEX HEAD BOLT	1
70 5/16" FLAT WASHER	3
71 5/16" NYLON LOCK NUT	3
73 3/8" X 1 3/4" HEX HEAD BOLT	4
74 3/8" X 2 3/4" HEX HEAD BOLT	1
78 3/8" FLAT WASHER	2
79 3/8" NYLON LOCK NUT	5
84 1/4" X 1 3/4" HEX HEAD BOLT	1
87 1/4" NYLON LOCK NUT	1

Locate the **WEIGHT STACK CABLE (38)**. The Weight Stack Cable is 79 inches long and has a loop on each end.

Attach the **WEIGHT STACK CABLE (38)** by inserting a loop of the cable into the end of the **WEIGHT SELECTOR TUBE (13)** and fasten with a **5/16" 1 1/2" HEX HEAD BOLT (65)** and **5/16" NYLON LOCK NUT (71)**.

- Assemble the **PLASTIC WEIGHT GUIDE BRACKET (31)** onto the top of the Weight Stack and fit around the top of the **WEIGHT SELECTOR TUBE (13)**. (SEE DETAIL - WEIGHT GUIDE BRACKET)
- Bring the cable up and make the dual pulley assembly that hangs between the Guide Rods (SEE DETAIL A).
- Using two **4 1/2" PULLEYS (50)**, trap the **WEIGHT STACK CABLE (38)** and the **PEC-DECK CABLE (37)**. Insert two **3/8" X 1 3/4" HEX HEAD BOLTS (73)** through a **PULLEY CONNECTOR PLATE (52)** and then through the two **4 1/2" Pulleys**. Add the second **PULLEY CONNECTOR PLATE (52)** and secure the assembly with two **3/8" NYLON LOCK NUTS (79)**. (SEE DETAIL A)
- Bring the Weight Selector Cable down and fit into a **3 1/2" PULLEY (51)**. Using a **3/8" x 1 3/4" HEX HEAD BOLT (73)**, bolt a **CABLE TRAP BRACKET (42)** and the Pulley to the bolted **PULLEY PLATE (6)** on the side of the **BASE "T" (1)** and secure with a **3/8" NYLON LOCK NUT (79)**. The Cable Trap bracket should be positioned so that it is facing toward the floor.
- Bolt **BENT PULLEY BRACKETS (43)** to the loop end of the Weight Selector Cable with a **5/16" X 3/4" HEX HEAD BOLT (68)** and **5/16" NYLON LOCK NUT (71)**.
- Locate the **LEG EXTENSION CABLE (39)**. The Leg Extension Cable is 49" long and has a loop on one end and a Rubber Ball Stop and Sliding Cable Clamp on the other end.
- Connect the Leg Extension Cable to the upper section of **LEG EXTENSION TUBE (17)**. Place a **5/16" FLAT WASHER (70)** onto **5/16" X 2" HEX HEAD BOLT (66)** and insert through the loop-end of the Leg Extension Cable. Place another **5/16" FLAT WASHER (70)** onto the bolt and insert the assembly through the hole in the Leg Extension Tube. Secure with another **5/16" FLAT WASHER (70)** and a **5/16" NYLON LOCK NUT (71)**.
- Bring the Leg Extension Cable toward the rear and around a **3 1/2" PULLEY (51)** and bolt the pulley between the **BENT PULLEY BRACKETS (43)** using a **3/8" x 1 3/4" HEX HEAD BOLT (73)** and **3/8" NYLON LOCK NUT (79)**. Fit a **1/4" X 1 3/4" HEX HEAD BOLT (84)** into the hole in the Bent Pulley Brackets that falls behind the Pulley and secure with a **1/4" NYLON LOCK NUT (87)**. This bolt acts as a Cable Trap. (SEE DETAIL B)
- Bring the Leg Extension Cable forward and assemble onto the bottom of the Leg Extension Tube. so the cable is trapped under a **3 1/2" PULLEY (51)**. Place a **3/8" X 2 3/4" HEX HEAD BOLT (74)** into the **3 1/2" Pulley** and then through a **3/8" FLAT WASHER (78)** and attach assembly to the Leg Extension Tube trapping the Cable under the Pulley and secure with a **3/8" FLAT WASHER (78)** and **3/8" NYLON LOCK NUT (79)**. (SEE DETAIL C)
- Checking to see that all cables are seated in the Pulley grooves, pull the Leg Extension Cable forward so all the slack is taken out of the cable system. Slide the rubber ball stopper back against the leg extension tube and snug the sliding cable clamp firmly against the the rubber ball stopper and tighten the hex bolt on the clamp securely. (SEE DETAIL C) With use the cables will stretch and you may have to re-set the cable clamp to take out any slack that develops.

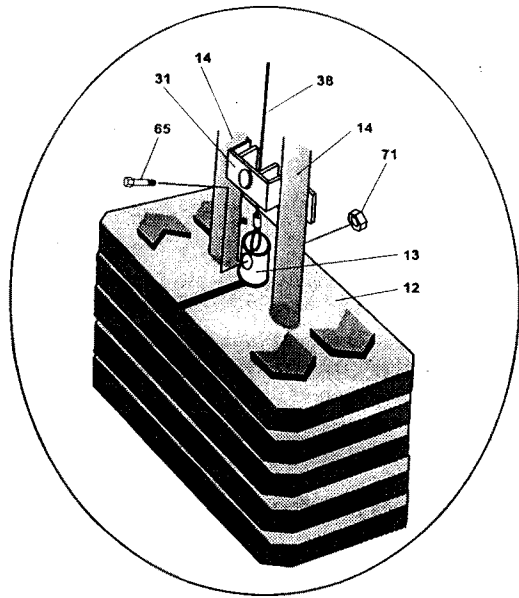

DETAIL - WEIGHT GUIDE BRACKET

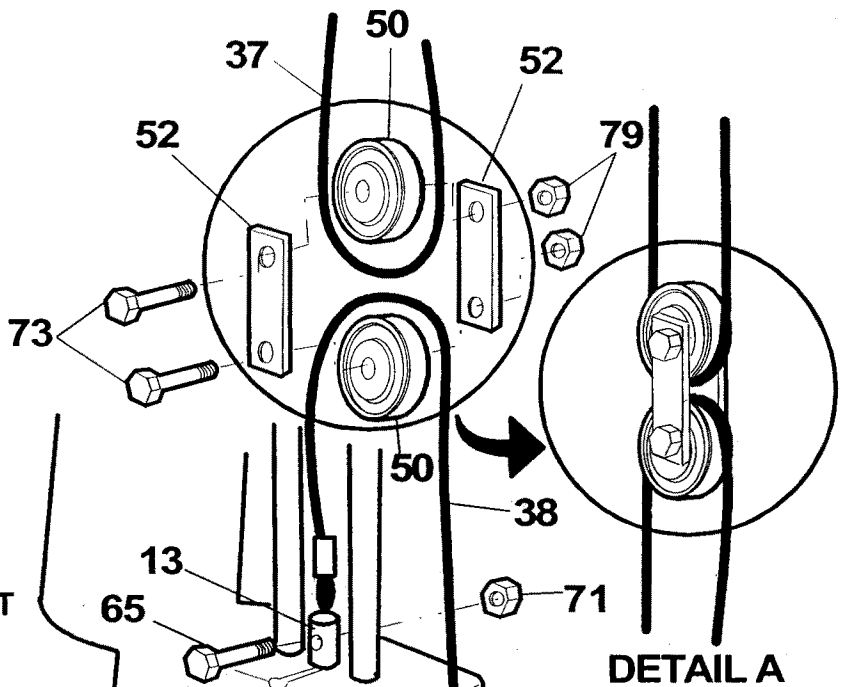

DETAIL A

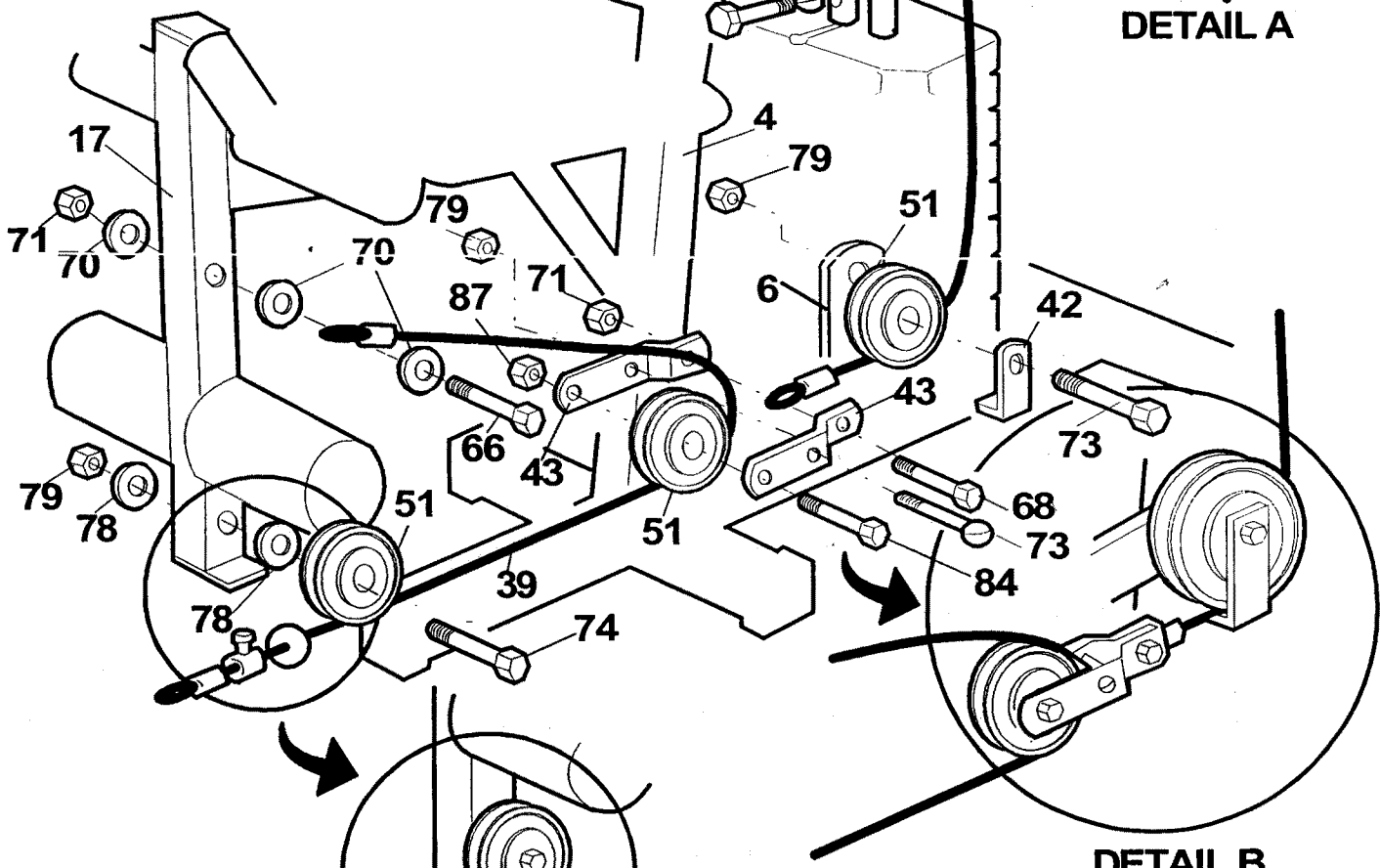

DETAIL B

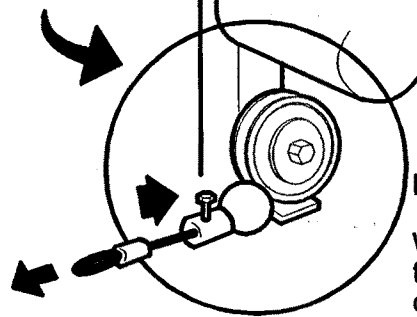

DETAIL C

LEG EXTENSION CABLE

When assembling the Leg Extension Cable, make sure the end of the cable that is bolted to the pulley at the base of the Leg Extension has the crimped ferrule at the very end, then the sliding cable clamp with the hex bolt, and then the rubber ball stopper, IN THAT ORDER. If this order is not correct, then you must slide the sliding cable clamp and rubber stop to the opposite end. SEE ILLUSTRATION!

## STEP 16 LAT BAR

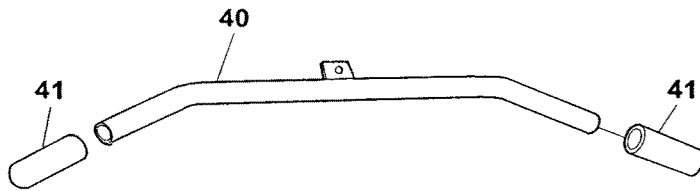

To the ends of the LAT BAR (40), assemble 1" I.D. X 5" PLASTIC GRIPS (41).

To use the Lat Bar, connect to the Cable at the Top Frame with LATCH HOOK (89). This Bar is used to do all Lat Pull-Down Exercises.

## NOTICE

TO PREVENT DAMAGE TO CABLE, RE-ADJUST STOPPER BALL & ADJUSTING FERRULE TO REMOVE ANY EXCESS SLACK THAT MAY DEVELOP IN CABLE SYSTEM.

TO ADJUST: LOOSEN SET SCREW IN ADJUSTING FERRULE. SLIDE TIGHTLY AGAINST LOW PULLEY.

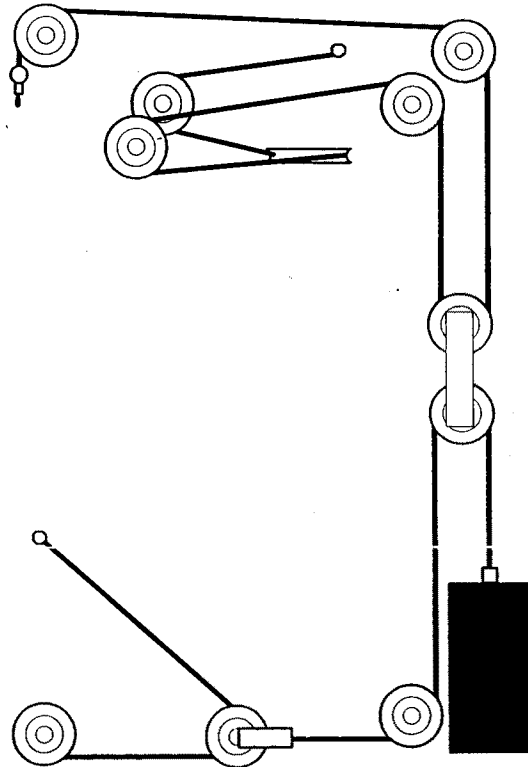
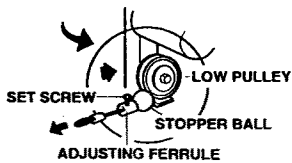

ENTIRE CABLE ROUTING DRAWING

## **EXERCISE FREQUENCY**

To maintain or improve your condition, you must workout 2-3 times per week following the pattern described above. A day of rest between workouts is recommended. After several months of exercise, the number of workouts can be

---

## **SUGGESTED STRETCHES**

The following stretches provide a good warm-up, or cool-down. Move slowly as you stretch - never bounce.

### **HAM STRING STRETCH**

Sit with one leg extended. Bring the sole of the opposite foot toward you, resting it against the extended leg's inner thigh. Stretch toward your toe as far as possible, hold for 15 counts, then relax. Repeat three times for both legs.

**stretches: Hamstrings, Lower Back and Groin**

### **INNER THIGH STRETCH**

Sit with the soles of your feet together and knees pointing outward. Pull your feet as close into the groin area as possible. Hold for 15 counts, then relax. Repeat three times.

**stretches: Quadriceps, Hip Muscles**

### **TOE TOUCHES**

Standing with your knees bent slightly, slowly bend forward from the hips. Allow your back and shoulders to relax as you stretch down toward your toes. Go as far as you can and hold for 15 counts, then relax. Repeat three times.

**stretches: Hamstrings, Back of Knees, Back**

### **QUADRICEPS STRETCH**

With one hand against a wall for balance, reach behind you and pull up your foot. Bring your heel as close to your buttocks as possible. Hold for 15 counts. Repeat.

**stretches: Quadriceps, Hip Muscles**

### **CALF/ACHILLES STRETCH**

With one leg in front of the other and arms out, lean against the wall. Keep your back leg straight and back foot flat on the ground; then bend the front leg and lean forward by moving your hips toward the wall. Hold, then repeat on the other side. To cause even further stretching of the Achilles tendons, slightly bend back leg as well.

**stretches: Calves, Achilles Tendons, and Ankles**

