

WEIDERPRO™

450 L

Model No. 831.15948.0

Serial No. _____

Write the serial number in the space above for reference.

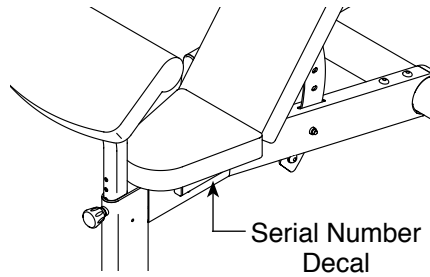

- Assembly
- Operation
- Maintenance
- Part List and Drawing

Sears, Roebuck and Co.
Hoffman Estates, IL 60179

CAUTION

Read all precautions and instructions in this manual before using this equipment. Keep this manual for future reference.

WEIGHT BENCH User's Manual

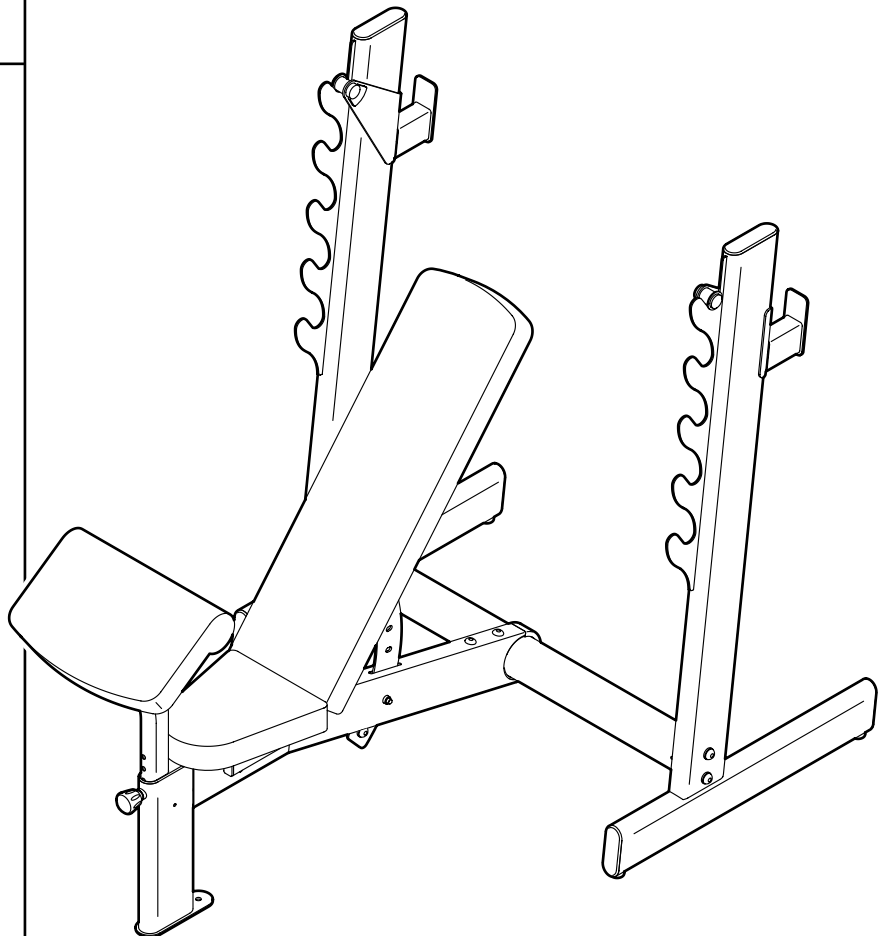
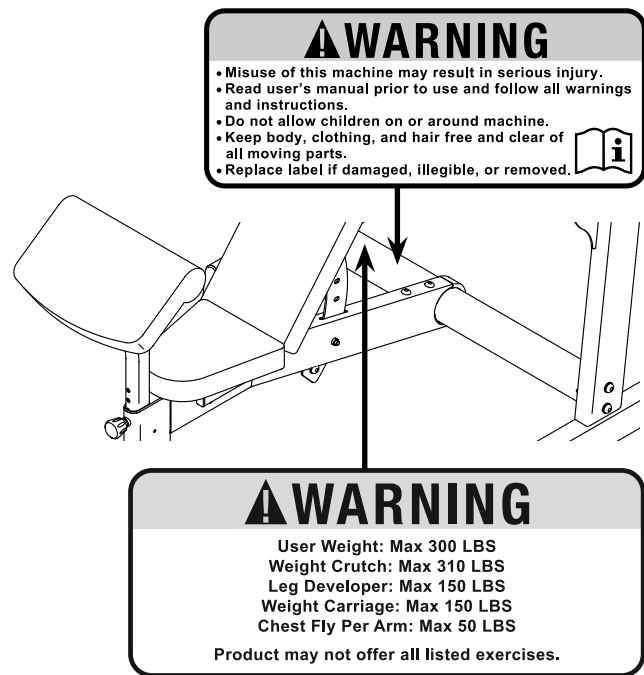

TABLE OF CONTENTS

WARNING DECAL PLACEMENT	2
IMPORTANT PRECAUTIONS	3
BEFORE YOU BEGIN	4
PART IDENTIFICATION CHART	5
ASSEMBLY	6
ADJUSTMENT	11
EXERCISE GUIDELINES	13
PART LIST	14
EXPLODED DRAWING	15
HOW TO ORDER REPLACEMENT PARTS	Back Cover
90 DAY FULL WARRANTY	Back Cover

WARNING DECAL PLACEMENT

This drawing shows the location(s) of the warning decal(s). **If a decal is missing or illegible, call 1-877-992-5999 and request a free replacement decal. Apply the decal in the location shown.**
Note: The decal(s) may not be shown at actual size.



IMPORTANT PRECAUTIONS

⚠️ WARNING: To reduce the risk of serious injury, read all important precautions and instructions in this manual and all warnings on your weight bench before using your weight bench. Sears assumes no responsibility for personal injury or property damage sustained by or through the use of this product.

1. It is the responsibility of the owner to ensure that all users of the weight bench are adequately informed of all precautions.
2. Before beginning any exercise program, consult your physician. This is especially important for persons over age 35 or persons with pre-existing health problems.
3. Use the weight bench only as described in this manual.
4. The weight bench is intended for home use only. Do not use the weight bench in a commercial, rental, or institutional setting.
5. Keep the weight bench indoors, away from moisture and dust. Do not put the weight bench in a garage or covered patio, or near water.
6. Place the weight bench on a level surface, with enough clearance around the weight bench to mount, dismount, and use the weight bench.
7. Inspect and properly tighten all parts regularly. Replace any worn parts immediately.
8. Keep children under age 12 and pets away from the weight bench at all times.
9. Always wear athletic shoes for foot protection while using the weight bench.
10. The weight bench is designed to support a maximum user weight of 300 lbs. (136 kg), and a maximum total weight of 610 lbs. (277 kg). Do not place more than 310 lbs. (141 kg), including a barbell and weights, on the weight rests or the squat weight rests. Note: No barbell or weights are included.
11. Always exercise with a partner. When you are performing bench press exercises, your partner should stand behind you to catch the barbell if you cannot complete a repetition.
12. Always place the same amount of weight on both ends of the barbell. While adding or removing weights, always keep some weight on both ends of the barbell to prevent the barbell from tipping.
13. Before using the weight bench, make sure that the three knobs are fully engaged in adjustment holes.
14. Over exercising may result in serious injury or death. If you feel faint or if you experience pain while exercising, stop immediately and cool down.

BEFORE YOU BEGIN

Thank you for selecting the WEIDER PRO™ 450 L weight bench. The versatile 450 L weight bench is designed to develop every major muscle group of the body. Whether your goal is to develop a shapely figure, dramatic muscle size and strength, or a healthier cardiovascular system, the 450 L weight bench will help you to achieve the specific results you want.

For your benefit, read this manual carefully before using the weight bench. If you have questions after

reading this manual, please see the back cover of this manual. To help us assist you, note the product model number and serial number before contacting us. The model number and the location of the serial number decal are shown on the front cover of this manual.

Before reading further, please review the drawing below and familiarize yourself with the labeled parts.

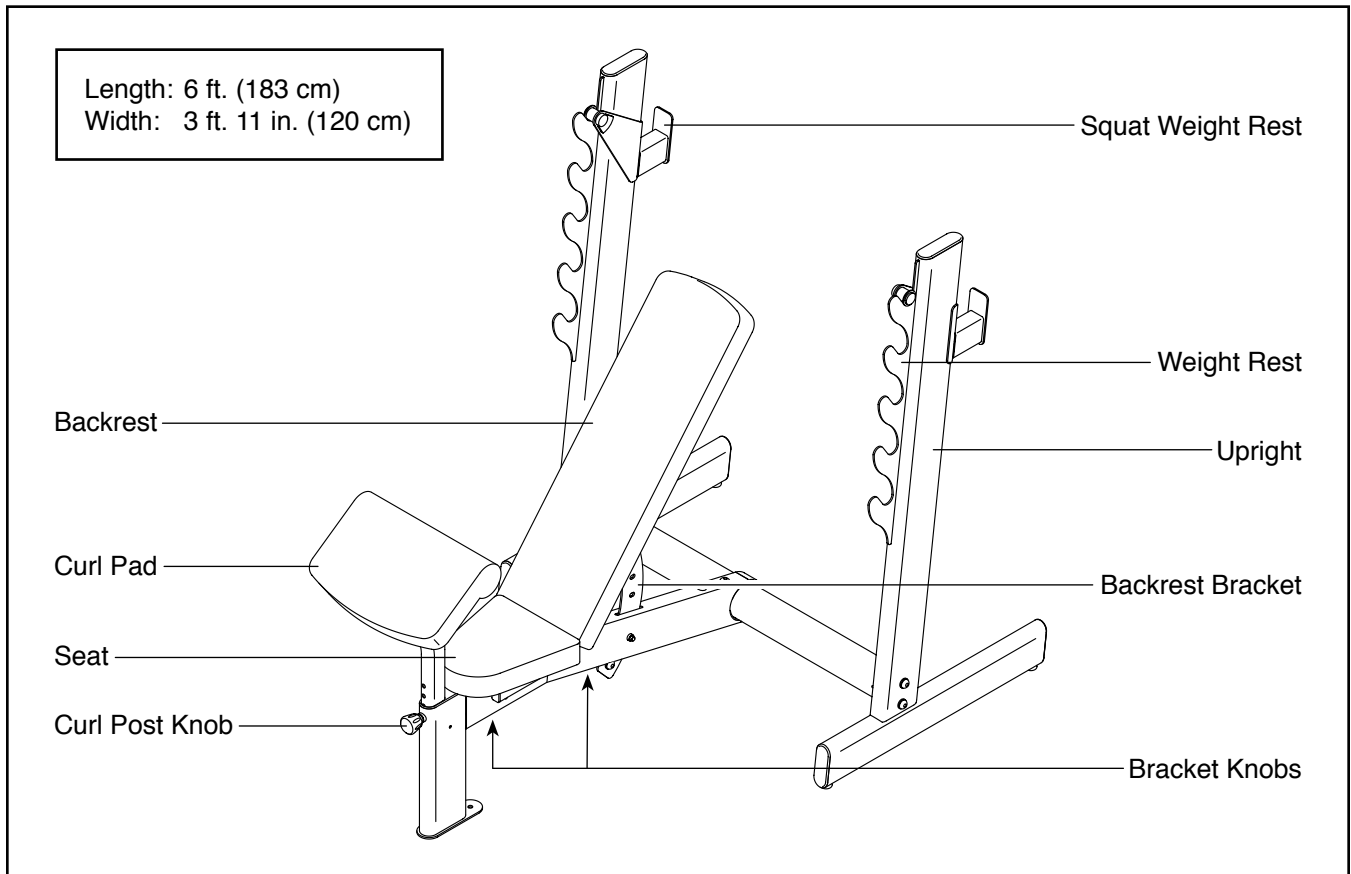

PART IDENTIFICATION CHART

Use the drawings below to identify the small parts needed for assembly. The number in parentheses below each drawing is the key number of the part, from the PART LIST near the end of this manual. The number following the key number is the quantity needed for assembly. **Note: If a part is not in the hardware kit, check to see if it has been preassembled. Extra parts may be included. If a part is missing, please call 1-877-992-5999.**

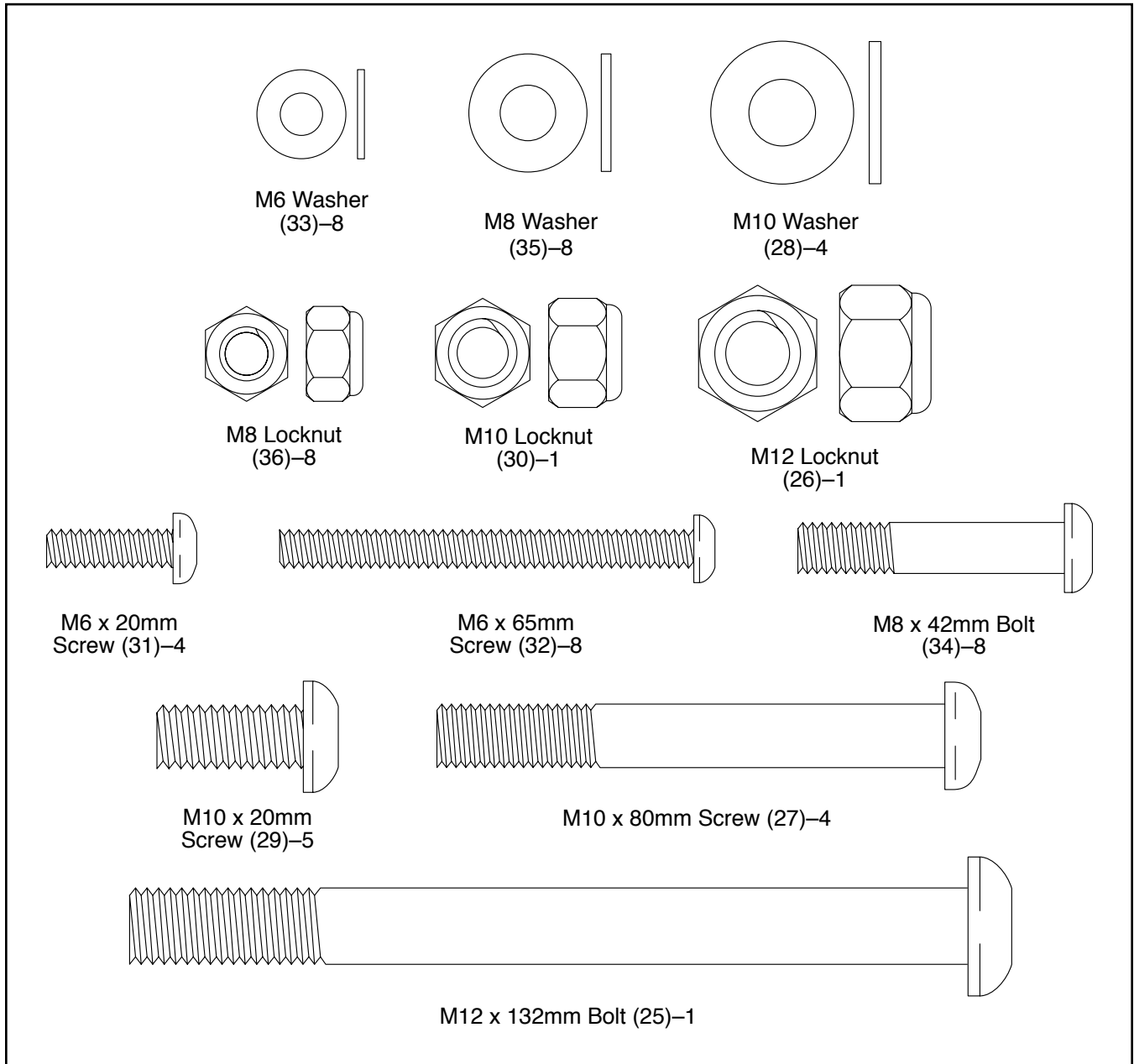

ASSEMBLY

- To watch an assembly video, go to <http://productvideo.co/assembly/sears/weider> or use your mobile phone or your smartphone to read the QR code at the right.



- Assembly requires two persons.
- Due to its weight and size, the weight bench should be assembled in the location where it will be used. Make sure that there is enough clearance to walk around the weight bench as you assemble it.
- Place all parts in a cleared area and remove the packing materials. Do not dispose of the packing materials until you finish all assembly steps.

- Left parts are marked “L” or “Left” and right parts are marked “R” or “Right.”
- To identify small parts, see page 5.
- In addition to the included tool(s), assembly requires the following tool(s):

one adjustable wrench



one Phillips screwdriver

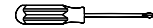

Assembly may be easier if you have a set of wrenches. To avoid damaging parts, do not use power tools.

1. Orient the Crossbar (2) as shown.

Attach the Crossbar (2) to one of the Uprights (3) with two M10 x 80mm Screws (27); **do not tighten the Screws yet.**

Attach the Crossbar (2) to the other Upright (3) in the same way.

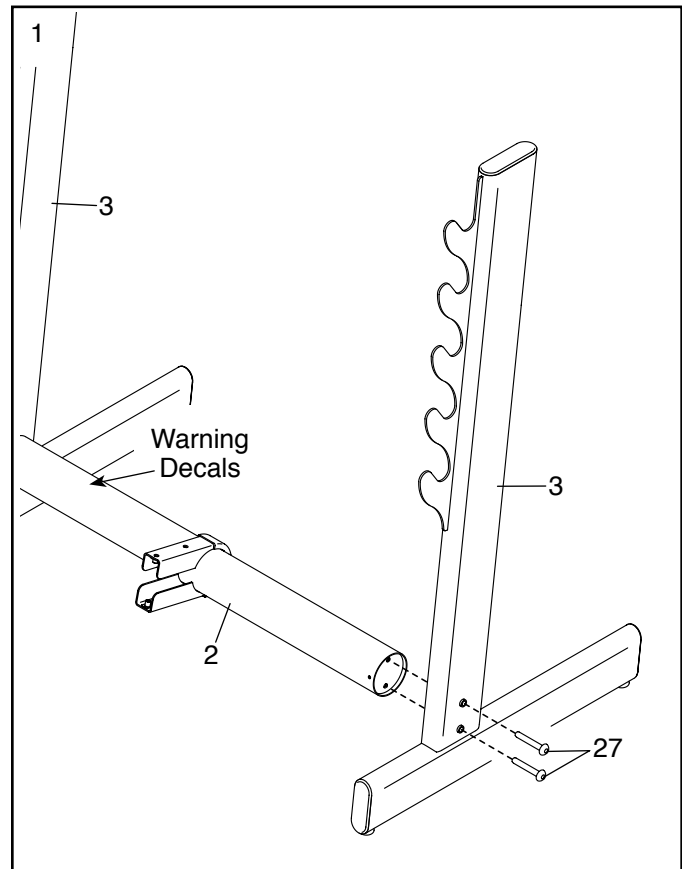

- Slide the end of the Frame (1) onto the Crossbar (2). Attach the Frame with four M10 x 20mm Screws (29) and four M10 Washers (28). **Start all four Screws, and then tighten them.**

See step 1. Tighten the four M10 x 80mm Screws (27).

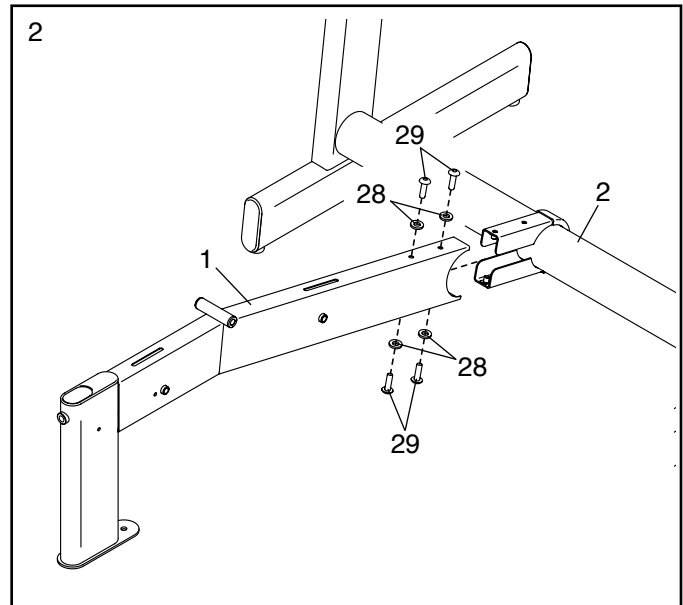

- Identify the Right Seat Frame (8), the Left Seat Frame (9), and the Seat Bracket (10). Orient the three parts as shown.

Attach the Left Seat Frame (9) to the Seat Bracket (10) with two M8 x 42mm Bolts (34), two M8 Washers (35), and two M8 Locknuts (36); **do not tighten the Bolts yet.**

Attach the Right Seat Frame (8) to the Seat Bracket (10) in the same way.

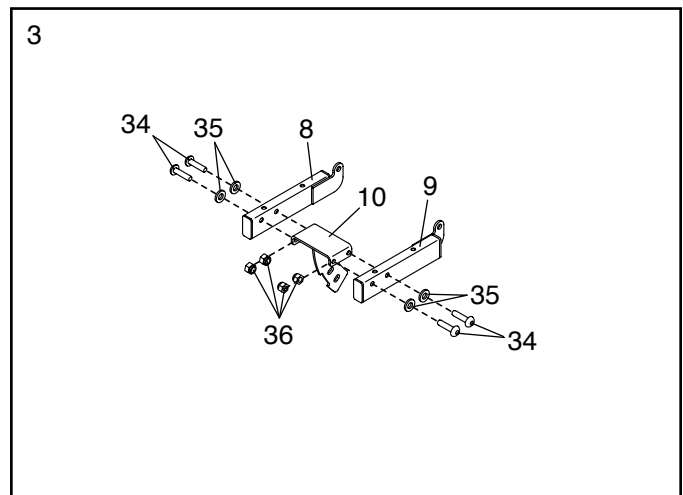

- Identify the Right Backrest Frame (5), the Left Backrest Frame (6), and the Backrest Bracket (7). Orient the three parts as shown.

Attach the Left Backrest Frame (6) to the Backrest Bracket (7) with two M8 x 42mm Bolts (34), two M8 Washers (35), and two M8 Locknuts (36); **do not tighten the Bolts yet.**

Attach the Right Backrest Frame (5) to the Backrest Bracket (7) in the same way.

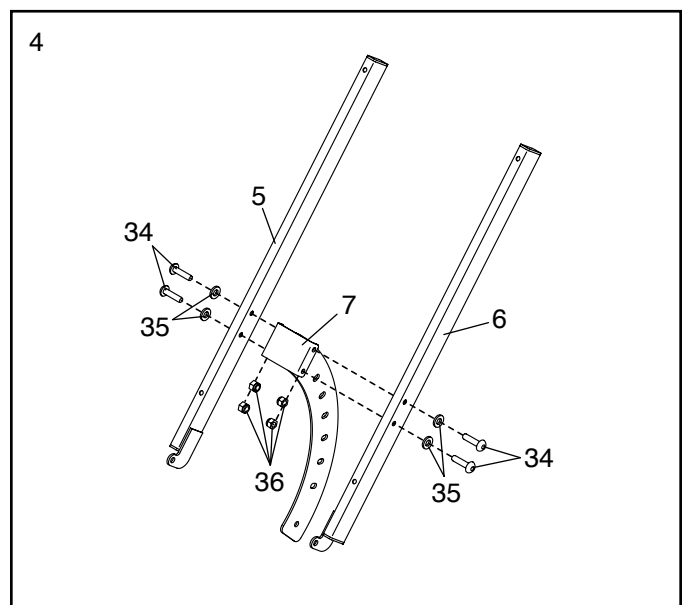

5. Insert the Seat Bracket (10) and the Backrest Bracket (7) into the two slots in the Frame (1) as shown.

Align the brackets on the Seat Frames (8, 9) and the brackets on the Backrest Frames (5, 6) with the welded tube on the Frame (1), as shown in the inset drawing.

Attach the Seat Frames (8, 9) and the Backrest Frames (5, 6) to the Frame (1) with an M12 x 132mm Bolt (25) and an M12 Locknut (26). **Do not overtighten the Locknut; the Seat Frames and the Backrest Frames must be able to pivot.**

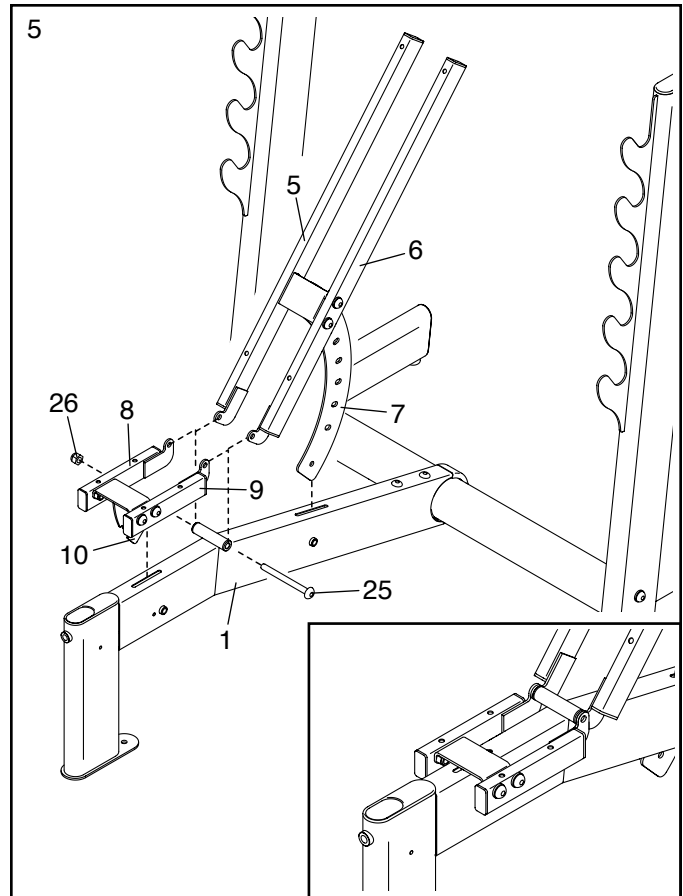

6. Tighten the Curl Post Knob (14) into the Frame (1) in the indicated location.

Next, tighten one of the Bracket Knobs (13) into the Frame (1) and into one of the adjustment holes in the Seat Bracket (10).

Tighten the other Bracket Knob (13) into the Frame (1) and into one of the adjustment holes in the Backrest Bracket (7).

Then, attach an M10 x 20mm Screw (29) and an M10 Locknut (30) to the lower end of the Backrest Bracket (7).

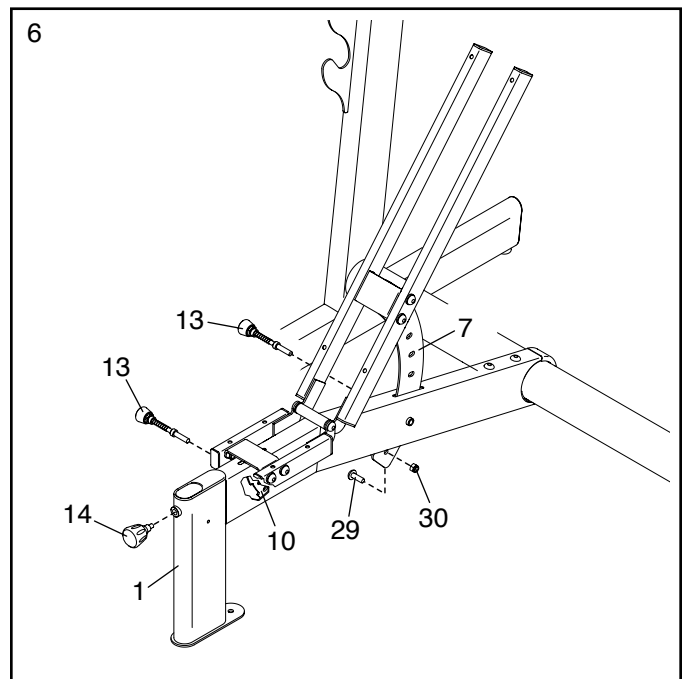

7. Attach the Seat (18) to the Seat Frames (8, 9) with four M6 x 65mm Screws (32) and four M6 Washers (33). **Start all four Screws, and then tighten them.**

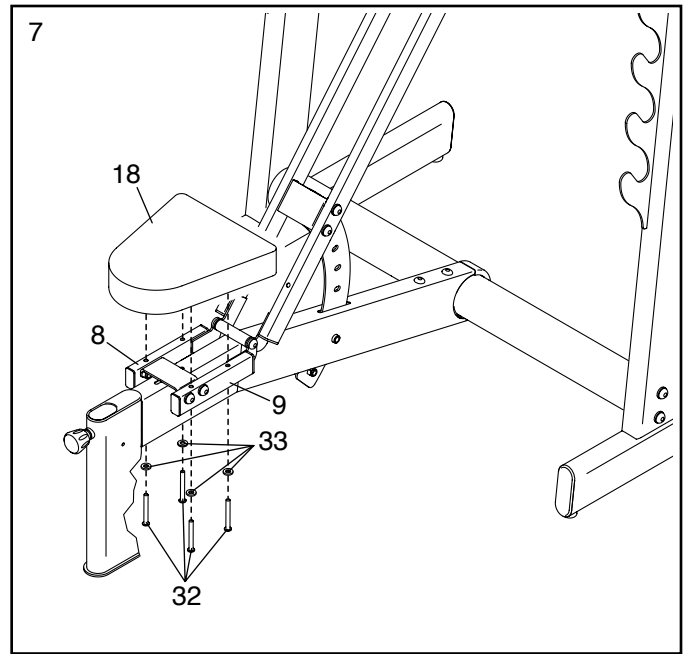

8. Attach the Backrest (19) to the Backrest Brackets (5, 6) with four M6 x 65mm Screws (32) and four M6 Washers (33). **Start all four Screws, and then tighten them.**

See steps 3 and 4. Tighten the eight M8 x 42mm Bolts (34).

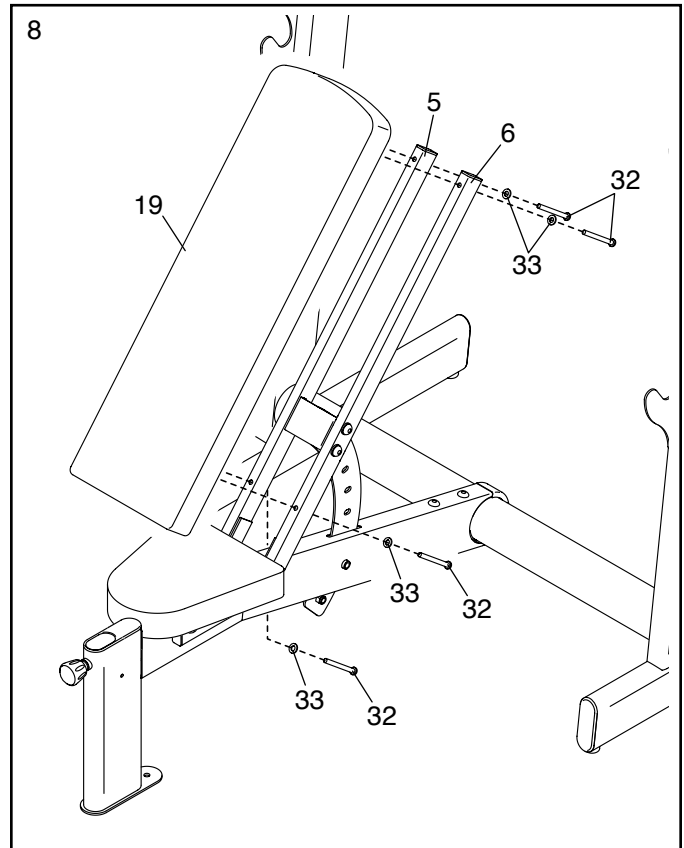

9. Attach the Right Squat Weight Rest (12) and the Left Squat Weight Rest (11) to the Uprights (3) as shown.

Make sure that both Squat Weight Rests (11, 12) are at the same height.

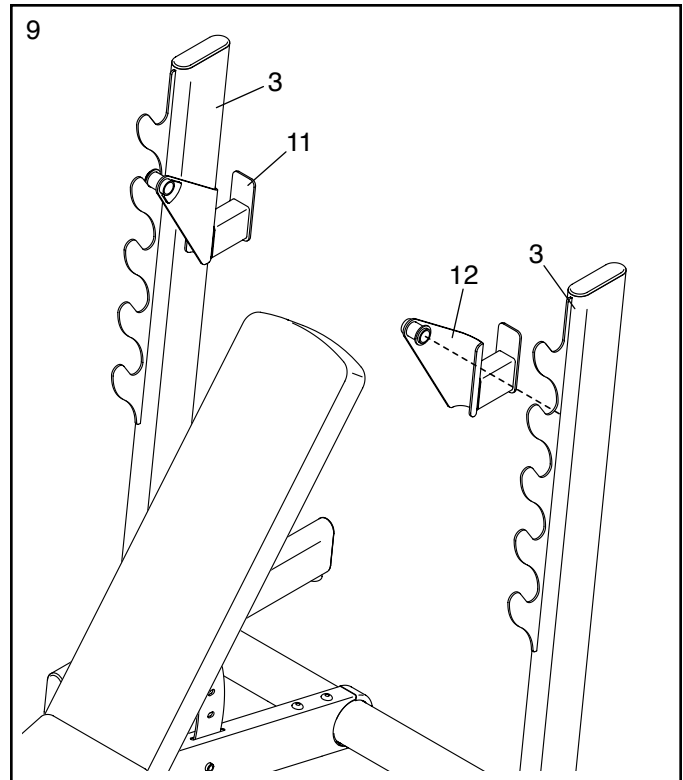

10. Attach the Curl Pad (17) to the Curl Post (4) with four M6 x 20mm Screws (31). **Start all four Screws, and then tighten them.**

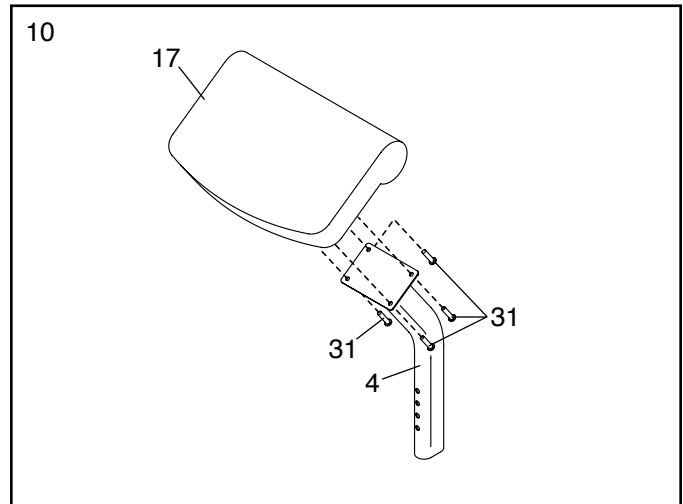

11. **Make sure that all parts are properly tightened before the weight bench is used.** Note: Extra parts may be included. The use of all remaining parts will be explained in ADJUSTMENT, beginning on page 11.

ADJUSTMENT

The steps below explain how the weight bench can be adjusted. Make sure that all parts are properly tightened each time the weight bench is used. Replace any worn parts immediately. The weight bench can be cleaned with a damp cloth and a mild, non-abrasive detergent; **do not use solvents to clean the weight bench.**

ADJUSTING THE BACKREST AND THE SEAT

To adjust the angle of the Backrest (19), pull the indicated Bracket Knob (13), raise or lower the Backrest, and then release the Bracket Knob into one of the adjustment holes in the Backrest Bracket (7). **Move the Backrest upward or downward to make sure that the Backrest Knob is engaged in one of the adjustment holes.**

Adjust the angle of the Seat (18) in the same way.

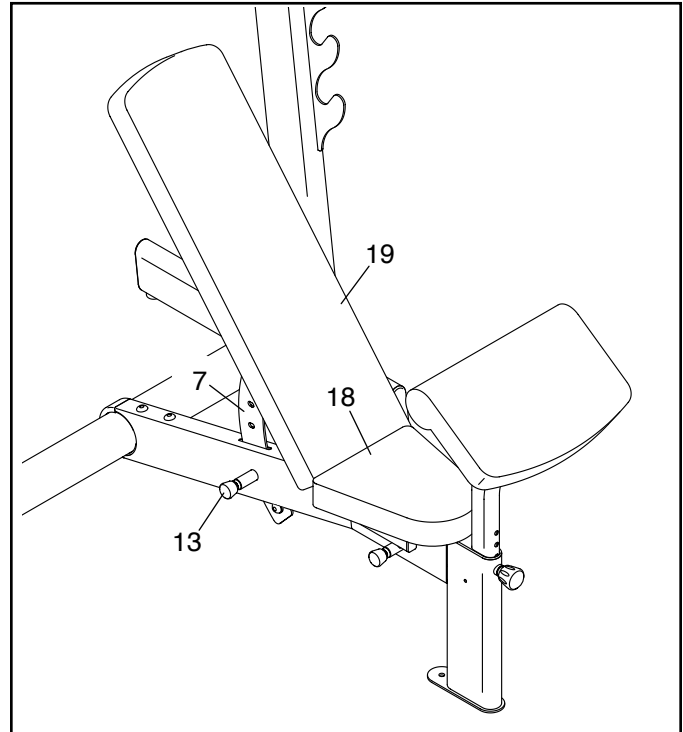

USING THE CURL PAD

To use the Curl Pad (17), pull the Curl Post Knob (14), insert the Curl Post (4) into the Frame (1), and then release the Curl Post Knob into one of the adjustment holes in the Curl Post. **Move the Curl Post upward or downward to make sure that the Curl Post Knob is engaged in one of the adjustment holes.**

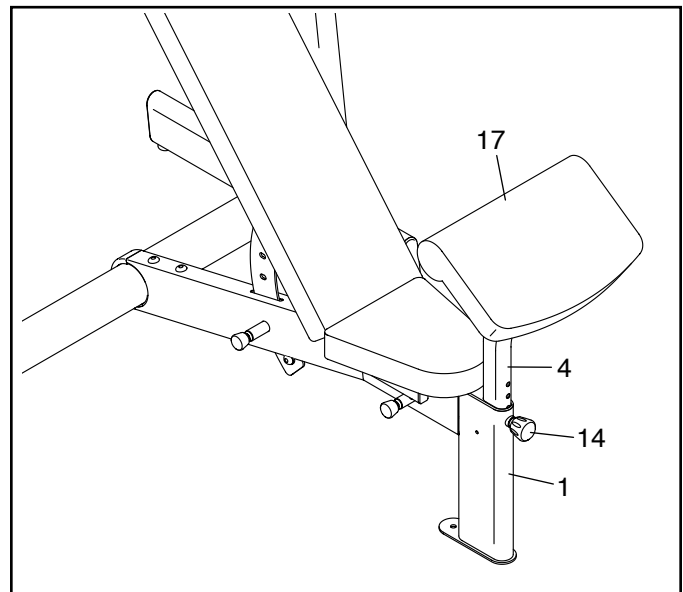

USING THE SQUAT WEIGHT RESTS

To perform squat exercises, attach the Squat Weight Rests (11, 12) to the Uprights (3) at the desired height. **Make sure that both Squat Weight Rests (11, 12) are at the same height.**

⚠ WARNING: Do not place more than 310 lbs. (141 kg) of weight (not included) on the Squat Weight Rests (11, 12).

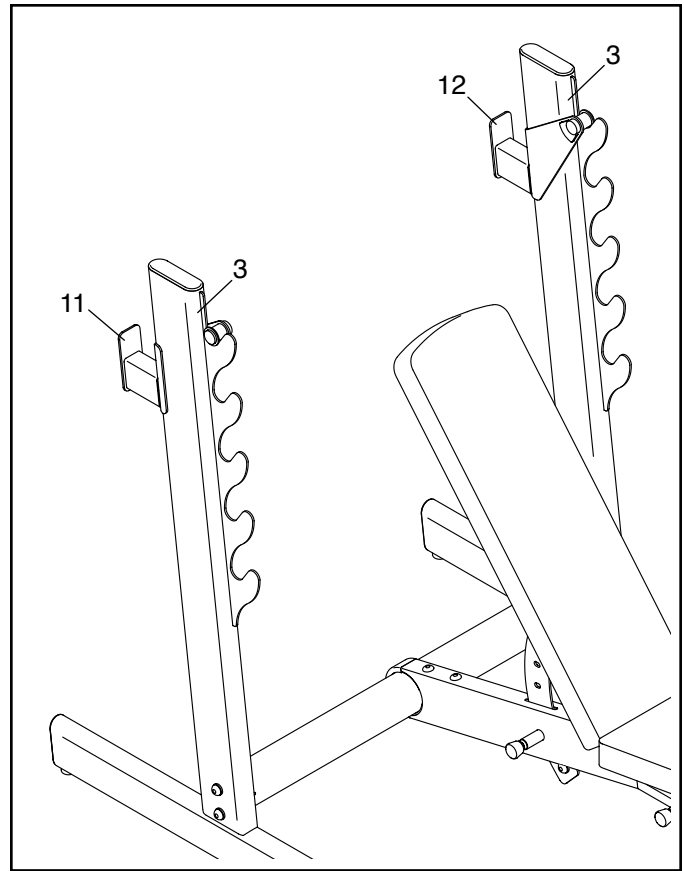

EXERCISE GUIDELINES

FOUR TYPES OF STRENGTH WORKOUTS

Note: A “repetition” is one complete cycle of an exercise, such as one sit-up. A “set” is a series of repetitions.

Muscle Building—Work your muscles near their maximum capacity and progressively increase the intensity of your exercise. Adjust the intensity level of an individual exercise as follows:

- Change the amount of resistance used.
- Change the number of repetitions or sets performed.

Use your own judgment to determine the amount of resistance that is right for you. Begin with 3 sets of 8 repetitions for each exercise you perform. Rest for 3 minutes after each set. When you can complete 3 sets of 12 repetitions without difficulty, increase the amount of resistance.

Toning—Tone your muscles by working them to a moderate percentage of their capacity. Select a moderate amount of resistance and increase the number of repetitions in each set. Complete as many sets of 15 to 20 repetitions as possible without discomfort. Rest for 1 minute after each set. Work your muscles by completing more sets rather than by using high amounts of resistance.

Weight Loss—To lose weight, use a low amount of resistance and increase the number of repetitions in each set. Exercise for 20 to 30 minutes, resting for a maximum of 30 seconds between sets.

Cross Training—Combine strength training and aerobic exercise by following this type of program:

- Strength training workouts on Monday, Wednesday, and Friday.
- 20 to 30 minutes of aerobic exercise on Tuesday and Thursday.
- One full day of rest each week to give your body time to regenerate.

WORKOUT GUIDELINES

Familiarize yourself with the equipment and learn the proper form for each exercise. Use your own judgment to determine the appropriate length of time for each

workout, and the numbers of repetitions and sets to complete. Progress at your own pace and be sensitive to your body’s signals. Follow each workout with at least one day of rest.

Warming Up—Start with 5 to 10 minutes of stretching and light exercise. A warm-up increases your body temperature, heart rate, and circulation in preparation for exercise.

Working Out—Include 6 to 10 different exercises in each workout. Select exercises for every major muscle group, emphasizing areas that you want to develop. To give balance and variety to your workouts, vary the exercises from workout to workout.

Cooling Down—Finish with 5 to 10 minutes of stretching. Stretching increases the flexibility of your muscles and helps to prevent post-exercise problems.

EXERCISE FORM

Move through the full range of motion for each exercise and move only the appropriate parts of the body. Perform the repetitions in each set smoothly and without pausing. The exertion stage of each repetition should last about half as long as the return stage. Exhale during the exertion stage of each repetition and inhale during the return stroke. Never hold your breath.

Rest for a short period of time after each set:

- Muscle Building—Rest for three minutes after each set.
- Toning—Rest for one minute after each set.
- Weight Loss—Rest for 30 seconds after each set.

STAYING MOTIVATED

For motivation, keep a record of each workout. Write the date, the exercises performed, the resistance used, and the numbers of sets and repetitions completed. Record your weight and key body measurements once a month. To achieve good results, make exercise a regular and enjoyable part of your life.

PART LIST

Model No. 831.15948.0 R0812A

Key No.	Qty.	Description	Key No.	Qty.	Description
1	1	Frame	21	4	Small Oval Cap
2	1	Crossbar	22	8	Rectangular Cap
3	2	Upright	23	1	Crossbar Cover
4	1	Curl Post	24	5	M4 x 19mm Screw
5	1	Right Backrest Frame	25	1	M12 x 132mm Bolt
6	1	Left Backrest Frame	26	1	M12 Locknut
7	1	Backrest Bracket	27	4	M10 x 80mm Screw
8	1	Right Seat Frame	28	4	M10 Washer
9	1	Left Seat Frame	29	5	M10 x 20mm Screw
10	1	Seat Bracket	30	1	M10 Locknut
11	1	Left Squat Weight Rest	31	4	M6 x 20mm Screw
12	1	Right Squat Weight Rest	32	8	M6 x 65mm Screw
13	2	Bracket Knob	33	8	M6 Washer
14	1	Curl Post Knob	34	8	M8 x 42mm Bolt
15	2	Frame Bushing	35	8	M8 Washer
16	1	Frame Sleeve	36	8	M8 Locknut
17	1	Curl Pad	37	2	Large Oval Cap
18	1	Seat	38	4	Round Cap
19	1	Backrest	*	–	Grease Packet
20	4	Foot	*	–	User's Manual

Note: Specifications are subject to change without notice. For information about ordering replacement parts, see the back cover of this manual. **If a part is missing, call 1-877-992-5999.** *These parts are not illustrated.

EXPLODED DRAWING

Model No. 831.15948.0 R0812A

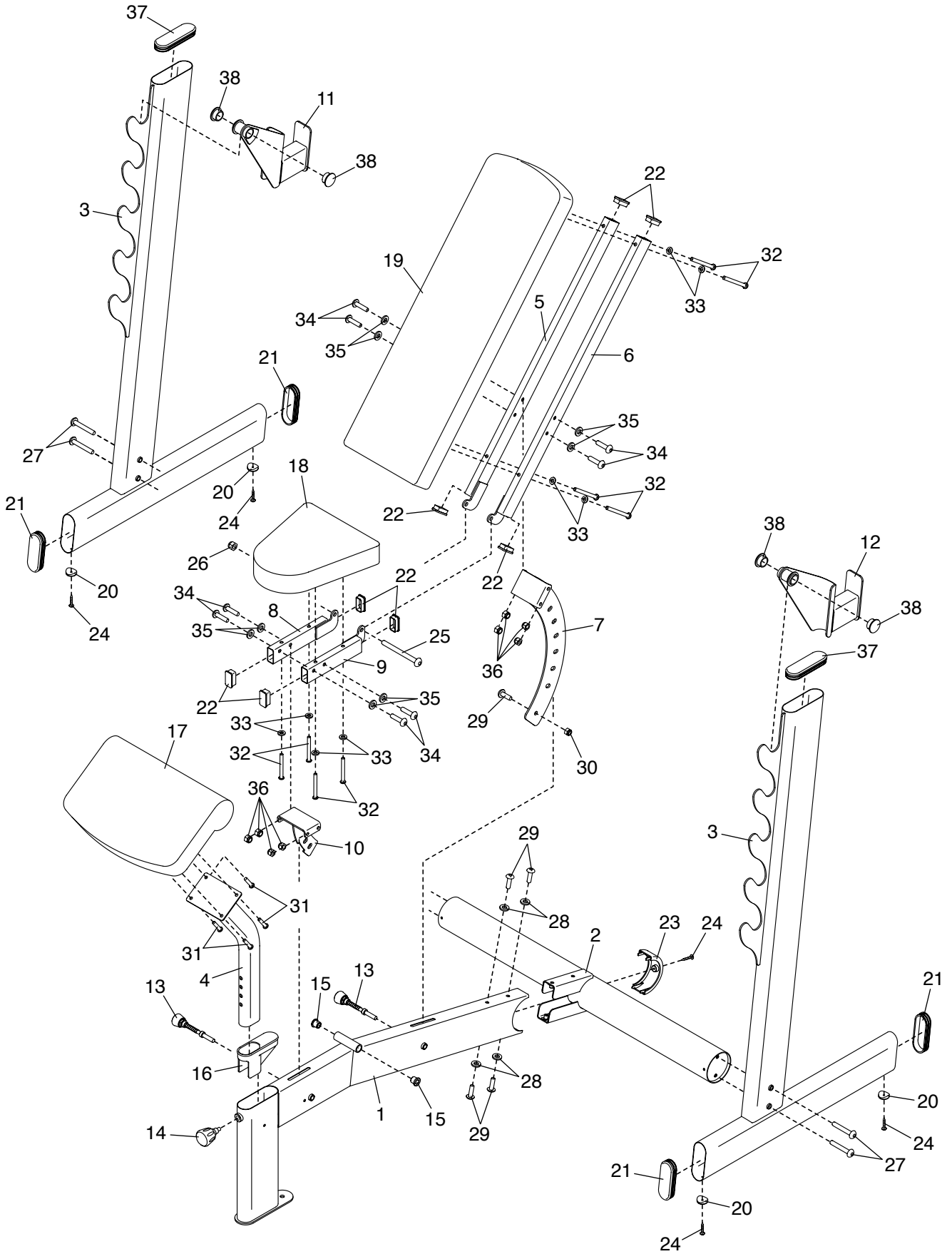

Get it fixed, at your home or ours!

Your Home

For repair—in **your home**—of **all** major brand appliances, lawn and garden equipment, or heating and cooling systems, **no matter who made it, no matter who sold it!**

For the replacement parts, accessories, and user's manuals that you need to do-it-yourself.

For Sears professional installation of home appliances and items like garage door openers and water heaters.

1-800-4-MY-HOME® (1-800-469-4663)

Call anytime, day or night (U.S.A. and Canada)

www.sears.com

www.sears.ca

Our Home

For repair of carry-in items like vacuums, lawn equipment, and electronics, call or go on-line for the location of your nearest **Sears Parts & Repair Center.**

1-800-488-1222 Call anytime, day or night (U.S.A. only)

www.sears.com

To purchase a protection agreement (U.S.A.) or maintenance agreement (Canada) on a product serviced by Sears:

1-800-827-6655 (U.S.A.)

1-800-361-6665 (Canada)

Para pedir servicio de reparación a domicilio, y para ordenar piezas:

1-888-SU-HOGAR® (1-888-784-6427)



® Registered Trademark / ™ Trademark / ™ Service Mark of Sears Brands, LLC
® Marca Registrada / ™ Marca de Fábrica / ™ Marca de Servicio de Sears Brands, LLC

90 DAY FULL WARRANTY

If this Sears Weight Bench Exerciser fails due to a defect in material or workmanship within 90 days of the date of purchase, call 1-800-4-MY-HOME® (1-800-469-4663) to arrange for free repair (or replacement if repair proves impossible).

This warranty does not apply when the Weight Bench Exerciser is used commercially or for rental purposes. This warranty gives you specific legal rights, and you may also have other rights which vary from state to state.

Sears, Roebuck and Co., Hoffman Estates, IL 60179