

341
WB-340
CLASSIC

weider®

Assembly Instructions

WEIDER HEALTH AND FITNESS
21100 Erwin Street, Woodland Hills, California, U.S.A. 91367

Diagram No.	Part Name	No. Required	Part Number
1	Upright	1	CA03-0203
2	Base Frame	1	CA03-0103
3	Main Frame	1	CA03-0105
4	Backrest	1	CA03-0304
5	Seat	1	CA03-0305
6	Leg Curl	1	CA03-0106
7	Adjustable Uprights	2	CA03-0204
8	Backrest Adjustment Bar	1	CA03-6006
9	Foam Pad	4	CA03-0401
10	Pad Bar	2	CA03-6007
11	Seat Adjustment "T"	1	CA03-6008
12	Backrest Angle Iron	2	CA03-6009
13	Seat Angle Iron	2	CA03-6010
14	U-Brackets	2	CA03-6011
A	5/16"-20 x 2 1/2" Hex Head Bolt	5	HH-5070
B	5/16" Lock Nut	5	HH-5021
C	3/8"-16 x 3" Hex Head Bolt	3	HH-5059
D	3/8"-16 Lock Nut	1	HH-5013
E	1 1/4"-20 x 3/4" Machine Screw	1	HH-5032
F	1/4"-20 Lock Nut	1	HH-5011
G	Locking Pin (Small)	2	WW-7020
H	Locking Pin (Large)	1	WW-7021
J	2" Square Plastic Cap	7	AA-8002
K	1" Round Plastic Cap SM.	1	AA-8005
M	Eyelet Pin	1	WW-7005
N	1/4"-20 x 1/2" Machine Screw	8	HH-5025
P	3/4" Round Plastic Cap	4	AA-8005
Q	1" Round Plastic Cap	1	AA-8070
	Hardware Bag	1	CA03-5752
	Instruction Manual	1	CIN112687

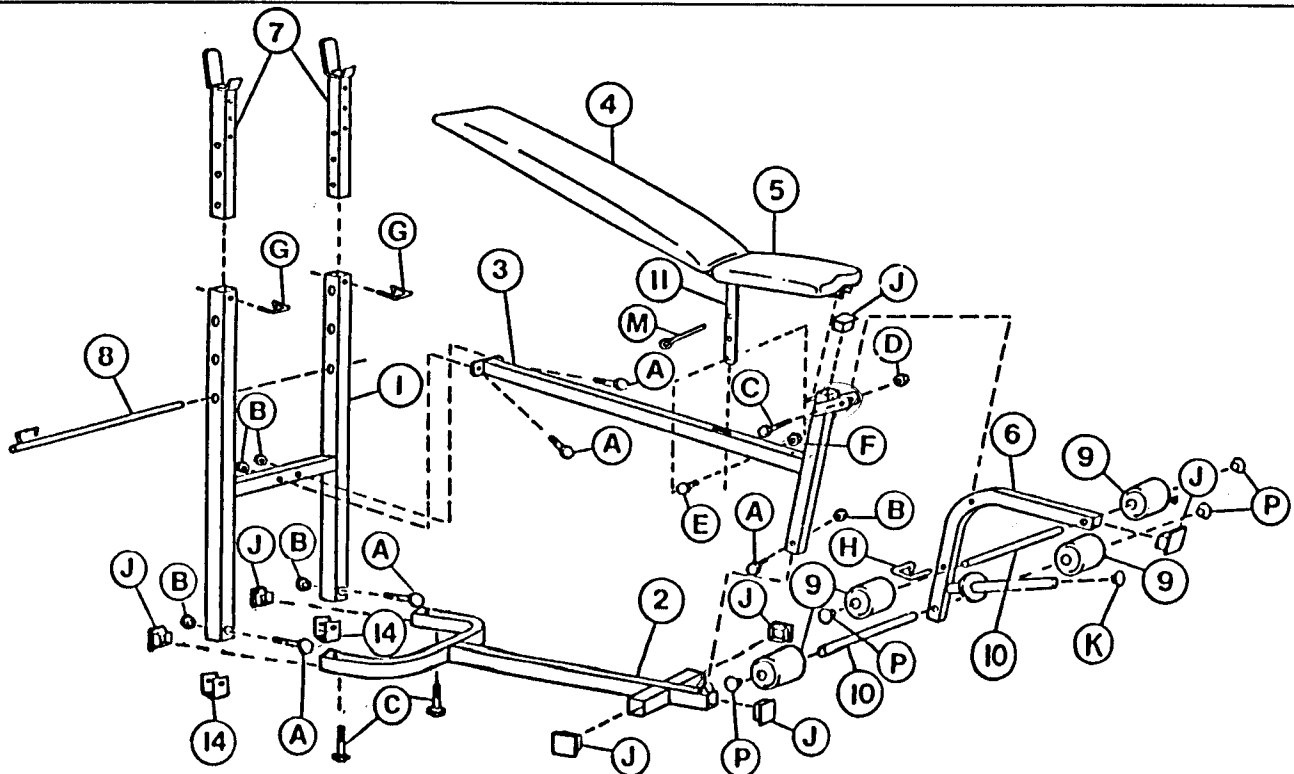

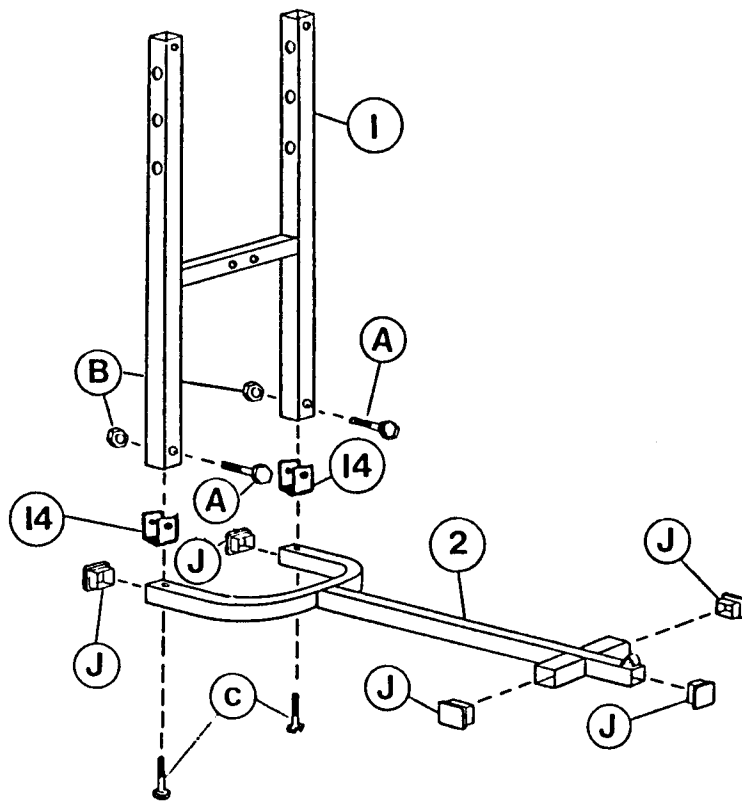

Step 1

Lay out BASE FRAME (2) and insert HEX HEAD BOLTS (C) through holes in rear of Frame. U-BRACKETS (14) are then screwed onto BOLTS (C), but not completely tightened. Holes in U-Brackets should be facing the sides of the bench as shown in the diagram. Place UPRIGHT (1) on U-BRACKETS (14) and insert HEX BOLTS (A) through each hole at base of Upright making sure bolt passes through U-Bracket holes. Secure bolts with LOCK NUT (B). Tighten all bolts. Insert five SQUARE PLASTIC CAPS (J) into Base Frame.

Step 2

Set MAIN FRAME (3) in position with flat plate against Upright lining up holes. Attach Main Frame to Upright with two HEX HEAD BOLTS (A) and LOCK NUTS (B). Secure Main Frame to Base with HEX HEAD BOLT (A) and LOCK NUT (B). Insert SQUARE PLASTIC CAP (J) in Frame top as shown.

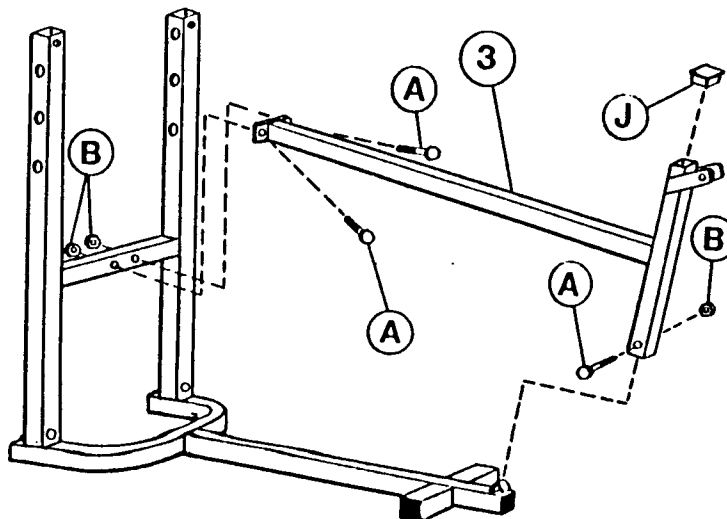

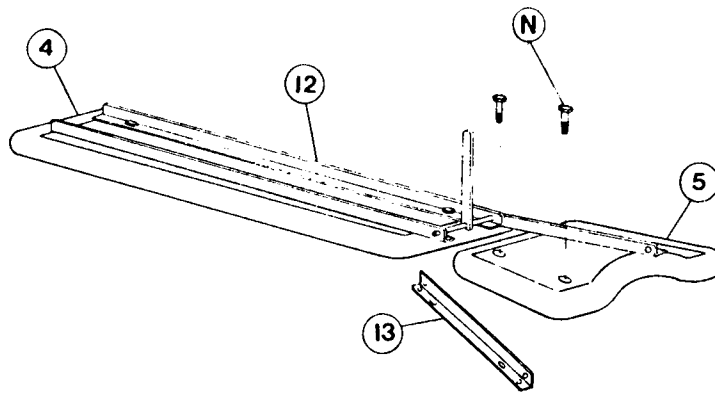

Step 3

Turn BACKREST (4) and SEAT (5) assembly over and remove two MACHINE SCREWS (N) to free SEAT ANGLE IRON (13).

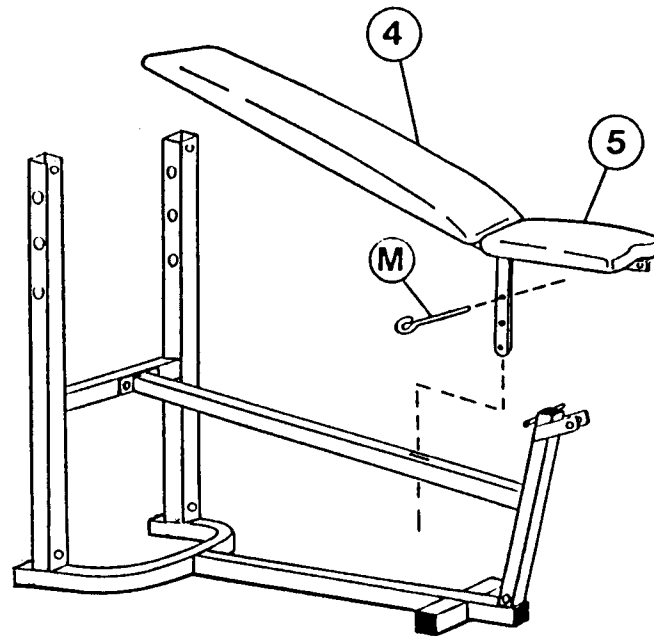

Step 4

Turn BACKREST (4) and SEAT (5) assembly right side up and lower onto Main Frame. Align SEAT ADJUSTMENT "T" (11) over slot in Main Frame and slide secured Seat Angle Iron over one side of pivot rod. Use EYELET PIN (M) to adjust Backrest and Seat height.

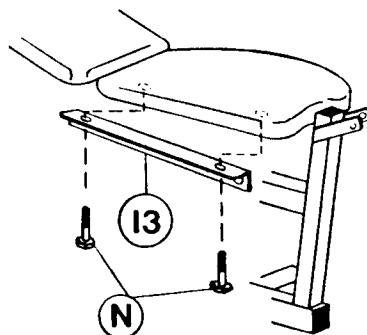

Step 5

Slide SEAT ANGLE IRON (13) onto SEAT ADJUSTMENT "T" rod. Align holes of Seat Angle Iron with seat holes and replace MACHINE SCREWS (N).

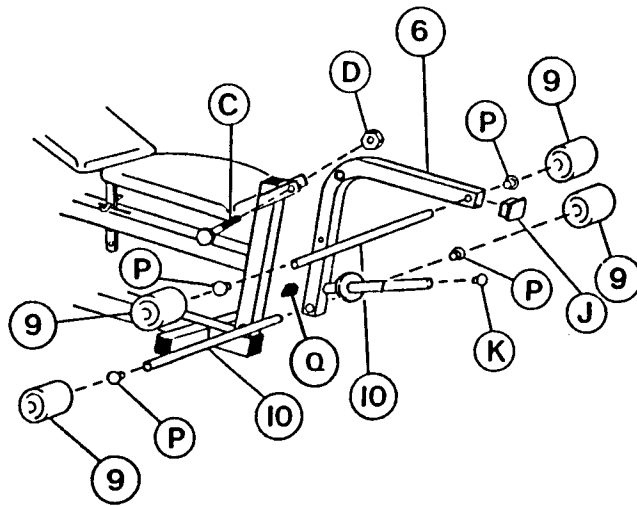

Step 6

Place LEG CURL (6) between Leg Curl Brackets on Main Frame and secure with HEX HEAD BOLT (C) and LOCK NUT (D). Slide PAD BAR (10) through lower hole in LEG CURL (6) until equal amounts of bar are on both sides. Insert ROUND PLASTIC CAP (P) into both ends of PAD BAR (10). Slide FOAM PAD (9) onto both ends of Pad Bar. Follow the same procedure with upper pad bar until all pads are in place. Insert SQUARE PLASTIC CAPS (J) into Leg Curl. Insert ROUND PLASTIC CAPS (K and Q) into end of weight holder on Leg Curl.

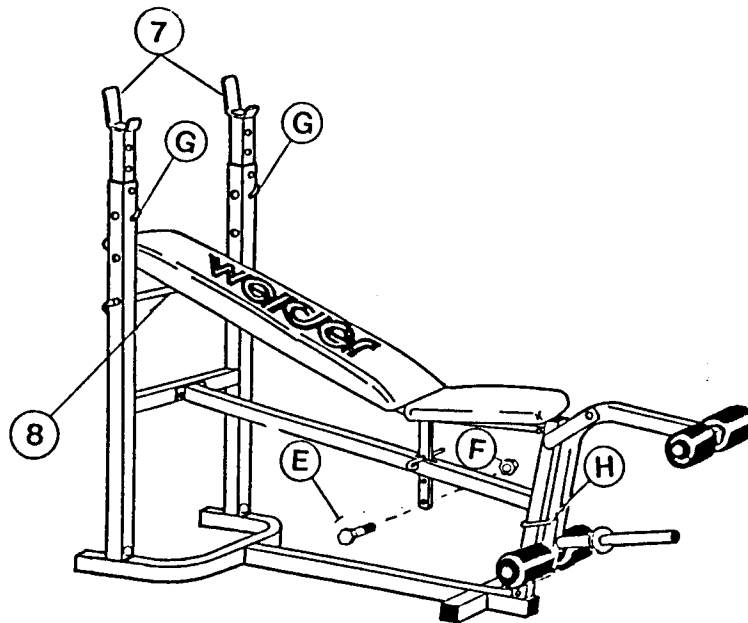

Step 7

Place ADJUSTABLE UPRIGHTS (7) into Uprights and use LOCKING PINS (G) to adjust their height. BACKREST ADJUSTMENT BAR (8) is used to raise or lower the Backrest. MACHINE SCREW (E) and LOCK NUT (F) are placed in lower hole of Seat Adjustment "T" to prevent the "T" from coming out of the slot. The Leg Curl is locked to the Frame by using the LOCKING PIN (H).

SUPPLEMENTAL PARTS LIST

PLEASE USE THESE PARTS NUMBERS WHEN ORDERING PARTS FOR
YOUR B-341 HERMANS BENCH.

WB-341

PARTS LIST

6-20-88

DIAGRAM NO.	PART NAME	NO. REQ'D	ORDER NO.
1	Upright	1	CA03-0221
2	Base Frame	1	CA03-0141
3	Main Frame	1	CA03-0142
4	Backrest	1	CA03-0329
5	Seat	1	CA03-0330
6	Leg Curl	1	CA03-0143
7	Adjustable Uprights	2	CA03-0222
8	Backrest Adjustment Bar	1	CA03-6006
9	Foam Pad	4	CA03-0401
10	Pad Bar	2	CA03-6085
11	Seat Adjustment "T"	1	CA03-6086
12	Backrest Angle Iron	2	CA03-6087
13	Seat Angle Iron	2	CA03-6088
14	U-Brackets	2	CA03-6011
A	5/16"-20 x 2 1/2" Hex Head	5	HH-5070
A-1	3/8"-20 x 2 3/4" Hex Head Bolt	2	
B	5/16" Lock Nut	5	HH-5021
C	3/8"-16 x 3" Hex Head Bolt	1	HH-5059
D	3/8"-16 Lock Nut	1	HH-5013
E	1/4"-20 x 3/4" Hex Head Bolt	1	HH-5032
F	1/4"-20 Lock Nut	1	HH-5011
G	Locking Pin (Small)	2	WW-7020
H	Locking Pin (Large)	1	WW-7021
J	2" Square Plastic Cap	8	AA-8002
K	1" Round Plastic Cap	1	AA-8005
M	Eyelet Pin	1	WW-7005
N	1/4"-20 x 1/2" Hex Head Bolt	8	HH-5025
P	3/4" Round Plastic Cap	4	AA-8004
	Hardware Bag	1	CA03-5752
	Instruction Manual	1	CIN112687

INVENTORY B341 (HERMAN'S)

Department _____

Priced by _____

Sheet No. _____

Location _____

Extended by _____

Called by _____

Examined by AUG 19 1986

Entered by _____

Form 3477 Taylor Print Shop, Olney, Illinois

ITEM NO	DESCRIPTION	√	QUANTITY	UNIT	PRICE	UNIT	Tot.
A03-5752	HARDWARE BAG		1		2.98		
HH-5070	5/16"-20 x 2 3/4" HEX HEAD BOLT	A	7		.08		
HH-5021	5/16"-20 LOCK NUT	B	5		.04		
HH-5059	3/8"-16 x 3" HEX HEAD BOLT	C	1		.09		
HH-5013	3/8"-16 LOCK NUT	D	1		.04		
HH-5032	1/4"-20 x 3/4" HEX HEAD BOLT	E	1		.06		
HH-5011	1/4"-20 LOCK NUT	F	1		.02		
HH-5025	1/4"-20 x 1/2" HEX HEAD BOLT	N	8		.04		
AA-8002	2" SQUARE PLASTIC CAP	J	8		.09		
AA-8004	3/4" ROUND PLASTIC CAP	P	4		.04		
AA-8005	1" ROUND PLASTIC CAP	K	1		.04		
WW-7005	EYELET PIN 5/16" DWIRE 3 1/2" L	M	1		.15		
WW-7020	LOCKING PIN (SMALL)	G	2		.19		
WW-7021	LOCKING PIN (LARGE)	H	1		.24		

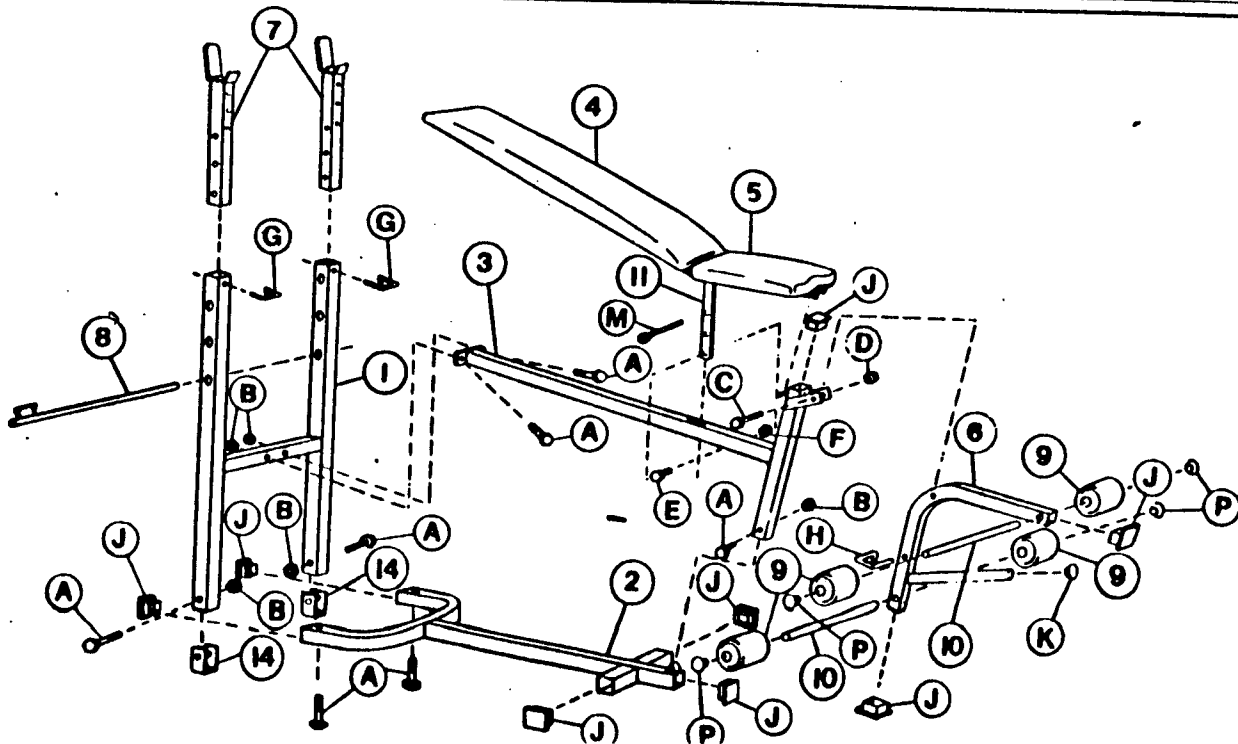

INVENTORY B341 (HERMAN'S)

19__

Department _____

Priced by _____

Sheet No. _____

Location _____

Extended by _____

Called by _____

Examined by AUG 19 1988

Entered by _____

Form 3477

Taylor Print Shop, Olney, Illinois

ITEM NO	DESCRIPTION	✓	QUANTITY	UNIT	PRICE	UNIT		Total
A18-0221	UPRIGHT	1	1		4.25			
A18-0141	BASE FRAME	2	1		5.10			
A18-0142	MAIN FRAME	3	1		5.00			
A18-0329	BACKREST	4	1		3.01			
A18-0330	SEAT	5	1		2.75			
A18-0143	LEG CURL	6	1		3.00			
A18-0222	ADJUSTABLE UPRIGHT	7	2		2.40			
A03-6006	BACKREST ADJ BAR	8	1		1.20			
A03-0401	FORM PAD	9	4		.65			
A18-6085	PAD BAR	10	2		.35			
A18-6086	SEAT ADJ T	11	1		.75			
A18-6087	LONG ANGLE IRON	12	2		.50			
A18-6088	SHORT ANGLE IRON	13	2		.30			
A03-6011	U-BRACKET	14	2		.15			
NN-1001	INSTRUCTION MANUAL		1		.30			
NN-1002	SUPPLEMENTAL SHEET		1		.0			



