

# WEIDER® 340 LC

Model No. WEEVBE24910.0

Serial No. \_\_\_\_\_

Write the serial number in the space above for reference.

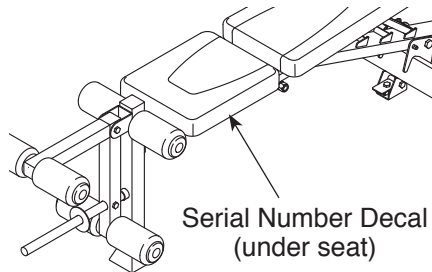

## USER'S MANUAL

### QUESTIONS?

If you have questions, or if there are missing parts, please contact us:

**UNITED KINGDOM**

Call: 08457 089 009

From Ireland: 053 92 36102

Website: [www.iconsupport.eu](http://www.iconsupport.eu)

E-mail: [csuk@iconeurope.com](mailto:csuk@iconeurope.com)

**Write:**

ICON Health & Fitness, Ltd.

c/o HI Group PLC

Express Way

CASTLEFORD

WF10 5QJ

UNITED KINGDOM

**AUSTRALIA**

Call: 1800 993 770

E-mail: [australiacc@iconfitness.com](mailto:australiacc@iconfitness.com)

**Write:**

ICON Health & Fitness

PO Box 635

WINSTON HILLS NSW 2153

AUSTRALIA

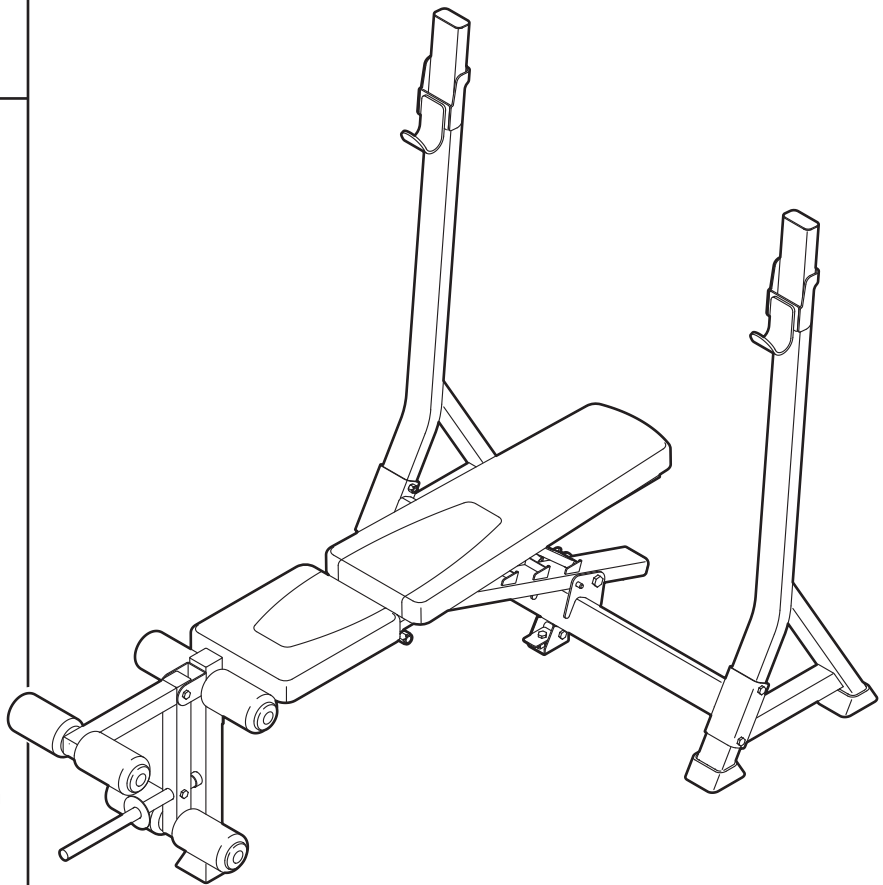

### ⚠ CAUTION

Read all precautions and instructions in this manual before using this equipment. Keep this manual for future reference.

# TABLE OF CONTENTS

WARNING DECAL PLACEMENT .....	2
IMPORTANT PRECAUTIONS .....	3
BEFORE YOU BEGIN .....	4
PART IDENTIFICATION CHART .....	5
ASSEMBLY .....	6
ADJUSTMENT .....	11
EXERCISE GUIDELINES .....	13
PART LIST .....	14
EXPLODED DRAWING .....	15
ORDERING REPLACEMENT PARTS .....	Back Cover

## WARNING DECAL PLACEMENT

This drawing shows the location(s) of the warning decal(s). **If a decal is missing or illegible, see the front cover of this manual and request a free replacement decal. Apply the decal in the location shown.** Note: The decal(s) may not be shown at actual size.

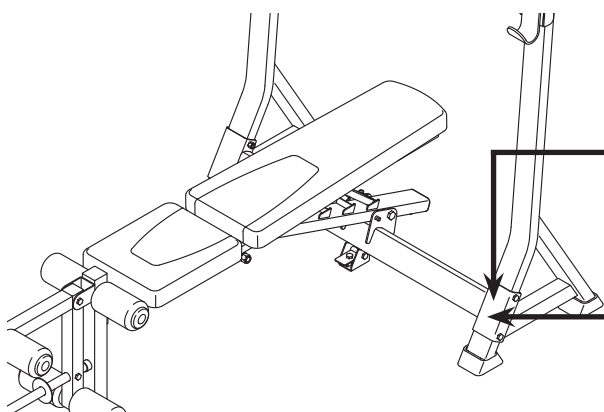

**⚠ WARNING**

User Weight: Max 300 LBS  
Weight Crutch: Max 210 LBS  
Leg Developer: Max 130 LBS  
Weight Carriage: Max 130 LBS  
Chest Fly Per Arm: Max 40 LBS

Product may not offer all listed exercises.

**⚠ WARNING**

- Misuse of this machine may result in serious injury.
- Read user's manual prior to use and follow all warnings and instructions.
- Do not allow children on or around machine.
- Keep body, clothing, and hair free and clear of all moving parts.
- Replace label if damaged, illegible, or removed.



# IMPORTANT PRECAUTIONS

**⚠️ WARNING:** To reduce the risk of serious injury, read all important precautions and instructions in this manual and all warnings on your weight bench before using your weight bench. ICON assumes no responsibility for personal injury or property damage sustained by or through the use of this product.

1. Before beginning any exercise program, consult your physician. This is especially important for persons over age 35 or persons with pre-existing health problems.
2. Read all instructions in this manual and all warnings on the weight bench before using the weight bench.
3. It is the responsibility of the owner to ensure that all users of the weight bench are adequately informed of all precautions.
4. The weight bench is intended for home use only. Do not use the weight bench in a commercial, rental, or institutional setting.
5. Keep the weight bench indoors, away from moisture and dust. Place the weight bench on a level surface, with a mat beneath it to protect the floor or carpet. Make sure that there is enough clearance around the weight bench to mount, dismount, and use the weight bench.
6. Inspect and properly tighten all parts regularly. Replace any worn parts immediately.
7. The weight bench is designed to support a maximum user weight of 300 lbs. (136 kg) and a maximum total weight of 510 lbs. (231 kg). Do not place more than 210 lbs. (95 kg), including a barbell and weights, on the weight rests. Do not place more than 130 lbs. (59 kg) on the leg lever. Note: The weight bench does not include a barbell or weights.
8. Always wear athletic shoes for foot protection while using the weight bench.
9. Always keep children under age 12 and pets away from the weight bench.
10. Always place the same amount of weight on both ends of your barbell. Always keep some weight on both ends of the barbell while adding or removing weights to prevent the barbell from tipping.
11. Before using the leg lever, place a barbell with the same amount of weight on the weight rests to balance the weight bench.
12. Always exercise with a partner. When you are performing bench press exercises, your partner should stand behind you to catch the barbell if you cannot complete a repetition.
13. Before using the backrest in the level position or in an inclined position, make sure that the backrest support is properly inserted (see ADJUSTING THE BACKREST on page 11).
14. Over exercising may result in serious injury or death. If you feel faint or if you experience pain while exercising, stop immediately and cool down.

# BEFORE YOU BEGIN

Thank you for selecting the new WEIDER® 340 LC weight bench. The 340 LC weight bench offers a selection of exercises designed to develop the major muscle groups of the body. Whether your goal is to tone your body, build dramatic muscle size and strength, or improve your cardiovascular system, the weight bench will help you to achieve the specific results you want.

**For your benefit, read this manual carefully before using the weight bench.** If you have questions after

reading this manual, please see the front cover of this manual. To help us assist you, note the product model number and serial number before contacting us. The model number and the location of the serial number decal are shown on the front cover of this manual.

Before reading further, please review the drawing below and familiarize yourself with the parts that are labeled.

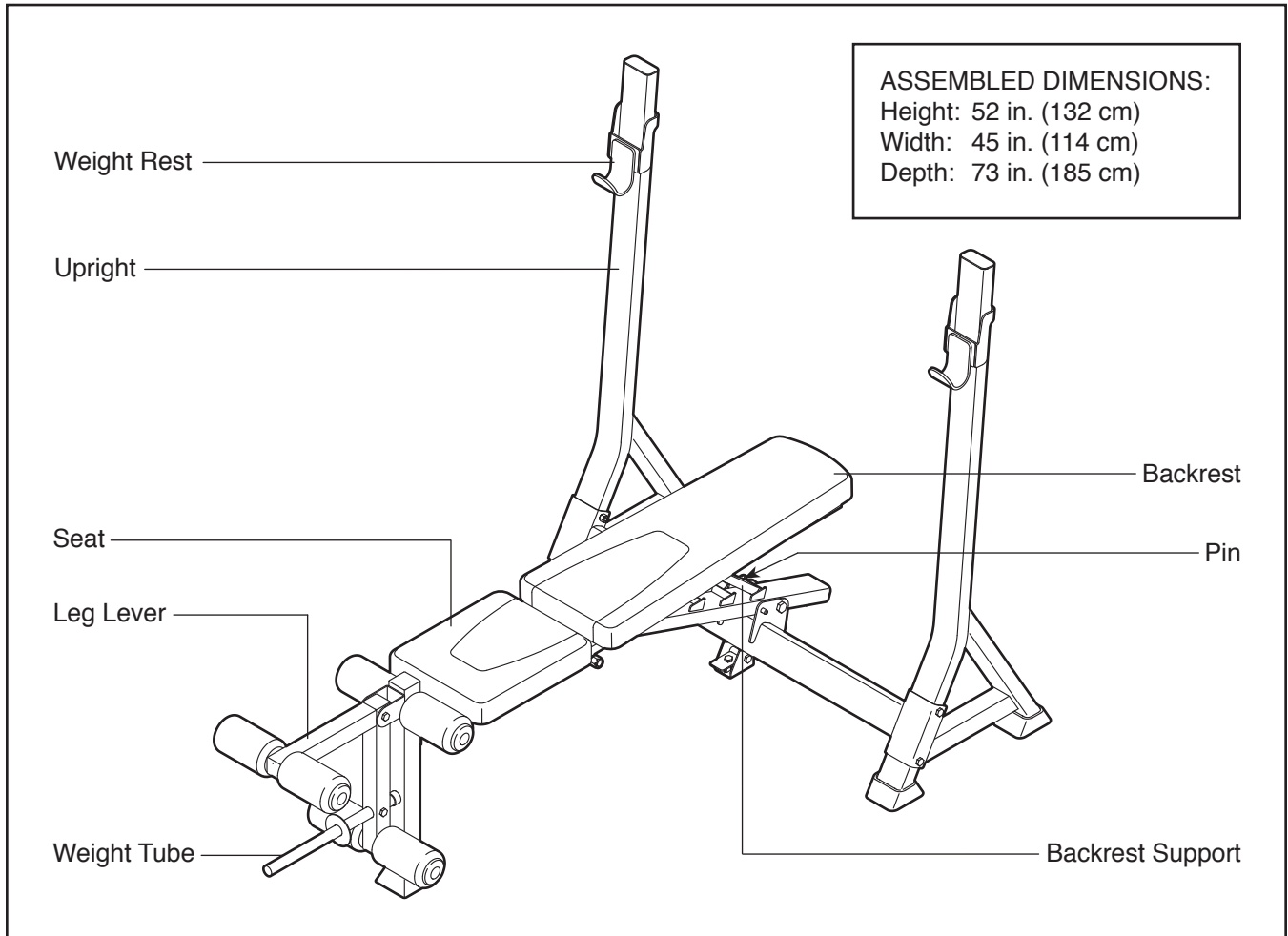

# PART IDENTIFICATION CHART

See the drawings below to identify small parts used in assembly. The number in parentheses by each drawing is the key number of the part, from the PART LIST near the end of this manual. **Note: If a part is not in the hardware kit, check to see if it has been preattached. To avoid damaging parts, do not use power tools for assembly.**

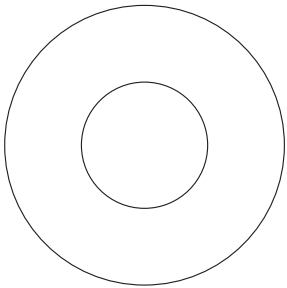

M16 Washer (41)

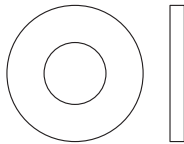

M8 Washer (30)



M6 Washer (44)

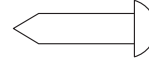

M4 x 16mm Screw (37)

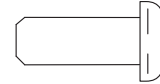

M6 x 16mm Screw (33)



M6 x 40mm Screw (34)

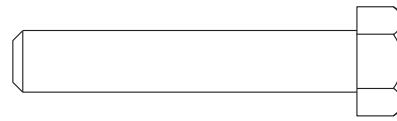

M8 x 45mm Bolt (43)

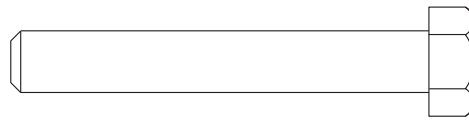

M8 x 55mm Bolt (31)

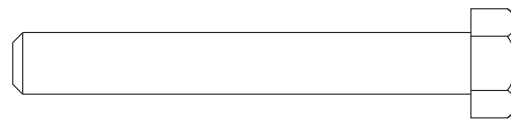

M8 x 60mm Bolt (35)

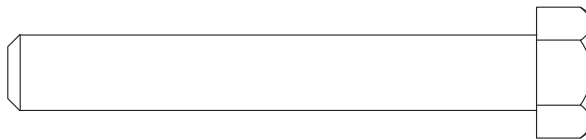

M10 x 70mm Bolt (36)

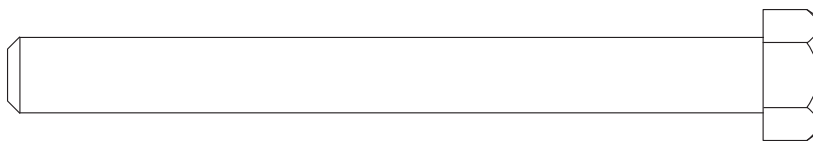

M10 x 100mm Bolt (39)

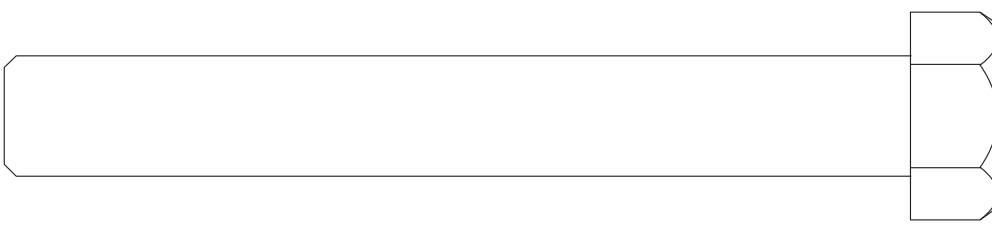

M16 x 120mm Bolt (40)

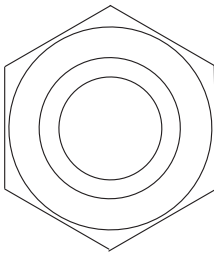

M16 Locknut (42)

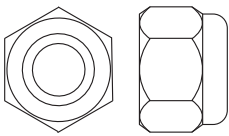

M10 Locknut (38)

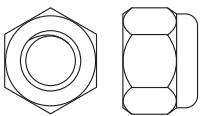

M8 Locknut (32)



Weight Tube Bushing (29)

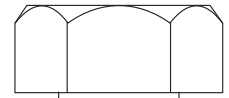

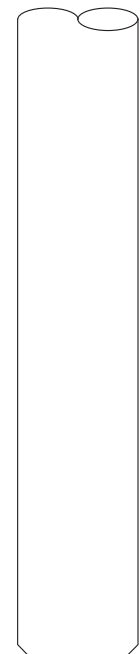

M16 x 240mm Bolt (13)



# ASSEMBLY

- Assembly requires two persons.
- Because of its size and weight, assemble the weight bench in the location where it will be used. Make sure that there is enough clearance to walk around the weight bench as you assemble it.
- Place all parts in a cleared area and remove the packing materials. Do not dispose of the packing materials until you complete all assembly steps.
- To identify small parts, see page 5.

- The following tools (not included) may be required for assembly:

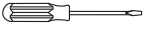
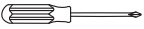
- two adjustable wrenches 
- one rubber mallet 
- one standard screwdriver 
- one Phillips screwdriver 

Assembly will be more convenient if you have a socket set, a set of open-end or closed-end wrenches, or a set of ratchet wrenches.

1.

To make assembly easier, read the assembly tips in the box above before you begin.

Orient the Crossbar (5) and an Upright (1) as shown.

Attach the Crossbar (5) to the Upright (1) with two M10 x 100mm Bolts (39) and two M10 Locknuts (38). **Do not tighten the Locknuts yet.**

**Attach the Crossbar (5) to the other Upright (1) in the same way.**

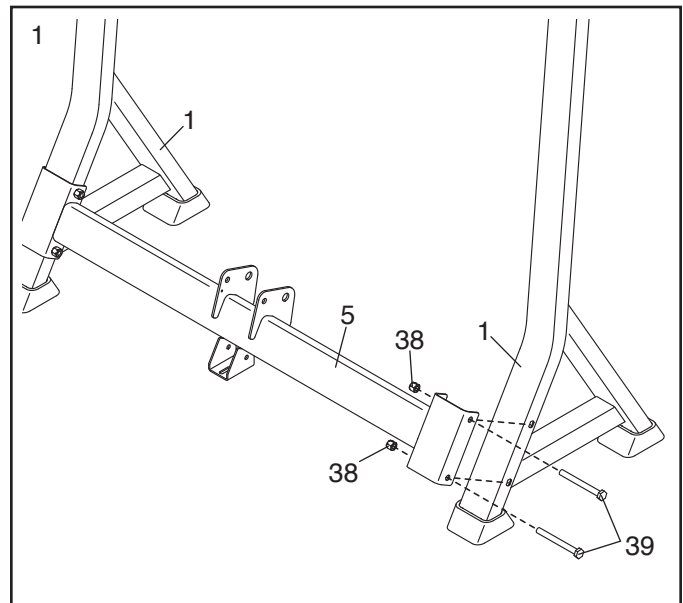

2. Orient the Front Leg (10) and the Main Frame (7) as shown.

Attach the Front Leg (10) to the Main Frame (7) with three M8 x 60mm Bolts (35), six M8 Washers (30), and three M8 Locknuts (32). **Do not tighten the Locknuts yet.**

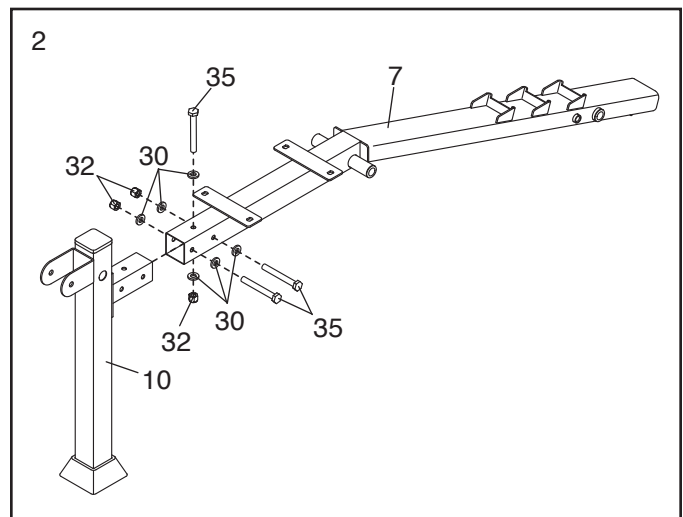

- Orient the Folding Lever (6) as shown, and insert it into the lower bracket on the Crossbar (5).

Attach the Folding Lever (6) to the Crossbar (5) with an M8 x 60mm Bolt (35) and an M8 Locknut (32). **Do not overtighten the Locknut; the Folding Lever should pivot freely.**

Then, attach the Folding Lever (6) and the Spring (17) with an M8 x 45mm Bolt (43), an M8 Washer (30), and an M8 Locknut (32). **Tighten the Locknut until three threads of the Bolt are below the Locknut.**

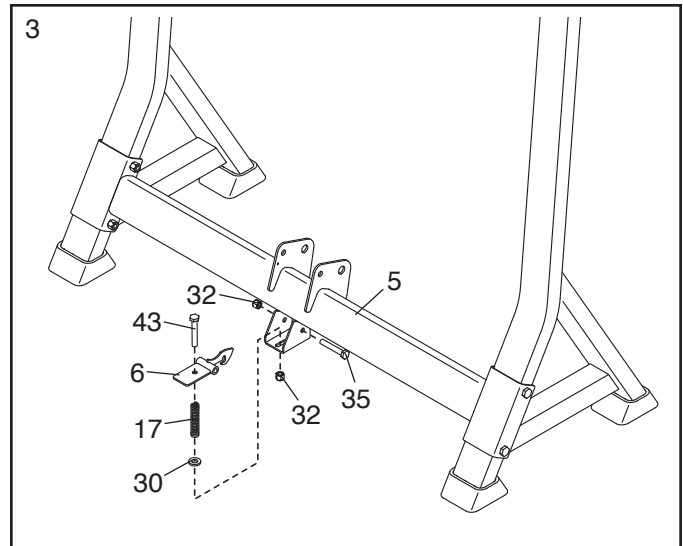

- Attach the Main Frame (7) to the Crossbar (5) with an M16 x 120mm Bolt (40) and an M16 Locknut (42). **Do not overtighten the Locknut; the Main Frame should pivot freely.**

Attach the tether on the Pin (22) to the Crossbar (5) with an M4 x 16mm Screw (37).

Then, insert the Pin (22) through the Crossbar (5) and the Main Frame (7).

**See steps 1 and 2.** Tighten the M10 Locknuts (38) and the M8 Locknuts (32).

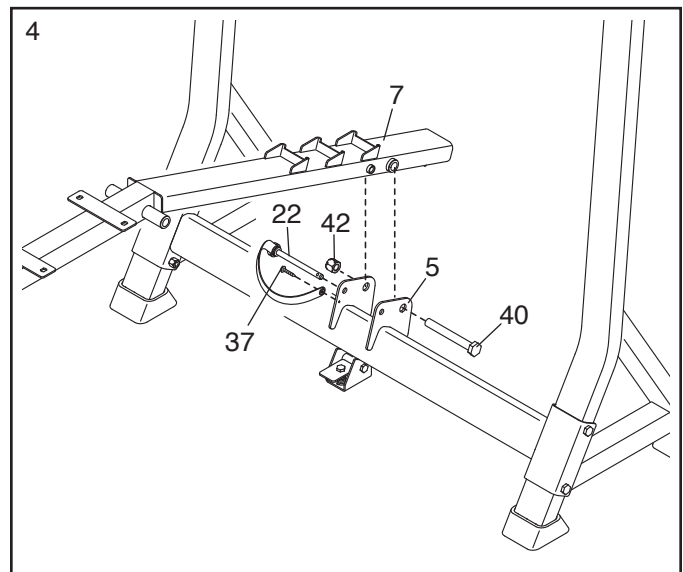

- Orient the Leg Lever (11) and the Weight Tube (12) as shown.

Attach the Weight Tube (12) to the Leg Lever (11) with an M8 x 55mm Bolt (31), two M8 Washers (30), a Weight Tube Bushing (29), and an M8 Locknut (32).

Press the Bumper (25) onto the end of the Weight Tube (12).

Apply some of the included grease to an M10 x 70mm Bolt (36).

Attach the Leg Lever (11) to the Front Leg (10) with the M10 x 70mm Bolt (36) and an M10 Locknut (38). **Do not overtighten the Locknut; the Leg Lever must pivot easily.**

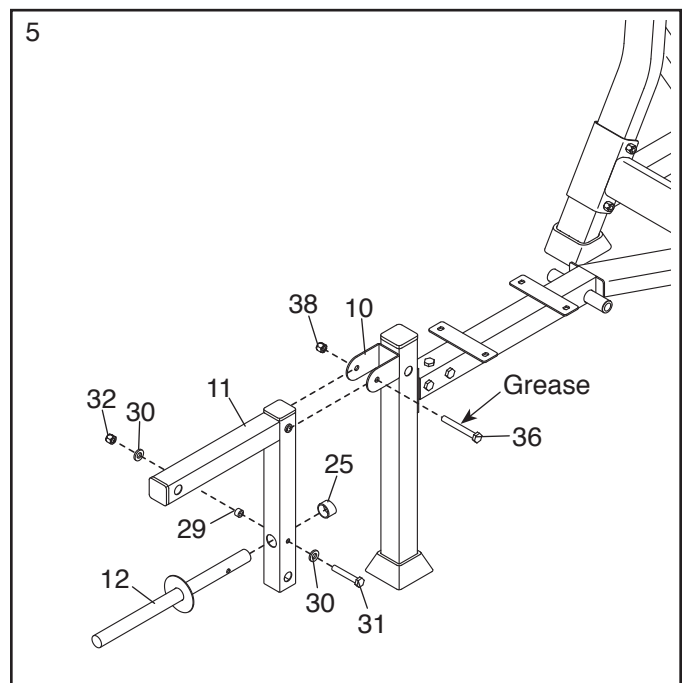

6. Attach the Seat (15) to the Main Frame (7) with four M6 x 16mm Screws (33).

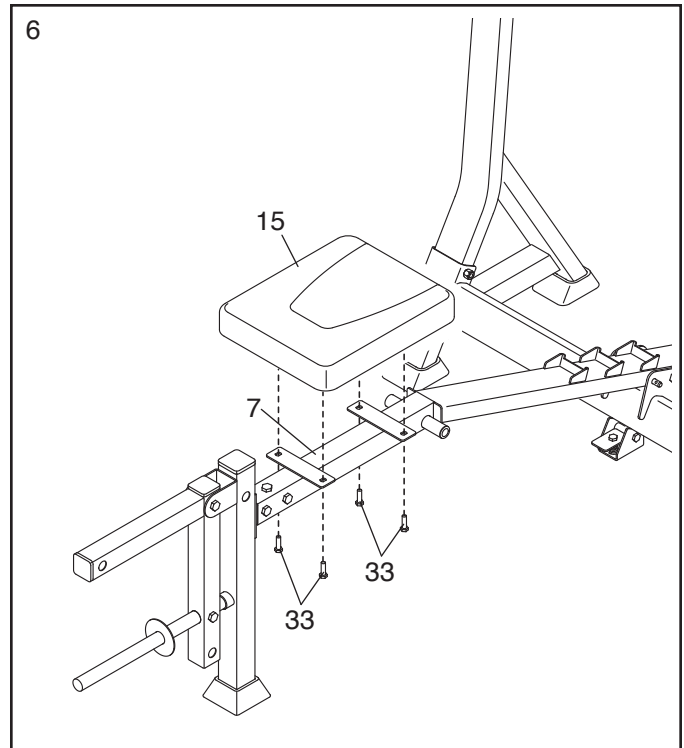

7. Identify Backrest Frames A and B (8, 9) and orient them so that the welded tubes are in the locations shown.

Then, identify the Backrest Support (4) and the Short Axle (3). Insert the Short Axle through the Backrest Support.

Next, press a Backrest Frame (8, 9) onto each end of the Short Axle (3).

Attach the Backrest (16) to the Backrest Frames (8, 9) with four M6 x 40mm Screws (34) and four M6 Washers (44).

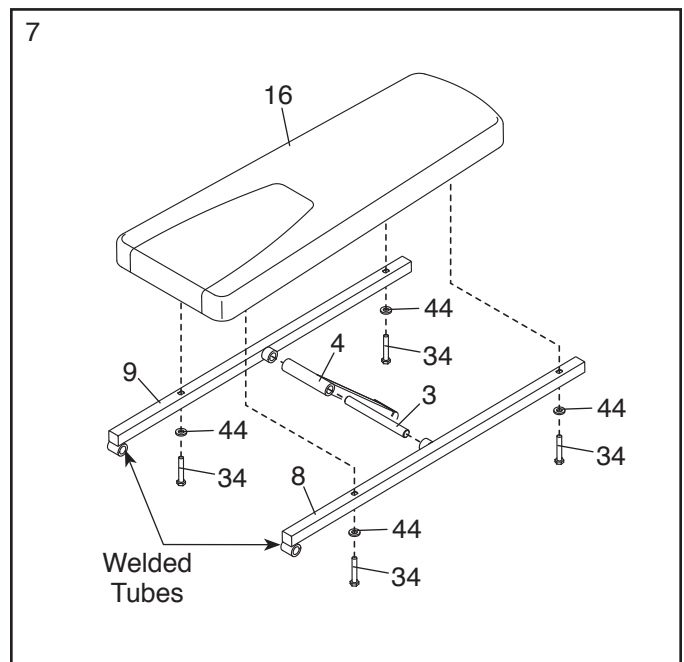



8. Apply grease to an M16 x 240mm Bolt (13).

Align the welded tubes on the Backrest Frames (8, 9) with the welded tube on the Main Frame (7).

Attach the Backrest Frames (8, 9) to the Main Frame (7) with the M16 x 240mm Bolt (13), two M16 Washers (41), and an M16 Locknut (42).

**Do not overtighten the Locknut; the Backrest Frames must pivot easily.**

Set the Backrest Support (4) in an adjustment bracket on the Main Frame (7).

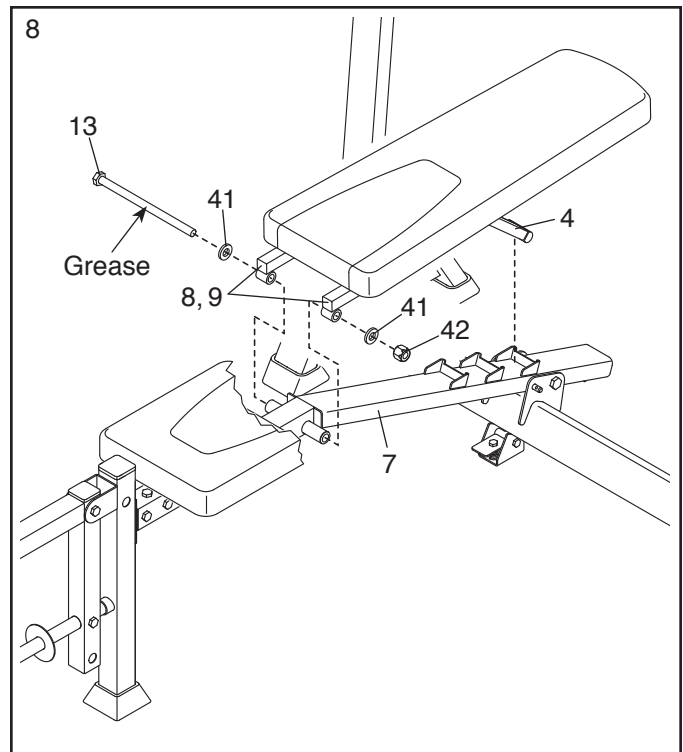

9. Insert a Pad Tube (14) through the Front Leg (10).

Slide a Foam Pad (28) onto each end of the Pad Tube (14). Then, press a Pad Cap (27) into each end of the Pad Tube.

**Repeat this step to attach the other Pad Tubes (not shown), Foam Pads (28), and Pad Caps (27) to the Leg Lever (11).**

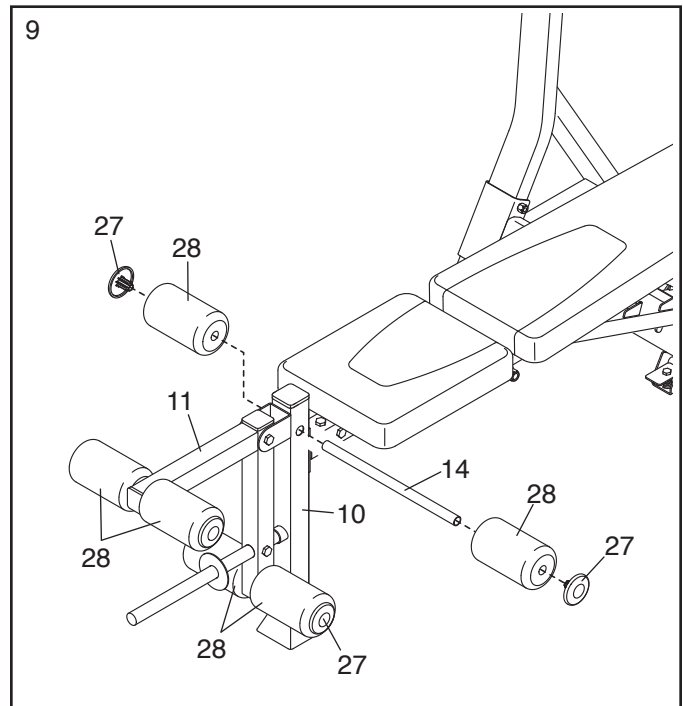

10. Slide a Weight Rest (2) onto an Upright (1). Insert the hook on the Weight Rest into an adjustment hole in the Upright. **Make sure that the Weight Rest is securely engaged in an adjustment hole.**

**Repeat this step on the other side of the weight bench.**

**Make sure that the Weight Rests (2) are at the same height.**

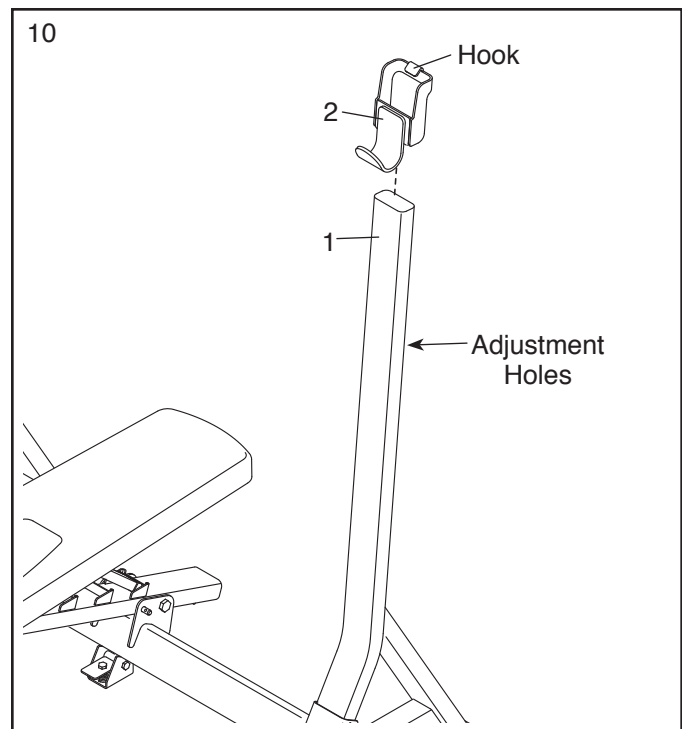

11. **Make sure that all parts are properly tightened before you use the weight bench.** The use of the remaining parts will be explained in ADJUSTMENT, beginning on page 11.

# ADJUSTMENT

This section explains how to adjust the weight bench. See the EXERCISE GUIDELINES on page 13 for important information about how to get the most benefit from your exercise program. Also, refer to the accompanying exercise guide to see the correct form for each exercise.

Make sure all parts are properly tightened each time you use the weight bench. Replace any worn parts immediately. The weight bench can be cleaned with a damp cloth and a mild, non-abrasive detergent. Do not use solvents.

## ADJUSTING THE BACKREST

To adjust the position of the Backrest (16), raise or lower the Backrest, and set the Backrest Support (4) in one of the adjustment brackets in the Main Frame (7).

**WARNING:** Make sure that the Backrest Support (4) is fully inserted into one of the adjustment brackets.

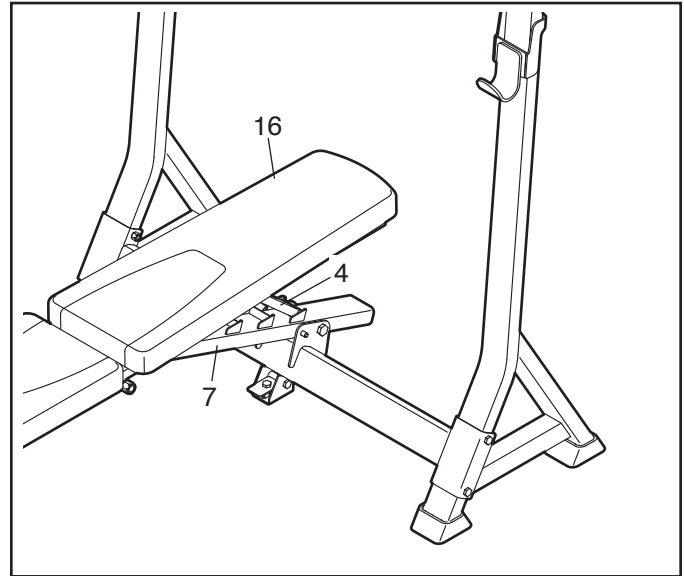

## USING THE LEG LEVER

To use the Leg Lever (11), slide a weight plate (not included) onto the Weight Tube (12) and secure it with a Weight Clip (47).

To use Olympic weight plates (not included), remove the M8 x 10mm Set Screw (49) from the Olympic Adapter (48), slide the Olympic Adapter onto the Weight Tube (12), and then tighten the M8 x 10mm Set Screw into the Olympic Adapter and the Weight Tube.

Slide an Olympic weight plate onto the Olympic Adapter (48) and secure it with a large weight clip (not included).

**WARNING:** Do not place more than 130 lbs. (59 kg) on the Leg Lever (11).

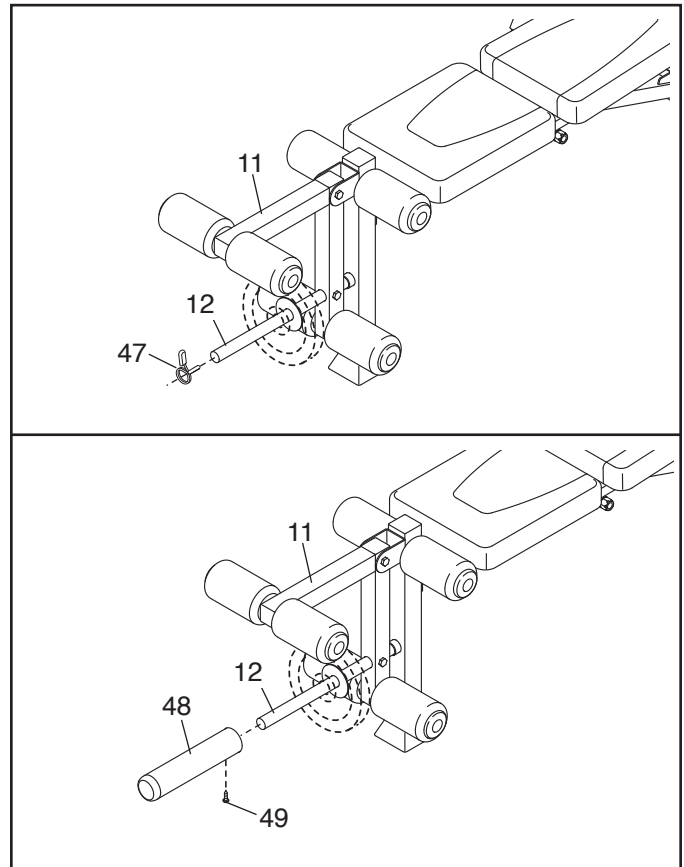

## ADJUSTING THE WEIGHT RESTS

To adjust the height of a Weight Rest (2), lift the hook on the Weight Rest, slide the Weight Rest to the desired height, and then insert the hook into an adjustment hole in the Upright (1).

**Adjust the position of the other Weight Rest (2) in the same way.**

**⚠ WARNING:** Make sure that each Weight Rest (2) is securely engaged in an adjustment hole. Always set both Weight Rests at the same height.

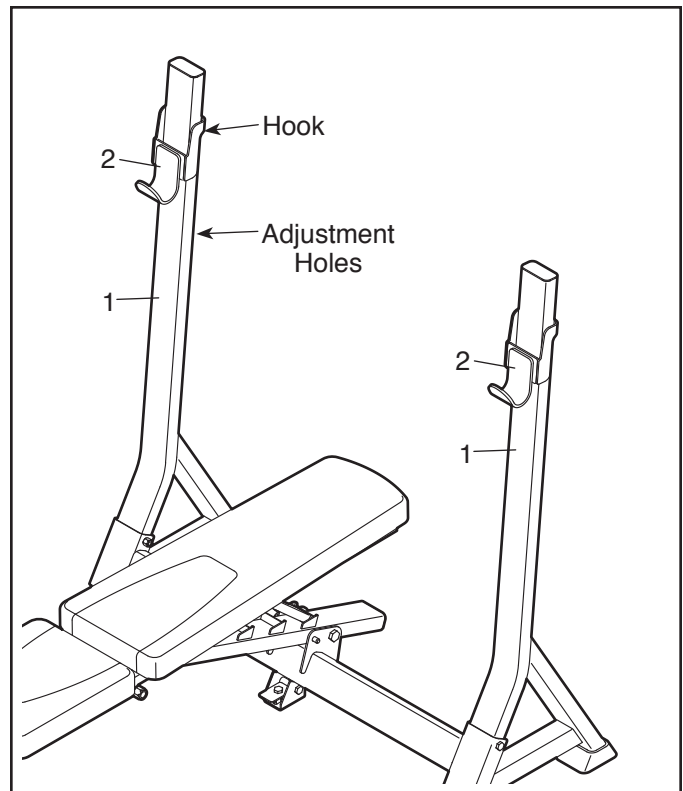

## FOLDING THE WEIGHT BENCH

To fold the weight bench for storage, first remove the Pin (22) from the Crossbar (5) and the Main Frame (7). Next, lift the Main Frame upward to the position shown. Then, reinsert the Pin into the Crossbar and the Main Frame.

To unfold the weight bench, press down on the Folding Lever (6), remove the Pin (22), and lower the weight bench to the floor. Then, reinsert the Pin into the Crossbar (5) and the Main Frame (7).

**⚠ WARNING:** Make sure that the Pin (22) is securely engaged in the Crossbar (5) and the Main Frame (7).

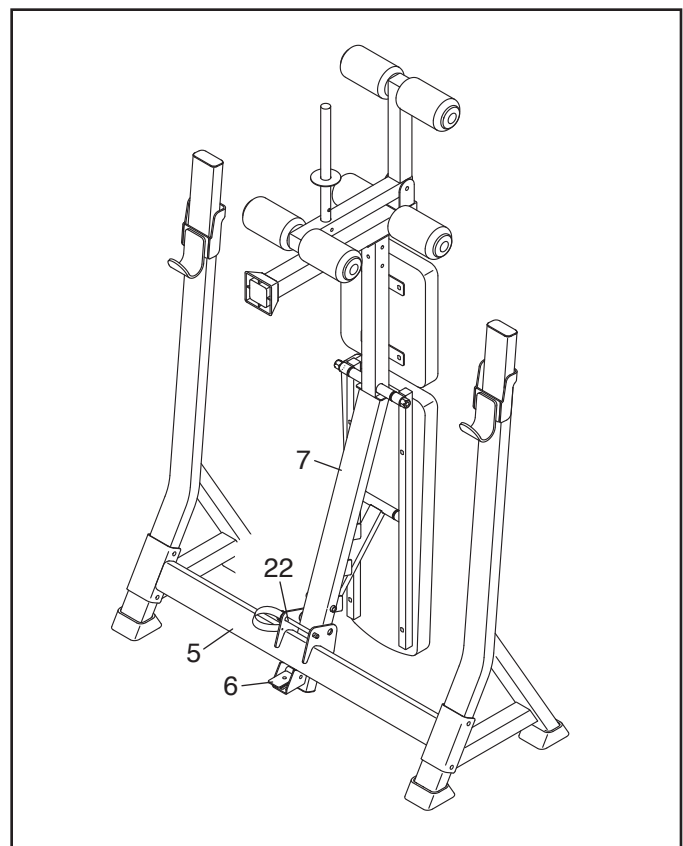

---

# EXERCISE GUIDELINES

## FOUR TYPES OF STRENGTH WORKOUTS

Note: A “repetition” is one complete cycle of an exercise, such as one sit-up. A “set” is a series of repetitions.

**Muscle Building**—Work your muscles near their maximum capacity and progressively increase the intensity of your exercise. Adjust the intensity level of an individual exercise as follows:

- Change the amount of resistance used.
- Change the number of repetitions or sets performed.

Use your own judgment to determine the amount of resistance that is right for you. Begin with 3 sets of 8 repetitions for each exercise you perform. Rest for 3 minutes after each set. When you can complete 3 sets of 12 repetitions without difficulty, increase the amount of resistance.

**Toning**—Tone your muscles by working them to a moderate percentage of their capacity. Select a moderate amount of resistance and increase the number of repetitions in each set. Complete as many sets of 15 to 20 repetitions as possible without discomfort. Rest for 1 minute after each set. Work your muscles by completing more sets rather than by using high amounts of resistance.

**Weight Loss**—To lose weight, use a low amount of resistance and increase the number of repetitions in each set. Exercise for 20 to 30 minutes, resting for a maximum of 30 seconds between sets.

**Cross Training**—Combine strength training and aerobic exercise by following this type of program:

- Strength training workouts on Monday, Wednesday, and Friday.
- 20 to 30 minutes of aerobic exercise on Tuesday and Thursday.
- One full day of rest each week to give your body time to regenerate.

## WORKOUT GUIDELINES

Familiarize yourself with the equipment and learn the proper form for each exercise. Use your own judgment to determine the appropriate length of time for each

workout, and the numbers of repetitions and sets to complete. Progress at your own pace and be sensitive to your body’s signals. Follow each workout with at least one day of rest.

**Warming Up**—Start with 5 to 10 minutes of stretching and light exercise. A warm-up increases your body temperature, heart rate, and circulation in preparation for exercise.

**Working Out**—Include 6 to 10 different exercises in each workout. Select exercises for every major muscle group, emphasizing areas that you want to develop. To give balance and variety to your workouts, vary the exercises from workout to workout.

**Cooling Down**—Finish with 5 to 10 minutes of stretching. Stretching increases the flexibility of your muscles and helps to prevent post-exercise problems.

## EXERCISE FORM

Move through the full range of motion for each exercise and move only the appropriate parts of the body. Perform the repetitions in each set smoothly and without pausing. The exertion stage of each repetition should last about half as long as the return stage. Exhale during the exertion stage of each repetition and inhale during the return stroke. Never hold your breath.

Rest for a short period of time after each set:

- Muscle Building—Rest for three minutes after each set.
- Toning—Rest for one minute after each set.
- Weight Loss—Rest for 30 seconds after each set.

## STAYING MOTIVATED

For motivation, keep a record of each workout. Write the date, the exercises performed, the resistance used, and the numbers of sets and repetitions completed. Record your weight and key body measurements once a month. To achieve good results, make exercise a regular and enjoyable part of your life.

# PART LIST

Model No. WEEVBE24910.0 R1112A

Key No.	Qty.	Description	Key No.	Qty.	Description
1	2	Upright	27	6	Pad Cap
2	2	Weight Rest	28	6	Foam Pad
3	1	Short Axle	29	1	Weight Tube Bushing
4	1	Backrest Support	30	9	M8 Washer
5	1	Crossbar	31	1	M8 x 55mm Bolt
6	1	Folding Lever	32	6	M8 Locknut
7	1	Main Frame	33	4	M6 x 16mm Screw
8	1	Backrest Frame A	34	4	M6 x 40mm Screw
9	1	Backrest Frame B	35	4	M8 x 60mm Bolt
10	1	Front Leg	36	1	M10 x 70mm Bolt
11	1	Leg Lever	37	2	M4 x 16mm Screw
12	1	Weight Tube	38	5	M10 Locknut
13	1	M16 x 240mm Bolt	39	4	M10 x 100mm Bolt
14	3	Pad Tube	40	1	M16 x 120mm Bolt
15	1	Seat	41	2	M16 Washer
16	1	Backrest	42	2	M16 Locknut
17	1	Spring	43	1	M8 x 45mm Bolt
18	4	25mm Square Inner Cap	44	4	M6 Washer
19	3	45mm Square Inner Cap	45	1	50mm Square Inner Cap
20	1	Square Outer Cap	46	3	Rectangular Inner Cap
21	4	Rectangular Outer Cap	47	1	Weight Clip
22	1	Pin	48	1	Olympic Adapter
23	12	Spacer	49	1	M8 x 10mm Set Screw
24	1	Backrest Support Cap	*	–	User's Manual
25	1	Bumper	*	–	Exercise Guide
26	1	25mm Round Cap	*	–	Grease Packet

Note: Specifications are subject to change without notice. For information about ordering replacement parts, see the back cover of this manual. \*These parts are not illustrated.

# EXPLODED DRAWING

Model No. WEEVBE24910.0 R1112A

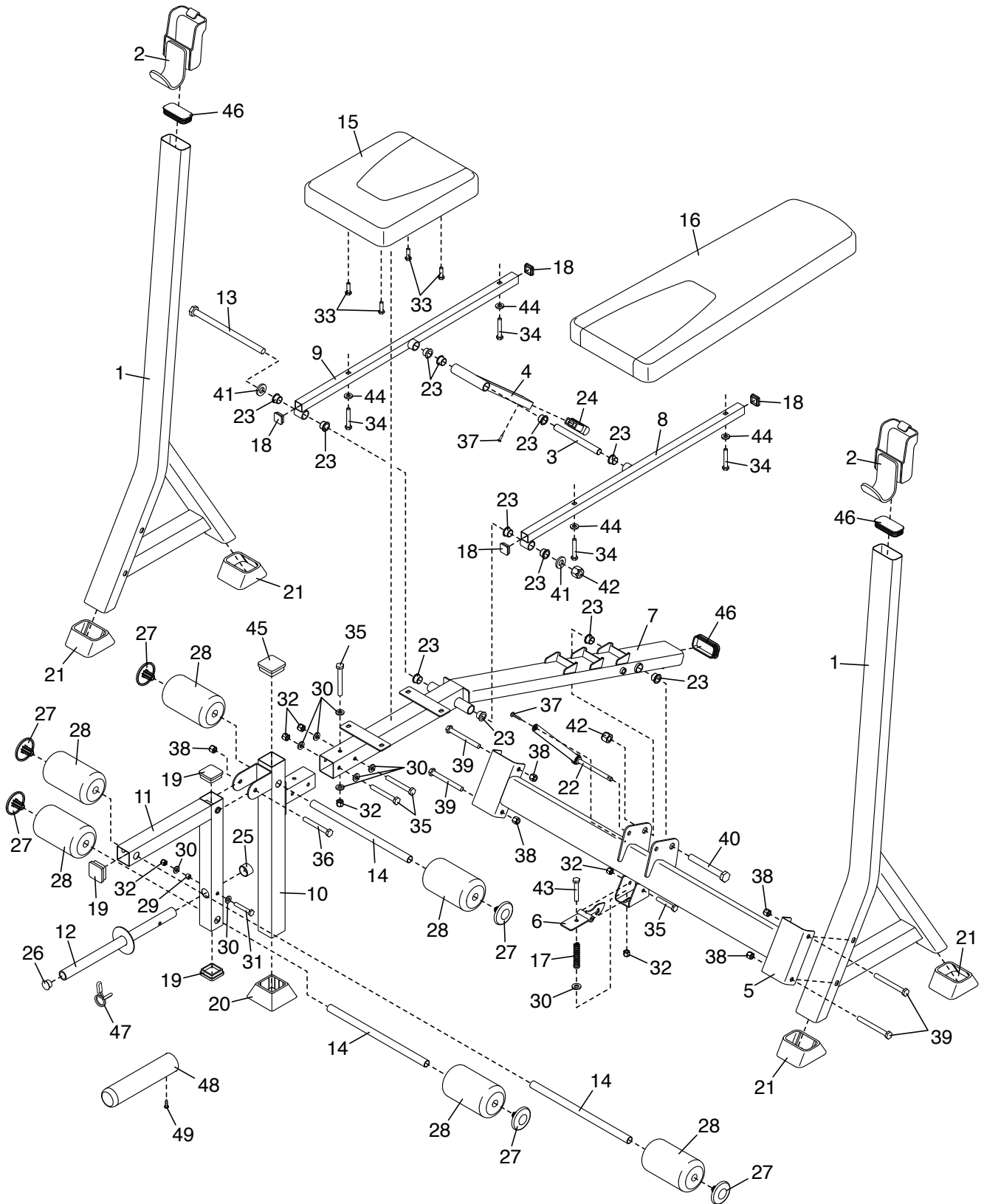

---

# ORDERING REPLACEMENT PARTS

To order replacement parts, please see the front cover of this manual. To help us assist you, be prepared to provide the following information when contacting us:

- the model number and serial number of the product (see the front cover of this manual)
- the name of the product (see the front cover of this manual)
- the key number and description of the replacement part(s) (see the PART LIST and the EXPLODED DRAWING near the end of this manual)