

WEIDER® 9025

Model No. WEEVSY20230

Serial No. _____

Write the serial number in the space above for reference.

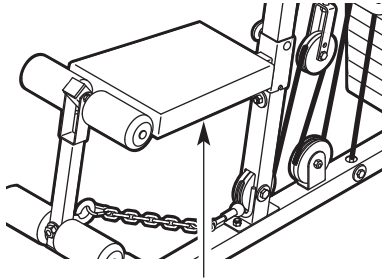

Serial Number Decal (under seat)

USER'S MANUAL

QUESTIONS?

As a manufacturer, we are committed to providing complete customer satisfaction. If you have questions, or if there are missing parts, please call:

08457 089 009

Or write:
ICON Health & Fitness, Ltd.
Unit 4
Revie Road Industrial Estate
Revie Road
Beeston
Leeds, LS118JG
UK

email: csuk@iconeurope.com

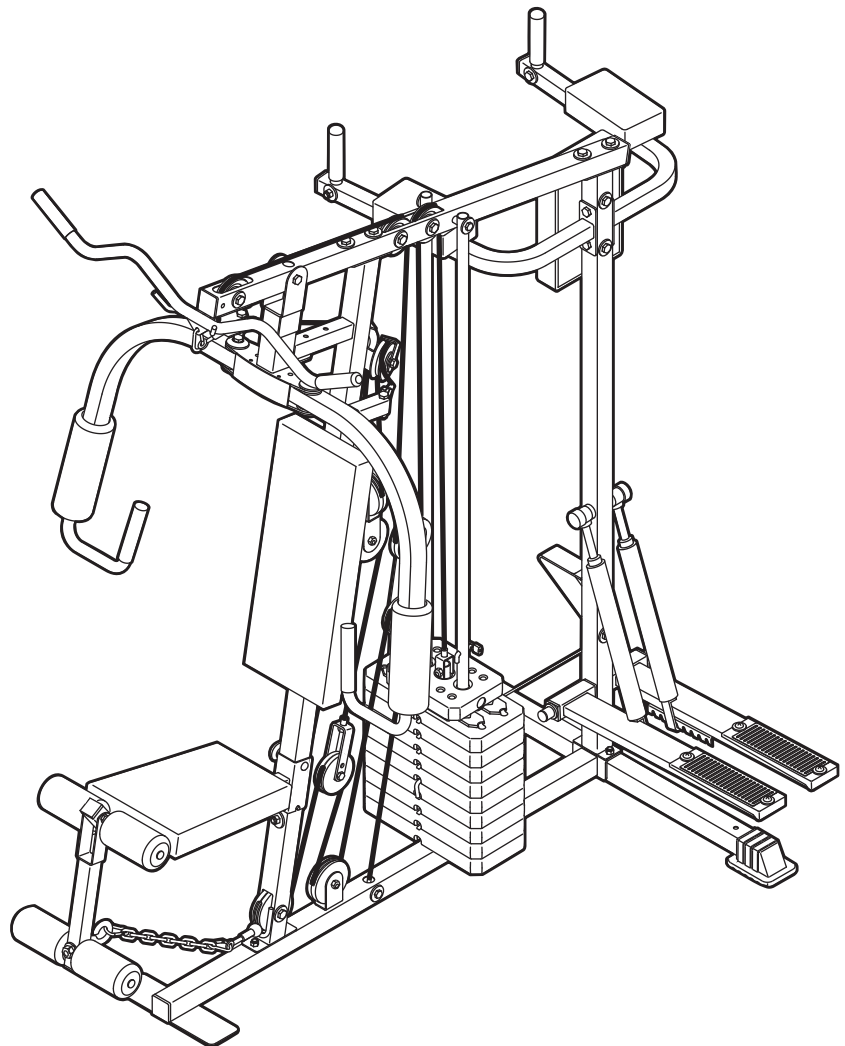

⚠ CAUTION

Read all precautions and instructions in this manual before using this equipment. Save this manual for future reference.



Visit our website at

www.iconeurope.com

TABLE OF CONTENTS

WARNING DECAL PLACEMENT	2
IMPORTANT PRECAUTIONS	3
BEFORE YOU BEGIN	4
ASSEMBLY	5
ADJUSTMENT	16
WEIGHT RESISTANCE CHART	18
TROUBLESHOOTING	19
CABLE DIAGRAM	20
EXERCISE GUIDELINES	21
ORDERING REPLACEMENT PARTS	Back Cover

Note: A PART IDENTIFICATION CHART and a PARTS LIST/EXPLODED DRAWING are attached at the centre of this manual. Remove them before beginning assembly.

WARNING DECAL PLACEMENT

The decals shown here have been placed on the weight system in the locations shown on page 4. If a decal is missing or illegible, please call our Customer Service Department 08457 089 009 to order a free replacement decal. Apply the decal in the location shown.

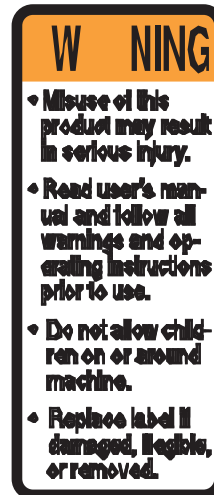

Warning Decal 1



Warning Decal 2



Warning Decal 3



Warning Decal 4

IMPORTANT PRECAUTIONS

⚠ WARNING: To reduce the risk of serious injury, read the following important precautions before using the weight system.

1. Read all instructions in this manual and in the accompanying literature before using the weight system.
2. It is the responsibility of the owner to ensure that all users of the weight system are adequately informed of all precautions.
3. The weight system is intended for home use only. Do not use the weight system in any commercial, rental, or institutional setting.
4. Use the weight system only on a level surface. Cover the floor beneath the weight system to protect the floor.
5. Make sure all parts are properly tightened each time the weight system is used. Replace any worn parts immediately.
6. Keep children under 12 and pets away from the weight system at all times.
7. Keep hands and feet away from moving parts.
8. The weight system is designed to support a maximum user weight of 135 kg (300 lbs.).
9. Always wear athletic shoes for foot protection.
10. Always stand on the foot plate when performing an exercise that could cause the weight system to tip.
11. Never release the press arm, fly arms, leg lever, lat bar, ankle strap, or handle whilst weights are raised; the weights will fall with great force.
12. *Always disconnect the lat bar from the weight system when performing an exercise that does not use the lat bar.*
13. Make sure that the cables remain on the pulleys at all times. If the cables bind whilst you are exercising, stop immediately and make sure that the cables are on all of the pulleys.
14. The resistance cylinders become very hot during use. Allow the cylinders to cool before touching them.
15. If you feel pain or dizziness at any time whilst exercising, stop immediately and begin cooling down.

⚠ WARNING: Before beginning this or any exercise program, consult your physician. This is especially important for persons over the age of 35 or persons with pre-existing health problems. Read all instructions before using. ICON assumes no responsibility for personal injury or property damage sustained by or through the use of this product.

BEFORE YOU BEGIN

Thank you for selecting the versatile WEIDER® 9025 weight system. The weight system offers a selection of weight stations designed to develop every major muscle group of the body. Whether your goal is to tone your body, build dramatic muscle size and strength, or improve your cardiovascular system, the weight system will help you to achieve the specific results you want.

For your benefit, read this manual carefully before using the weight system. If you have questions after

reading this manual, please call our Customer Service Department at **08457 089 009**. To help us assist you, please note the product model number and serial number before calling. The model number is WEEVSY20230. The serial number can be found on a decal attached to the weight system (see the front cover of this manual).

Before reading further, please review the drawing below and familiarise yourself with the parts that are labelled.

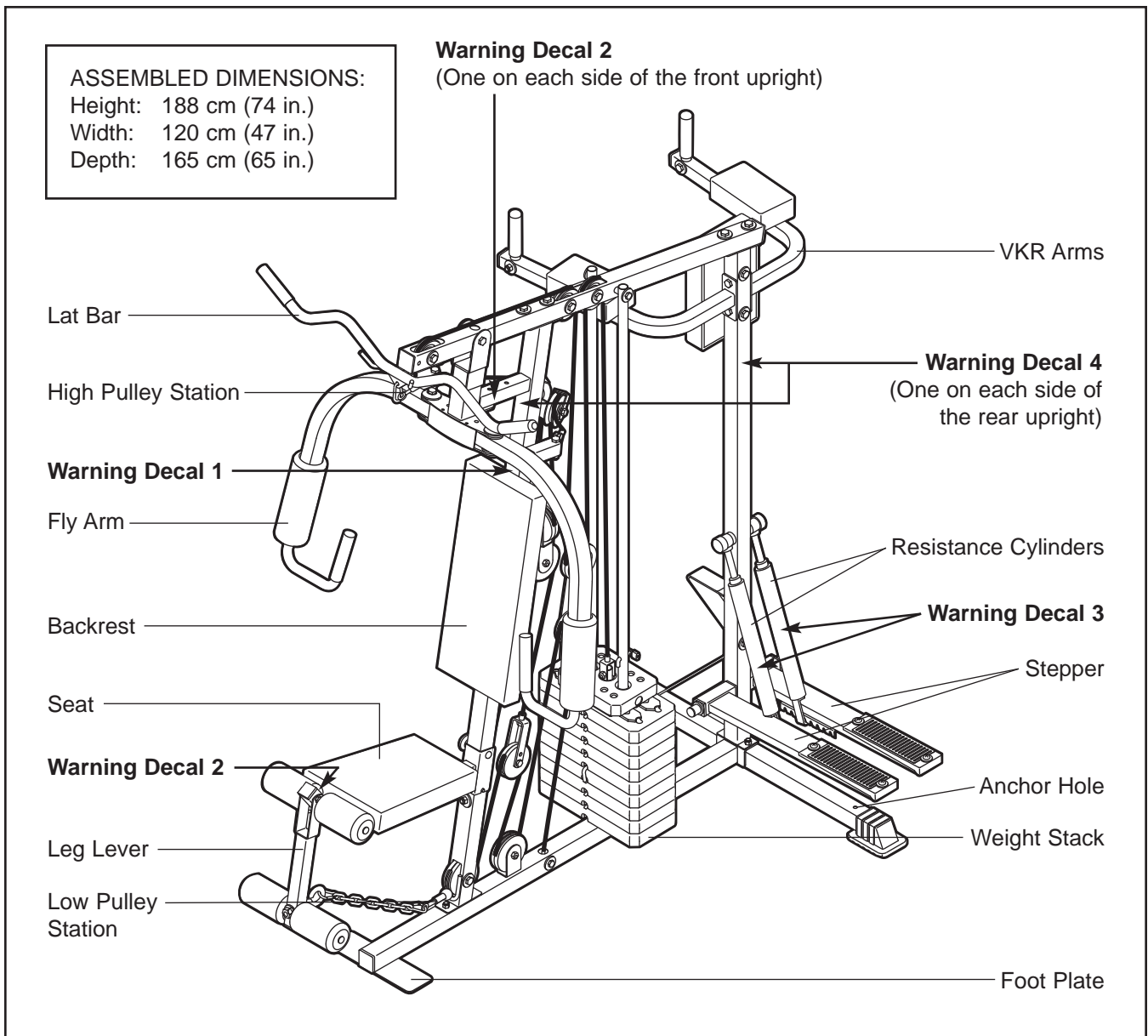

ASSEMBLY

Make Things Easier for Yourself





Everything in this manual is designed to ensure that the weight system can be assembled successfully by anyone. However, it is important to realise that the versatile weight system has many parts and that the assembly process will take time. Most people find that by setting aside plenty of time, assembly will go smoothly.

Before beginning assembly, carefully read the following information and instructions:

- Assembly requires two people.
- To make assembly as easy as possible, we have divided the assembly process into four stages. The parts needed for each stage are found in individual bags. **Important: Wait until you begin each stage to open the parts bag for that stage.** Place all parts of the weight system in a cleared area and remove the packing materials. Do not dispose of the packing materials until assembly is completed.

- Tighten all parts as you assemble them, unless instructed to do otherwise.
- As you assemble the weight system, make sure all parts are oriented as shown in the drawings.
- For help identifying small parts, use the **PART IDENTIFICATION CHART**.

The following tools (not included) are required for assembly:

- **two adjustable spanners** 
- **one rubber mallet** 
- **one standard screwdriver** 
- **one Phillips screwdriver** 
- **lubricant, such as grease or petroleum jelly, and soapy water.**

Assembly will be more convenient if you have a socket set, a set of open-end or closed-end spanners, or a set of ratchet spanners.

Frame Assembly

1.

Before you begin, make sure that you have carefully read the instructions at the top of this page.

Attach a Base Cap (32) to the Stabiliser (2) with two M4 Washers (75) and two M4 x 16mm Self-tapping Screws (74). **Attach another Base Cap to the Stabiliser in the same manner.**

Insert two M8 x 67mm Carriage Bolts (82) and an M10 x 67mm Carriage Bolt (107) up through the Stabiliser (2). **It may be helpful to place a piece of tape over the bolt head to hold it in place.**

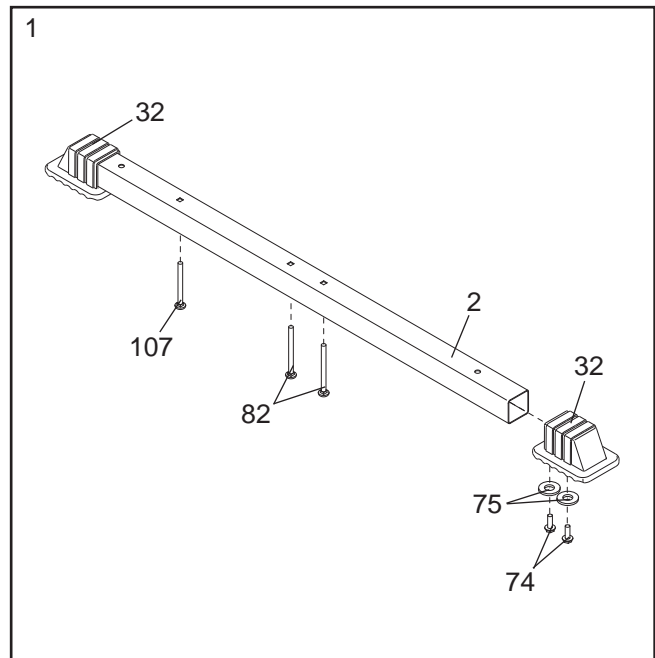

2. **See the inset drawing.** Press a 50mm Square Inner Cap (31) into the Base (1). Insert two M10 x 65mm Carriage Bolts (81) up through the Base. **It may be helpful to place a piece of tape over the bolt head to hold it in place.**

Attach the Base (1) and the Rear Upright (3) to the Stabiliser with the indicated M8 x 67mm Carriage Bolts (82) and two M8 Nylon Locknuts (73). **Do not tighten the Locknuts yet.**

Attach the Support Bracket (33) to the M10 x 67mm Carriage Bolt (107) with an M10 Star Washer (92) and an M10 Nylon Locknut (72). **Do not tighten the Locknuts yet.**

Orient the Support Bracket (33) as shown. Attach the Support Bracket to the Rear Upright (3) with an M10 x 72mm Bolt (89), an M10 Washer (71), and an M10 Nylon Locknut (72). **Do not tighten the Locknuts yet.**

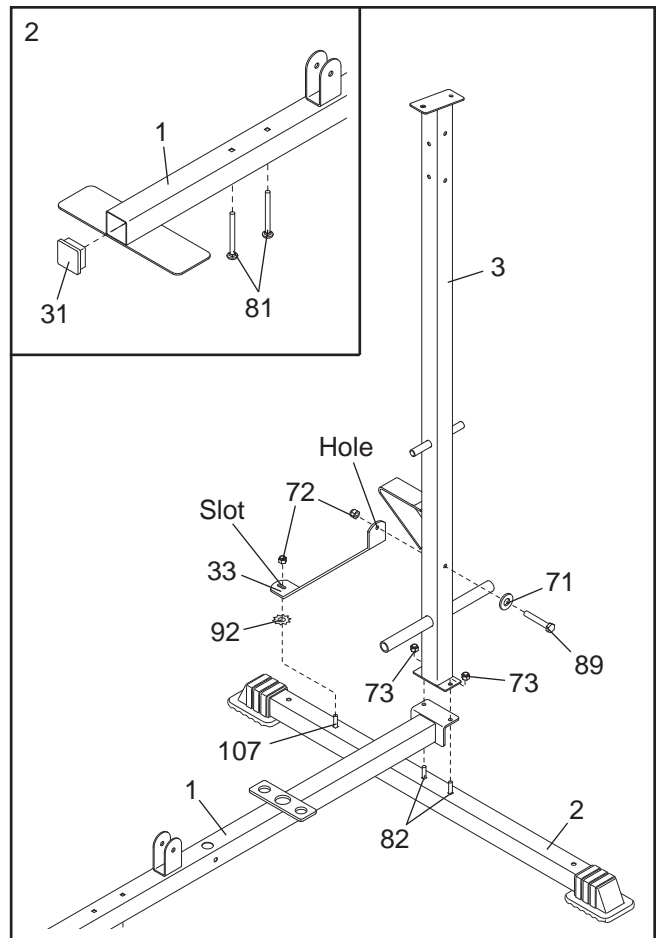

3. Press a 38mm Square Inner Cap (29) into the Front Upright (4).

Attach the Front Upright (4) to the Base (1) with the indicated M10 x 65mm Carriage Bolts (81) and two M10 Nylon Locknuts (72). **Do not tighten the Locknuts yet.**

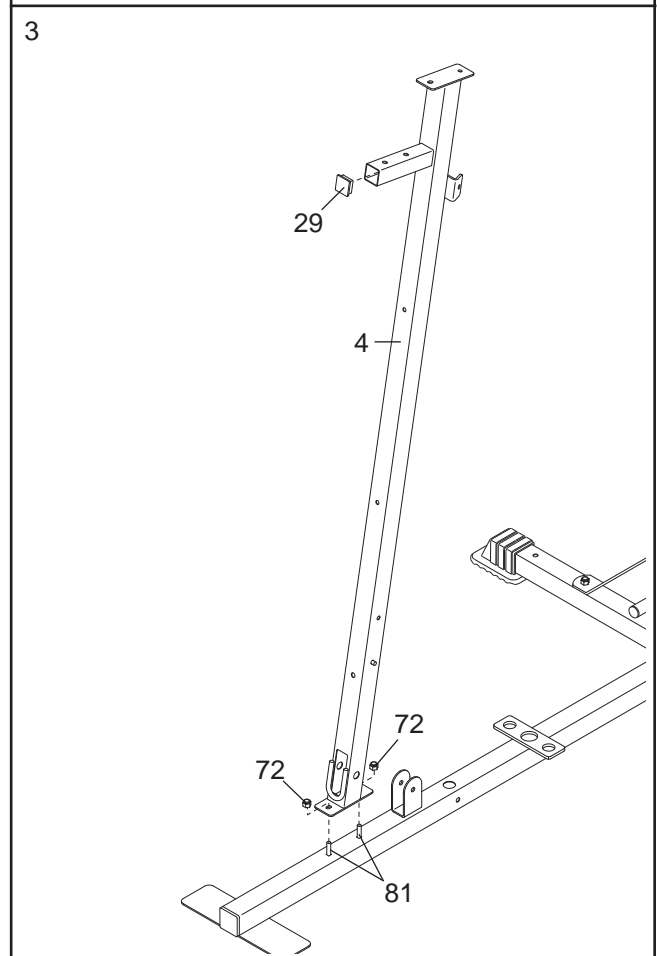

4. Insert two Weight Guides (5) into the Base (1). Make sure that the holes are on the top.

Slide two Weight Bumpers (44) onto the Weight Guides (5). Slide the nine Weights (16) onto the Weight Guides.

Press the Weight Tube Bumper (17) into the Weight Tube (18). Insert the Weight Tube into the stack of Weights (16) as shown.

Lubricate the indicated holes in the Top Weight (19) with grease. Slide the Top Weight onto the Weight Guides (5). **Make sure the pin on the Weight Tube (18) rests in the pin grooves on the bottom of the Top Weight.**

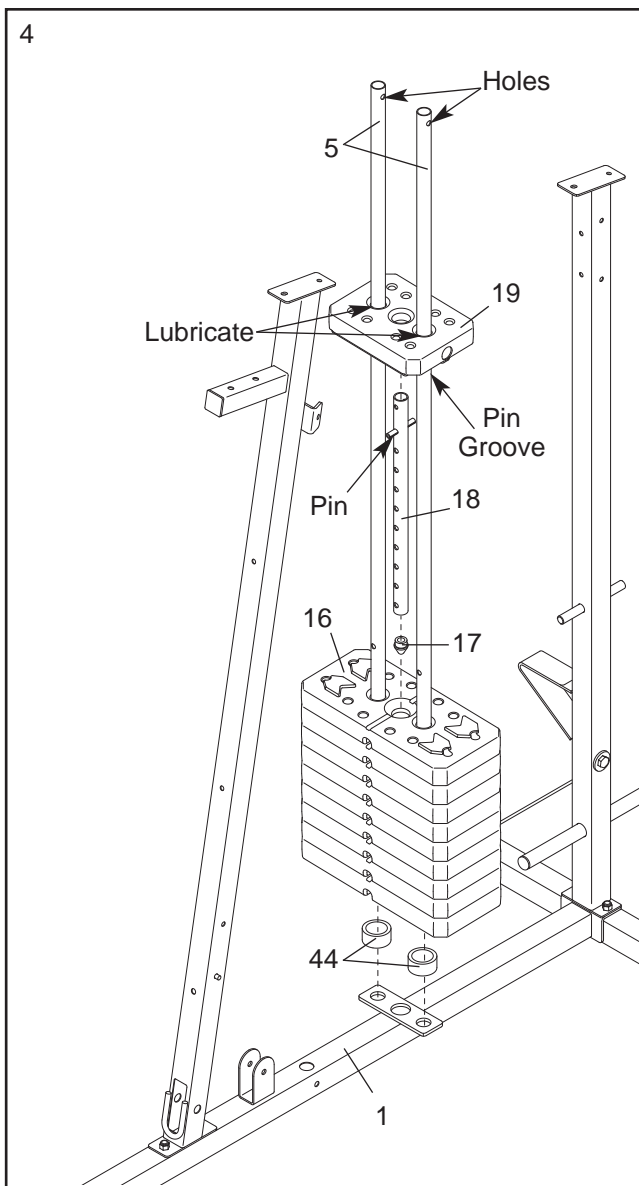

5. Press two 50mm Square Inner Caps (31) into the Top Frame (6).

Attach the Top Frame (6) to the Front and Rear Uprights (4, 3) with four M10 x 68mm Bolts (87), four M10 Washers (71), and four M10 nylon Locknuts (72). **Do not tighten the Locknuts yet.**

Attach the Weight Guides (5) to the Top Frame (6) with an M10 x 153mm Bolt (91), two M10 Washers (71), two 18mm Spacers (109), and an M10 Nylon Locknut (72). **Do not tighten the Locknuts yet.**

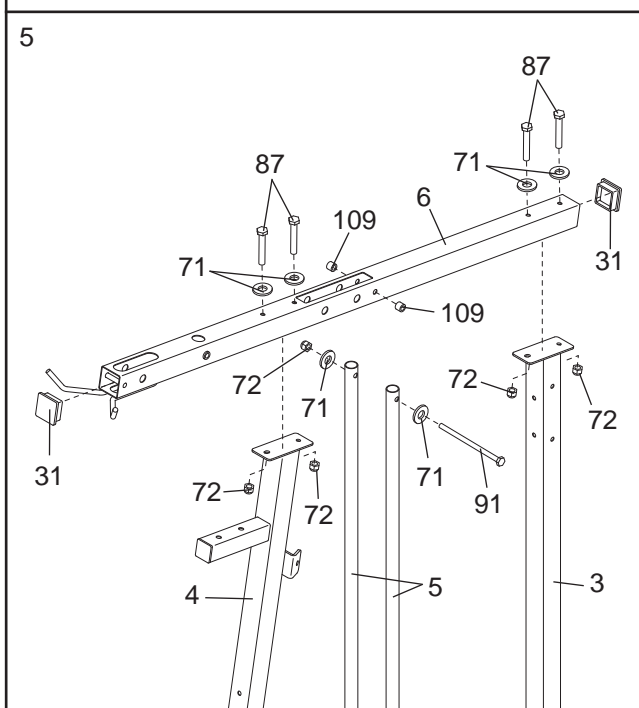

- Press two 38mm Square Bushings (35) into the Right Pedal (14); Attach a Pedal Cover (36) to the Pedal with two M4 x 16mm Self-tapping Screws (74) and two M4 Washers (75).

Lubricate the pedal axles on the Rear Upright (3). Slide the Right Pedal (14) onto the pedal axle. **Make sure that the Pedal is on the correct side; the slotted brackets must be on the inside of the Pedal.**

Hold a 25mm Retainer (98) and 25mm Round Outer Cap (30) against the right pedal axle. **The teeth on the Retainer must bend toward the Round Cover Cap (see the inset drawing in step 7).** Tap the Retainer and Round Outer Cap onto the pedal axle.

Attach the Left Pedal (15) in the same manner.

- Lubricate the cylinder axles on the Rear Upright (3) with grease.

Slide a 16mm Round Bushing (40) and a Resistance Cylinder (37) onto the right cylinder axle. **Make sure that the Bushing, Cylinder, and warning decal are oriented as shown.** Hold a 16mm Retainer (39) and a 16mm Round Outer Cap (38) against the right cylinder axle. **The teeth on the Retainer must bend toward the Outer Cap (see the inset drawing).** Tap the Retainer and Outer Cap onto the cylinder axle.

Raise the Right Pedal (14) and rest it on the hook at the lower end of the Resistance Cylinder (37). **The hook must be in one of the slots under the right Pedal.**

Repeat this step with the other Resistance Cylinder (37) on the left side of the Rear Upright (3). Tighten the Nylon Locknuts (72, 73) used in steps 2–7.

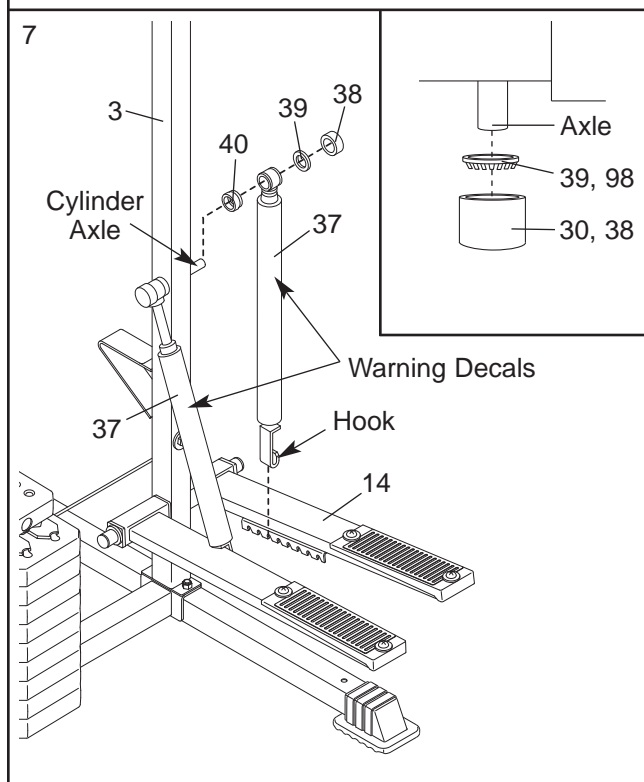
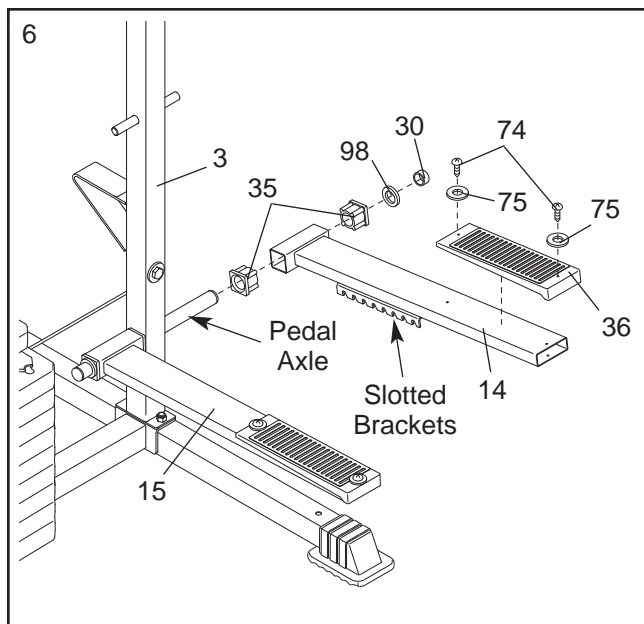

Arm Assembly

- Press a 50mm x 70mm Inner Cap (103) into the Butterfly Frame (11).

Attach the tethers on the two “L”-pins (100) to the Butterfly Frame (11) with an M4 x 16mm Self-tapping Screw (74).

Lubricate an M10 x 80mm Bolt (83) with grease. Attach the Butterfly Frame (11) to the Top Frame (6) with the Bolt and an M10 Nylon Locknut (72). **Do not overtighten the Locknut; the Butterfly Arm must be able to pivot easily.**

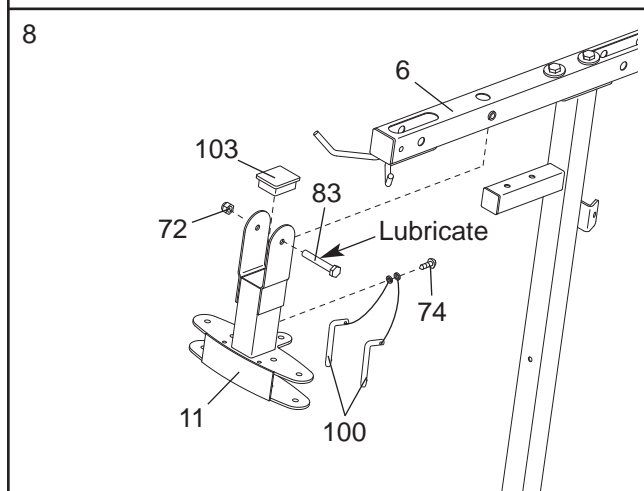

- Attach a Cable Pivot (58) to the Right Fly Arm (9) with an M10 x 50mm Bolt (85) and an M10 Nylon Locknut (72). Do not overtighten the Locknut; the Cable Pivot must be able to pivot easily.

Press a 40mm x 50mm Inner Cap (23) into the Right Fly Arm (9).

Lubricate an M10 x 83mm Button Head Bolt (86) and the flat sides of two Plastic Washers (59) with grease. Attach the Right Fly Arm (9) to the indicated side of the Butterfly Frame (11) with the Bolt, two M10 Washers (71), two Butterfly Caps (60), the two Plastic Washers, and an M10 Nylon Locknut (72). **Do not overtighten the Locknut; the Fly Arm must be able to pivot easily.**

Assemble the Left Fly Arm (10) in the same manner.

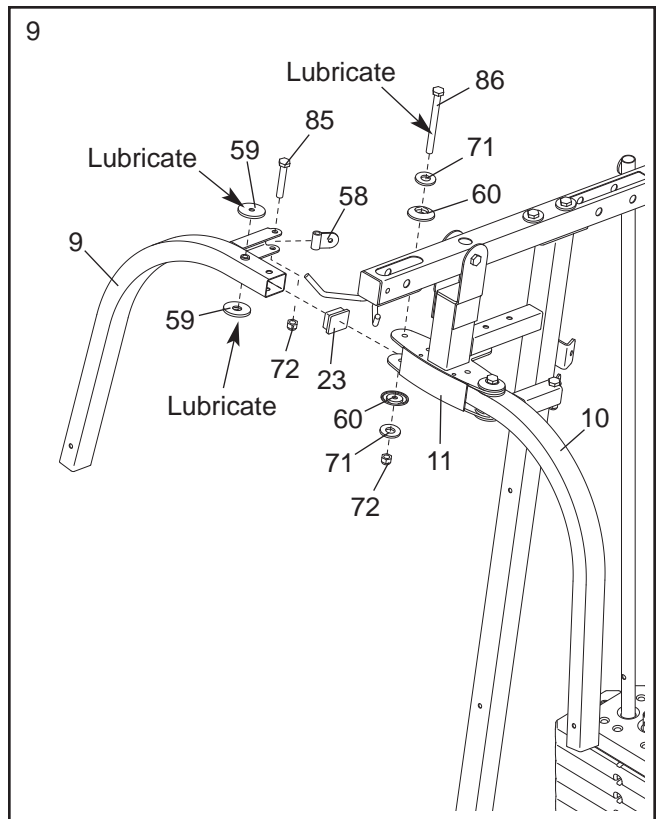

- Wet the lower end of the Right Fly Arm (9) with soapy water. Slide a Large Foam Pad (65) onto the Fly Arm.

Attach an Arm Handle (24) to the Right Fly Arm (9) with two M8 x 20mm Button Head Bolts (84).

Press a 25mm Dome Inner Cap (25) into the Right Fly Arm (9). Slide a Long Handgrip (102) onto the Fly Arm.

Slide the Large Foam Pad (65) down so that it is aligned with the bottom of the Right Fly Arm (9).

Repeat this step with the Left Fly Arm (not shown).

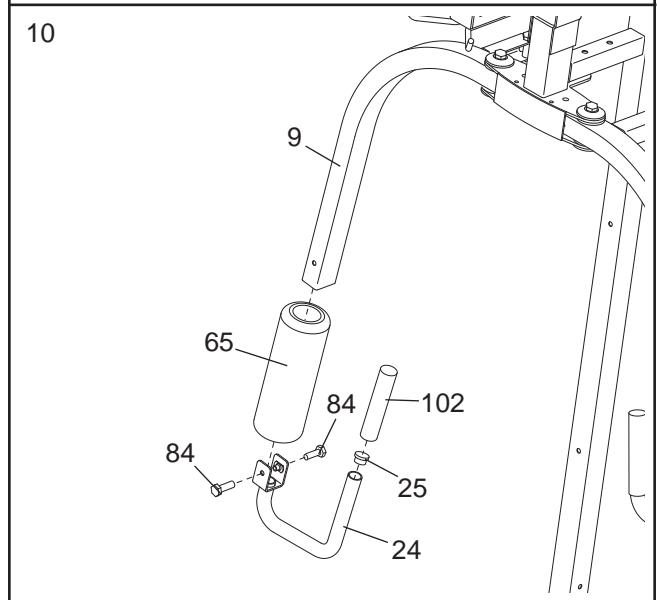

- Press two 38mm Square Inner Caps (29) into the Right and Left VKR Arms (12, 13).

Attach the Right and Left VKR Arms (12, 13) to the Rear Upright (3) with two M10 x 72mm Bolts (89) and two M10 Nylon Locknuts (72).

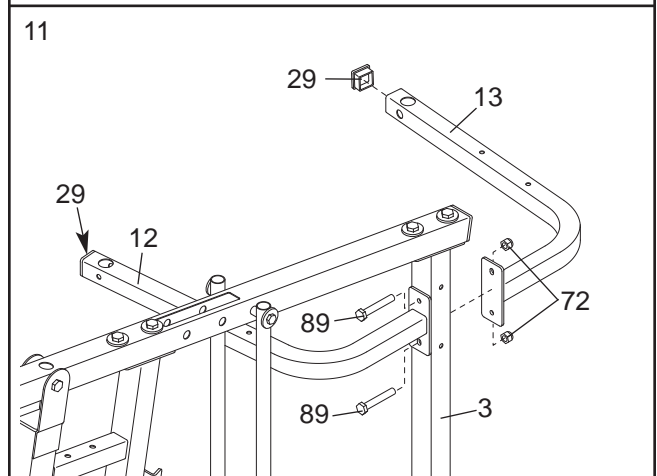

- Slide a Grip (41) onto a VKR Handle (42). Attach the VKR Handle to the Left VKR Arm (13) with an M10 x 55mm Bolt (80), two M10 Washers (71), a 7mm Spacer (43), and an M10 Nylon Locknut (72).

Press a 25mm Round Inner Cap (105) into the bottom of the VKR Handle (42).

Repeat this step with the Right VKR Arm (12).

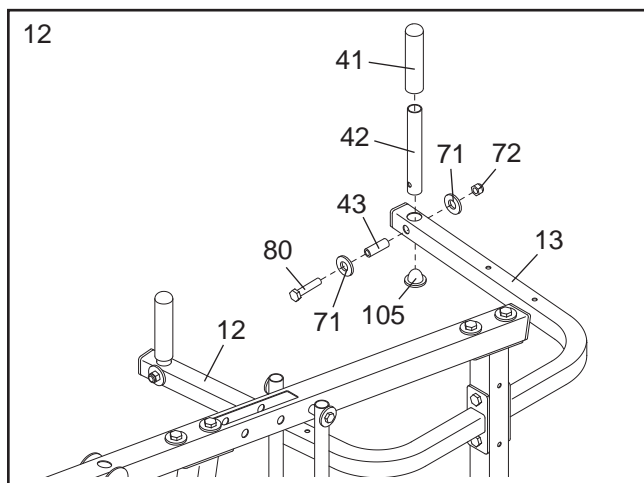

Cable Assembly

- Locate the Butterfly Cable (55).** Attach the Cable to the indicated Cable Pivot (58) with an M8 x 20mm Shoulder Bolt (93) and an M8 Nylon Locknut (73).

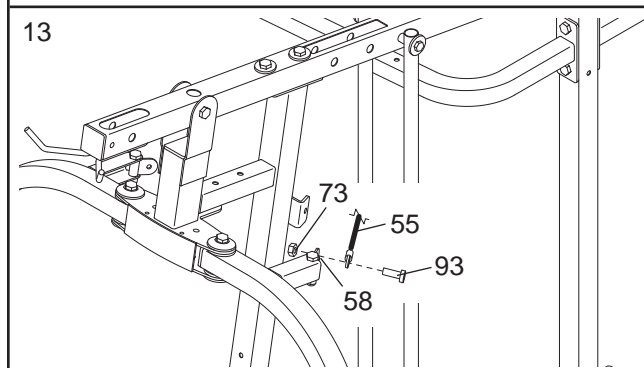

- Wrap the Butterfly Cable (55) over a "V"-pulley (47). Attach the "V"-pulley and a Cable Trap (48) to the Front Upright (4) with an M10 x 60mm Bolt (95) and an M10 Nylon Locknut (72).

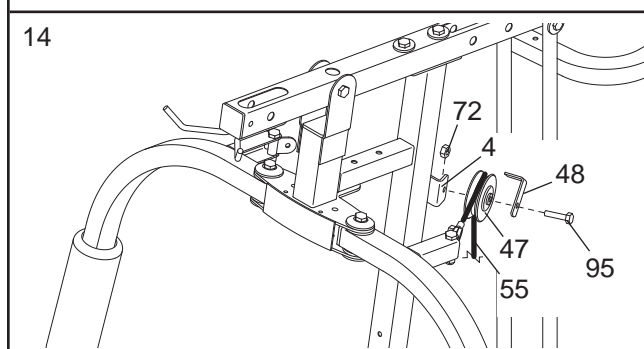

- Wrap the Butterfly Cable (55) under a 90mm Pulley (46). Attach the Pulley and two Pulley Covers (49) to the Double "U"-bracket (51) with an M10 x 53mm Bolt (88) and an M10 Nylon Locknut (72). **Make sure the small tabs on the Pulley Covers are on the top.**

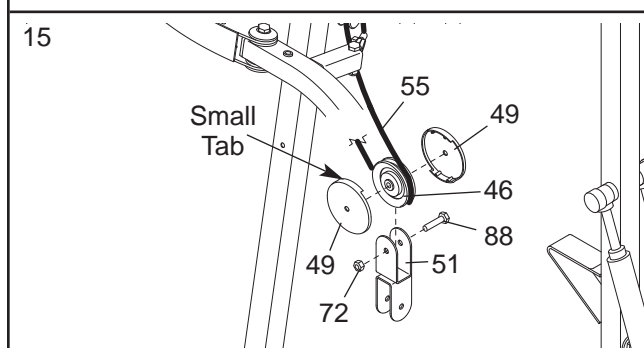

- Wrap the Butterfly Cable (55) over a "V"-pulley (47). Attach the "V"-pulley and a Cable Trap (48) to the Front Upright (4) with an M10 x 60mm Bolt (95) and an M10 Nylon Locknut (72).

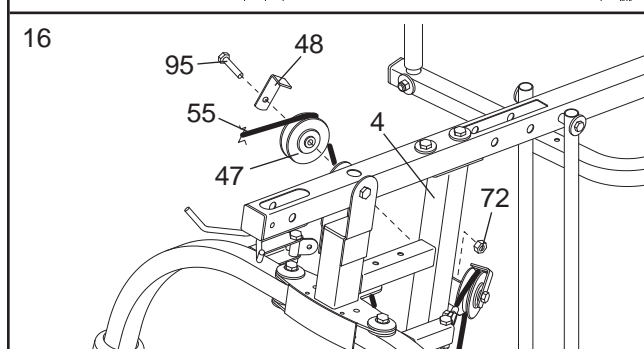

17. Attach the Butterfly Cable (55) to the indicated Cable Pivot (58) with an M8 x 20mm Shoulder Bolt (93) and an M8 Nylon Locknut (73).

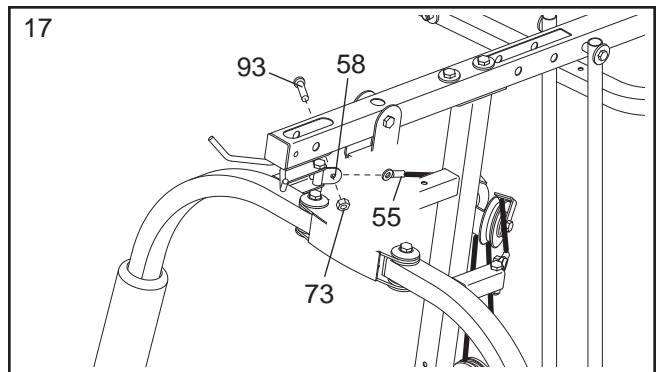

18. **Locate the Short Cable (94).** Attach the Cable to the Front Upright (4) with an M10 x 72mm Bolt (89), an M10 Washer (71), and an M10 Nylon Locknut (72).

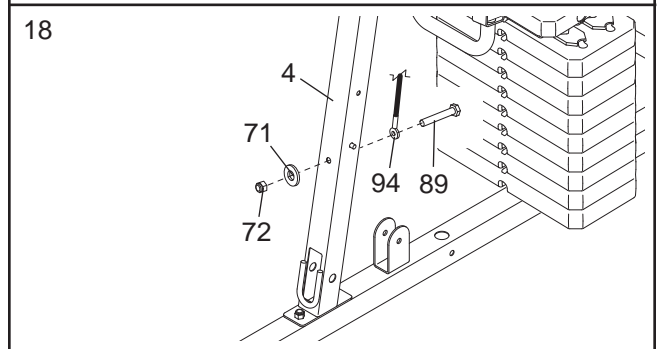

19. Wrap the Short Cable (94) under a 90mm Pulley (46). Attach the Pulley and two Pulley Covers (49) to the Double "U"-bracket (51) with an M10 x 53mm Bolt (88) and an M10 Nylon Locknut (72). **Make sure the large tabs on the Pulley Covers are on the top.**

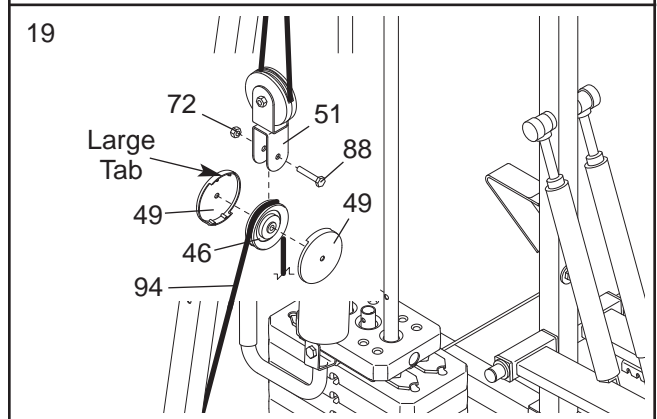

20. Attach the Short Cable (94) to the "U"-bracket (53) with an M8 Nylon Locknut (73). **Thread the Locknut onto the end of the Cable so that two threads show past the Locknut (see the inset drawing).**

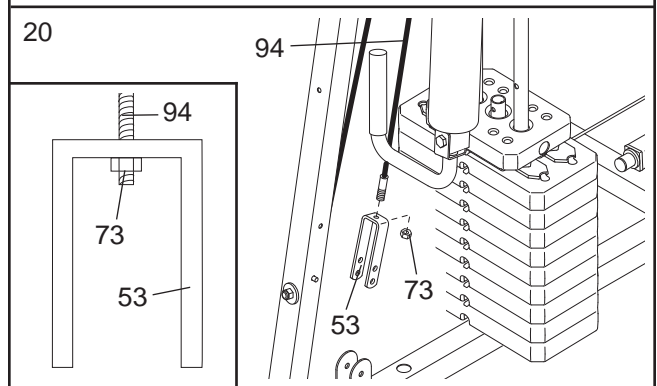

21. **Locate the High Cable (57).** Route the Cable up through the Top Frame (6) and over a 90mm Pulley (46). Attach the Pulley inside the Top Frame with an M10 x 68mm Bolt (87), two M10 Washers (71), two 12mm Spacers (54), and an M10 Nylon Locknut (72).

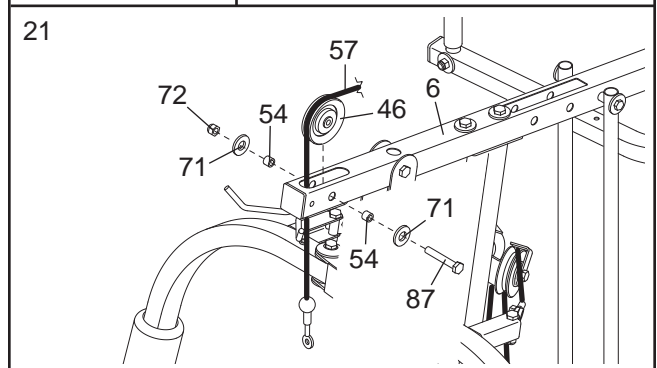

22. Route the High Cable (57) over a 90mm Pulley (46) and down through the Top Frame (6). Attach the Pulley inside the Top Frame with an M10 x 68mm Bolt (87), two M10 Washers (71), two 12mm Spacers (54), and an M10 Nylon Locknut (72).

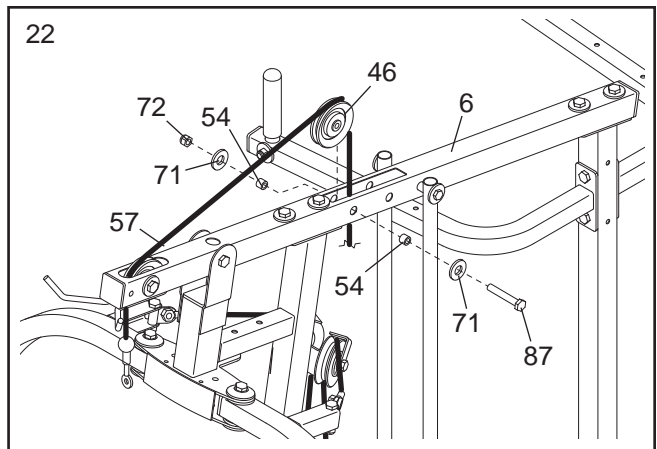

23. Route the High Cable (57) under a 90mm Pulley (46). Attach the Pulley and two Pulley Covers (49) to the upper set of holes in the two Pulley Plates (50) with an M10 x 53mm Bolt (88) and an M10 Nylon Locknut (72). **Make sure the large tabs on the Pulley Covers are on the bottom.**

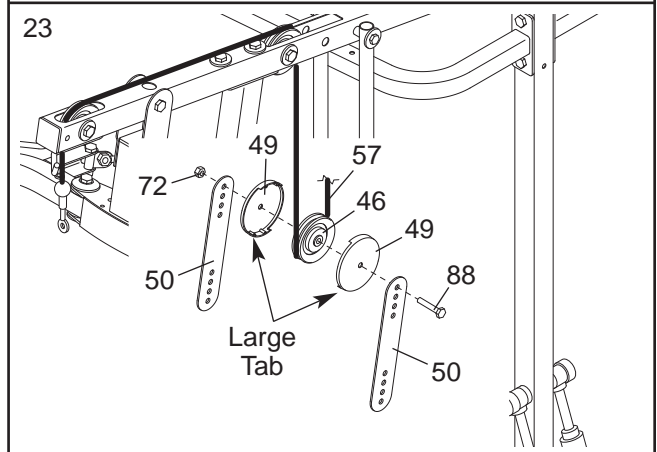

24. Route the High Cable (57) over a 90mm Pulley (46). Attach the Pulley inside the Top Frame (6) with an M10 x 68mm Bolt (87), two M10 Washers (71), two 12mm Spacers (54), and an M10 Nylon Locknut (72).

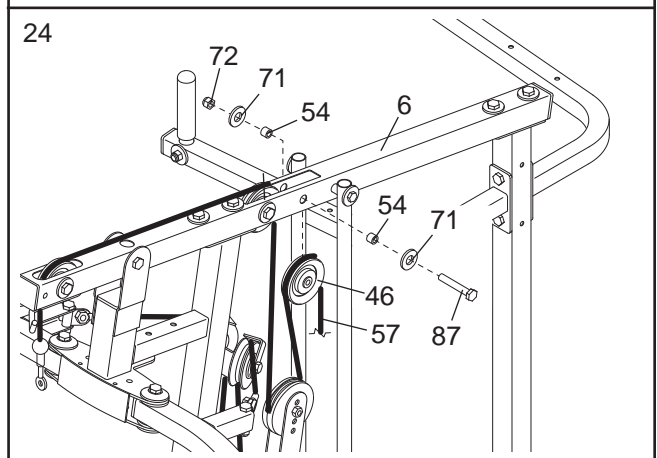

25. Attach the High Cable (57) to the Small "U"-bracket (52) with an M8 Nylon Locknut (73). **Thread the Locknut onto the end of the Cable so that two threads show past the Locknut (see the inset drawing).**

Attach the Small "U"-bracket (52) to the Weight Tube (18) with an M8 x 45mm Bolt (96) and an M8 Nylon Locknut (73). **Do not overtighten the Locknut; the Weight Tube must be able to pivot freely.**

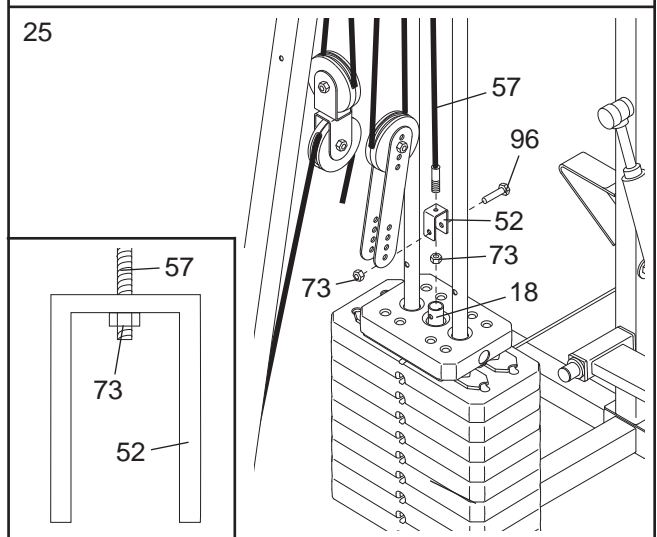

26. **Locate the Low Cable (56).** Route the Cable through the Front Upright (4) and under a 90mm Pulley (46). Attach the Pulley and two Pulley Covers (49) inside the Upright with an M10 x 68mm Bolt (87), two M10 Washers (71), two 10mm Spacers (45), and an M10 Nylon Locknut (72). **Make sure the large tabs on the Pulley Covers are in the indicated position.**

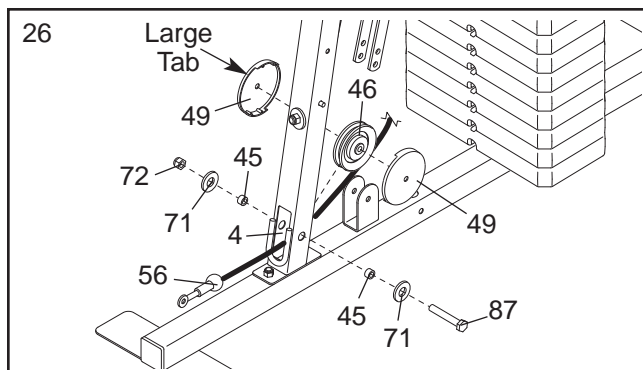

27. Route the Low Cable (56) over a 90mm Pulley (46). Attach the Pulley and two Pulley Covers (49) to the bottom set of holes in the "U"-bracket (53) with an M10 x 53mm Bolt (88) and an M10 Nylon Locknut (72). **Make sure the large tabs on the Pulley Covers are on the top.**

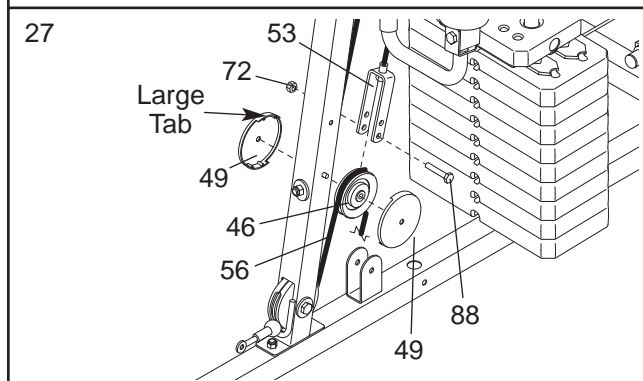

28. Wrap the Low Cable (56) under a 90mm Pulley (46). Attach the Pulley and two Pulley Covers (49) to the Base (1) with an M10 x 53mm Bolt (88) and an M10 Nylon Locknut (72). **Make sure the small tabs on the Pulley Covers are on the top.**

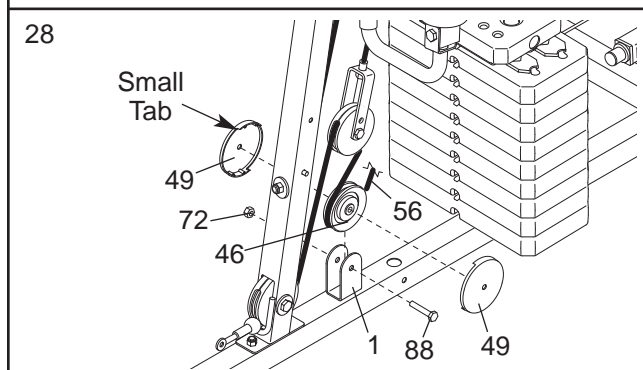

29. Route the Low Cable (56) over a 90mm Pulley (46). Attach the Pulley and two Pulley Covers (49) to the first set of holes from the bottom of the Pulley Plates (50) with an M10 x 53mm Bolt (88) and an M10 Nylon Locknut (72). **Make sure the large tabs on the Pulley Covers are on the top.**

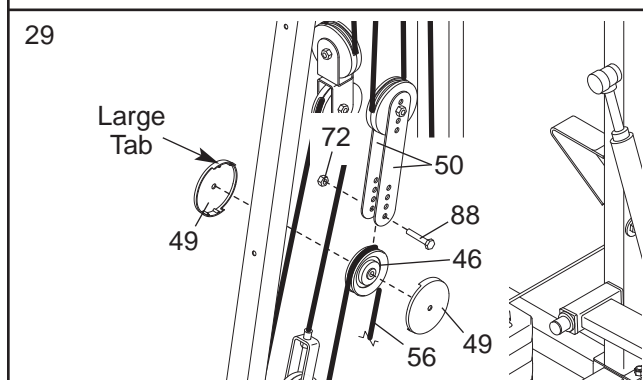

30. Attach the Low Cable (56) inside the Base (1) with an M10 x 68mm Bolt (87), two M10 Washers (71), and an M10 Nylon Locknut (72).

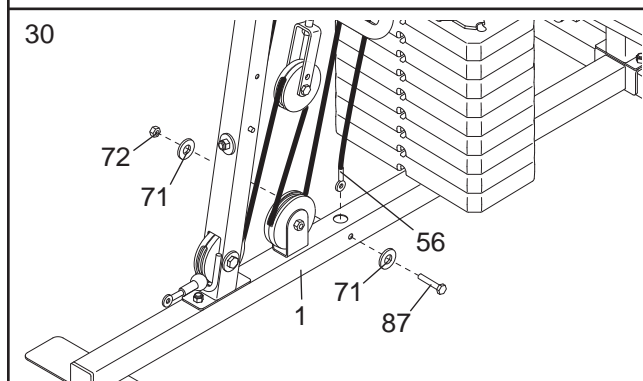

Seat Assembly

31. Attach a VKR Arm Pad (64) to the Left VKR Arm (13) with two M6 x 53mm Screws (70) and two M6 Washers (69).

Repeat this step with the Right VKR Arm (12).

32. Attach a VKR Back Pad (63) to the Rear Upright (3) with two M6 x 65mm Screws (77) and two M6 Washers (69).

33. Attach the Backrest (61) to the Front Upright (4) with two M6 x 65mm Screws (77) and two M6 Washers (69).

34. Press a 38mm Square Inner Cap (29) into the Seat Frame (7).

Attach the Seat Plate (28) to the Seat Frame (7) with an M6 x 50mm Carriage Bolt (78), an M6 Washer (69), and an M6 Nylon Locknut (90) as shown. **Do not tighten the Locknut yet.**

Attach the Seat (62) to the Seat Plate (28) with two M6 x 16mm Screws (76). Next, attach the Seat to the Seat Frame (7) with an M6 x 53mm Screw (70) and an M6 Washer (69).

Tighten the M6 Nylon Locknut (90).

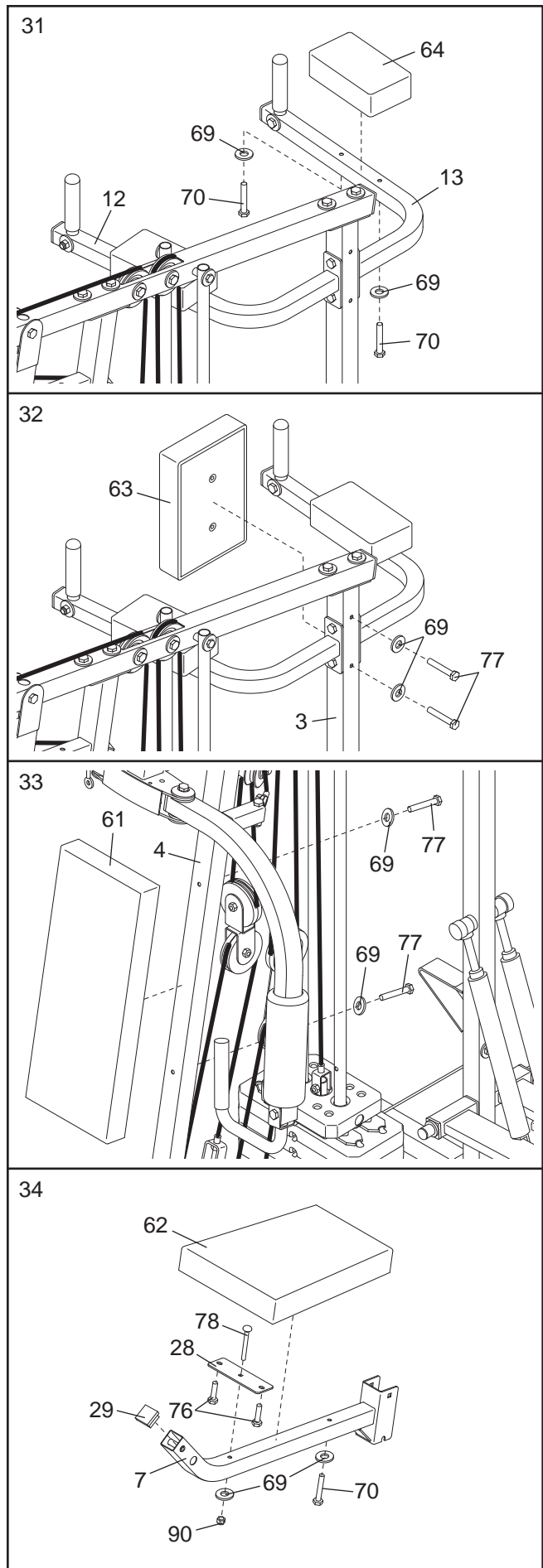

35. Press a 38mm Square Inner Cap (29) into the Leg Lever (8).

Attach the M10 x 63mm Eyebolt (97) to the Leg Lever (8) with an M10 Large Washer (108) and an M10 Nylon Locknut (72).

Lubricate an M8 x 57mm Bolt (79) with grease. Attach the Leg Lever (8) to the Seat Frame (7) with the Bolt and an M8 Nylon Locknut (73). **Do not overtighten the Locknut; the Leg Lever must be able to pivot easily.**

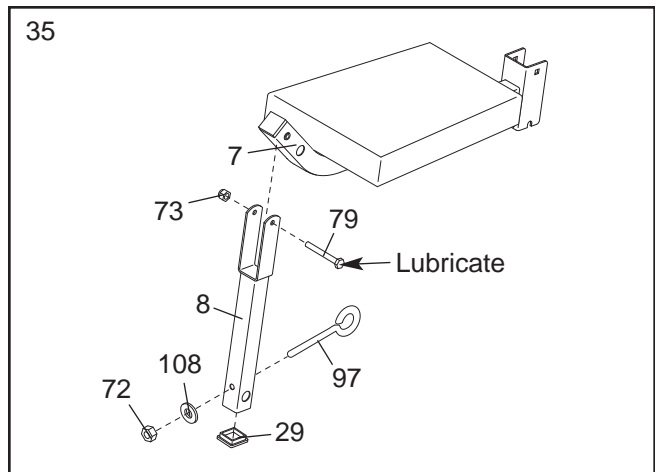

36. Press two 19mm Round Inner Caps (27) into a Pad Tube (26). Slide the Pad Tube into the hole in the Leg Lever (8). Slide two Small Foam Pads (66) onto the Pad Tube.

Assemble the other Pad Tube (26) to the Seat Frame (7) in the same manner.

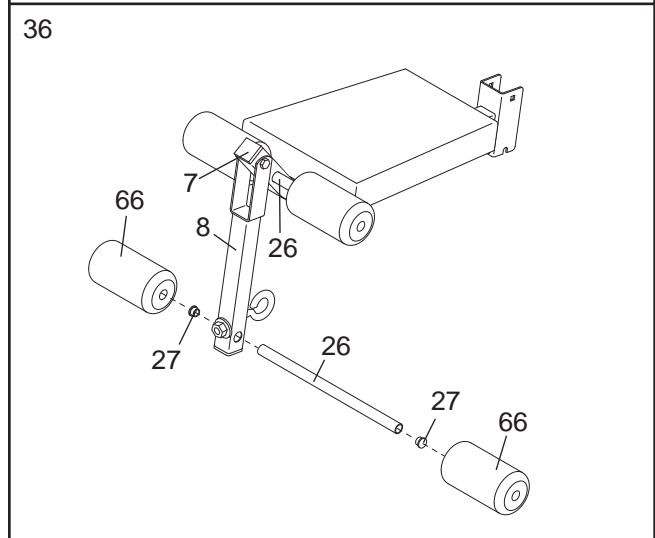

37. Set the Seat Frame (7) on the pin on the Front Upright (4). Secure the Seat Frame with an M8 x 67mm Carriage Bolt (82) and the M8 Knob (106).

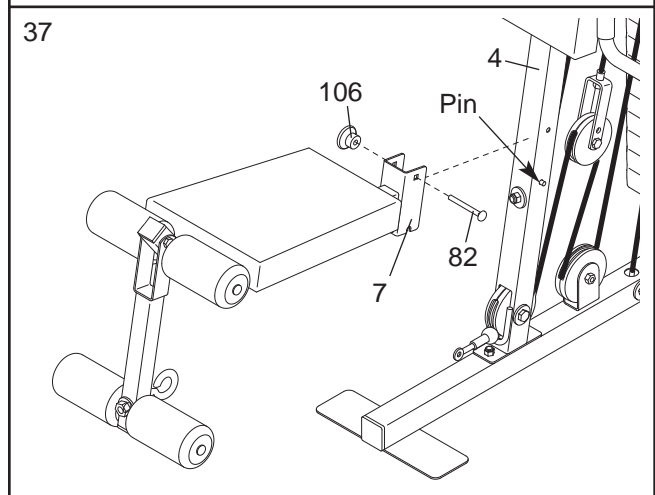

38. Make sure that all parts are properly tightened. The use of all remaining parts will be explained in ADJUSTMENT, beginning on the following page. Before using the weight system, pull each cable a few times to make sure that the cables move smoothly over the pulleys. If one of the cables does not move smoothly, locate and correct the problem before using the weight system. **IMPORTANT: If the cables are not properly routed, they may be damaged when heavy weight is used. See the CABLE DIAGRAM on page 20 of this manual.**

ADJUSTMENT

The instructions below describe how each part of the weight system can be adjusted. **IMPORTANT: When attaching the lat bar or handle, make sure that the accessories are in the correct starting position for the exercise to be performed. If there is any slack in the cable or chain as an exercise is performed, the effectiveness of the exercise will be reduced.**

CHANGING THE WEIGHT SETTING

To change the weight setting, insert the Weight Pin (20) under one of the Weights (16). Make sure to insert the Weight Pin until the bent end of the Weight Pin is touching the Weights, and turn the bent end downward. The weight setting can be changed from 12.5 pounds to 125 pounds, in increments of 12.5 pounds. **Important: Due to the cables and pulleys, the actual amount of resistance at each exercise station will vary from the weight setting. Refer to the WEIGHT RESISTANCE CHART on page 18 to find the actual amount of resistance at each station.** Note: 1 kg = 2,2 pounds.

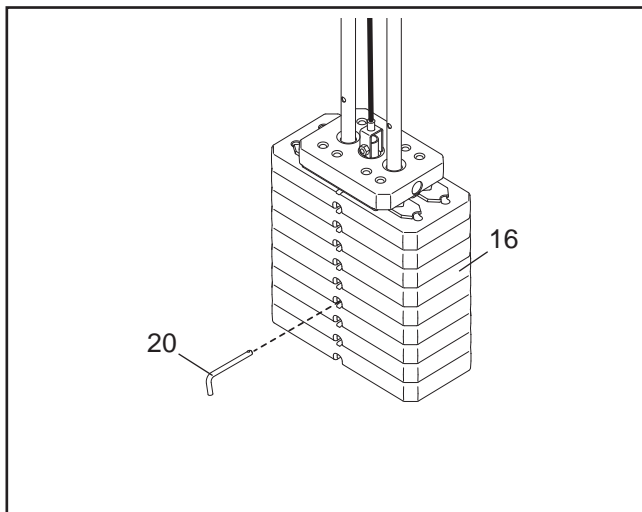

LOCKING THE WEIGHT STACK

To prevent unauthorised use of the weight system, insert the Locking Bar (21) into the indicated hole in one of the Weight Guides (5). Secure the Locking Bar with the Lock (22).

Remove the Lock (22) and Locking Bar (21) to use the weight system again.

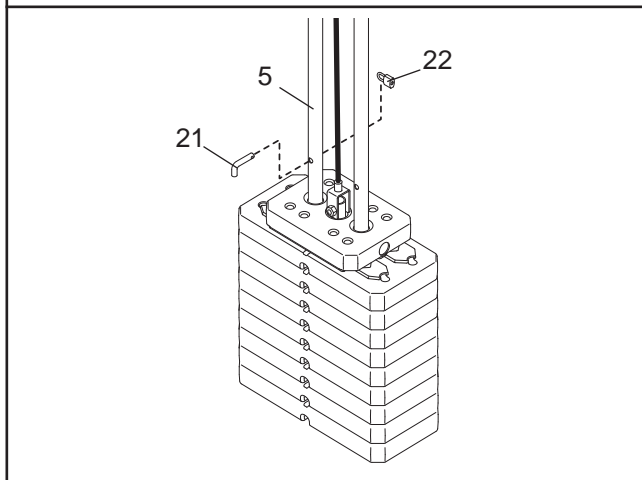

ATTACHING THE ACCESSORIES TO A PULLEY STATION

Attach the Lat Bar (101) to the High Cable (57) with a Cable Clip (68). For some exercises, the Chain (99) should be attached between the Lat Bar and the High Cable with two Cable Clips. **Adjust the length of the Chain between the Lat Bar and the High Cable so that the Lat Bar is in the correct starting position for the exercise to be performed.**

The Handle (not shown) can be attached in the same manner. The accessories can be attached to the Low Cable (not shown) in the same manner.

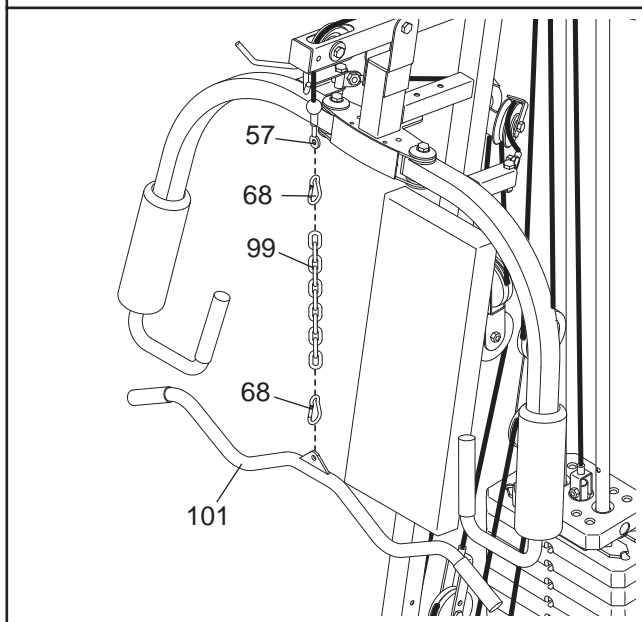

CONVERTING THE BUTTERFLY ARMS

To use the Fly Arms (9, 10) as butterfly arms, insert the “L”-pins (100) into the butterfly holes in the Front Upright (4) and the tab on the back of the Butterfly Frame (11).

To use the Fly Arms (9, 10) as press arms, insert the “L”-pins (100) into the press holes in the Butterfly Frame (11).

Make sure that the “L”-pins (100) are fully inserted into the same set of holes before performing any exercises.

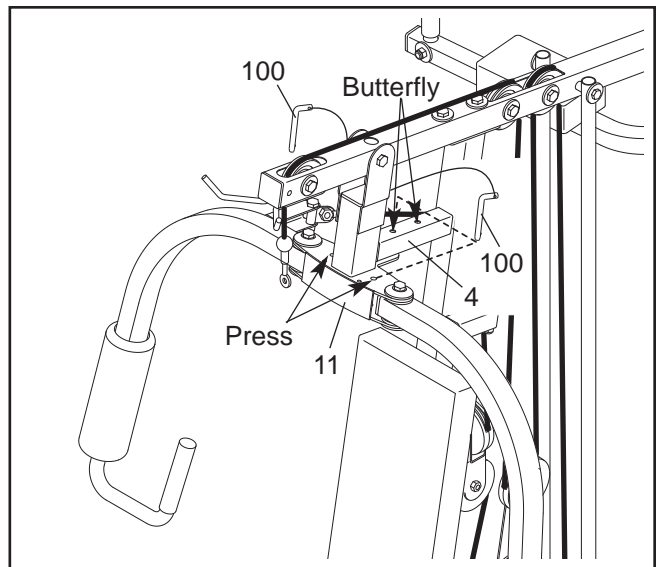

ATTACHING THE SEAT

Set the Seat Frame (7) on the pin on the Front Upright (4). Secure the Seat Frame with an M8 x 67mm Carriage Bolt (82) and the M8 Knob (106).

For some exercises, the Seat (7) must be removed. First, make sure that the chain is not attached to the leg lever (see ATTACHING THE LEG LEVER, below). Next, remove the M8 Knob (106) and M8 x 67mm Carriage Bolt (82) from the Seat Frame. Lift the Seat Frame off the Front Upright (4).

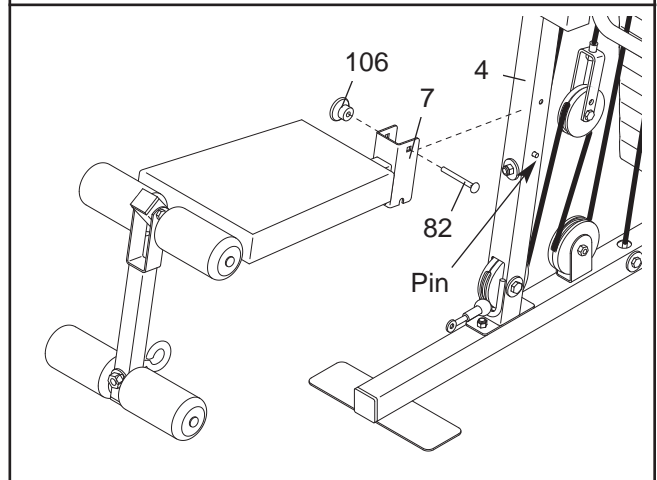

ATTACHING THE LEG LEVER

To use the Leg Lever (8), first attach the seat to the weight system (see ATTACHING THE SEAT, above). Next attach the Low Cable (56) to the M10 x 63mm Eyebolt (97) with the Chain (99) and two Cable Clips (68).

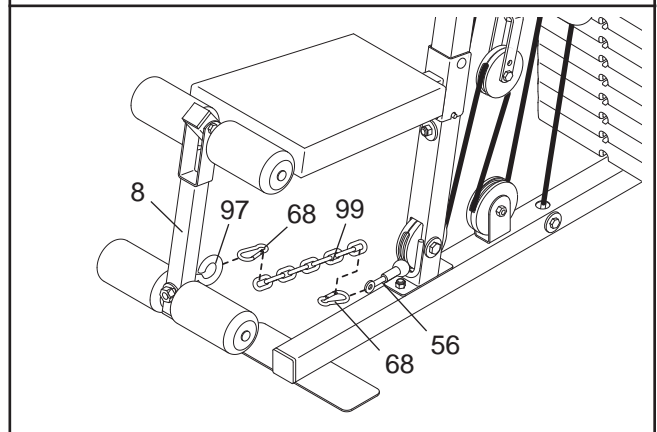

CHANGING THE STEPPING RESISTANCE

To change the stepping resistance, lift the Right and Left Pedals (14, 15) off the hooks at the lower ends of the Resistance Cylinders (37). Move the hooks to different slots under the Pedals. **Make sure that the hooks are fully inserted into the slots in the same position under both Pedals.** The farther the hooks are moved from the Rear Upright (3), the greater the resistance will be.

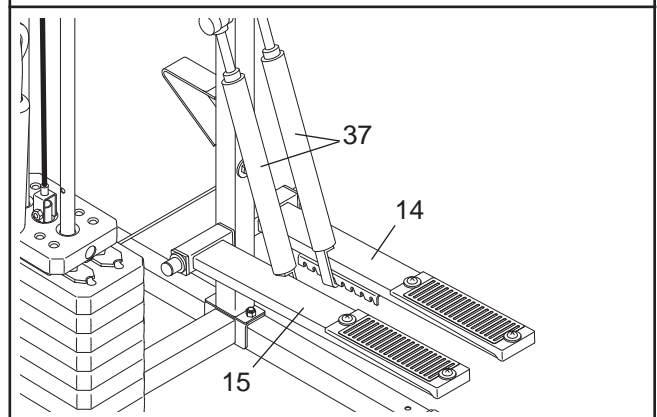

⚠ WARNING: The Resistance Cylinders (37) become very hot during use. Allow the Resistance Cylinders to cool before touching them.

WEIGHT RESISTANCE CHART

The chart below shows the approximate weight resistance at each exercise station. "Top" refers to the 6 lb. top weight. The other numbers refer to the 12.5 lb. weight plates. Weight resistance shown for the butterfly arm station is for each butterfly arm. **Note: The actual resistance at each station may vary due to differences in individual weight plates as well as friction between the cables, pulleys, and weight guides.**

WEIGHT	HIGH PULLEY (lbs.)	PRESS ARM (lbs.)	BUTTERFLY ARM (lbs.)	LEG LEVER (lbs.)	LOW PULLEY (lbs.)
Top	13	25	18	13	15
1	31	44	33	26	34
2	47	67	52	40	48
3	64	81	62	53	64
4	77	101	76	65	78
5	87	118	86	75	90
6	106	135	98	91	103
7	128	158	114	106	120
8	138	183	125	117	137
9	154	197	139	134	153

Note: 1 kg = 2,2 pounds.

TROUBLESHOOTING

Make sure all parts are properly tightened each time the weight system is used. Replace any worn parts immediately. The weight system can be cleaned using a damp cloth and mild non-abrasive detergent. Do not use solvents.

TIGHTENING THE CABLES

Woven cable, the type of cable used on the weight system, can stretch slightly when it is first used. If there is slack in the cables before resistance is felt, the cables should be tightened. Slack can be removed from the cables in several different ways.

TIGHTENING THE PULLEY PLATES

Slack can be removed by moving a 90mm Pulley (not shown) and the Pulley Covers (49) to a set of holes closer to the centre of the two Pulley Plates (50). Remove the M10 Nylon Locknut (72) and the M10 x 53mm Bolt (88) from the Pulley Covers, the Pulley, and the Pulley Plates. Re-attach the Pulley and the Pulley Covers to the new set of holes in the Pulley Plates with the Bolt and Locknut.

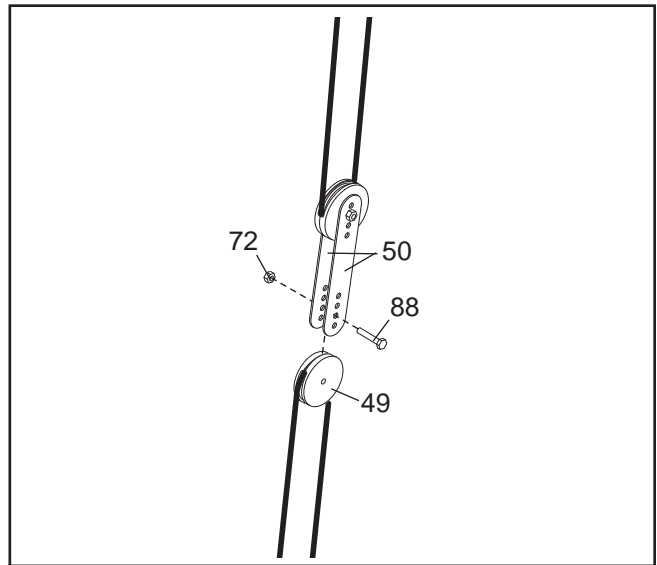

TIGHTENING THE “U”-BRACKET

Slack can be removed by moving the 90mm Pulley (not shown) and the Pulley Covers (49) to the upper set of holes in the “U”-bracket (53). Remove the M10 Nylon Locknut (72) and the M10 x 53mm Bolt (88) from the Pulley Covers, the Pulley, and the “U”-bracket. Re-attach the Pulley and the Pulley Covers to the new set of holes in the “U”-bracket with the Bolt and Locknut.

Slack can also be removed from the Short Cable (94) by tightening the M8 Nylon Locknut (73) a couple of turns onto the Short Cable.

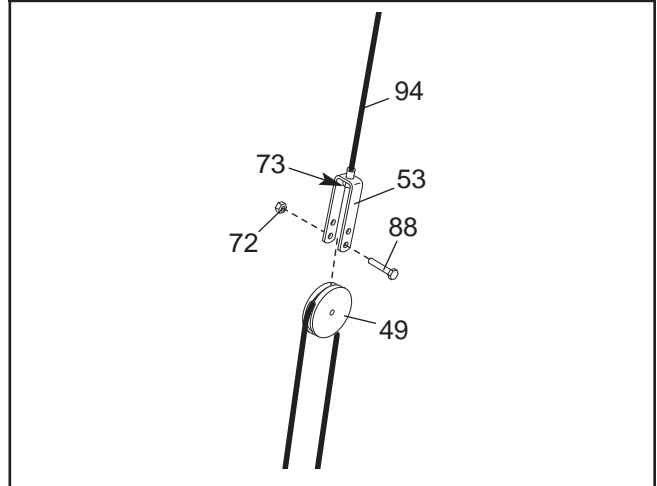

CABLE DIAGRAM

The cable diagram below shows the proper routing of the Butterfly Cable (55), the Low Cable (56), the High Cable (57), and the Short Cable (94). Use the diagrams to make sure that the cables and the cable traps have been assembled correctly. If the cables have not been correctly routed, the weight system will not function properly and damage may occur. The numbers show the correct route for each cable. **Make sure that the cable traps do not touch or bind the cables.**

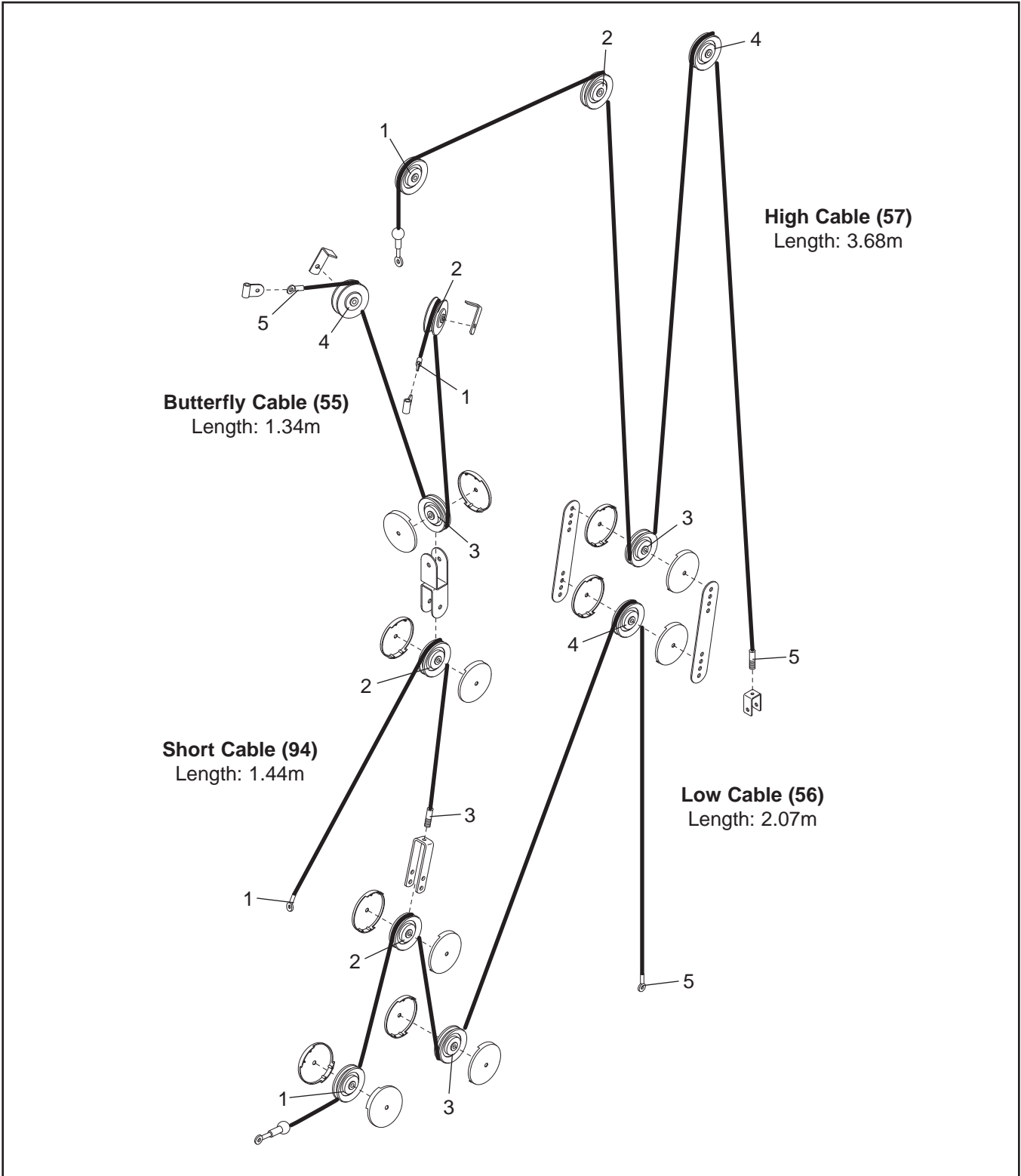

EXERCISE GUIDELINES

THE FOUR BASIC TYPES OF WORKOUTS

MUSCLE BUILDING

To increase the size and strength of your muscles, push them close to their maximum capacity. Your muscles will continually adapt and grow as you progressively increase the intensity of your exercise. You can adjust the intensity level of an individual exercise in two ways:

- by changing the amount of resistance used
- by changing the number of repetitions or sets performed. (A “repetition” is one complete cycle of an exercise, such as one sit-up. A “set” is a series of repetitions.)

The proper amount of resistance for each exercise depends upon the individual user. You must gauge your limits and select the amount of resistance that is right for you. Begin with 3 sets of 8 repetitions for each exercise you perform. Rest for 3 minutes after each set. When you can complete 3 sets of 12 repetitions without difficulty, increase the amount of resistance.

TONING

You can tone your muscles by pushing them to a moderate percentage of their capacity. Select a moderate amount of resistance and increase the number of repetitions in each set. Complete as many sets of 15 to 20 repetitions as possible without discomfort. Rest for 1 minute after each set. Work your muscles by completing more sets rather than by using high amounts of resistance.

WEIGHT LOSS

To lose weight, use a low amount of resistance and increase the number of repetitions in each set. Exercise for 20 to 30 minutes, resting for a maximum of 30 seconds between sets.

CROSS TRAINING

Cross training is an efficient way to get a complete and well-balanced fitness program. An example of a balanced program is:

- Plan strength training workouts on Monday, Wednesday, and Friday.
- Plan 20 to 30 minutes of aerobic exercise, such as running on a treadmill or riding on an elliptical or exercise bike, on Tuesday and Thursday.
- Rest from both strength training and aerobic exercise for at least one full day each week to give your body time to regenerate.

The combination of strength training and aerobic exercise will reshape and strengthen your body, plus develop your heart and lungs.

PERSONALISING YOUR EXERCISE PROGRAM

Determining the exact length of time for each workout, as well as the number of repetitions or sets completed, is an individual matter. It is important to avoid overdoing it during the first few months of your exercise program. You should progress at your own pace and be sensitive to your body’s signals. If you experience pain or dizziness at any time whilst exercising, stop immediately and begin cooling down. Find out what is wrong before continuing. Remember that adequate rest and a proper diet are important factors in any exercise program.

WARMING UP

Begin each workout with 5 to 10 minutes of stretching and light exercise to warm up. Warming up prepares your body for more strenuous exercise by increasing circulation, raising your body temperature and delivering more oxygen to your muscles.

WORKING OUT

Each workout should include 6 to 10 different exercises. Select exercises for every major muscle group, emphasising areas that you want to develop most. To give balance and variety to your workouts, vary the exercises from session to session.

Schedule your workouts for the time of day when your energy level is the highest. Each workout should be followed by at least one day of rest. Once you find the schedule that is right for you, stick with it.

EXERCISE FORM

Maintaining proper form is an essential part of an effective exercise program. This requires moving through the full range of motion for each exercise, and moving only the appropriate parts of the body. Exercising in an uncontrolled manner will leave you feeling exhausted. On the exercise guide accompanying this manual you will find photographs showing the correct form for several exercises, and a list of the muscles affected. Refer to the muscle chart on the next page to find the names of the muscles.

The repetitions in each set should be performed smoothly and without pausing. The exertion stage of each repetition should last about half as long as the return stage. Proper breathing is important. Exhale during the exertion stage of each repetition and inhale during the return stroke. Never hold your breath.

Rest for a short period of time after each set. The ideal resting periods are:

- Rest for three minutes after each set for a muscle building workout.
- Rest for one minute after each set for a toning workout.
- Rest for 30 seconds after each set for a weight loss workout.

Plan to spend the first couple of weeks familiarising yourself with the equipment and learning the proper form for each exercise.

COOLING DOWN

End each workout with 5 to 10 minutes of stretching. Include stretches for both your arms and legs. Move

slowly as you stretch and do not bounce. Ease into each stretch gradually and go only as far as you can without strain. Stretching at the end of each workout is an effective way to increase flexibility.

STAYING MOTIVATED

For motivation, keep a record of each workout. The chart on page 23 of this manual can be photocopied and used to schedule and record your workouts. List the date, the exercises performed, the resistance used, and the numbers of sets and repetitions completed. Record your weight and key body measurements at the end of every month. Remember, the key to achieving the greatest results is to make exercise a regular and enjoyable part of your everyday life.

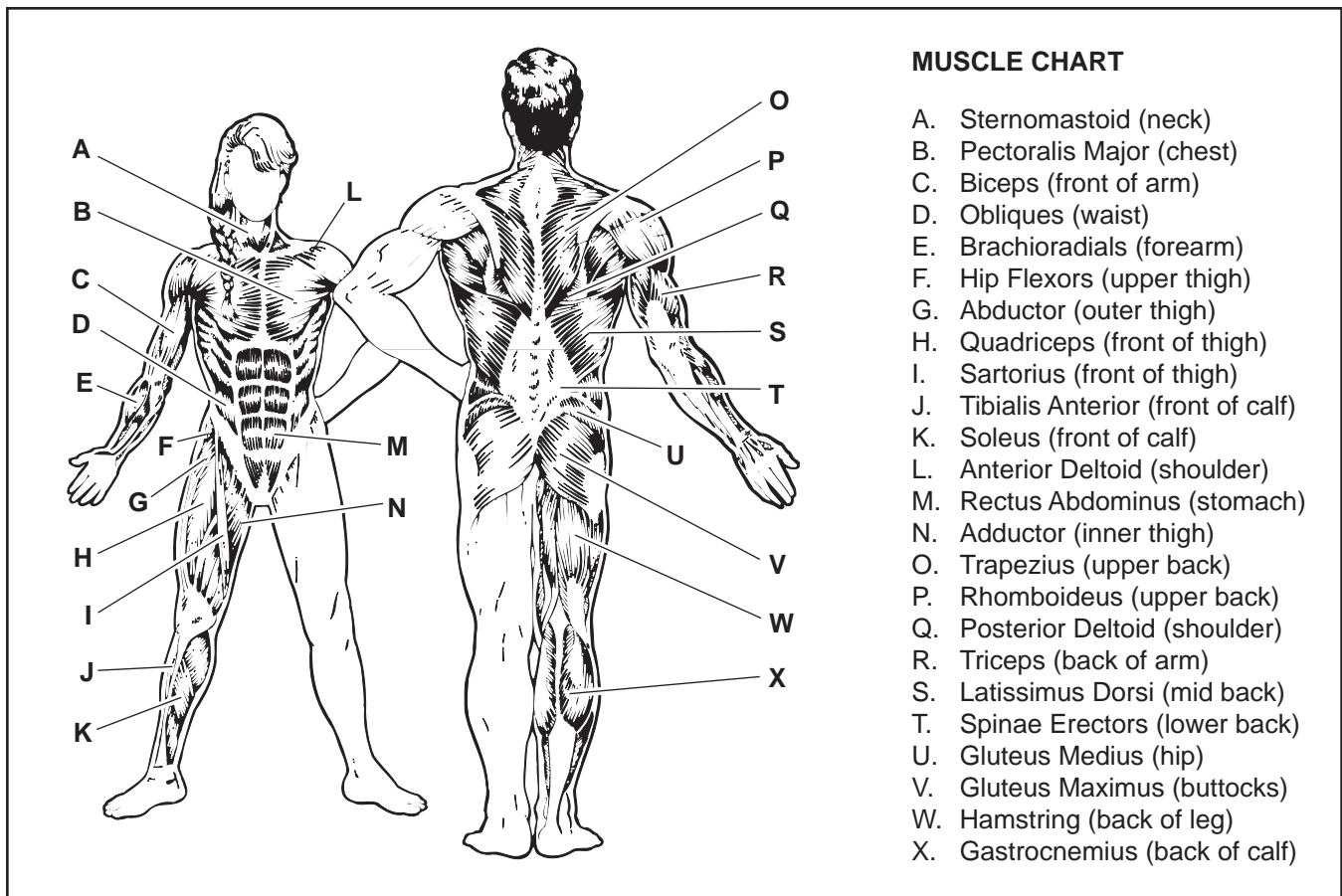

MONDAY	EXERCISE	WEIGHT	SETS	REPS
Date: _____ / _____ / _____				

TUESDAY AEROBIC EXERCISE

Date: _____ / _____ / _____

WEDNESDAY	EXERCISE	WEIGHT	SETS	REPS
Date: _____ / _____ / _____				

THURSDAY AEROBIC EXERCISE

Date: _____ / _____ / _____

FRIDAY	EXERCISE	WEIGHT	SETS	REPS
Date: _____ / _____ / _____				

Make photocopies of this page for scheduling and recording your workouts.

ORDERING REPLACEMENT PARTS

To order replacement parts, contact the ICON Health & Fitness, Ltd. office, or write:

ICON Health & Fitness, Ltd.
Unit 4
Revie Road Industrial Estate
Revie Road
Beeston
Leeds, LS118JG
UK

Tel:

08457 089 009

Outside the UK: 0 (444) 113 387 7133

Fax: 0 (444) 113 387 7125

Please provide the following information when ordering replacement parts:

- the MODEL NUMBER of the product (WEEVSY20230)
- the NAME of the product (WEIDER® 9025 weight system)
- the SERIAL NUMBER of the product (see the front cover of this manual)
- the KEY NUMBER and DESCRIPTION of the part(s) (see the PART LIST and EXPLODED DRAWING in the centre of this manual)

WEIDER is a registered trademark of ICON Health & Fitness, Inc.

**REMOVE THIS PART LIST/EXPLODED DRAWING
FROM THE MANUAL.**

SAVE THIS PART LIST/EXPLODED DRAWING FOR FUTURE REFERENCE

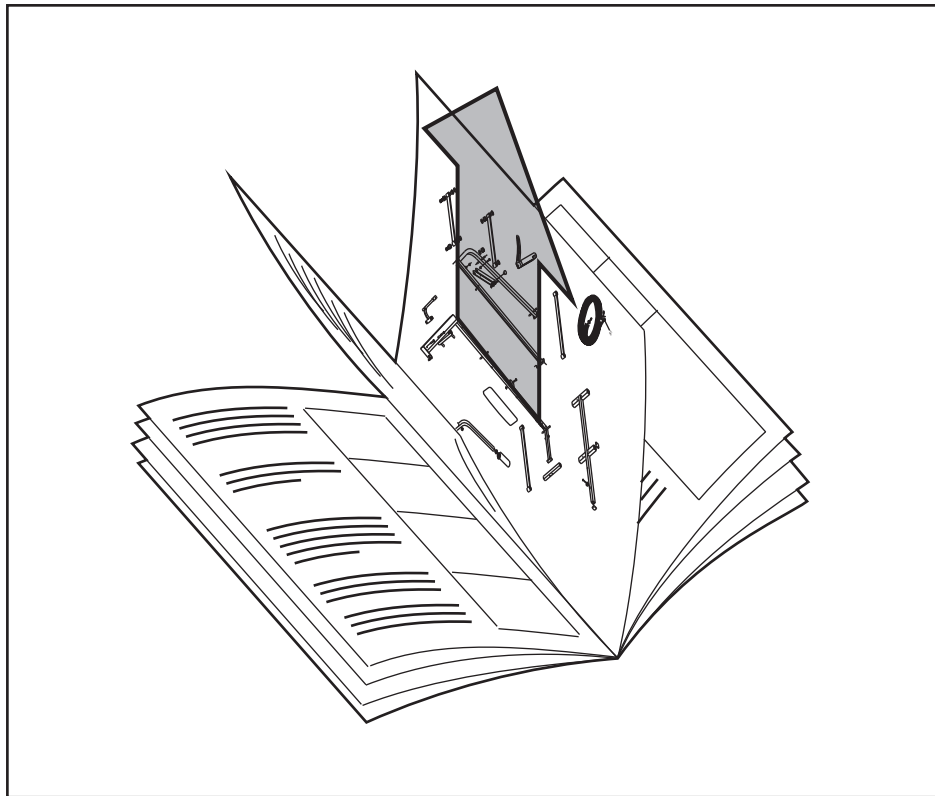

Note: Specifications are subject to change without notice. See the back cover of the user's manual for information about ordering replacement parts.

PART LIST—Model No. WEEVSY20230

R1103A

Key No.	Qty.	Description	Key No.	Qty.	Description
1	1	Base	57	1	High Cable
2	1	Stabiliser	58	2	Cable Pivot
3	1	Rear Upright	59	4	Plastic Washer
4	1	Front Upright	60	4	Butterfly Cap
5	2	Weight Guide	61	1	Backrest
6	1	Top Frame	62	1	Seat
7	1	Seat Frame	63	1	VKR Back Pad
8	1	Leg Lever	64	2	VKR Arm Pad
9	1	Right Fly Arm	65	2	Large Foam Pad
10	1	Left Fly Arm	66	4	Small Foam Pad
11	1	Butterfly Frame	67	1	Handle
12	1	Right VKR Arm	68	3	Cable Clip
13	1	Left VKR Arm	69	10	M6 Washer
14	1	Right Pedal	70	5	M6 x 53mm Screw
15	1	Left Pedal	71	26	M10 Washer
16	9	Weight	72	33	M10 Nylon Locknut
17	1	Weight Tube Bumper	73	8	M8 Nylon Locknut
18	1	Weight Tube	74	9	M4 x 16mm Self-tapping Screw
19	1	Top Weight	75	8	M4 Washer
20	1	Weight Pin	76	2	M6 x 16mm Screw
21	1	Locking Bar	77	4	M6 x 65mm Screw
22	1	Lock	78	1	M6 x 50mm Carriage Bolt
23	2	40mm x 50mm Inner Cap	79	1	M8 x 57mm Bolt
24	2	Arm Handle	80	2	M10 x 55mm Bolt
25	2	25mm Dome Inner Cap	81	2	M10 x 65mm Carriage Bolt
26	2	Pad Tube	82	3	M8 x 67mm Carriage Bolt
27	4	19mm Round Inner Cap	83	1	M10 x 80mm Bolt
28	1	Seat Plate	84	4	M8 x 20mm Button Head Bolt
29	5	38mm Square Inner Cap	85	2	M10 x 50mm Bolt
30	2	25mm Round Outer Cap	86	2	M10 x 83mm Button Head Bolt
31	3	50mm Square Inner Cap	87	9	M10 x 68mm Bolt
32	2	Base Cap	88	6	M10 x 53mm Bolt
33	1	Support Bracket	89	4	M10 x 72mm Bolt
34	1	Grip Tape	90	1	M6 Nylon Locknut
35	4	38mm Square Bushing	91	1	M10 x 153mm Bolt
36	2	Pedal Cover	92	1	M10 Star Washer
37	2	Resistance Cylinder	93	2	M8 x 20mm Shoulder Bolt
38	2	16mm Round Outer Cap	94	1	Short Cable
39	2	16mm Retainer	95	2	M10 x 60mm Bolt
40	2	16mm Round Bushing	96	1	M8 x 45mm Bolt
41	4	Grip	97	1	M10 x 63mm Eyebolt
42	2	VKR Handle	98	2	25mm Retainer
43	2	7mm Spacer	99	1	Chain
44	2	Weight Bumper	100	2	"L"-pin
45	2	10mm Spacer	101	1	Lat Bar
46	10	90mm Pulley	102	2	Long Handgrip
47	2	"V"-pulley	103	1	50mm x 70mm Inner Cap
48	2	Cable Trap	104	1	Ankle Strap
49	14	Pulley Cover	105	2	25mm Round Inner Cap
50	2	Pulley Plate	106	1	M8 Knob
51	1	Double "U"-bracket	107	1	M10 x 67mm Carriage Bolt
52	1	Small "U"-bracket	108	1	M10 Large Washer
53	1	"U"-bracket	109	2	18mm Spacer
54	6	12mm Spacer	#	1	User's Manual
55	1	Butterfly Cable	#	1	Exercise Guide
56	1	Low Cable	#	2	Grease Pack

Note: "#" indicates a non-illustrated part. Specifications are subject to change without notice. See the back cover of the user's manual for information about ordering replacement parts.

EXPLODED DRAWING—Model No. WEEVSY20230

R1103A

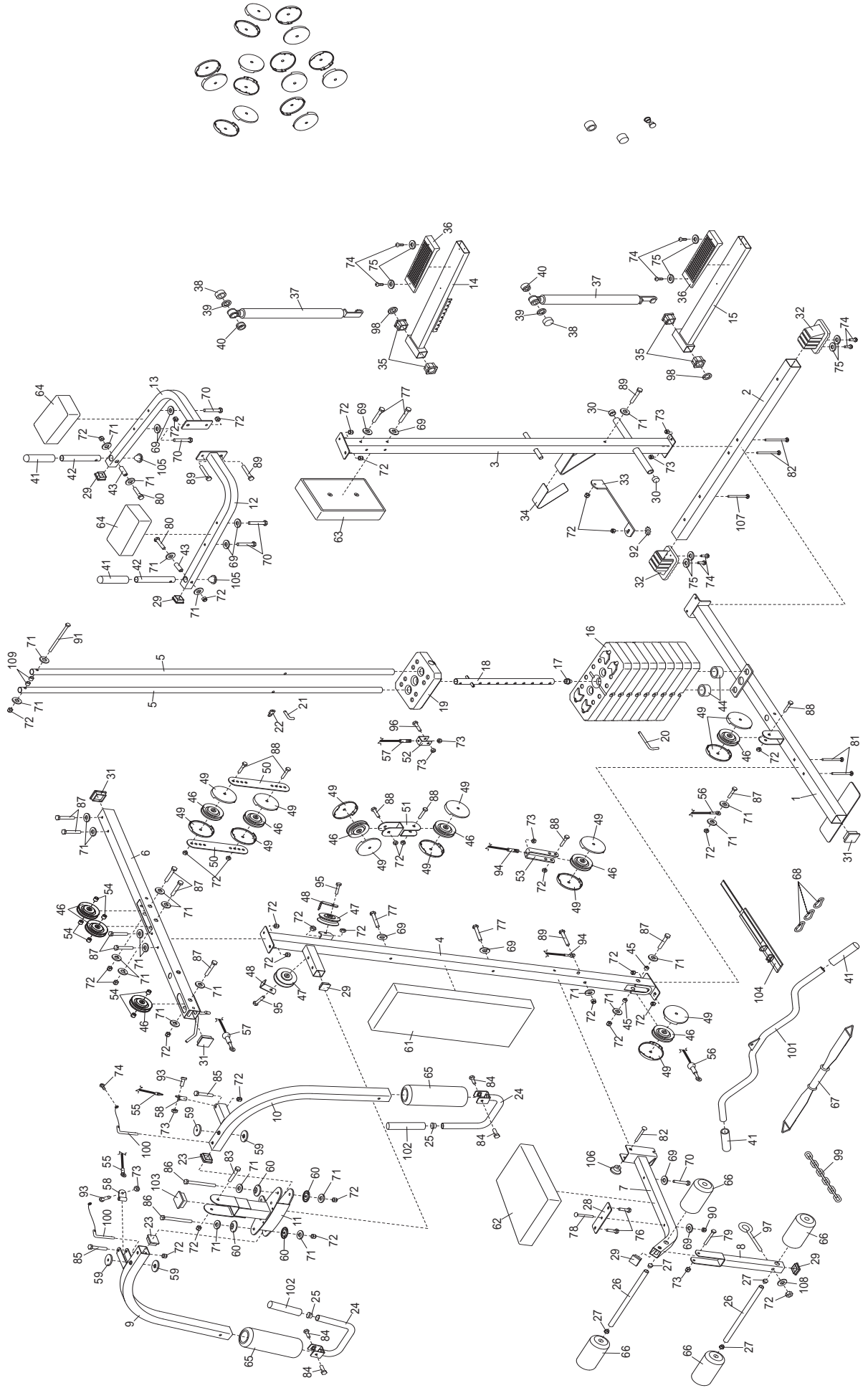

REMOVE THIS PART IDENTIFICATION CHART FROM THE MANUAL. SAVE THIS PART IDENTIFICATION CHART FOR FUTURE REFERENCE.

This chart is provided to help you identify the small parts used in assembly. The number in parenthesis below each part refers to the key number of the part from the PART LIST in the centre of this manual. **Important:** Some parts may have been pre-assembled for shipping purposes. If you cannot find a part in the parts bags, check to see if it has been pre-assembled.

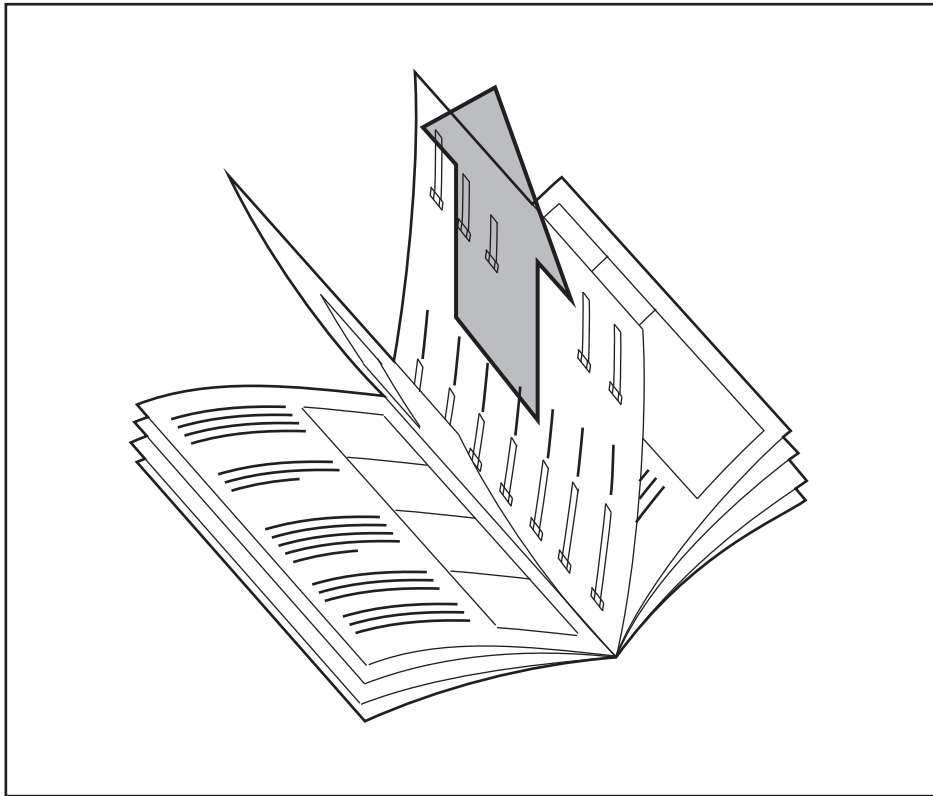

Note: Assembly is divided into four stages: 1) frame assembly, 2) arm assembly, 3) cable assembly, and 4) seat assembly. The hardware for each stage is packaged separately. **WAIT UNTIL YOU BEGIN EACH ASSEMBLY STAGE TO OPEN THE PARTS BAG LABELLED FOR THAT ASSEMBLY STAGE.**

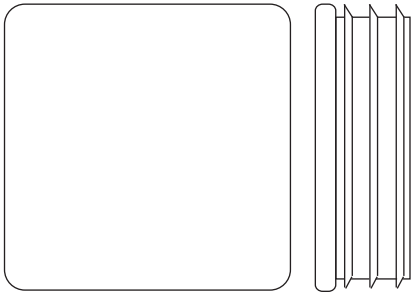

38mm Square Inner Cap (29)

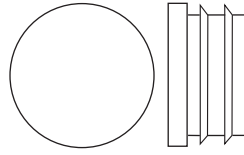

19mm Round Inner Cap (27)

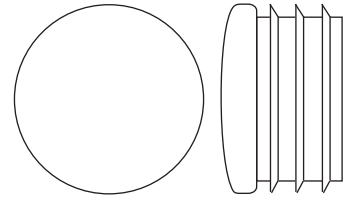

25mm Dome Inner Cap (25)



40mm x 50mm Inner Cap (23)

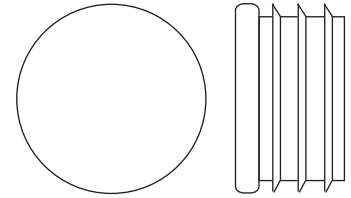

25mm Round Inner Cap (105)

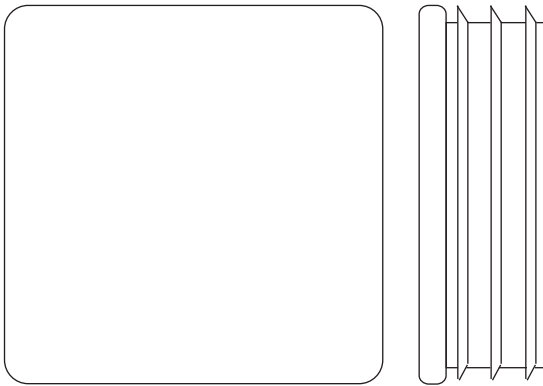

50mm Square Inner Cap (31)

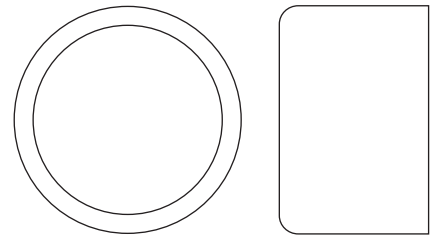

25mm Round Outer Cap (30)

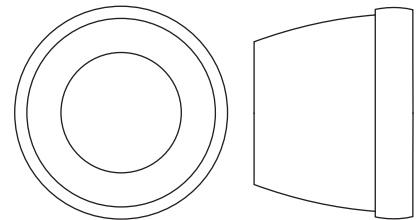

16mm Round Outer Cap (38)

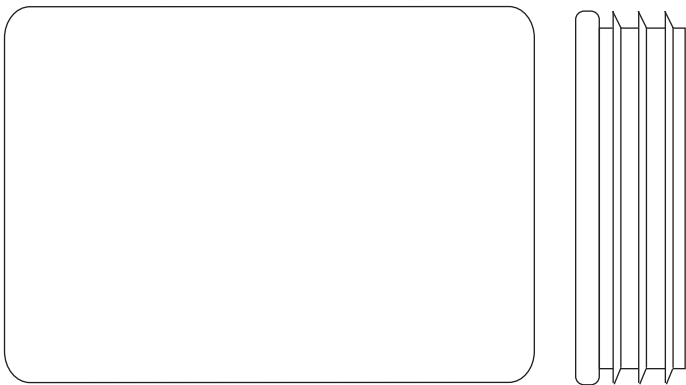

50mm x 70mm Inner Cap (103)

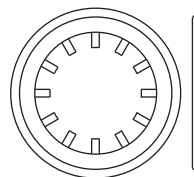

16mm Retainer (39)

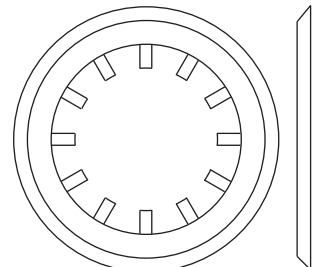

25mm Retainer (98)

PART IDENTIFICATION CHART



M6 Nylon Locknut (90)

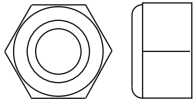

M8 Nylon Locknut (73)

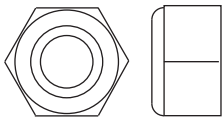

M10 Nylon Locknut (72)



M4 Washer (75)

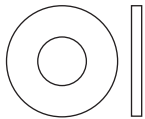

M6 Washer (69)

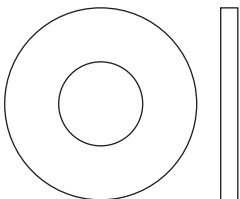

M10 Washer (71)

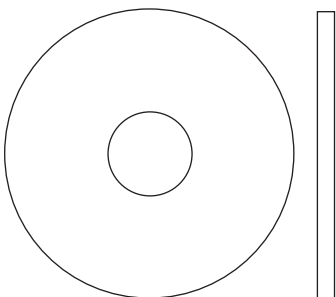

M10 Large Washer (108)

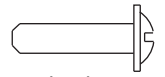

M4 x 16mm Self-tapping Screw (74)

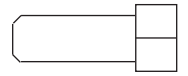

M6 x 16mm Screw (76)



M8 x 20mm Button Head Bolt (84)

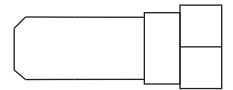

M8 x 20mm Shoulder Bolt (93)

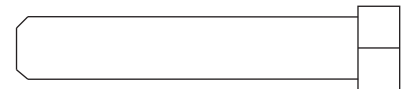

M8 x 45mm Bolt (96)

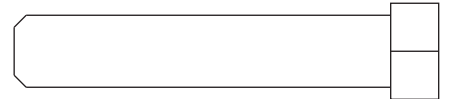

M10 x 50mm Bolt (85)

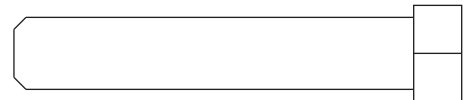

M10 x 53mm Bolt (88)



M10 x 55mm Bolt (80)

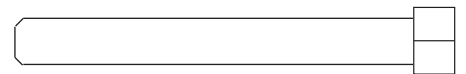

M6 x 53mm Screw (70)

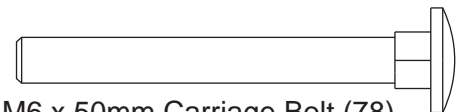

M6 x 50mm Carriage Bolt (78)

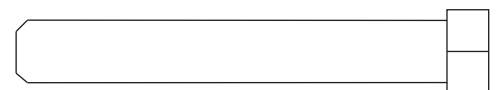

M8 x 57mm Bolt (79)

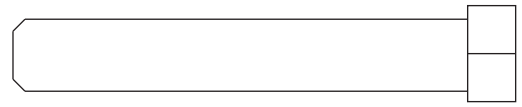

M10 x 60mm Bolt (95)



M6 x 65mm Screw (77)

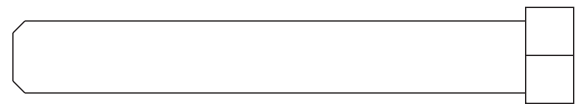

M10 x 68mm Bolt (87)

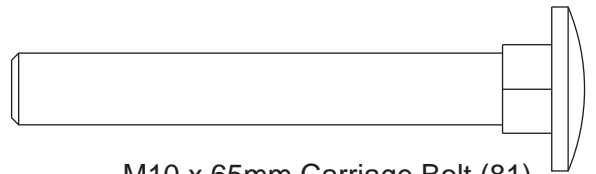

M10 x 65mm Carriage Bolt (81)

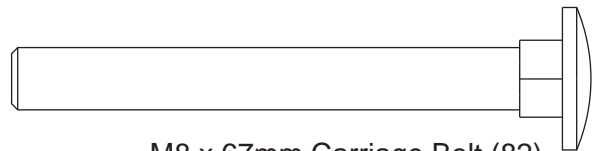

M8 x 67mm Carriage Bolt (82)



M10 x 67mm Carriage Bolt (107)

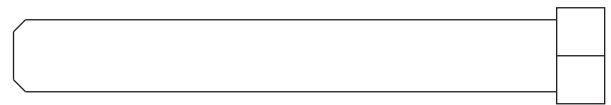

M10 x 72mm Bolt (89)

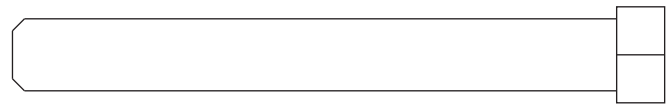

M10 x 80mm Bolt (83)

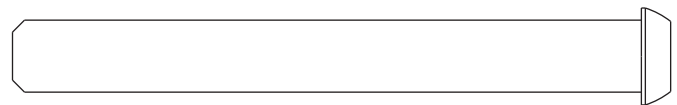

M10 x 83mm Button Head Bolt (86)

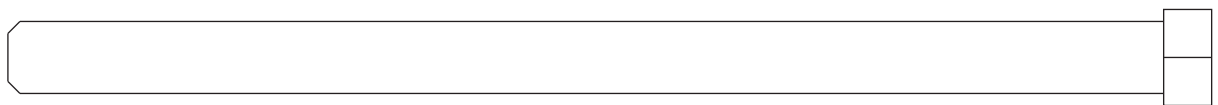

M10 x 153mm Bolt (91)