

Model No. DRMC20060

QUESTIONS?

As a manufacturer, we are committed to providing complete customer satisfaction. If you have questions, or if there are missing or damaged parts, we will guarantee you complete satisfaction through direct assistance from our factory.

TO AVOID UNNECESSARY DELAYS, PLEASE CALL DIRECT TO OUR TOLL-FREE CUSTOMER HOT LINE.

The trained technicians on our customer hot line will provide immediate assistance, free of charge to you.

CUSTOMER HOT LINE:

1-800-999-3756

Mon.-Fri., 6 a.m.-6 p.m. MST

WEIDER® ABShaper



CAUTION

Read all precautions and instructions in this manual before using this equipment. Save this manual for future reference.

PATENT PENDING

USER'S MANUAL

TO
6
RING

How to Use the AB SHAPER

The AB SHAPER offers a variety of exercises that shape your upper abdominals, oblique abdominals, and lower abdominals.

The photographs in this manual show the correct form for each exercise. If desired, attach this manual to the wall for reference.

The exercises in this manual are divided into four groups: Beginning, Intermediate, Advanced, and Expert. Start with the beginning exercises, and progress at your own pace. Be careful not to overdo it during the first few weeks of your exercise program. It is better to increase the number of repetitions you do than to advance to more difficult exercises too quickly. The intensity of each exercise can be varied by changing the position of your hands on the AB SHAPER handles. The lower your hands are positioned, the more difficult the exercise will be.

To get the most from your exercise, proper form is important. As you perform each repetition, use your abdominal muscles to pull yourself up, allowing the AB SHAPER to "roll" with you. **Do not press or pull the handles together.** Keep your head on the headrest and the small of your back on the exercise mat. If necessary, raise your hips slightly.

Always begin and end each workout with a few minutes of stretching. Remember to keep plenty of water nearby as you exercise, and drink periodically to avoid dehydration. **If you feel faint, dizzy, or short of breath at any time during exercise, stop immediately and begin cooling down.**

WARNING: Before you begin this or any exercise program, consult your physician. This is especially important for persons over the age of 35 or persons with pre-existing health problems. ICON assumes no responsibility for personal injury or property damage sustained by or through the use of this product.

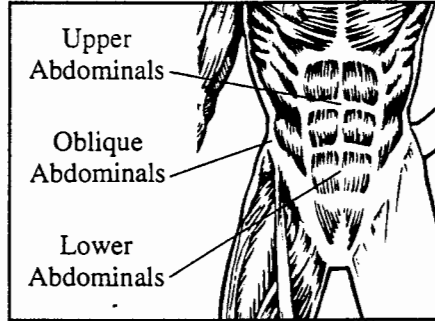

Suggested Stretches

Begin and end each workout with a few minutes of stretching. Stretching prepares the body for exercise by increasing the body temperature, heart rate, and circulation. After exercise, stretching allows the heart rate to return to normal and the muscles to cool down gradually. Stretching is also effective for increasing flexibility. The correct form for three basic stretches is shown below. Move slowly as you stretch—never bounce.

1. Hamstring Stretch

Extend one leg and rest the opposite foot against it as shown. Reach toward your toes and hold for 15 counts. Repeat 3 times for each leg.

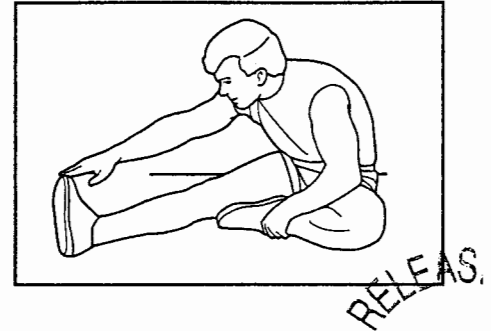

2. Toe Touch Stretch

Stand with your knees bent slightly as shown. Relax your back and shoulders as you reach down toward your toes. Hold for 15 counts. Repeat 3 times.

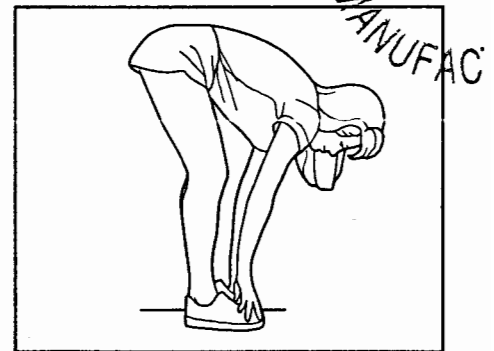

3. Quadriceps Stretch

Place one hand against a wall and grasp one foot with your other hand as shown. Hold your foot as close to your buttocks as possible, and hold for 15 counts. Repeat 3 times for each leg.



Expert Exercises

The expert exercises should be done only after you can comfortably perform the advanced exercises.

10. Bicycle Ab Crunch

This exercise focuses on the lower abdominals. Straighten your legs and hold them just off the floor as shown in photograph 10a. Curl up to about a 45° angle, bending one knee and raising it as shown in photograph 10b; then return to the starting position. Complete 10 to 15 repetitions, alternating legs with each repetition.

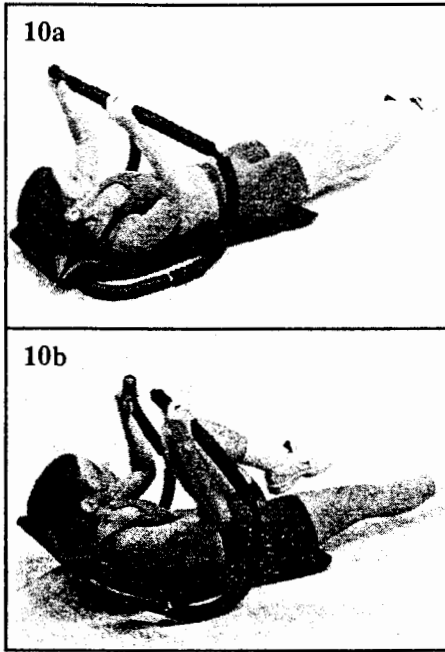

11. Jackknife

This exercise targets the lower abdominals. Straighten your legs and hold them just off the floor as shown in photograph 11a. Curl up to about a 45° angle, raising both legs as shown in photograph 11b; then return to the starting position. Complete 10 to 15 repetitions.

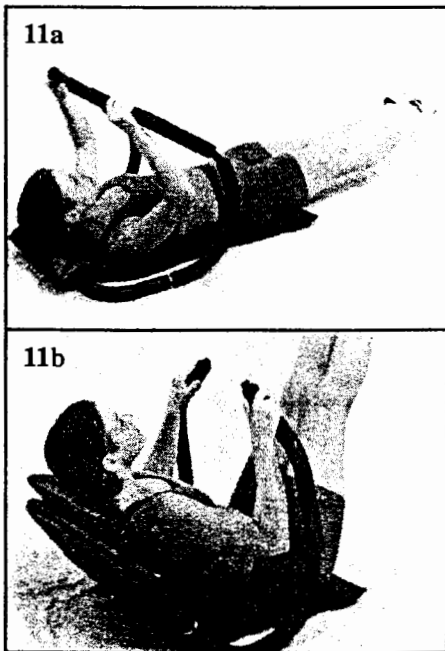

Expert Exercises—Cont.

12. Reverse Trunk

This exercise focuses on the oblique abdominals. Straighten your legs and raise them as shown in photograph 12a. Curl up to about a 45° angle. This is the starting position. Lower your legs to the side as shown in photograph 12b; then return to the starting position. Complete 10 to 15 repetitions, alternating sides with each repetition.

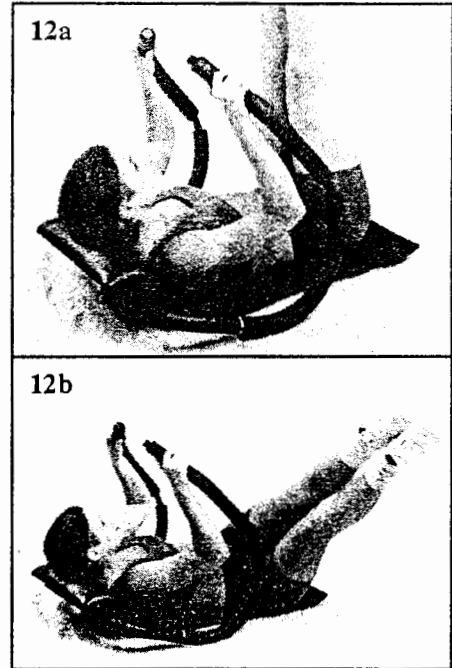

13. Scissors

This exercise focuses on the upper and lower abdominals. Hold your legs in the position shown in photograph 13a. Curl up to about a 45° angle. This is the starting position. Cross your ankles as shown in photograph 13b; then return to the starting position. Complete 10 to 15 repetitions, alternately crossing the right ankle above the left, and then the left ankle above the right.

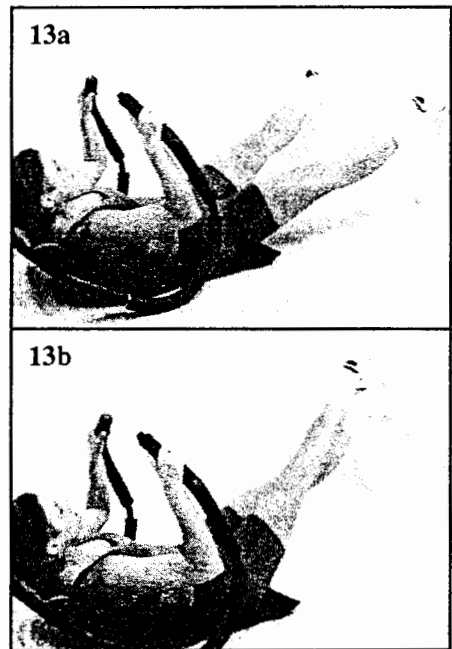

WEIDER® AB Shaper



Before You Begin

Congratulations for purchasing the innovative AB SHAPER from WEIDER. The AB SHAPER is designed to shape your upper abs, obliques, and lower abs to give you a firm, flat stomach, in only minutes a day. The unique AB SHAPER supports your head and neck as you exercise, and helps you maintain correct form for maximum results. Used as part of a fitness program that includes regular aerobic exercise and a proper diet, the AB SHAPER will help you to look better, feel better, and enjoy the benefits of better fitness.

Before you use the WEIDER® AB SHAPER, please read this manual carefully. In addition, be sure to view the included videocassette.

If you have additional questions, please call our Customer Service Department toll-free at 1-800-999-3756, Monday through Friday, 6 a.m. until 6 p.m. Mountain Time (excluding holidays). Please note the product model number before calling; the model number is DRMC20060.

Important Precautions

- Use the AB SHAPER only as described in this manual.
- As you exercise, keep the small of your back on the exercise mat; it may be necessary to raise your hips slightly.
- Keep your head on the headrest as you exercise.
- If you feel faint, dizzy, or short of breath at any time during exercise, stop immediately and begin cooling down.
- Read all instructions before you use the AB SHAPER. Before you begin this or any exercise program, consult your physician. This is especially important for persons over the age of 35 or persons with pre-existing health problems. ICON assumes no responsibility for personal injury or property damage sustained by or through the use of this product.

Setting Up the AB SHAPER

The AB SHAPER is shipped in the compact storage position. No assembly is necessary. Follow the simple steps below to set up the AB SHAPER.

1. Lay the exercise mat flat.

Raise one of the handles as shown.



2. Continue to raise the handle until the locking pin snaps into the pin groove.

Raise the other handle in the same way.

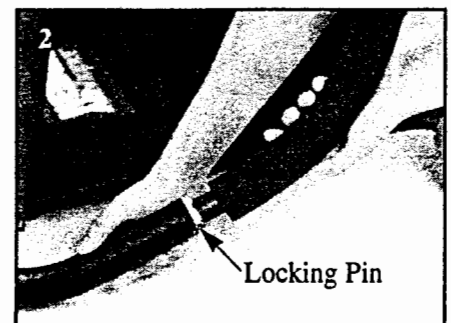

Storage and Maintenance

The instructions on the opposite side of this manual show how the AB SHAPER is used. When you are not using the AB SHAPER, it can be folded and stored under a bed. The AB SHAPER will even fit into the trunk of your car for easy transport. Follow the instructions below to fold the AB SHAPER to the storage position.

1. Hold one of the handles with one hand, and hold the frame with the other hand. **Firmly pull back the handle.**

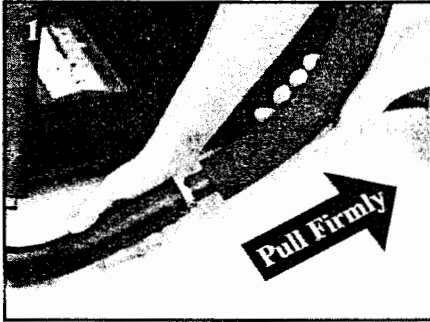

2. Rotate the handle down.

Rotate the other handle down in the same way.

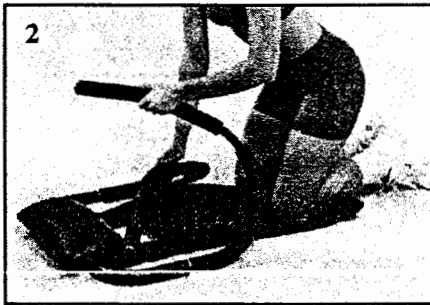

The AB SHAPER can be wiped clean with a damp cloth and mild, non-abrasive detergent. Do not use solvents.

Part List/Exploded Drawing

Key No.	Qty.	Description
1	1	Right Handle
2	2	1/4" x .6" Screw
3	4	#8 x 9/16" Screw
4	1	Left Handle
5	2	Spring
6	2	1" Round Cap
7	2	Sleeve
8	2	1/4" x 1 1/4" Pin
9	1	Frame
10	1	Exercise Mat w/Headrest
11	4	Foam Grip
#	1	User's Manual
#	1	Training Videocassette

Note: "#" indicates a non-illustrated part. Specifications are subject to change without notice. To order replacement parts, see the back cover of this manual.

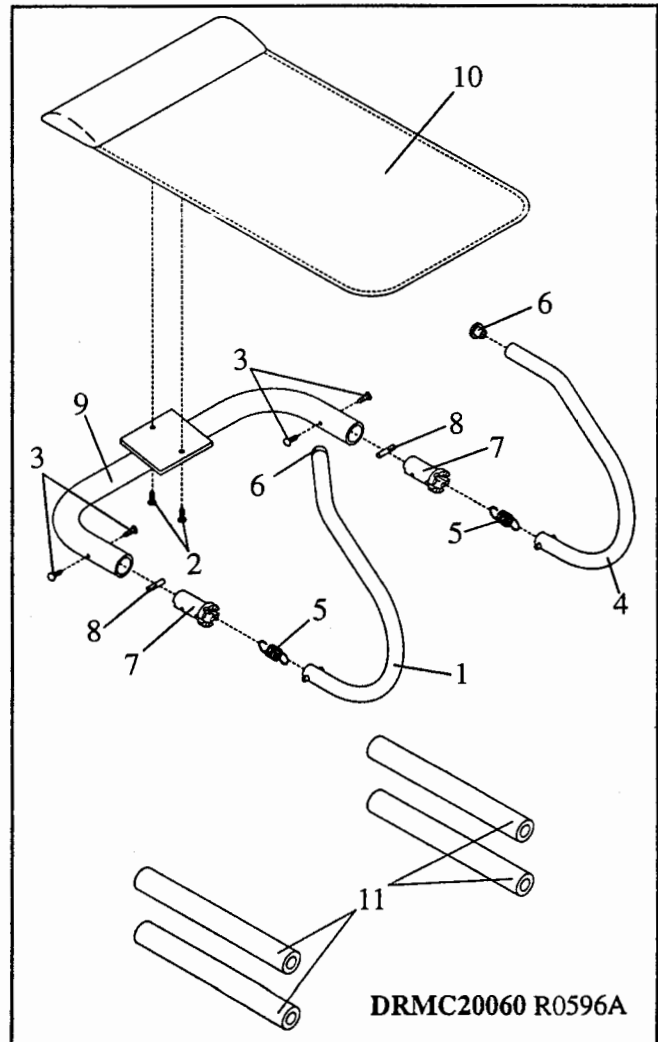

DRMC20060 R0596A

RELEASED TO
JUN 06 1996
MANUFACTURING

Intermediate Exercises—Cont.

6. Raised-knee Oblique Crunch

This exercise focuses on the oblique abdominals. Bend your knees, lay them to one side, and hold your legs just off the floor.

Curl up to about a 45° angle, then return to the starting position. Hold your legs stationary throughout the exercise. Complete 5 to 7 repetitions, change your knees to the opposite side, and then perform another 5 to 7 repetitions.

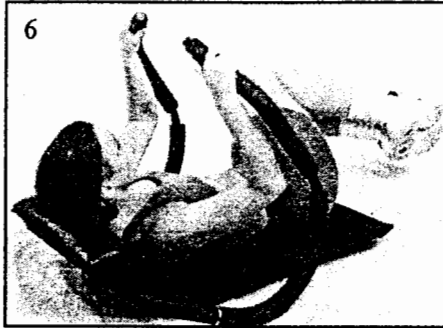

Advanced Exercises—Cont.

8. Advanced Raised-knee Crunch

This exercise focuses on the lower abdominals. Straighten your legs and hold them just off the floor as shown in photograph 8a. Curl up to about a 45° angle, bringing your knees toward your chest as shown in photograph 8b; then return to the starting position.

Complete 10 to 15 repetitions.

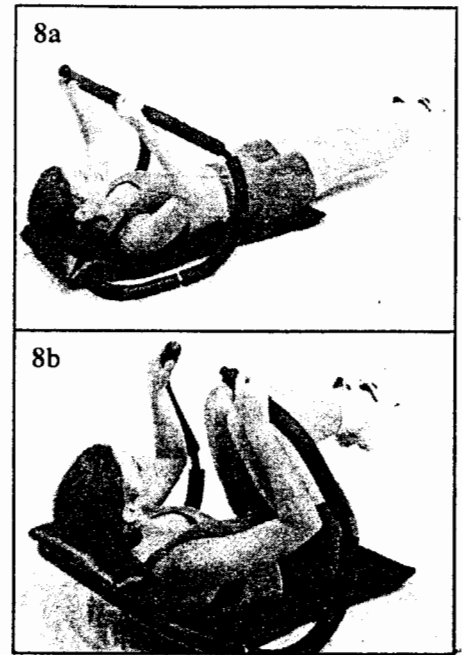

Advanced Exercises

The following exercises are designed to further improve your strength, tone, and flexibility. Remember to stretch for a few minutes before you begin.

7. "L"-Crunch

This exercise is for the upper abdominals. Straighten your legs and raise them as shown. Curl up to about a 45° angle, and then lower yourself to the starting position. Keep your legs raised throughout the exercise.

Complete 10 to 15 repetitions.



9. Advanced Oblique Leg Crunch

This exercise targets the oblique abdominals. Straighten your legs and hold them just off the floor as shown in photograph 9a. Curl up to about a 45° angle, bending your knees and bringing them to the side as shown in photograph 9b; then return to the starting position. Complete 10 to 15 repetitions, alternating sides with each repetition.

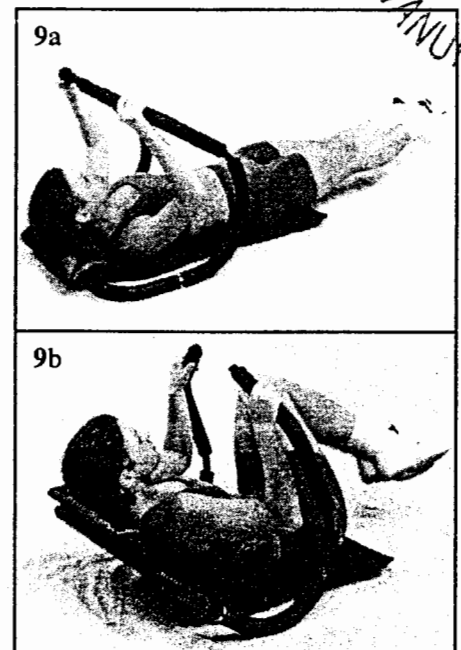

RELEASE

JUN 0

MANUFACTURE

Beginning Exercises

Be sure to stretch for a few minutes before you begin.

1. Basic Crunch

This exercise targets the upper abdominals. Lie on the exercise mat, and bend your knees as shown. Place your hands near the upper ends of the handles. Curl up to about a 45° angle, and then lower yourself to the starting position. This completes one repetition. Perform 10 to 15 repetitions.

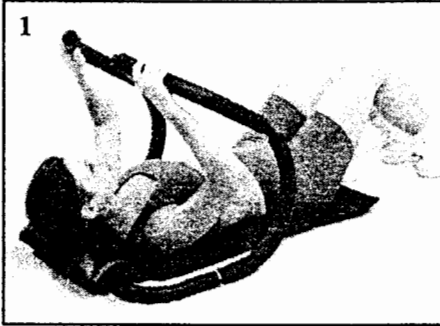

2. Basic Crunch with Raised Feet

This exercise focuses on the lower abdominals. This exercise should be performed in the same way as the Basic Crunch, except your feet should be held about one inch off the floor during the exercise. Complete 10 to 15 repetitions.

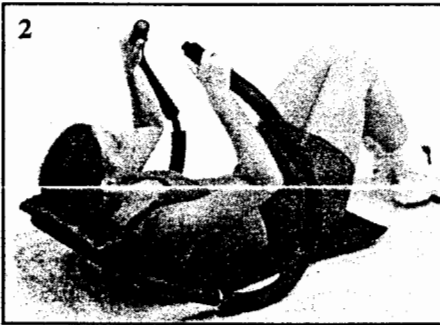

3. Basic Oblique Crunch

This exercise is for the oblique abdominals. Perform this exercise in the same way as the Basic Crunch, but turn your knees to the side as shown. Complete 5 to 7 repetitions, change your knees to the opposite side, and then perform another 5 to 7 repetitions.



Intermediate Exercises

As your abdominal muscles become stronger, and you can comfortably perform several repetitions of the beginning exercises, it is time to move on to the intermediate exercises. Remember to stretch for a few minutes before you begin.

4. Raised-knee Crunch with Knees Held to Chest

This exercise focuses on the upper abdominals. Lie on the exercise mat and bring your knees toward your chest as shown. Curl



up to about a 45° angle, and then lower yourself to the starting position. Keep your knees raised throughout the exercise. Complete 10 to 15 repetitions.

This exercise can also be performed by resting your feet on a chair.

5. Raised-knee Crunch with Knees Lifted to Chest

This exercise targets the lower abdominals. The starting position is shown in photograph 5a. Curl up to about a 45° angle, bringing your knees toward your chest at the same time; then return to the starting position. Perform 10 to 15 repetitions.



Ordering Replacement Parts

To order replacement parts, simply call our Customer Service Department toll-free at 1-800-999-3756, Monday through Friday, 6 a.m. until 6 p.m. Mountain Time (excluding holidays).

To help us assist you, please be prepared to give the following information:

- The MODEL NUMBER of the product (DRMC20060)
- The NAME of the product (WEIDER® AB SHAPER)
- The KEY NUMBER and DESCRIPTION of the part(s) (see the Part List and Exploded Drawing inside this manual).

Please have the AB SHAPER near your telephone for reference when calling.

WEIDER is a registered trademark of ICON Health & Fitness, Inc.

RELEASE
JUN 0
MANUFACT

Limited Warranty

ICON Health & Fitness, Inc. (ICON), warrants this product to be free from defects in workmanship and material, under normal use and service conditions, for a period of ninety (90) days from the date of purchase. This warranty extends only to the original purchaser. ICON's obligation under this warranty is limited to replacing or repairing, at ICON's option, the product at one of its authorized service centers. All products for which warranty claim is made must be received by ICON at one of its authorized service centers with all freight and other transportation charges prepaid, accompanied by sufficient proof of purchase. All returns must be pre-authorized by ICON. This warranty does not extend to any product or damage to a product caused by or attributable to freight damage, abuse, misuse, improper or abnormal usage or repairs not provided by an ICON authorized service center, to products used for commercial or rental purposes, or to products used as store display models. No other warranty beyond that specifically set forth above is authorized by ICON.

ICON is not responsible or liable for indirect, special or consequential damages arising out of or in connection with the use or performance of the product or damages with respect to any economic loss, loss of property, loss of revenues or profits, loss of enjoyment or use, costs of removal, installation or other consequential damages of whatsoever nature. Some states do not allow the exclusion or limitation of incidental or consequential damages. Accordingly, the above limitation may not apply to you.

The warranty extended hereunder is in lieu of any and all other warranties and any implied warranties of merchantability or fitness for a particular purpose is limited in its scope and duration to the terms set forth herein. Some states do not allow limitations on how long an implied warranty lasts. Accordingly, the above limitation may not apply to you.

This warranty gives you specific legal rights. You may also have other rights which vary from state to state.

ICON HEALTH & FITNESS, INC., 1500 S. 1000 W., LOGAN, UT 84321-9813