

aerostepper

by **WEIDER**®

Model No. WEST20021

QUESTIONS?

As a manufacturer, we are committed to providing complete customer satisfaction. If you have questions, or if there are missing parts, we will guarantee complete satisfaction through direct assistance from our factory.

TO AVOID DELAYS, PLEASE CALL DIRECT TO OUR TOLL-FREE CUSTOMER HOT LINE. The trained technicians on our customer hot line will provide immediate assistance, free of charge to you.

CUSTOMER HOT LINE:
1-800-288-4802
Mon.–Fri., 8 a.m.–5 p.m. CST

USER'S MANUAL

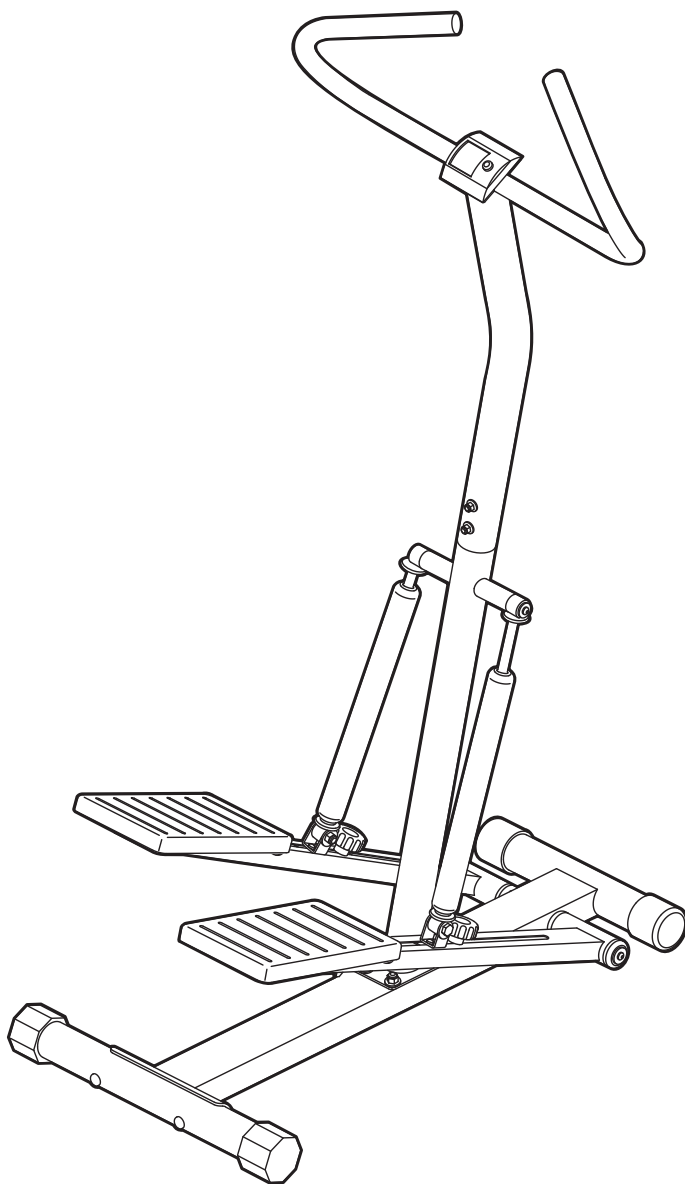

CAUTION

Read all precautions and instructions in this manual before using this equipment. Keep this manual for future reference.



Visit our website at

www.weiderfitness.com

*new products, prizes,
fitness tips, and much more!*

TABLE OF CONTENTS

IMPORTANT PRECAUTIONS	.2
BEFORE YOU BEGIN	.3
ASSEMBLY	.4
HOW TO USE THE STEPPER	.7
TROUBLESHOOTING AND MAINTENANCE	.8
CONDITIONING GUIDELINES	.9
PART LIST	.10
EXPLODED DRAWING	.11
HOW TO ORDER REPLACEMENT PARTS	.Back Cover
LIMITED WARRANTY	.Back Cover

IMPORTANT PRECAUTIONS

⚠ WARNING: To reduce the risk of serious injury, read the following important precautions before using the stepper.

1. Read all instructions in this manual before using the stepper. Use the stepper only as described.
2. It is the responsibility of the owner to ensure that all users of the stepper are adequately informed of all precautions.
3. The stepper is intended for in-home use only. Do not use the stepper in a commercial, rental, or institutional setting.
4. Keep the stepper indoors, away from moisture and dust. Place the stepper on a level surface, with a mat beneath it to protect the floor or carpet from damage.
5. Inspect and properly tighten all parts regularly. Replace any worn parts immediately.
6. Keep children under the age of 12 and pets away from the stepper at all times.
7. The stepper should not be used by persons weighing more than 250 pounds.
8. Wear appropriate clothes when exercising; do not wear loose clothes that could become caught on the stepper. Always wear athletic shoes for foot protection.
9. The resistance cylinders may become hot during use. Allow the cylinders to cool before touching them.
10. Always keep your back straight when using the stepper; do not arch your back.
11. If you feel pain or dizziness at any time while exercising, stop immediately and begin cooling down.
12. The decal shown below has been placed on the stepper. If the decal is missing, or if it is not legible, call our Customer Service Department toll-free to order a free replacement decal.

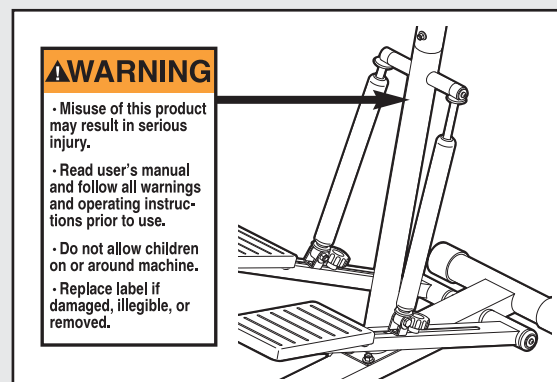

⚠ WARNING: Before beginning this or any exercise program, consult your physician. This is especially important for persons over the age of 35 or persons with pre-existing health problems. Read all instructions before using. ICON assumes no responsibility for personal injury or property damage sustained by or through the use of this product.

BEFORE YOU BEGIN

Thank you for selecting the new WEIDER® AERO STEPPER. The WEIDER® AERO STEPPER blends advanced engineering with contemporary styling to provide you with effective, low-impact workouts in the convenience and privacy of your own home.



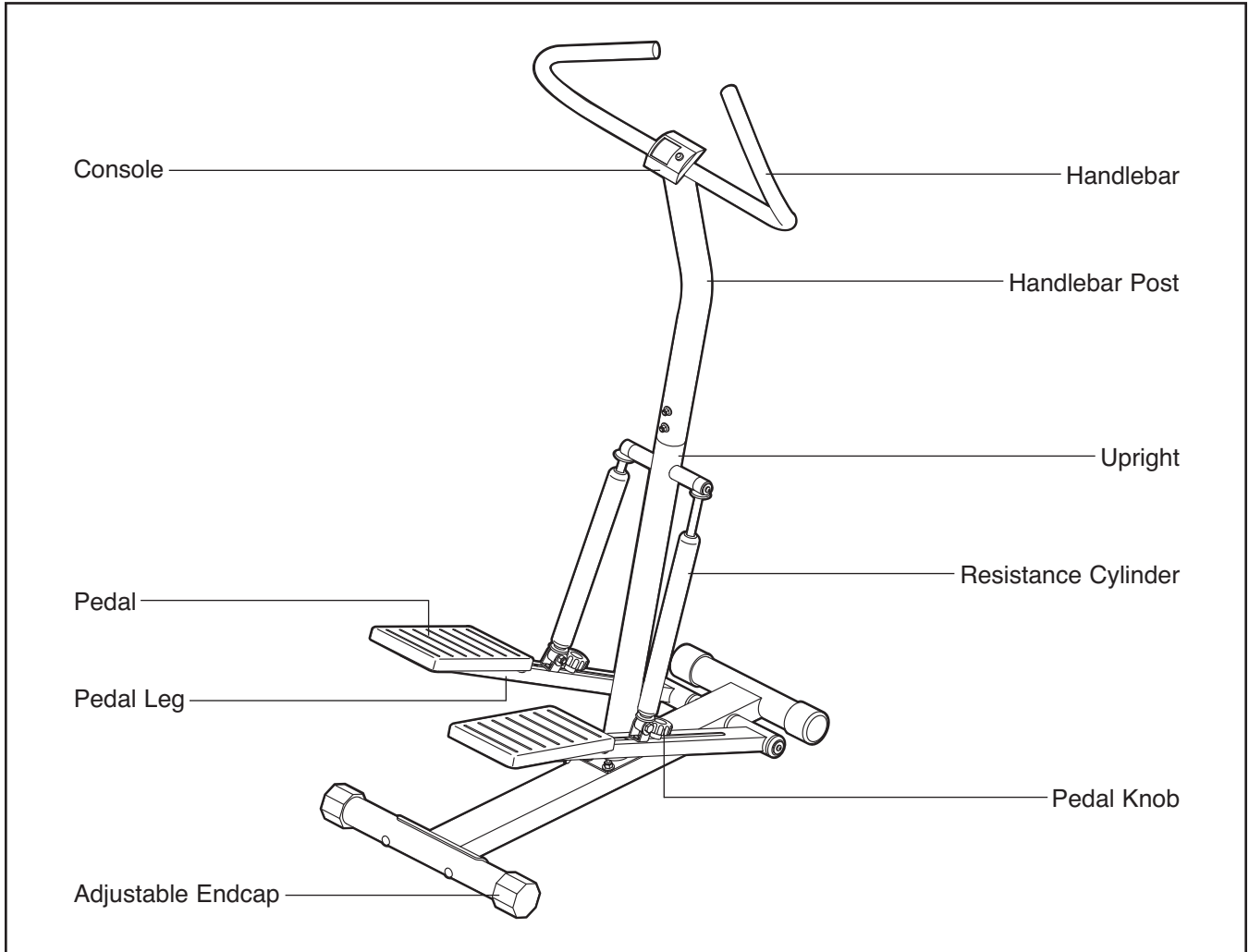

For your benefit, read this manual carefully before using the stepper. If you have questions after reading this manual, please call our Customer Service

Department toll-free at 1-800-288-4802, Monday through Friday, 8 a.m. until 5 p.m. Central Time (excluding holidays). To help us assist you, please mention the product model number when calling. The model number is WEST20021.

Before reading further, please familiarize yourself with the parts that are labeled in the drawing below.



ASSEMBLY

Place all parts of the stepper in a cleared area and remove the packing materials. Do not dispose of the packing materials until assembly is completed. **Assembly requires the included allen wrench**  **and your own phillips screwdriver** , **adjustable wrenches**  **and rubber mallet** .

Refer to the drawings below for help identifying the small parts used during assembly. The number in parenthesis below each drawing is the key number of the part, from the PART LIST on page 10. The number following the key number is the quantity required for assembly. **Note: If a part is not found in the parts bag, check to see if it has been preassembled.**

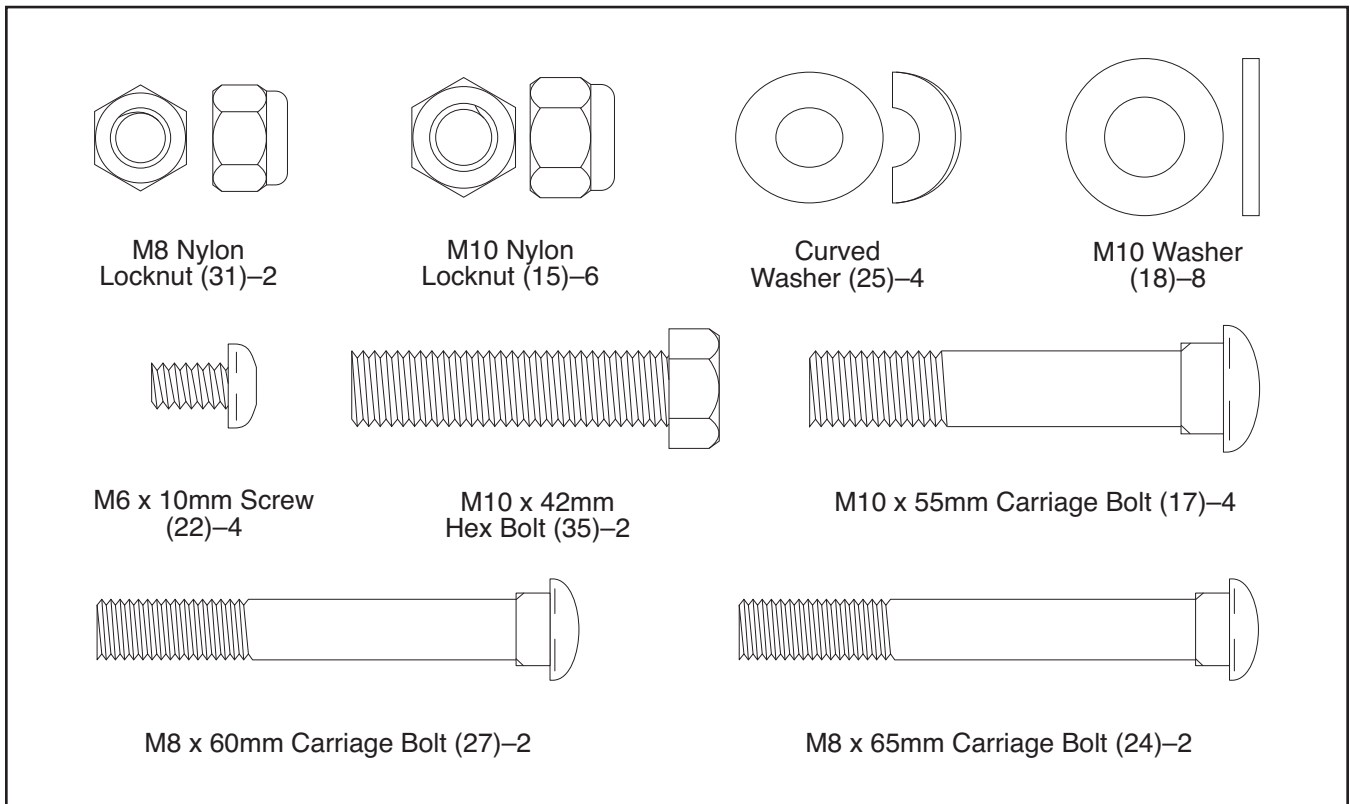

1. Press an Adjustable Endcap (5) onto each end of the Rear Stabilizer (8).

Attach the Rear Stabilizer (8) to the Base (2) with two M8 x 65mm Carriage Bolts (24), two Curved Washers (25), and two M8 Nylon Locknuts (31).

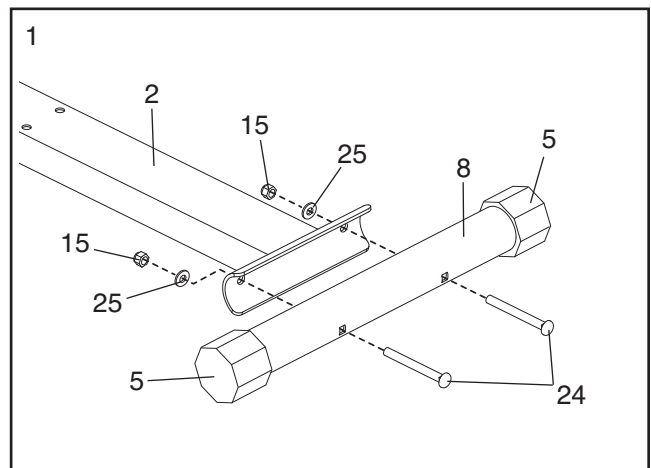

2. Peel the backing off the adhesive on the bottom of a Pedal (11). Press the Pedal onto the metal plate on the Left Pedal Leg (6) as shown.

Attach a Pedal (11) to the Right Pedal Leg (7) in the same way.

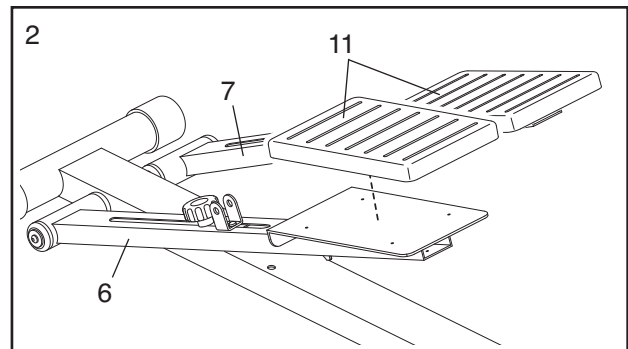

3. Insert four M10 x 55mm Carriage Bolts (17) up into the indicated holes in the Base (2). Slide the Upright (1) onto the Carriage Bolts. **Make sure that the Upright is angled in the direction shown.** Tighten four M10 Nylon Locknuts (15) with four M10 Washers (18) onto the Carriage Bolts.

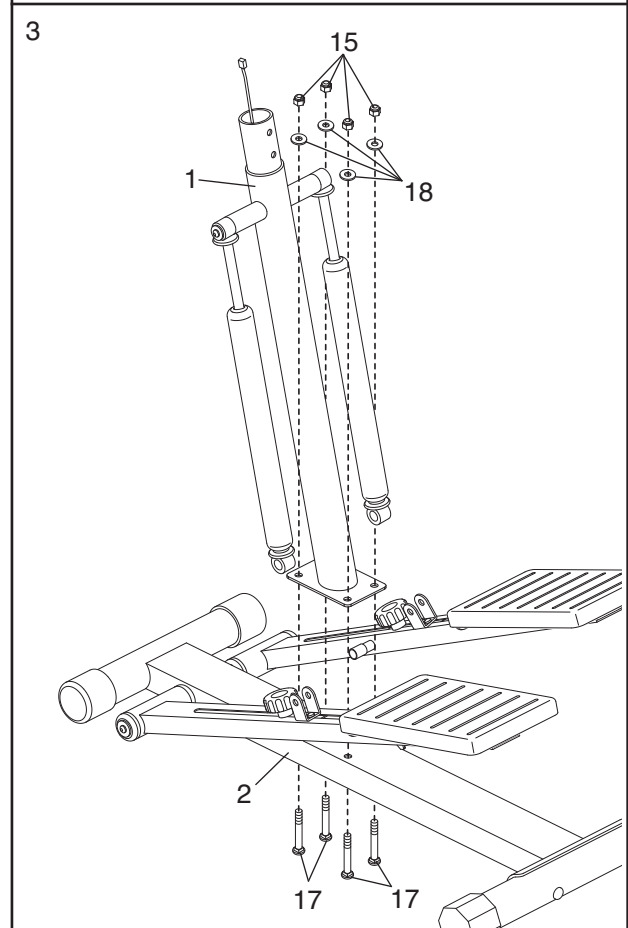

4. Hold the lower end of the left Resistance Cylinder (9) inside the U-Bracket (32) on the Left Pedal Leg (6). Attach the Resistance Cylinder with an M10 x 42mm Hex Bolt (35), two M10 Washers (18), and an M10 Nylon Locknut (15).

Attach the right Resistance Cylinder (9) to the U-Bracket (32) on the Right Pedal Leg (7) in the same way.

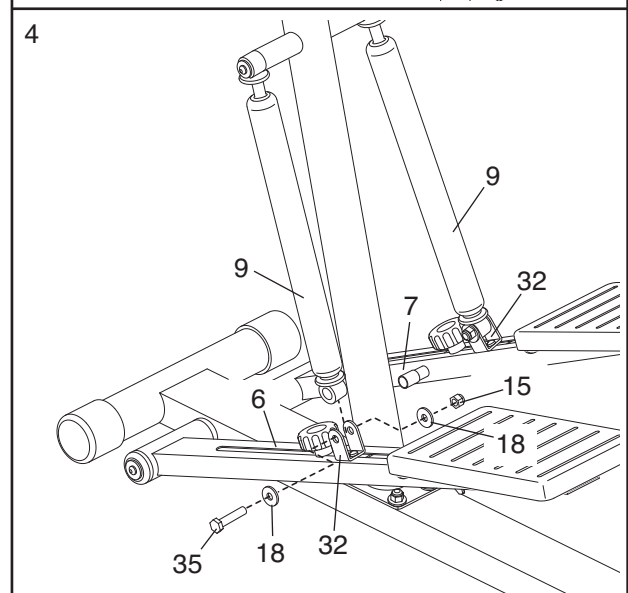

5. Route the Reed Switch Wire (12) up through the Handlebar Post (3). Next, slide the Handlebar Post onto the Upright (1). Attach the Handlebar Post with two M8 x 60mm Carriage Bolts (27), two Curved Washers (25), and two M8 Nylon Locknuts (31). **Be careful to avoid pinching the Reed Switch Wire.**

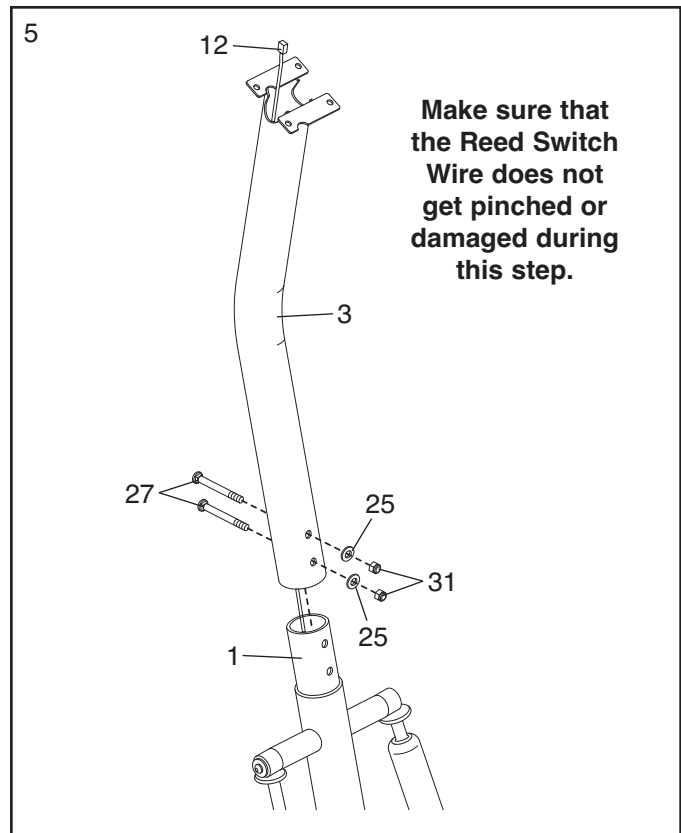

6. Insert the Reed Switch Wire (12) up through the indicated hole in the Handlebar (4). Attach the Handlebar to the Upright (1) with four M6 x 10mm Screws (22). **Be careful to avoid pinching the Reed Switch Wire.**

Connect the Reed Switch Wire (12) to the Console (10). Snap the Console onto the Handlebar (4). **Be careful to avoid pinching the Reed Switch Wire.**

7. **Make sure that all parts are properly tightened before you use the stepper.**

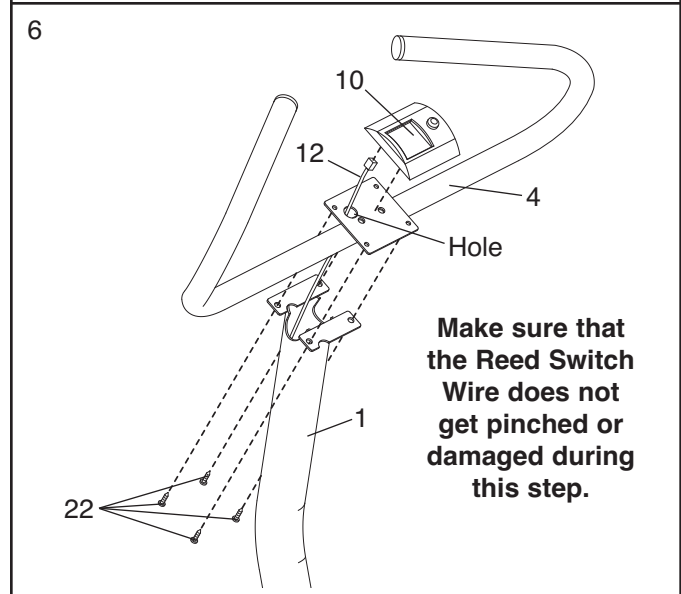

HOW TO USE THE STEPPER

HOW TO EXERCISE ON THE STEPPER

Place the stepper on a level surface, with a mat beneath it. Note: The stepper features precision hydraulic cylinders. There is a possibility of slight oil leakage due to the nature of hydraulic cylinders.

Hold the handlebars and step onto the pedals. Begin stepping, alternately pushing down the right and left pedals with a smooth, continuous motion. Because the pedals move independently, you must maintain a continuous motion or both pedals will sink to the floor. Adjust your pace or the height of your step until you can comfortably maintain a continuous motion.

To exercise your upper leg muscles, keep your feet flat on the pedals as you step. To focus on your calf muscles, rise on your toes as you step. Stand erect or lean forward slightly as you exercise; always keep your back straight to avoid injury.

HOW TO CHANGE THE RESISTANCE

To change the resistance of the pedals, first turn the pedal knobs counterclockwise to loosen them. Slide the resistance cylinders forward along the pedal legs to decrease the resistance or backward to increase the resistance. **Make sure that both resistance cylinders are in the same position.** When the resistance cylinders are in the desired position, retighten the pedal knobs. **Make sure that the metal pin on each knob is inserted into one of the eight holes in the underside of each pedal leg.**

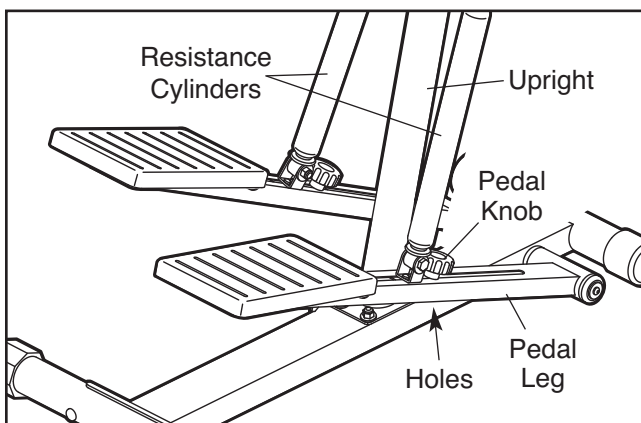

⚠ WARNING: The resistance cylinders become very hot during use. Allow the resistance cylinders to cool before touching them.

HOW TO USE THE CONSOLE

If there is a thin sheet of clear plastic on the console, remove the plastic. To turn on the console, press the MODE/RESET button or begin stepping.

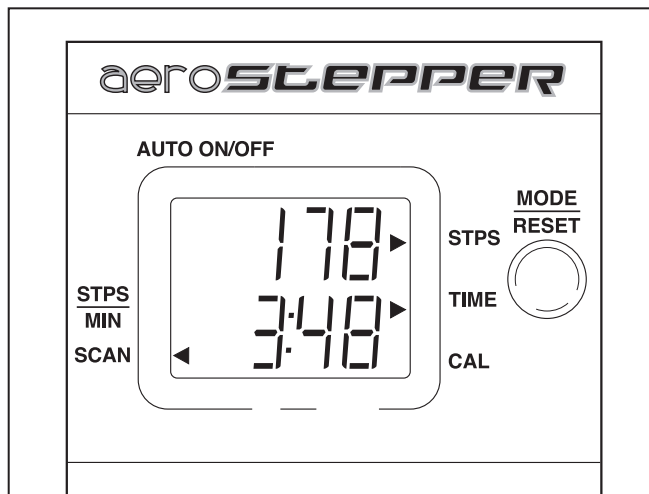

As you step, the upper half of the display will show the total number of steps you have completed. A mode arrow will point to the letters "STPS."

The lower half of the display will show the elapsed time, the approximate number of calories you have burned, and your stepping speed, changing from one mode to the next every few seconds. One mode arrow will point to the word "SCAN," and a second mode arrow will point to the letters "TIME," "CAL," or "STPS/MIN."

To view one mode continuously in the lower half of the display, press the MODE/RESET button until there is a mode arrow pointing to the letters "TIME," "CAL," or "STPS/MIN" but no mode arrow pointing to the word "SCAN." To view all three modes again, press the button until there is a mode arrow pointing to the word "SCAN."

To reset the display, press the MODE/RESET button for about two seconds.

If the pedals are not moved and the MODE/RESET button is not pressed for a few seconds, the word "STOP" will appear in the left side of the display. If the pedals are not moved and the button is not pressed for a few minutes, the console will turn off.

MAINTENANCE AND TROUBLESHOOTING

Inspect and properly tighten all parts each time you use the stepper. Clean the stepper using a soft cloth and mild, non-abrasive detergent.

To prevent damage to the console, keep liquids away from the console and keep the console out of direct sunlight.

BATTERY REPLACEMENT

The console requires one type-LR44 watch battery. To replace the battery, gently pry off the top of the console. Remove the old battery from the holder and insert a new battery in the same position. Press the top of the console back into place.

LEVELING THE STEPPER

If the ends of both stabilizers do not sit flat on your floor, turn one or both of the adjustable endcaps until the rocking motion is eliminated.

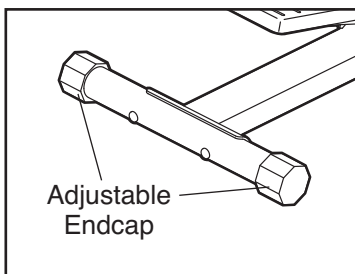

ADJUSTING THE REED SWITCH

If the console does not function properly, or if the display becomes faint, the battery should be replaced. See BATTERY REPLACEMENT at the left.

If the console still does not function properly, the Reed Switch (not shown) should be adjusted. See the inset drawing. Raise or lower the Right Pedal Leg (7) until the Magnet (26) is aligned with the Reed Switch (12). Slide the Reed Switch in or out of its holder until there is a gap of about 1/8"

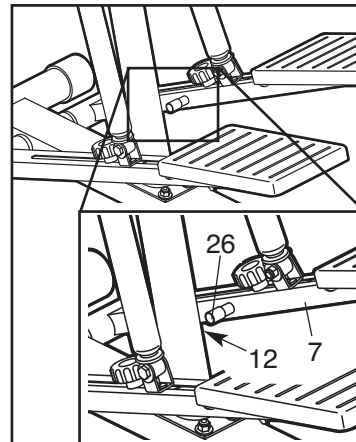

between the Reed Switch and the Magnet. Make sure that the Magnet will not hit the Reed Switch when the Right Pedal Leg is moved. Repeat until the console displays correct feedback.

CONDITIONING GUIDELINES

The following guidelines will help you to plan your exercise program. Remember that proper nutrition and adequate rest are essential for successful results.

⚠ WARNING: Before beginning this or any exercise program, consult your physician. This is especially important for persons over the age of 35 or persons with pre-existing health problems.

EXERCISE INTENSITY

Whether your goal is to burn fat or to strengthen your cardiovascular system, the key to achieving the desired results is to exercise with the proper intensity. The proper intensity level can be found by using your heart rate as a guide. The chart below shows recommended heart rates for fat burning, maximum fat burning, and cardiovascular (aerobic) exercise.

165	155	145	140	130	125	115	♥
145	138	130	125	118	110	103	♥
125	120	115	110	105	95	90	♥
20	30	40	50	60	70	80	

To find the proper heart rate for you, first find your age near the bottom of the chart (ages are rounded off to the nearest ten years). Next, find the three numbers above your age. The three numbers are your “training zone.” The lowest number is the recommended heart rate for fat burning, the middle number is the recommended heart rate for maximum fat burning, and the highest number is the recommended heart rate for aerobic exercise.

Fat Burning

To burn fat effectively, you must exercise at a relatively low intensity level for a sustained period of time. During the first few minutes of exercise, your body uses easily accessible *carbohydrate* calories for energy. Only after the first few minutes of exercise does your body begin to use stored *fat* calories for energy. If your goal is to burn fat, adjust the intensity of your exercise until your heart rate is between the lowest number and the middle number in your training zone as you exercise.

Aerobic Exercise

If your goal is to strengthen your cardiovascular system, your exercise must be “aerobic.” Aerobic exercise is activity that requires large amounts of oxygen for prolonged periods of time. This increases the demand on the heart to pump blood to the muscles, and on the lungs to oxygenate the blood. For aerobic exercise, adjust the intensity of your exercise until your heart rate is near the highest number in your training zone.

HOW TO MEASURE YOUR HEART RATE

To measure your heart rate, first exercise for at least four minutes. Then, stop exercising and place two fingers on your wrist as shown. Take a six-second heartbeat count, and multiply the result by 10



to find your heart rate. For example, if your six-second heartbeat count is 14, your heart rate is 140 beats per minute. (A six-second count is used because your heart rate will drop rapidly when you stop exercising.)

WORKOUT GUIDELINES

Each workout should include the following three parts:

A warm-up, consisting of 5 to 10 minutes of stretching and light exercise. A proper warm-up increases your body temperature, heart rate, and circulation in preparation for exercise.

Training zone exercise, consisting of 20 to 30 minutes of exercising with your heart rate in your training zone. Note: During the first few weeks of your exercise program, do not keep your heart rate in your training zone for longer than 20 minutes.

A cool-down, with 5 to 10 minutes of stretching. This will increase the flexibility of your muscles and will help to prevent post-exercise problems.

EXERCISE FREQUENCY

To maintain or improve your condition, plan three workouts each week, with at least one day of rest between workouts. After a few months of regular exercise, you may complete up to five workouts each week, if desired. Remember, the key to success is make exercise a regular and enjoyable part of your everyday life.

PART LIST—Model No. WEST20021

R0703A

Key No.	Qty.	Description	Key No.	Qty.	Description
1	1	Upright	22	10	M6 x 10mm Screw
2	1	Base	23	2	Foam Grip
3	1	Handlebar Post	24	2	M8 x 65mm Carriage Bolt
4	1	Handlebar	25	4	Curved Washer
5	2	Adjustable Endcap	26	1	Magnet
6	1	Left Pedal Leg	27	2	M8 x 60mm Carriage Bolt
7	1	Right Pedal Leg	28	4	M10 x 20mm Hex Screw
8	1	Rear Stabilizer	29	2	Pedal Bumper
9	2	Resistance Cylinder w/Bushing	30	2	Pedal Leg Endcap
10	1	Console	31	4	M8 Nylon Locknut
11	2	Pedal	32	2	U-Bracket
12	1	Reed Switch/Wire	33	2	Slide Plate
13	2	Round Endcap	34	2	Pedal Knob
14	1	Grommet	35	2	M10 x 42mm Hex Bolt
15	6	M10 Nylon Locknut	36	1	Magnet Base
16	2	Pedal Leg Outer Bushing	37	2	Knob Washer
17	4	M10 x 55mm Carriage Bolt	38	2	Pedal Leg Inner Bushing
18	10	M10 Washer	#	1	User's Manual
19	2	Cylinder Spacer	#	1	Grease Packet
20	2	Handlebar Endcap	#	1	Allen Wrench
21	2	Large M10 Washer			

Note: “#” refers to a non-illustrated part. Specifications are subject to change without notice. See the back cover of this manual for information about ordering replacement parts.

EXPLODED DRAWING—Model No. WEST20021

R0703A

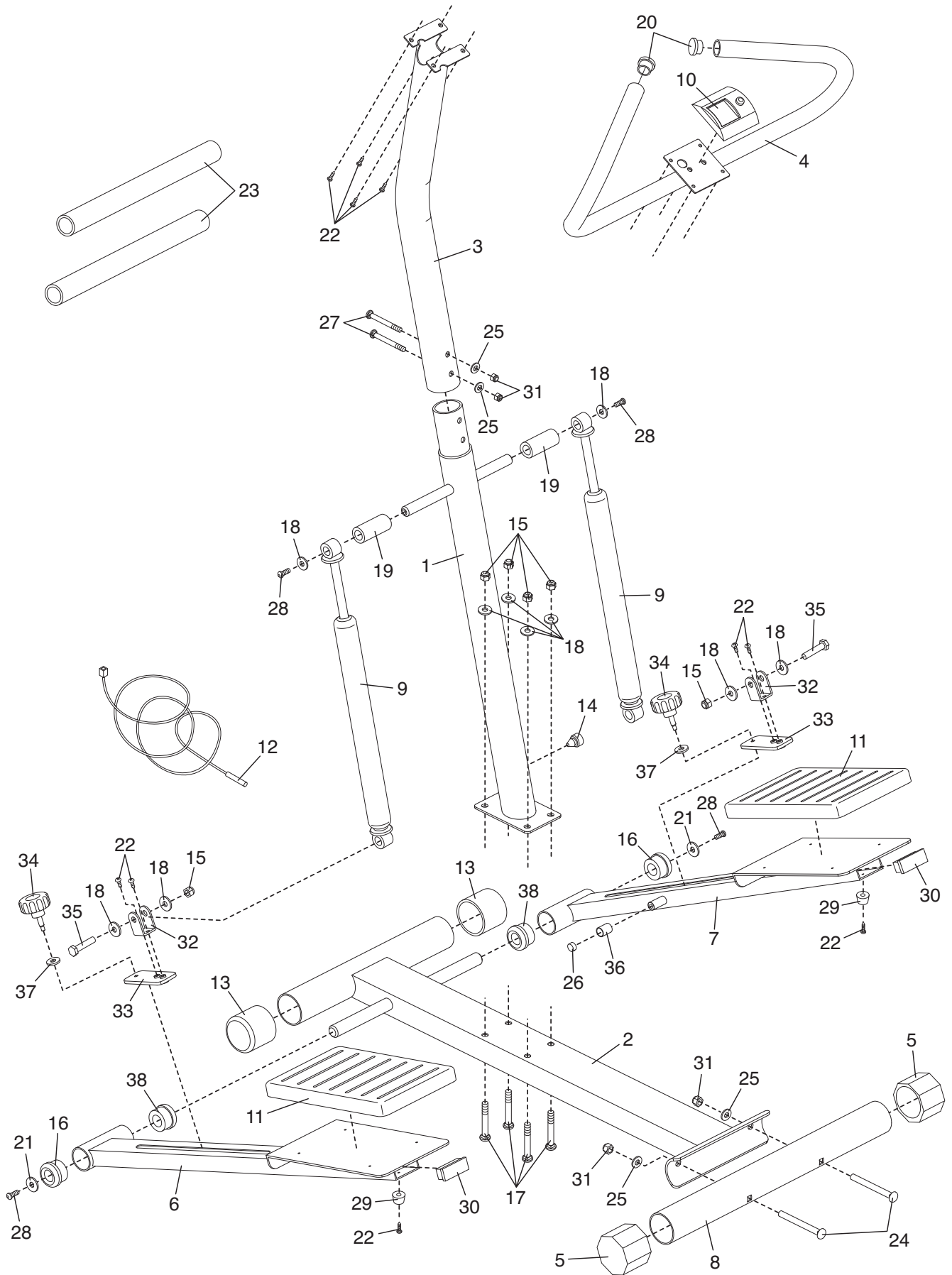

HOW TO ORDER REPLACEMENT PARTS

To order replacement parts, call our Customer Service Department toll-free at 1-800-288-4802, Monday through Friday, 8 a.m. until 5 p.m. Central Time (excluding holidays). To help us assist you, please be prepared to give the following information:

- The MODEL NUMBER of the product (WEST20021)
- The NAME of the product (WEIDER® AERO STEPPER)
- The KEY NUMBER and DESCRIPTION of the part(s) (see the PART LIST on page 10)

WEIDER is a registered trademark of ICON Health & Fitness, Inc.

LIMITED WARRANTY

ICON Health & Fitness, Inc. (ICON), warrants this product to be free from defects in workmanship and material, under normal use and service conditions, for a period of ninety (90) days from the date of purchase. This warranty extends only to the original purchaser. ICON's obligation under this warranty is limited to replacing or repairing, at ICON's option, the product through one of its authorized service centers. All repairs for which warranty claims are made must be pre-authorized by ICON. This warranty does not extend to any product or damage to a product caused by or attributable to freight damage, abuse, misuse, improper or abnormal usage or repairs not provided by an ICON authorized service center; products used for commercial or rental purposes; or products used as store display models. No other warranty beyond that specifically set forth above is authorized by ICON.

ICON is not responsible or liable for indirect, special or consequential damages arising out of or in connection with the use or performance of the product or damages with respect to any economic loss, loss of property, loss of revenues or profits, loss of enjoyment or use, costs of removal or installation or other consequential damages of whatsoever nature. Some states do not allow the exclusion or limitation of incidental or consequential damages. Accordingly, the above limitation may not apply to you.

The warranty extended hereunder is in lieu of any and all other warranties and any implied warranties of merchantability or fitness for a particular purpose is limited in its scope and duration to the terms set forth herein. Some states do not allow limitations on how long an implied warranty lasts. Accordingly, the above limitation may not apply to you.

This warranty gives you specific legal rights. You may also have other rights which vary from state to state.

ICON HEALTH & FITNESS, INC., 1500 S. 1000 W., LOGAN, UT 84321-9813