

WEIDER® Club 4870

Model No. WESY3906.0

Serial No. _____

Write the serial number in the space above for future reference.

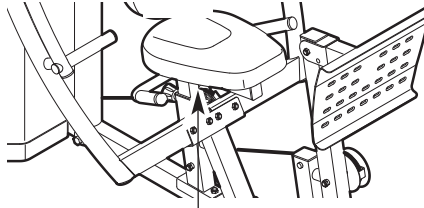

Serial Number Decal (Under Seat)

USER'S MANUAL

QUESTIONS?

As a manufacturer, we are committed to providing complete customer satisfaction. If you have questions, or if a part is damaged or missing, PLEASE CONTACT OUR CUSTOMER SERVICE DEPARTMENT DIRECTLY.

CALL TOLL-FREE:

1-877-992-5999

Mon.–Fri., 6 a.m.–6 p.m. MST

ON THE WEB:

www.weiderservice.com

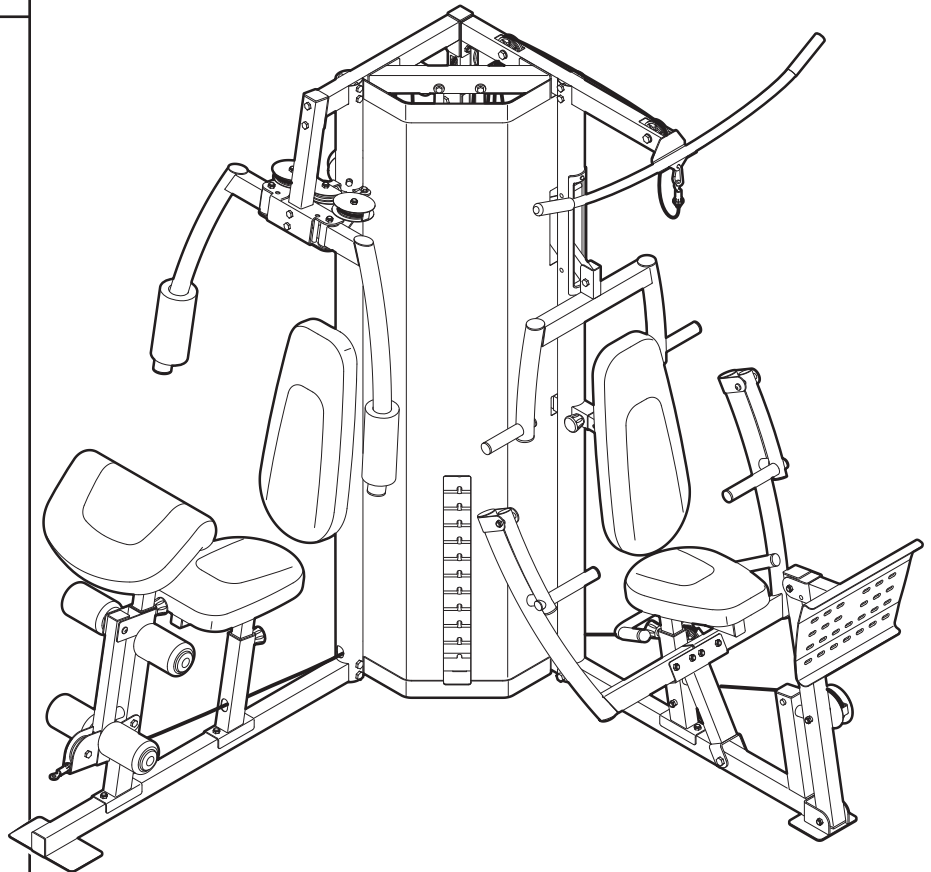

⚠ CAUTION

Read all precautions and instructions in this manual before using this equipment. Save this manual for future reference.



Visit our website at

www.weiderfitness.com

new products, prizes,
fitness tips, and much more!

TABLE OF CONTENTS

WARNING DECAL PLACEMENT	2
IMPORTANT PRECAUTIONS	3
BEFORE YOU BEGIN	4
PART IDENTIFICATION CHART	5
ASSEMBLY	7
ADJUSTMENTS	25
CABLE DIAGRAM	28
EXERCISE GUIDELINES	29
PART LIST	32
EXPLODED DRAWING	33
ORDERING REPLACEMENT PARTS	Back Cover
LIMITED WARRANTY	Back Cover

WARNING DECAL PLACEMENT

The decals shown here have been placed on the weight system. If a decal is missing or illegible, please call the toll-free telephone number on the front cover of this manual and order a free replacement decal. Apply the decal in the location shown.

▲ WARNING

- Misuse of this machine may result in serious injury.
- Read user's manual prior to use and follow all warnings and instructions.
- Do not allow children on or around machine.
- Keep body, clothing, and hair free and clear of all moving parts.
- Replace label if damaged, illegible, or removed.

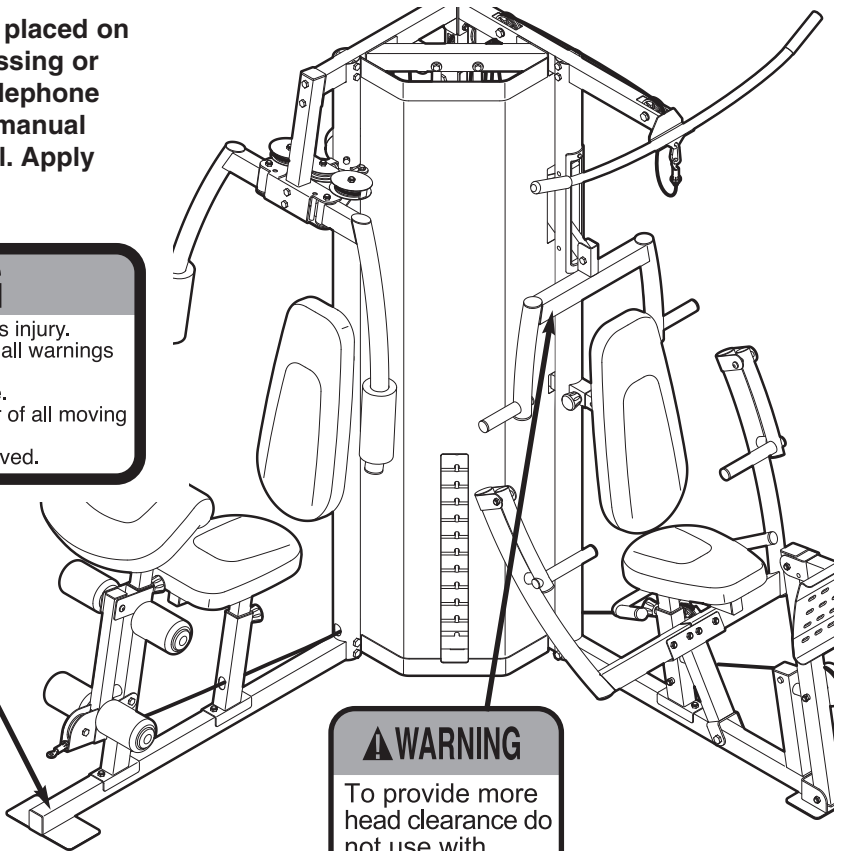

▲ WARNING

To provide more head clearance do not use with backrest in rear position.

IMPORTANT PRECAUTIONS

⚠ WARNING: To reduce the risk of serious injury, read the following important precautions before using the weight system.

1. Read all instructions in this manual and all warnings on the weight system before using the weight system. Use the weight system only as described in this manual.
2. It is the responsibility of the owner to ensure that all users of the weight system are adequately informed of all precautions.
3. The weight system is intended for home use only. Do not use the weight system in any commercial, rental, or institutional setting.
4. Keep the weight system indoors, away from moisture and dust. Place the weight system on a level surface, with a mat beneath it to protect the floor or carpet. Make sure that there is enough clearance around the weight system to mount, dismount, and use the weight system.
5. Inspect and properly tighten all parts regularly. Replace any worn parts immediately.
6. Keep children under 12 and pets away from the weight system at all times.
7. Keep hands and feet away from moving parts.
8. Always wear athletic shoes for foot protection while exercising.
9. Make sure that the cables remain on the pulleys at all times. If the cables bind as you are exercising, stop immediately and make sure that the cables are on the pulleys. Replace all cables at least every two years.
10. The weight system is designed to support a maximum user weight of 300 pounds.
11. The weight system is designed to be used only with the included weight. Do not use the weight system with dumbbells or any other type of weight to increase the resistance.
12. Never release the arms, leg lever, lat bar, leg press, ankle strap, or handle while weights are raised. The weights will fall with great force.
13. Always disconnect the lat bar from the weight system when performing an exercise that does not use the lat bar.
14. Do not use the weight system with the top weight pinned in an elevated position.
15. Always secure the weight stack with the lock pin and lock after exercising to prevent unauthorized use of the weight system (see LOCKING THE WEIGHT STACK on page 26).
16. If you feel pain or dizziness at any time while exercising, stop immediately and begin cooling down.

⚠ WARNING: Before beginning this or any exercise program, consult your physician. This is especially important for persons over the age of 35 or persons with pre-existing health problems. Read all instructions before using. ICON assumes no responsibility for personal injury or property damage sustained by or through the use of this product.

BEFORE YOU BEGIN

Thank you for selecting the versatile WEIDER® Club 4870 weight system. The weight system offers a selection of weight stations designed to develop every major muscle group of the body. Whether your goal is to tone your body, build dramatic muscle size and strength, or improve your cardiovascular system, the weight system will help you to achieve the specific results you want.

For your benefit, read this manual carefully before using the weight system. If you have questions after reading this manual, see the front cover of this manual. To help us assist you, please note the product

model number and serial number before calling. The model number is WESY3906.0. The serial number can be found on a decal attached to the weight system (see the front cover of this manual).

To avoid a registration fee for any service needed under warranty, you must register the weight system at www.weiderservice.com/registration.

Before reading further, please review the drawing below and familiarize yourself with the parts that are labeled.

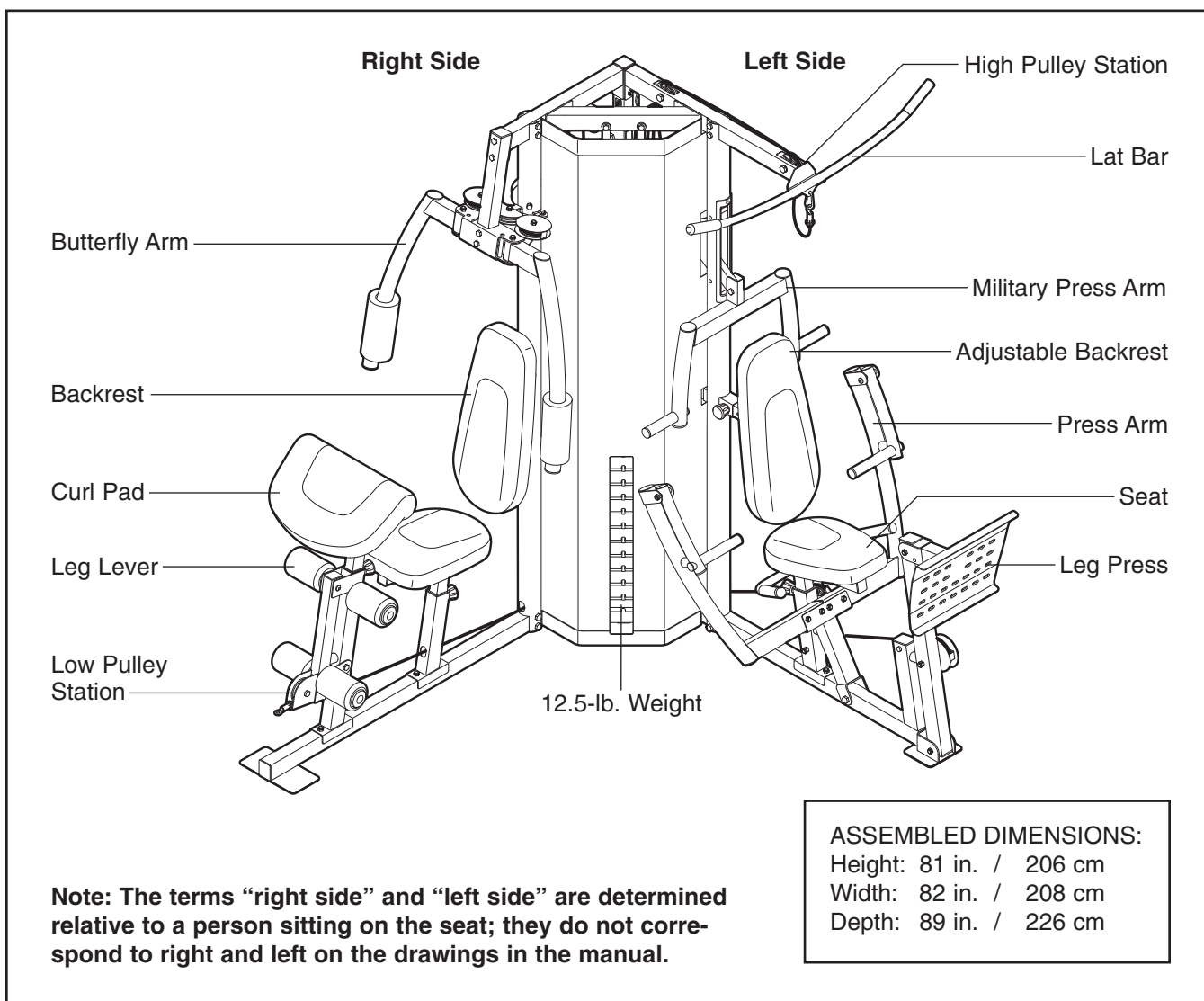

PART IDENTIFICATION CHART

Refer to the drawings below and on page 6 to identify small parts used in assembly. The number in parentheses by each drawing is the key number of the part, from the PART LIST on page 32 of this manual. **Note: Some small parts may have been pre-attached. If a part is not in the parts bag, check to see if it has been pre-attached.**

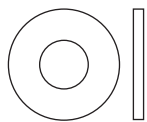

M6 Washer (90)

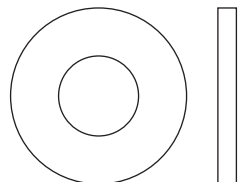

M10 Washer (108)



M6 Nylon Locknut (103)



M8 Nylon Locknut (101)

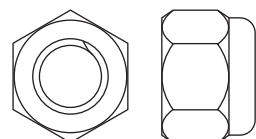

M10 Nylon Locknut (84)

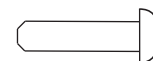

M4 x 16mm
Self-tapping
Screw (100)

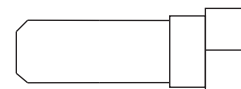

M8 x 25mm
Shoulder Bolt (92)

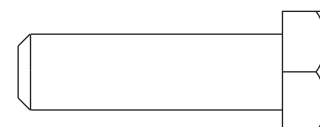

M10 x 35mm Screw (89)

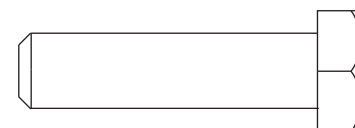

M10 x 40mm Bolt (104)

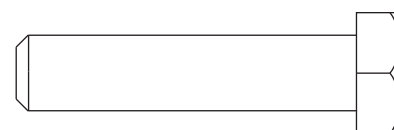

M10 x 45mm Bolt (95)

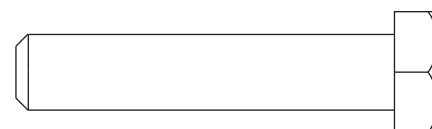

M10 x 50mm Bolt (105)

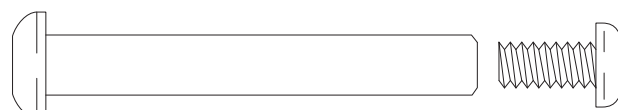

2 1/4" Bolt Set (86)

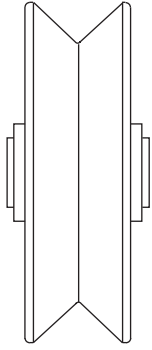

"V"-pulley (44)
(Not shown to scale)

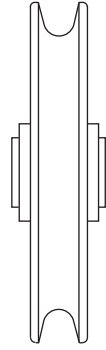

Pulley (43)
(Not shown to scale)

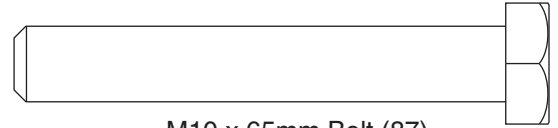

M10 x 65mm Bolt (87)

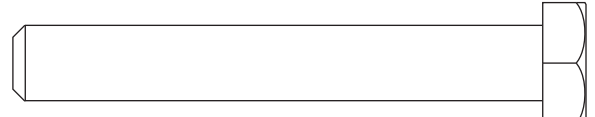

M10 x 70mm Bolt (57)

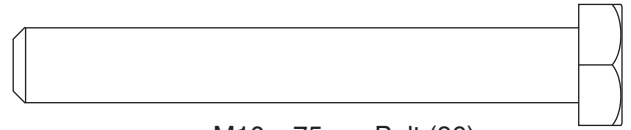

M10 x 75mm Bolt (96)

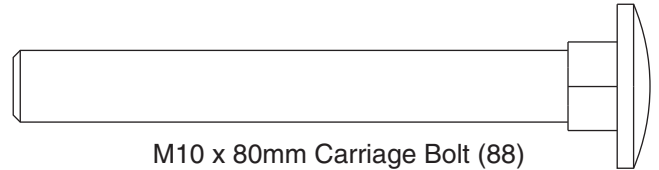

M10 x 80mm Carriage Bolt (88)

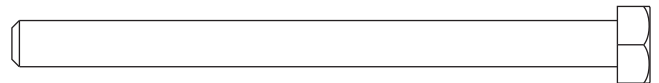

M6 x 80mm Screw (98)

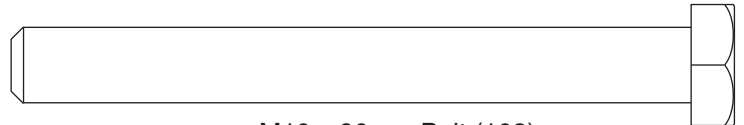

M10 x 90mm Bolt (102)

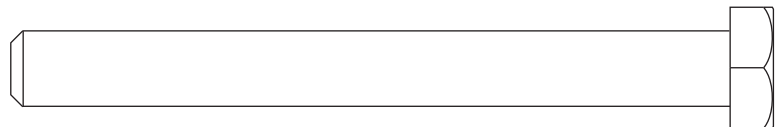

M10 x 95mm Bolt (107)

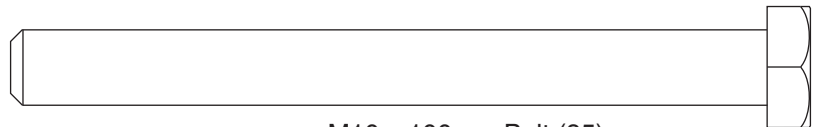

M10 x 100mm Bolt (85)

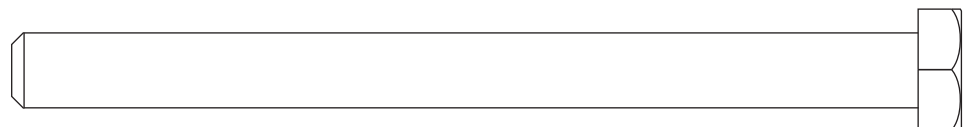

M10 x 120mm Bolt (97)

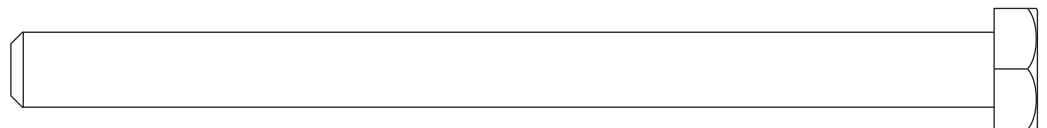

M10 x 130mm Bolt (106)

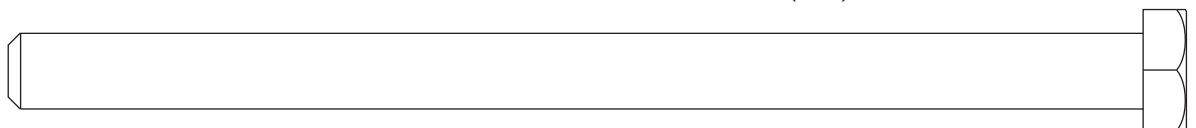

M10 x 150mm Bolt (94)

ASSEMBLY

Make Assembly Easier

Everything in this manual is designed to ensure that the weight system can be assembled successfully by almost anyone. **Before beginning assembly, make sure to read the information on this page. This brief introduction will save you much more time than it takes to read it.**

Hire an Authorized Service Technician

To hire an authorized service technician to assemble the weight system, call toll-free 1-800-445-2480.

Assembly Requires Two Persons

For your convenience and safety, assemble the weight system with the help of another person.

Set Aside Enough Time

Assembling the weight system may require several hours. By deciding to make the task enjoyable, assembly will go smoothly. You may want to assemble the weight system over a couple of evenings.

Select a Location for the Weight System





Because of its weight and size, the weight system should be assembled in the location where it will be used. Make sure that there is enough clearance to walk around the weight system as you assemble it.

How to Unpack the Box

To make assembly as easy as possible, we have divided the assembly process into four stages. The parts needed for each stage are found in individual packages. **Important: Wait until you begin each stage to open the parts package for that stage.** Place all parts of the weight system in a cleared

area and remove the packing materials. Do not dispose of the packing materials until assembly is completed.

The included hex keys  and grease, and the following tools (not included) may be required for assembly:

- Two adjustable wrenches 
- One standard screwdriver 
- One phillips screwdriver 
- One rubber mallet 
- A small amount of soapy water, and clear tape or masking tape.

Note: Assembly may be more convenient if you have a socket set, a set of open-end or closed-end wrenches, or a set of ratchet wrenches.

How to Identify Parts

Refer to the **PART IDENTIFICATION CHART** in the center of this manual to identify the small parts used in assembly. **Note: Some small parts may have been pre-attached. If a part is not in the parts bag, check to see if it has been pre-attached.**

How to Orient Parts

As you assemble the weight system, make sure all parts are oriented exactly as shown in the drawings.

Tightening Parts

Tighten all parts as you assemble them, unless instructed to do otherwise.

Questions?

If you have questions after reading the assembly instructions, please see the front cover of this manual.

The Four Stages of the Assembly Process

Frame Assembly—You will begin by assembling the base and the uprights that form the skeleton of the weight system.

Arm Assembly—During this stage you will assemble the arms and the moving parts.

Cable Assembly—During this stage you will attach the cables and pulleys that connect the arms to the weights.

Seat Assembly—During the final stage you will assemble the seats, the backrests, and other parts.

Frame Assembly

1. **Before beginning assembly, make sure you understand the information in the box on the previous page. For help identifying small parts, use the PART IDENTIFICATION CHART on pages 5 and 6 of this manual.**

Insert four M10 x 80mm Carriage Bolts (88) up through the Right Base (1). Place a piece of tape over the Bolt heads to hold the Carriage Bolts in place.

See the inset drawing. Insert two M10 x 80mm Carriage Bolts (88) up through the Left Base (2). Place a piece of tape over the Bolt heads to hold the Carriage Bolts in place.

2. Attach the Center Base (5) to the Right and Left Bases (1, 2) with four M10 x 70mm Bolts (57), four M10 Washers (108), and two M10 Nylon Locknuts (84). **Do not tighten the Bolts yet.**
3. Orient the Center Upright (9) so the 2" Square Inner Cap (51) is in the position shown. Attach the Center Upright to the Right and Left Bases (1, 2) with four M10 x 70mm Bolts (57), four M10 Washers (108), and two M10 Nylon Locknuts (84). **Do not tighten the Bolts yet.**

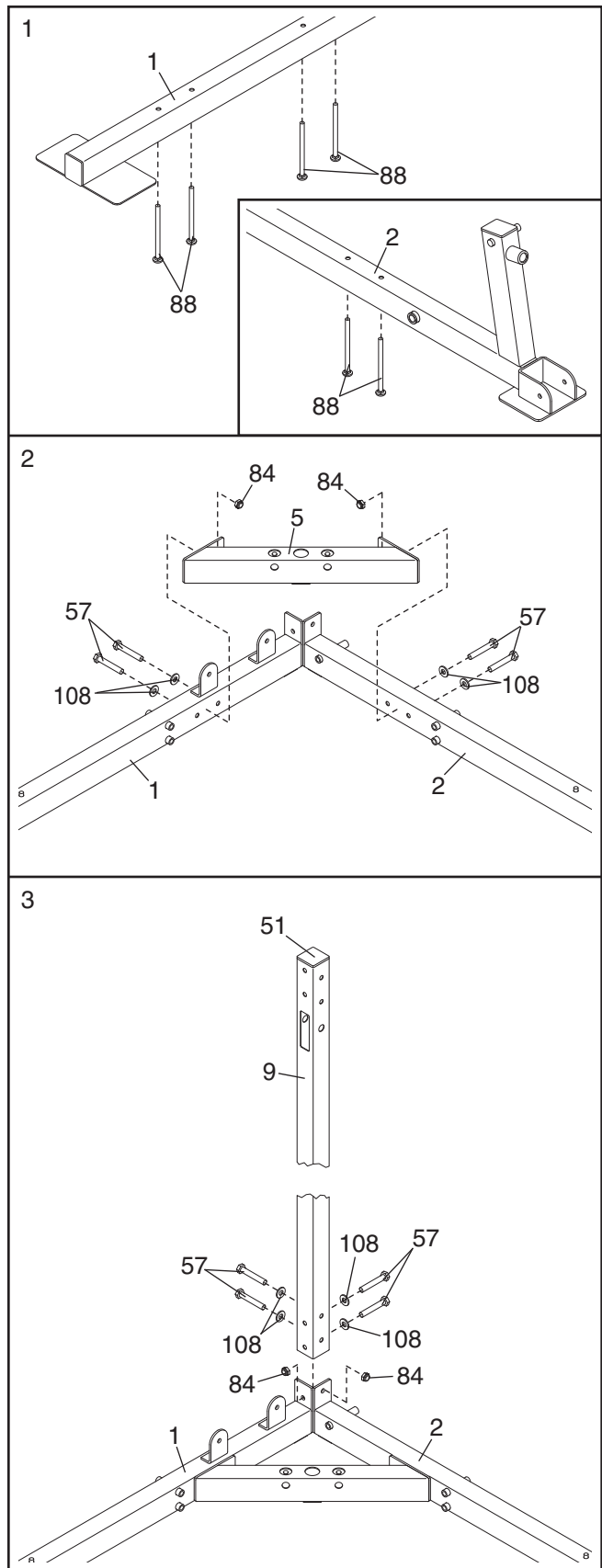

4. Attach the Right Upright (7) to the Right Base (1) with two M10 x 90mm Bolts (102) and two M10 Nylon Locknuts (84). **Do not tighten the Nylon Locknuts yet.**

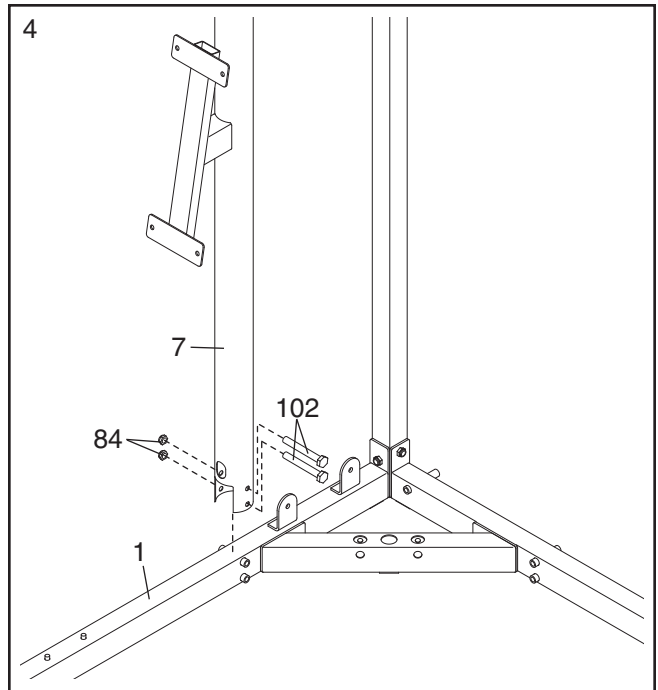

5. Attach the Right Seat Upright (11) to the Right Base (1) with the indicated M10 x 80mm Carriage Bolts (88) and two M10 Nylon Locknuts (84).

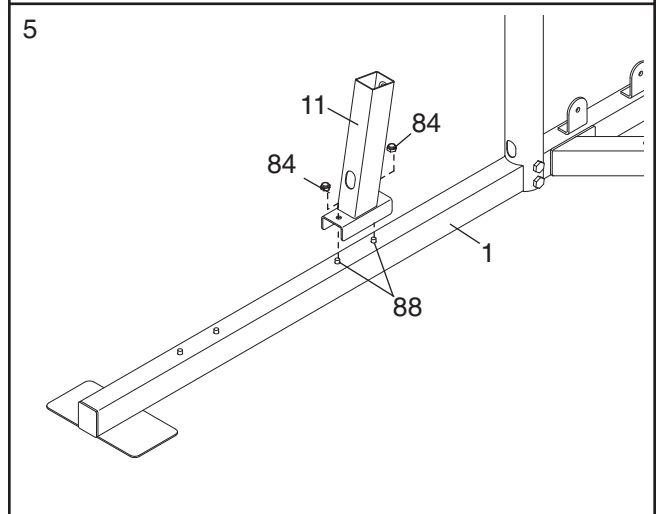

6. Attach the Curl Post Upright (10) to the Right Base (1) with the indicated M10 x 80mm Carriage Bolts (88) and two M10 Nylon Locknuts (84).

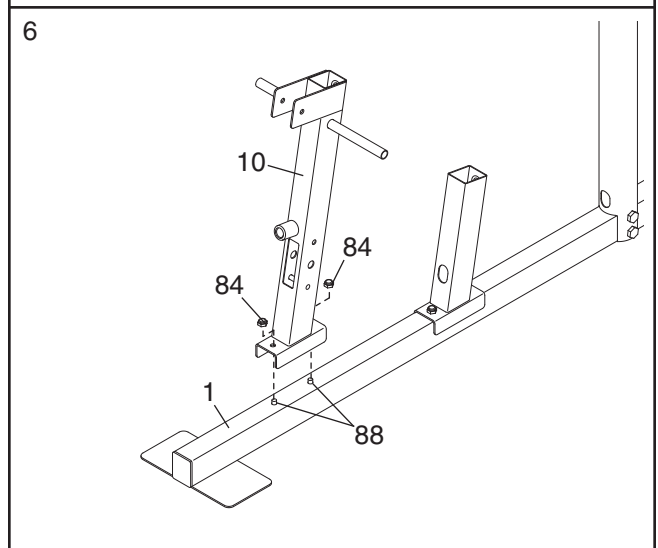

- Attach the Left Upright (8) to the Left Base (2) with two M10 x 90mm Bolts (102) and two M10 Nylon Locknuts (84). **Do not tighten the Nylon Locknuts yet.**

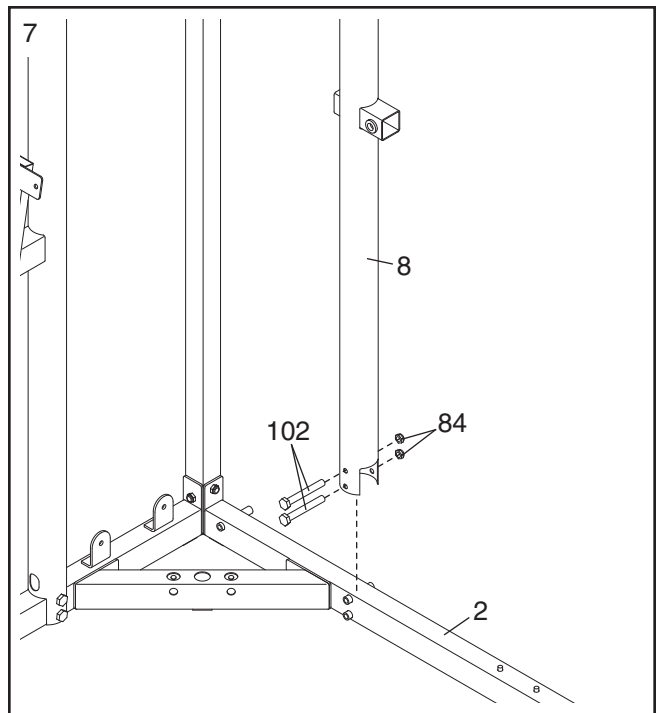

- Attach the Left Seat Upright (14) to the Left Base (2) with the indicated M10 x 80mm Carriage Bolts (88) and two M10 Nylon Locknuts (84).

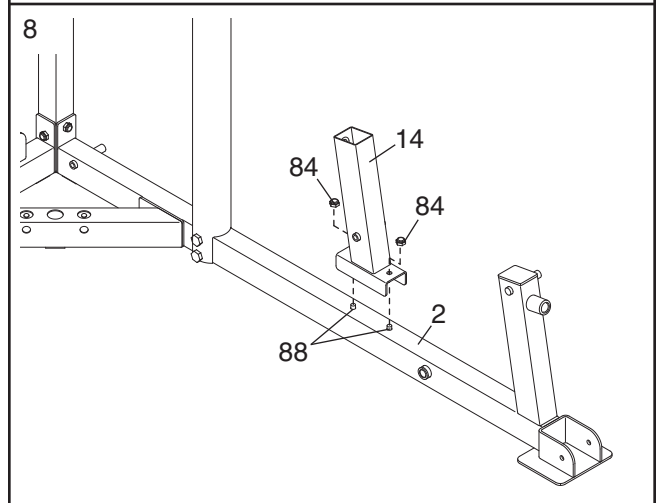

- Attach the Right Top Frame (3) to the Center Upright (9) with two M10 x 70mm Bolts (57), two M10 Washers (108), and an M10 Nylon Locknut (84). **Do not tighten the Bolts yet.**

Attach the Right Top Frame (3) to the Right Upright (7) with two M10 x 90mm Bolts (102) and two M10 Nylon Locknuts (84). **Do not tighten the Nylon Locknuts yet.**

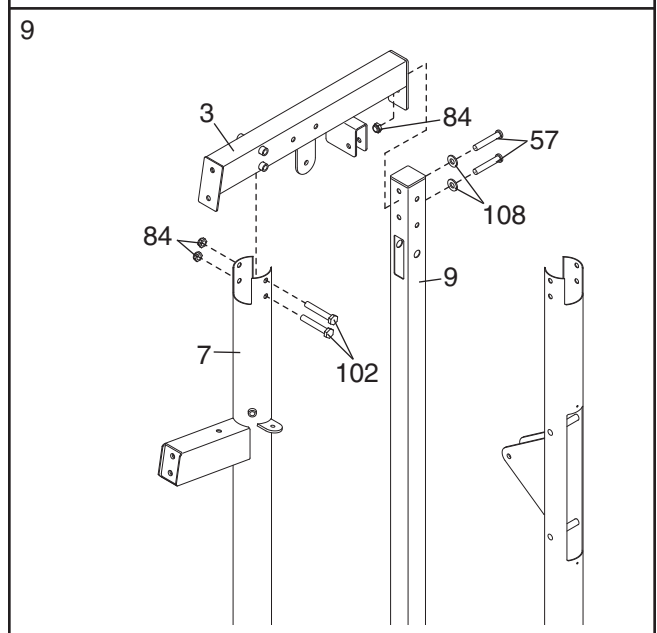

10. Attach the Left Top Frame (4) to the Center Upright (9) with two M10 x 70mm Bolts (57), two M10 Washers (108), and an M10 Nylon Locknut (84). **Do not tighten the Bolts yet.**

Attach the Left Top Frame (4) to the Left Upright (8) with two M10 x 90mm Bolts (102) and two M10 Nylon Locknuts (84). **Do not tighten the Nylon Locknuts yet.**

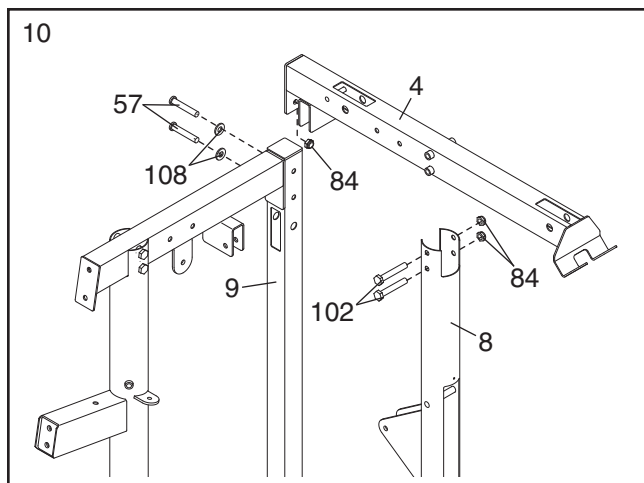

11. Attach the Butterfly Frame (24) to the Right Top Frame (3) with two M10 x 65mm Bolts (87) and an M10 Nylon Locknut (84). **Do not tighten the Bolts yet.**

Attach the Butterfly Frame (24) to the Right Upright (7) with two M10 x 35mm Screws (89). **Do not tighten the Screws yet.**

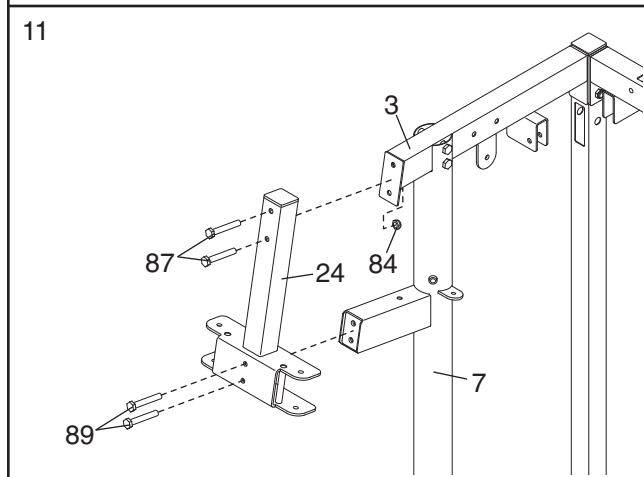

12. Orient a Weight Guide (30) with the indicated hole closer to the bottom. Attach the Weight Guide to the Center Base (5) with an M10 x 65mm Bolt (87), two M10 Washers (108), a 1/2" Bushing (68), and an M10 Nylon Locknut (84). Slide a Weight Bumper (66) onto the Weight Guide.

Attach the other Weight Guide (30) to the Center Base (5) in the same manner.

Tighten the M10 x 70mm Bolts (57) used in step 2.

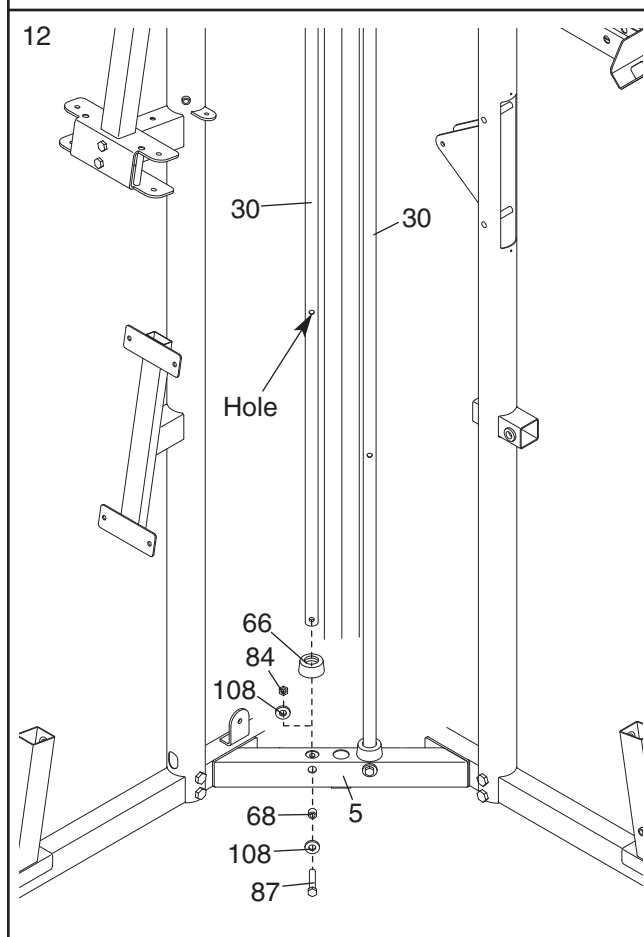

- Slide eleven 12.5-lb. Weights (34), with the pin grooves on the bottom, onto the Weight Guides (30).

Orient a Weight Tube (75) as shown. Insert the Weight Tube into the stack of Weights (34).

Slide another 12.5-lb. Weight (34) onto the Weight Guides (30).

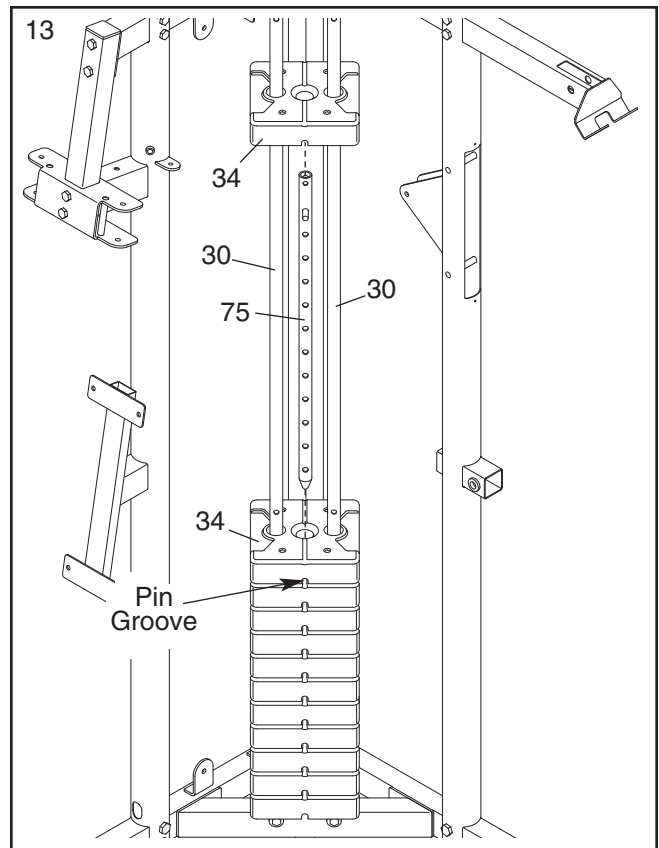

- Attach the Center Top Frame (6) to the Right and Left Top Frames (3, 4) with four M10 x 70mm Bolts (57), four M10 Washers (108), and two M10 Nylon Locknuts (84). **Do not tighten the Bolts yet.**

Attach a Weight Guide (30) inside the Center Top Frame (6) with an M10 x 65mm Bolt (87), two M10 Washers (108), a 1/2" Bushing (68), and an M10 Nylon Locknut (84).

Attach the other Weight Guide (30) to the Center Top Frame (6) in the same manner.

Tighten the bolts, screws and locknuts used in steps 3, 4, 7, 9, 10, 11, and 14.

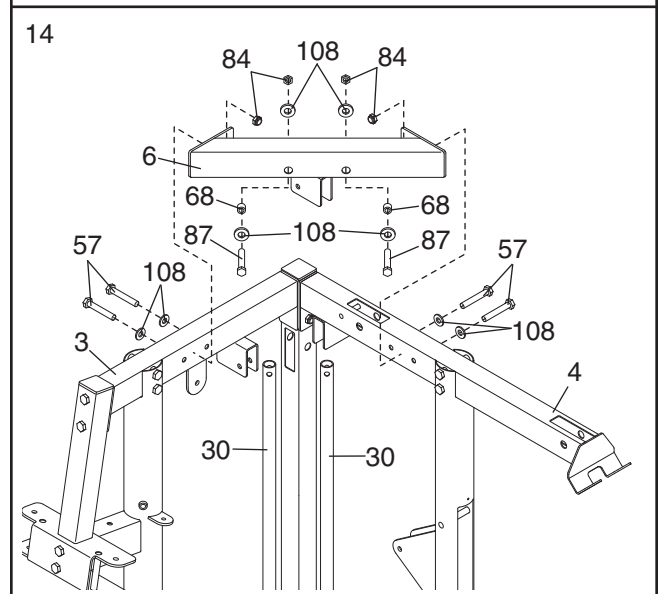

Arm Assembly

- Apply grease to a 2" Bushing (63) and insert the Bushing into the Leg Lever (15). Attach the Leg Lever and the Bushing to the Curl Post Upright (10) with a 2 1/4" Bolt Set (86).

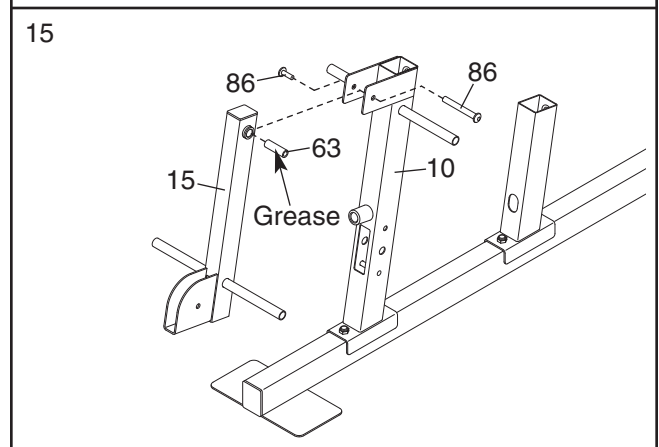

16. Apply grease to a 3" Bushing (71) and the two Large Round Bushings (61) in the Right Butterfly Arm (23). Next, insert the 3" Bushing into the Large Round Bushings. Attach the Butterfly Arm to the Butterfly Frame (24) with an M10 x 100mm Bolt (85) and an M10 Nylon Locknut (84).

Repeat this step with the Left Butterfly Arm (22).

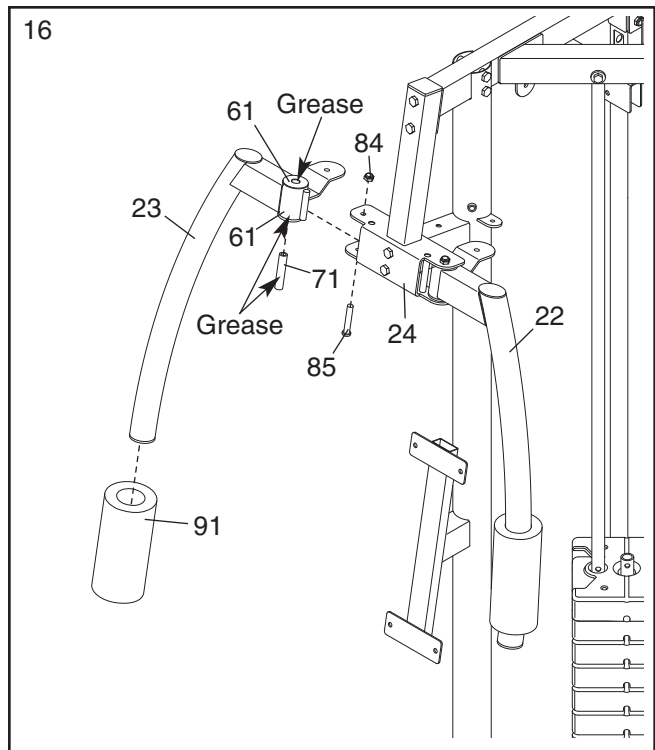

17. Apply grease to the 1 3/4" Bushing (64) and insert the Bushing into the Military Press Frame (20). Attach the Military Press Frame inside the Left Upright (8) with an M10 x 65mm Bolt (87) and an M10 Nylon Locknut (84).

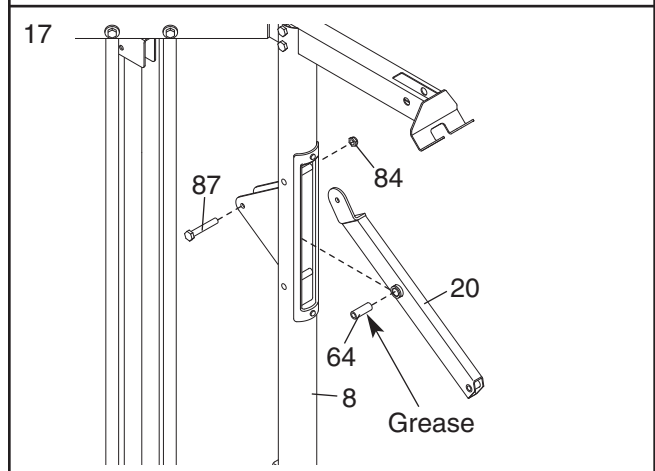

18. Apply grease to an M10 x 45mm Bolt (95). Attach the Military Press Arm (21) to the Military Press Frame (20) with the Bolt and an M10 Nylon Locknut (84). **Do not overtighten the Nylon Locknut; the Military Press Arm must be able to pivot easily.**

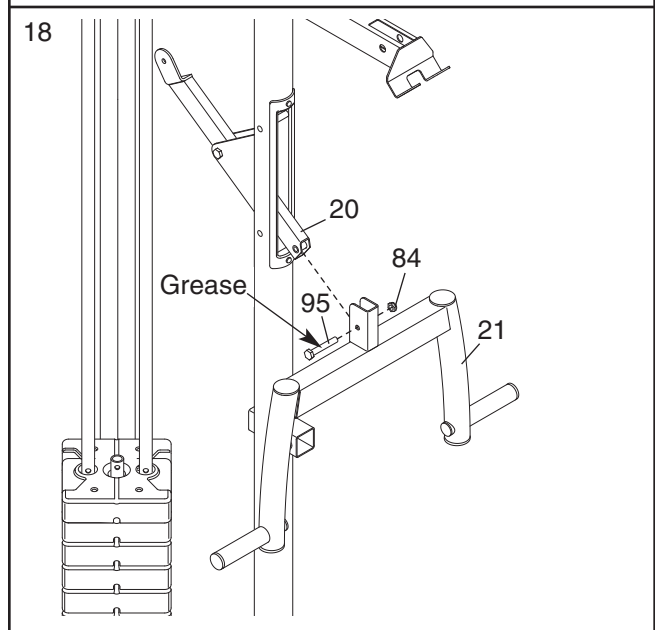

19. Apply grease to a 2 3/4" Bushing (65) and insert the Bushing into the Left Base (2). Attach the Press Frame (13) to the Left Base (2) with an M10 x 90mm Bolt (102) and an M10 Nylon Locknut (84).

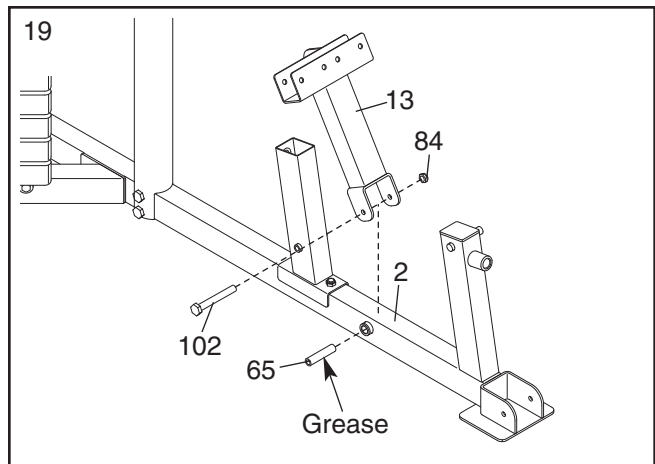

20. Attach the Right Press Arm (26) to the Press Frame (13) with two M10 x 70mm Bolts (57) and two M10 Nylon Locknuts (84).

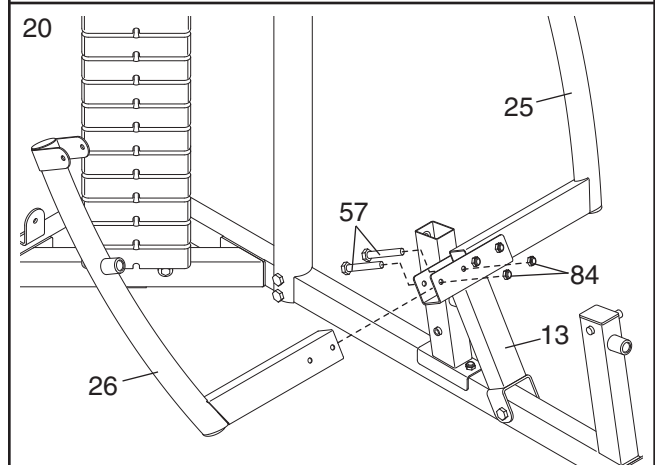

Attach the Left Press Arm (25) to the Press Frame (13) in the same manner.

21. Apply grease to an M10 x 70mm Bolt (57). Attach a Press Arm Handle (27) to the Right Press Arm (26) with the Bolt and an M10 Nylon Locknut (84). **Do not overtighten the Nylon Locknut; the Press Arm Handle must be able to pivot easily.**

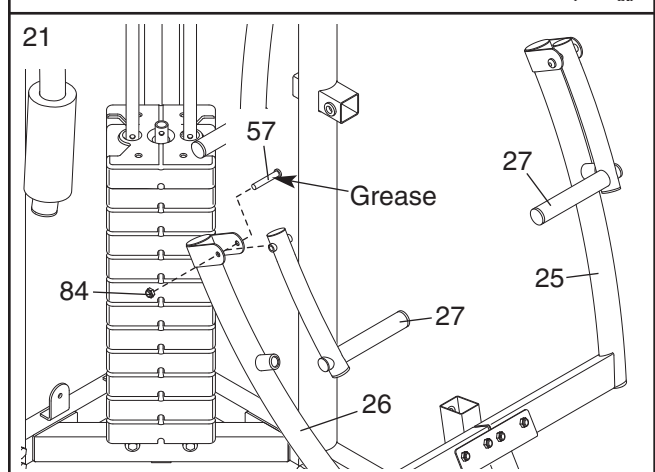

Repeat this step with the other Press Arm Handle (27) and the Left Press Arm (25).

22. Apply grease to a 2 3/4" Bushing (65) and insert the Bushing into the Press Leg (12). Next, orient the Leg Press with the welded spacer on the indicated side and attach the Leg Press to the Left Base (2) with an M10 x 95mm Bolt (107) and an M10 Nylon Locknut (84).

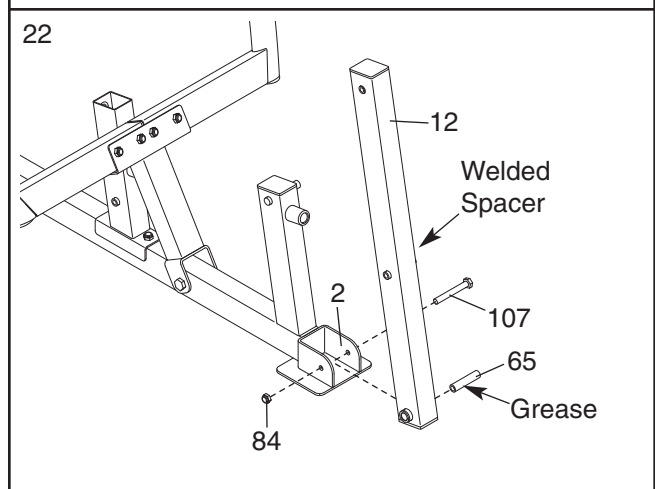

23. Apply grease to an M10 x 75mm Bolt (96). Attach the Leg Press Plate (29) to the Leg Press (12) with the Bolt and an M10 Nylon Locknut (84). **Do not overtighten the Nylon Locknut; the Leg Press Plate must be able to pivot easily.**

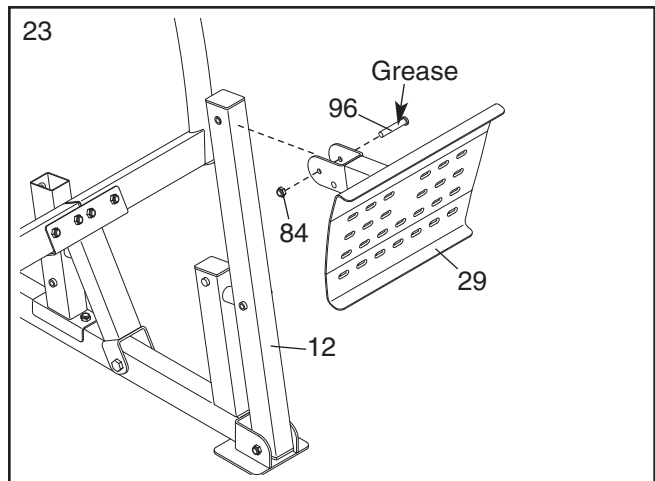

Cable Assembly

24. During steps 24–53, see the **CABLE DIAGRAM** on page 28 to identify the cables and ensure proper cable routing.

Identify the Butterfly Cable (73). Attach the Cable to the Right Upright (7) with an M8 x 25mm Shoulder Bolt (92) and an M8 Nylon Locknut (101). **Make sure that the Cable end can pivot easily around the shoulder of the Bolt.**

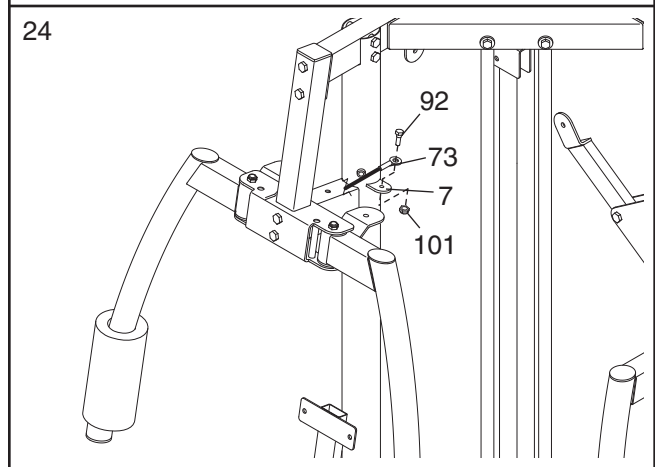

25. During steps 25–52, see the **PART IDENTIFICATION CHART** to identify the different types of pulleys.

Wrap the Butterfly Cable (73) around a Pulley (43). Attach the Pulley, a Cable Trap (48), an M10 Washer (108), and two Guards (45) to the Left Butterfly Arm (22) with an M10 x 50mm Bolt (105) and an M10 Nylon Locknut (84). **Make sure that the Cable Trap is oriented to hold the Cable in the groove of the Pulley.**

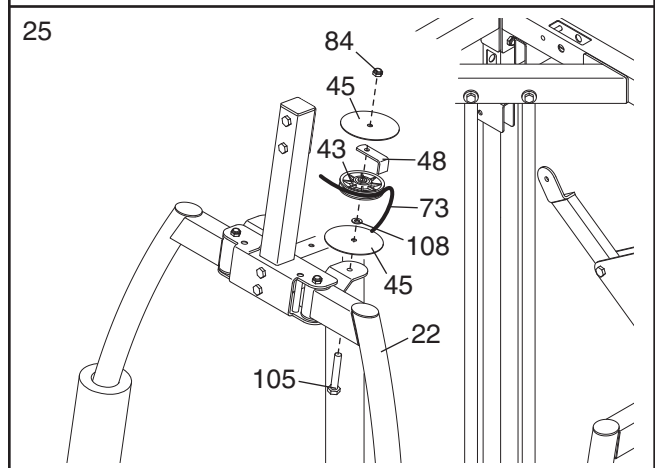

26. Wrap the Butterfly Cable (73) around a Pulley (43). Attach the Pulley, a Cable Trap (48), an M10 Washer (108), and two Half Guards (46) to the Right Upright (7) with an M10 x 120mm Bolt (97), an M10 Washer, and an M10 Nylon Locknut (84). **Make sure that the Cable Trap is oriented to hold the Cable in the groove of the Pulley. Make sure the Half Guards are oriented as shown.**

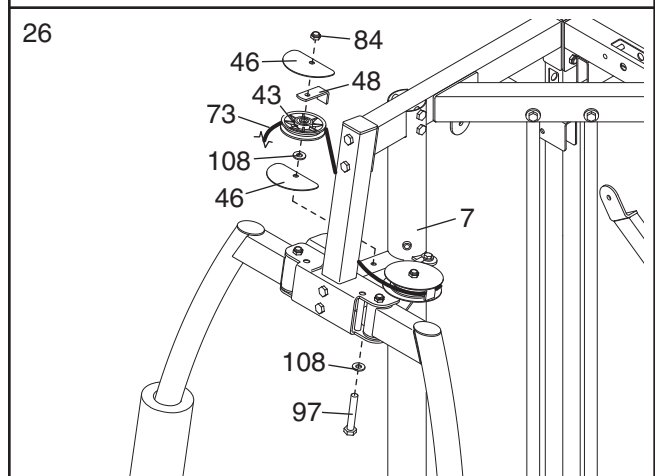

27. Wrap the Butterfly Cable (73) around a Pulley (43). Attach the Pulley, a Cable Trap (48), an M10 Washer (108), and two Guards (45) to the Right Butterfly Arm (23) with an M10 x 50mm Bolt (105) and an M10 Nylon Locknut (84). **Make sure that the Cable Trap is oriented to hold the Cable in the groove of the Pulley.**

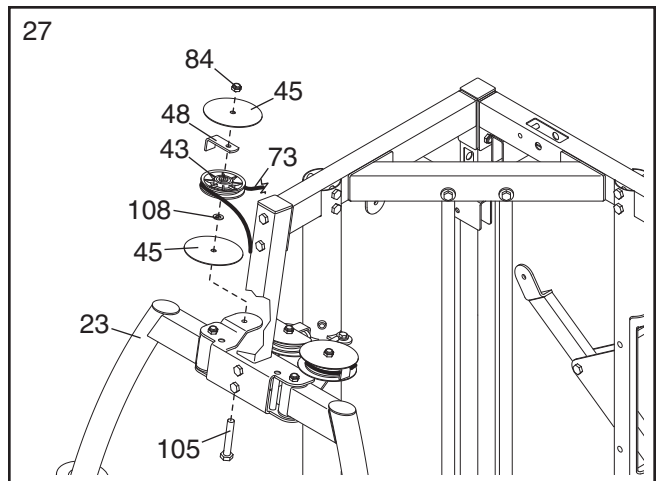

28. Wrap the Butterfly Cable (73) under a “V”-pulley (44). Attach the “V”-pulley, a Long Cable Trap (83), an M10 Washer (108), and two Guards (45) to the Right Upright (7) with an M10 x 150mm Bolt (94) and an M10 Nylon Locknut (84). **Make sure that the Cable Trap is oriented to hold the Cable in the groove of the “V”-pulley.**

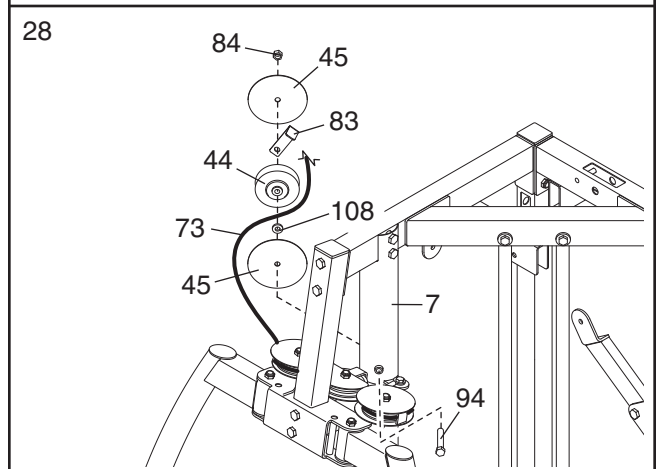

29. Wrap the Butterfly Cable (73) over a Pulley (43). Attach the Pulley to the Right Top Frame (3) with an M10 x 40mm Bolt (104) and an M10 Nylon Locknut (84).

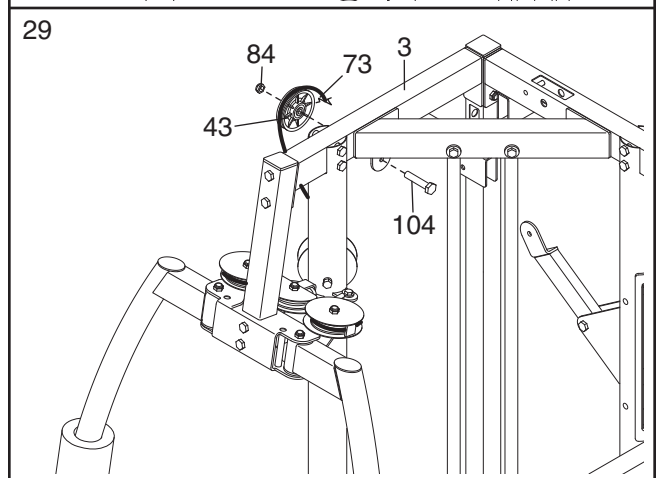

30. Wrap the Butterfly Cable (73) under a Pulley (43). Attach the Pulley, a Cable Trap (48), and two Half Guards (46) at the second hole from the top of the two Pulley Plates (49) with an M10 x 50mm Bolt (105) and an M10 Nylon Locknut (84). **Make sure that the Cable Trap is oriented to hold the Cable in the groove of the Pulley. Make sure the Half Guards are oriented as shown.**

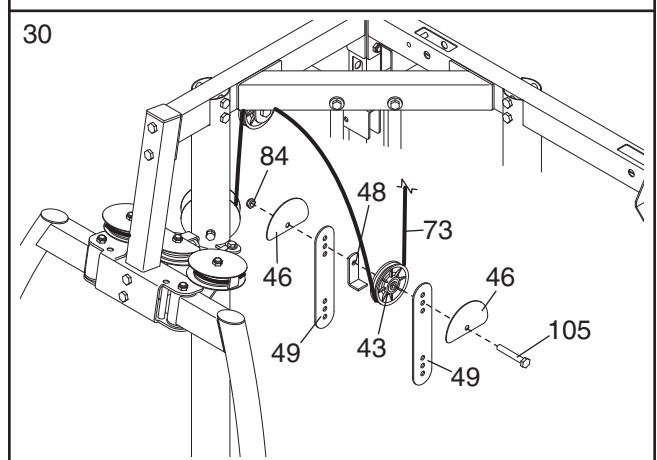

31. Wrap the Butterfly Cable (73) over a Pulley (43). Attach the Pulley to the Right Top Frame (3) with an M10 x 45mm Bolt (95) and an M10 Nylon Locknut (84).

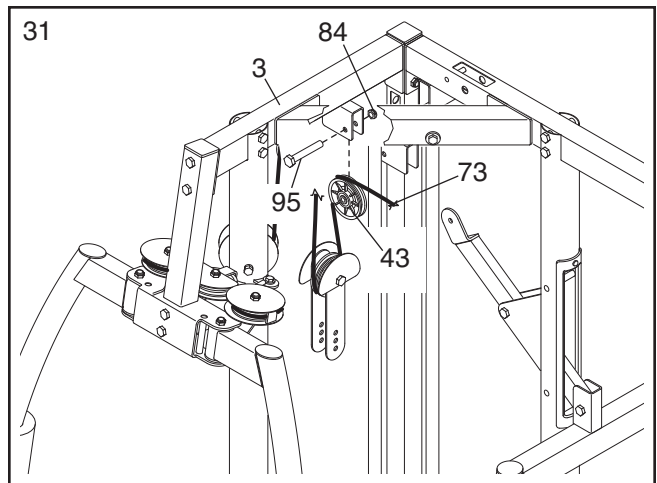

32. Wrap the Butterfly Cable (73) over a Pulley (43). Attach the Pulley to the Center Top Frame (6) with an M10 x 45mm Bolt (95) and an M10 Nylon Locknut (84).

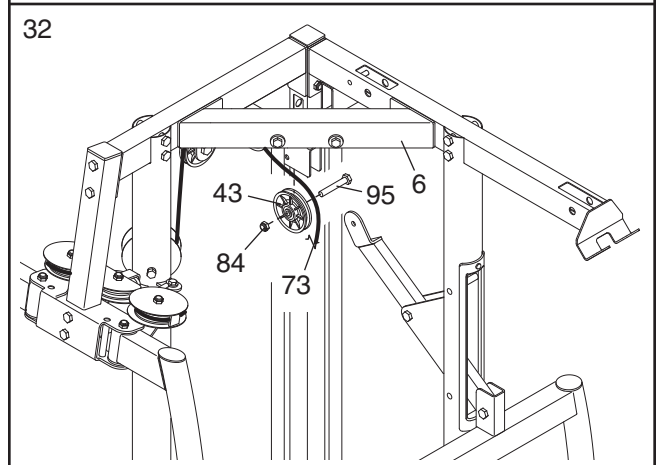

33. Attach the Butterfly Cable (73) and a Weight Cap (67) to the indicated Weight Tube (75) with an M10 x 50mm Bolt (105) and an M10 Nylon Locknut (84).

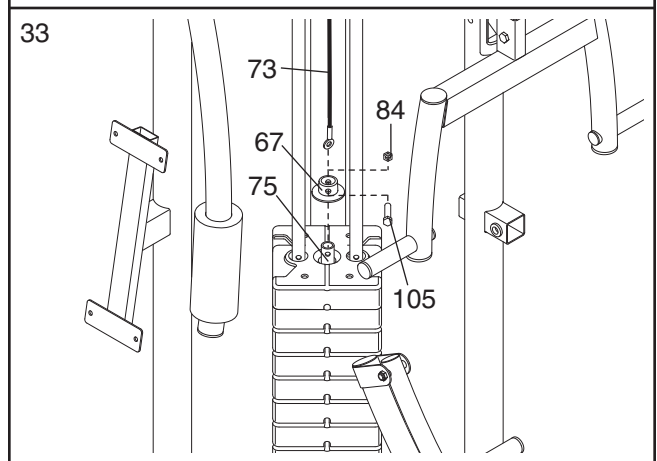

34. **Identify the Low Cable (70).** Route the Cable through the Leg Lever (15) and the Curl Post Upright (10).

Attach a Pulley (43) inside the Leg Lever (15), above the Low Cable (70), with an M10 x 45mm Bolt (95) and an M10 Nylon Locknut (84).

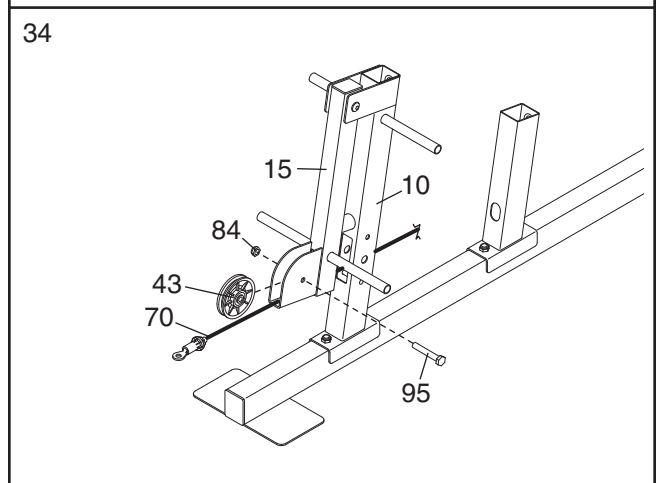

35. Attach a Pulley (43) inside the Curl Post Upright (10), above the Low Cable (70), with an M10 x 65mm Bolt (87), two M10 Washers (108), and two 1/2" Bushings (68), and an M10 Nylon Locknut (84).

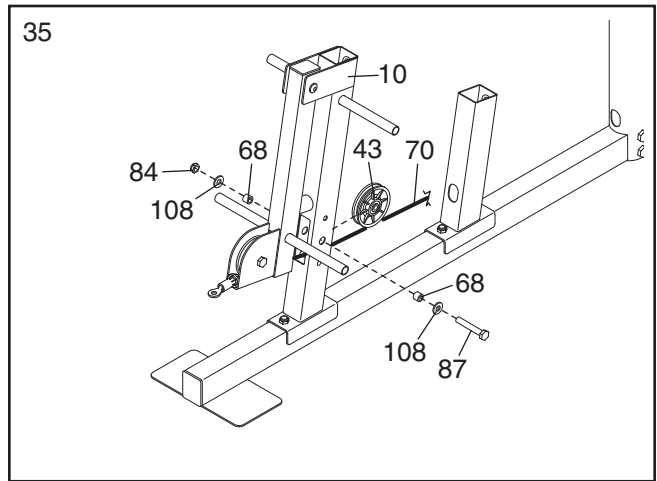

36. Route the Low Cable (70) through the Right Seat Upright (11) and the Right Upright (7) and under a Pulley (43). Attach the Pulley, an M10 Washer (108), and two Half Guards (46) to the Right Base (1) with an M10 x 45mm Bolt (95) and an M10 Nylon Locknut (84). **Make sure the Half Guards are oriented as shown.**

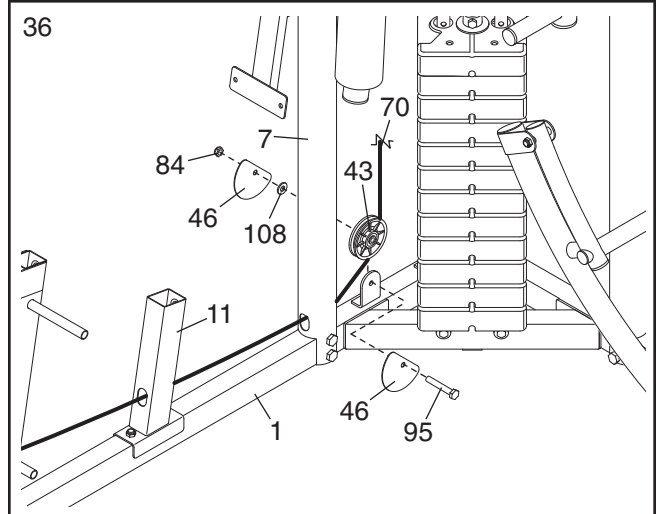

37. Wrap the Low Cable (70) over a Pulley (43). Attach the Pulley, a Cable Trap (48), and two Half Guards (46) at the second hole from the bottom of the two Pulley Plates (49) with an M10 x 50mm Bolt (105) and an M10 Nylon Locknut (84). **Make sure that the Cable Trap is oriented to hold the Cable in the groove of the Pulley. Make sure the Half Guards are oriented as shown.**

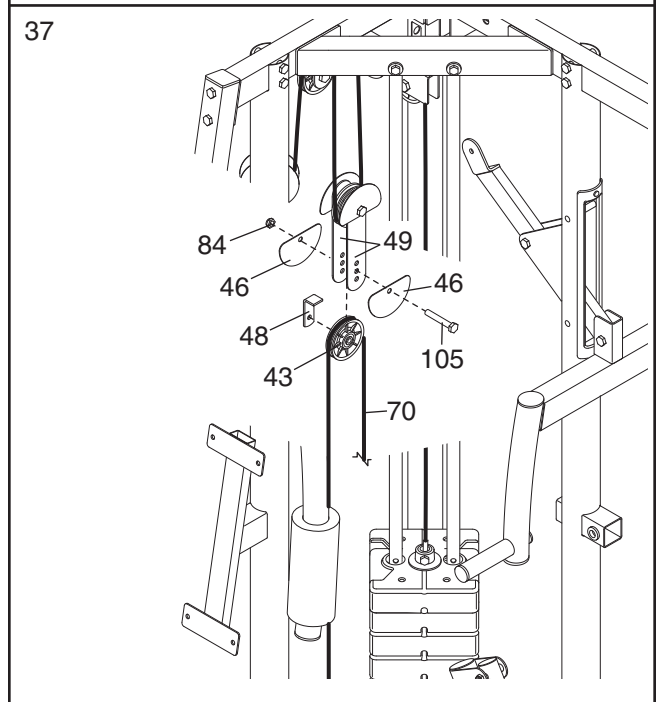

38. Wrap the Low Cable (70) under a Pulley (43). Attach the Pulley, an M10 Washer (108), and two Half Guards (46) to the Right Base (1) with an M10 x 45mm Bolt (95) and an M10 Nylon Locknut (84). **Make sure the Half Guards are oriented as shown.**

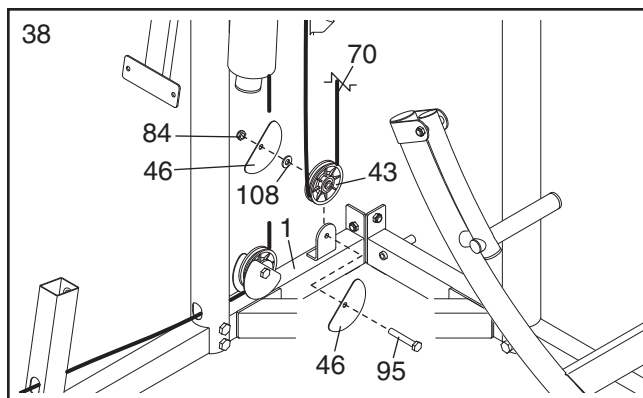

39. Route the Low Cable (70) over a Pulley (43) and through the Center Upright (9). Attach the Pulley inside the Center Upright with an M10 x 65mm Bolt (87), two M10 Washers (108), two 1/2" Bushings (68), and an M10 Nylon Locknut (84).

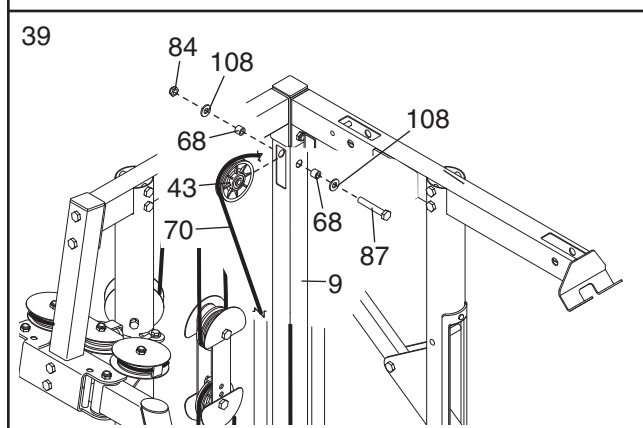

40. Wrap the Low Cable (70) under a Pulley (43). Attach the Pulley, a Cable Trap (48), and a Guard (45) to the Small Pulley Plate (50) with an M10 x 50mm Bolt (105) and an M10 Nylon Locknut (84). **Make sure that the Cable Trap is oriented to hold the Cable in the groove of the Pulley.**

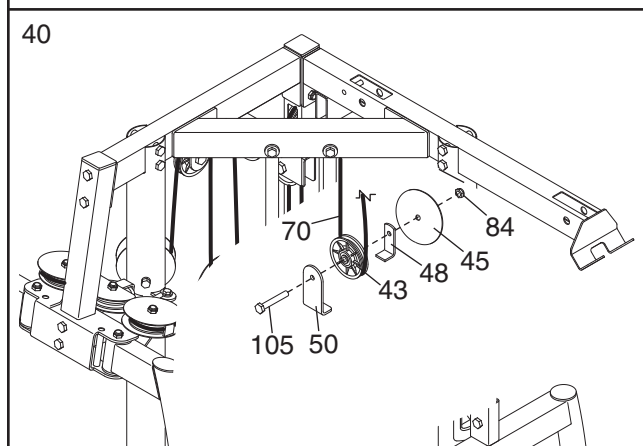

41. Wrap the Low Cable (70) over a Pulley (43). Attach the Pulley to the Left Top Frame (4) with an M10 x 45mm Bolt (95) and an M10 Nylon Locknut (84).

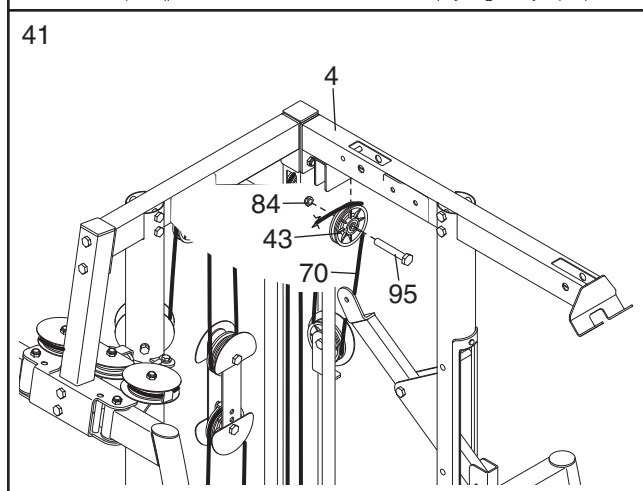

42. Wrap the Low Cable (70) under a Pulley (43). Attach the Pulley to the Military Press Frame (20) with an M10 x 40mm Bolt (104) and an M10 Nylon Locknut (84).

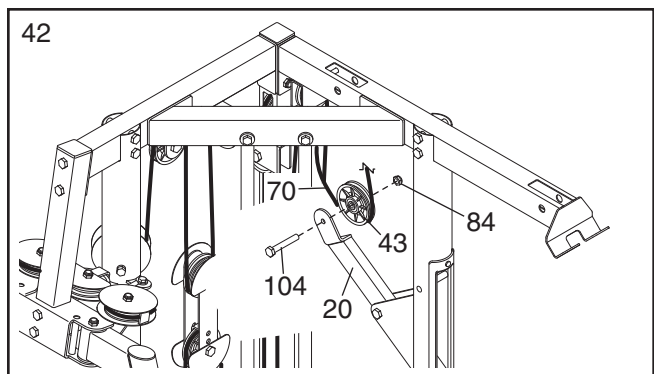

43. Route the Low Cable (70) up through the Left Top Frame (4) and over a Pulley (43). Attach the Pulley inside the Left Top Frame with an M10 x 65mm Bolt (87), two M10 Washers (108), two 1/2" Bushings (68), and an M10 Nylon Locknut (84).

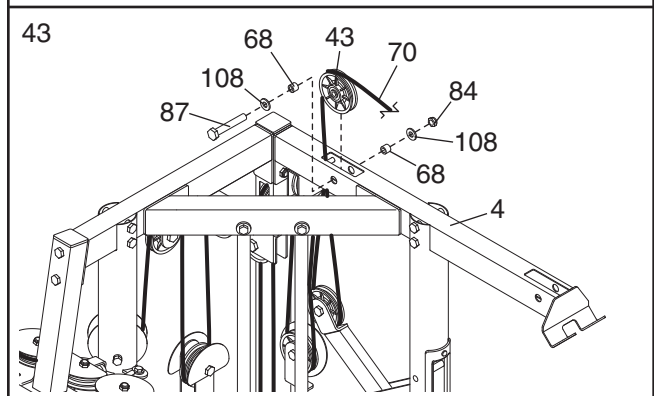

44. Wrap the Low Cable (70) over a Pulley (43) and down through the Left Top Frame (4). Attach the Pulley inside the Left Top Frame with an M10 x 65mm Bolt (87), two M10 Washers (108), two 1/2" Bushings (68), and an M10 Nylon Locknut (84).

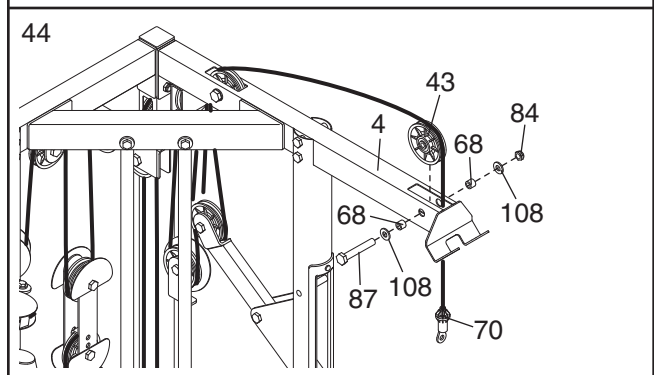

45. **Identify the Press Cable (72).** Attach the Cable to the Left Base (2) with an M8 x 25mm Shoulder Bolt (92). **Make sure that the Cable end can pivot easily around the shoulder of the Bolt.**

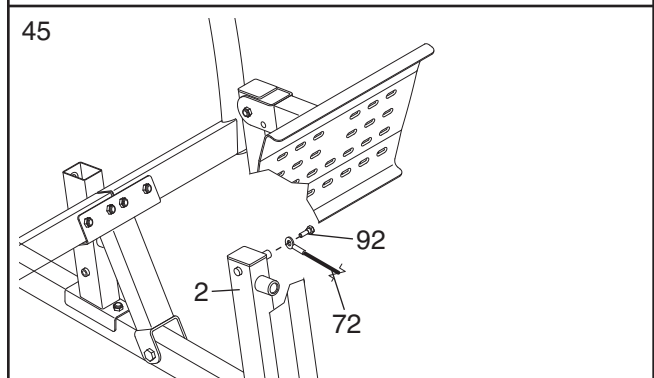

46. Wrap the Press Cable (72) over a Pulley (43). Attach the Pulley, a Cable Trap (48), an M10 Washer (108), and two Guards (45) to the Leg Press (12) with an M10 x 120mm Bolt (97) and an M10 Nylon Locknut (84). **Make sure that the Cable Trap is oriented to hold the Cable in the groove of the Pulley.**

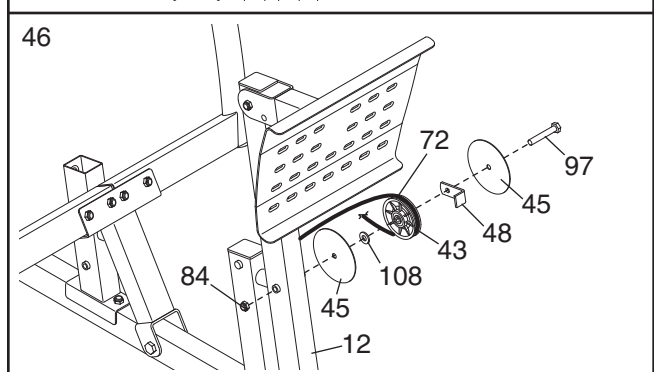

47. Wrap the Press Cable (72) under a Pulley (43). Attach the Pulley, a Cable Trap (48), an M10 Washer (108), and two Half Guards (46) to the Left Seat Upright (14) with an M10 x 120mm Bolt (97) and an M10 Nylon Locknut (84). **Make sure that the Cable Trap is oriented to hold the Cable in the groove of the Pulley. Make sure the Half Guards are oriented as shown.**

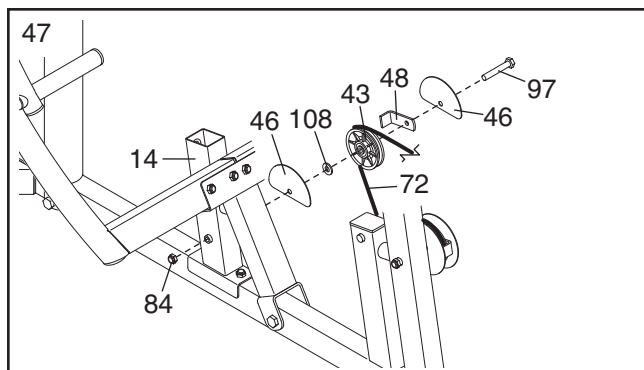

48. **Note: This step is shown from the opposite side of the Press Frame (13).**

Wrap the Press Cable (72) under a Pulley (43). Attach the Pulley, a Cable Trap (48), an M10 Washer (108), and two Half Guards (46) to the Press Frame (13) with an M10 x 45mm Bolt (95) and an M10 Nylon Locknut (84). **Make sure that the Cable Trap is oriented to hold the Cable in the groove of the Pulley. Make sure the Half Guards are oriented as shown.**

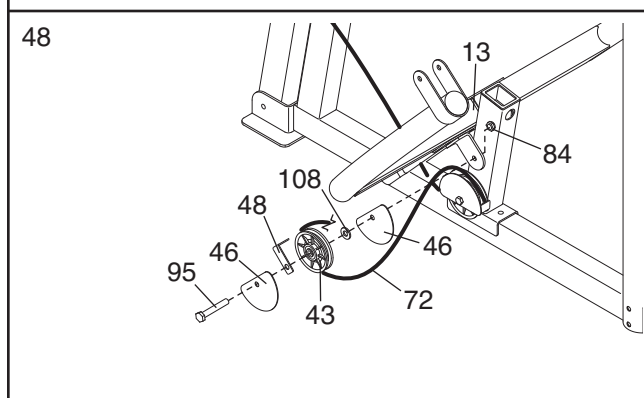

49. Wrap the Press Cable (72) under a Pulley (43). Attach the Pulley, a Cable Trap (48), an M10 Washer (108), and two Half Guards (46) to the Left Base (2) with an M10 x 130mm Bolt (106) and an M10 Nylon Locknut (84). **Make sure that the Cable Trap is oriented to hold the Cable in the groove of the Pulley. Make sure the Half Guards are oriented as shown.**

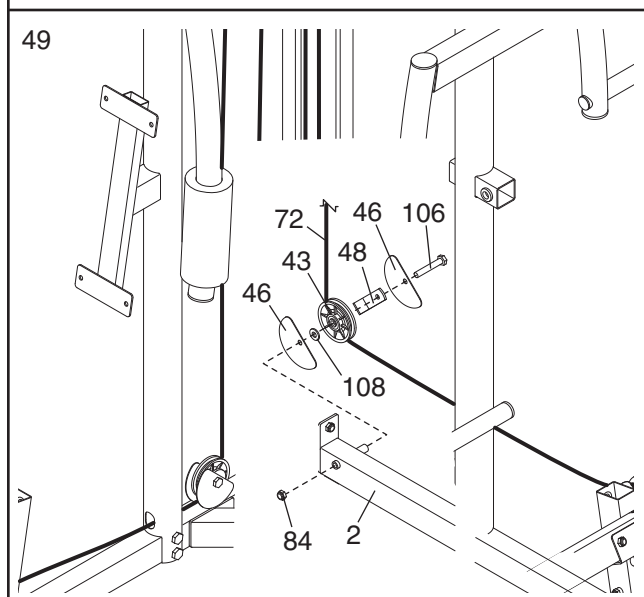

50. Attach the Press Cable (72) to the Small Pulley Plate (50) with an M6 Washer (90) and an M6 Nylon Locknut (103). **See the inset drawing. Do not completely tighten the Nylon Locknut; it should be tightened so that only two threads of the Cable show past the Nylon Locknut.**

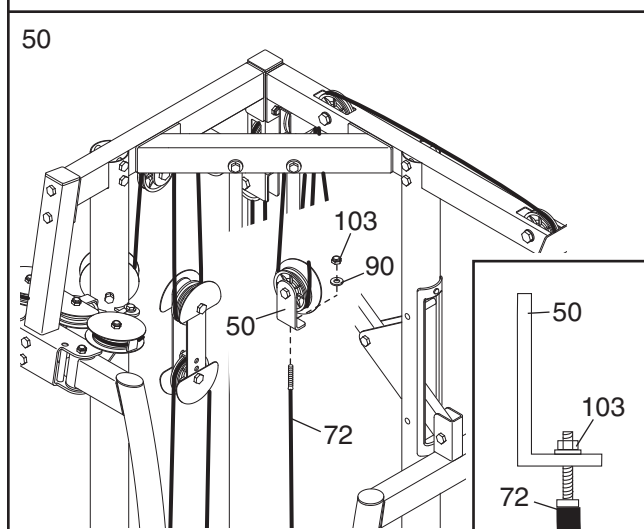

Seat Assembly

51. Attach a Backrest (35) to the Right Upright (7) with four M6 x 16mm Screws (99).

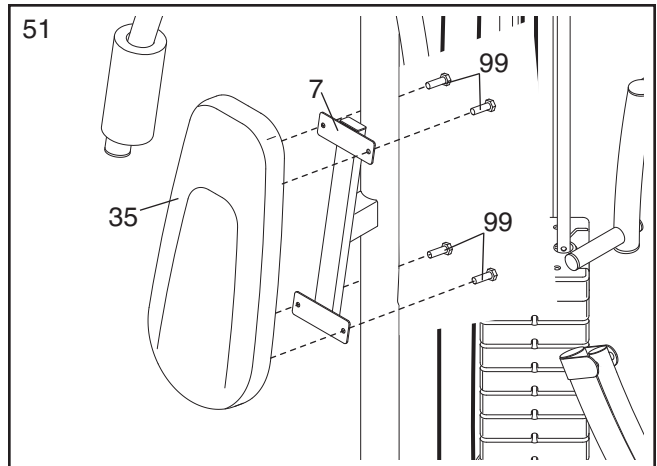

52. Attach the Large Seat (37) to the Right Seat Frame (17) with two M6 x 16mm Screws (99), an M6 x 80mm Screw (98), and an M6 Washer (90).

Attach the Small Seat (not shown) to the Left Seat Frame (not shown) in the same manner.

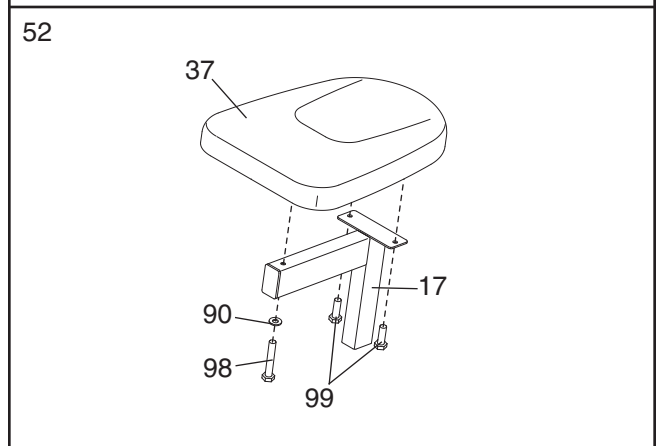

53. Tighten an Adjustment Knob (69) into the Right Seat Upright (11). Insert the Right Seat Frame (17) into the Right Seat Upright and engage the Adjustment Knob into the Right Seat Frame.

Repeat this step with the Left Seat Frame (not shown) and the Left Seat Upright (not shown).

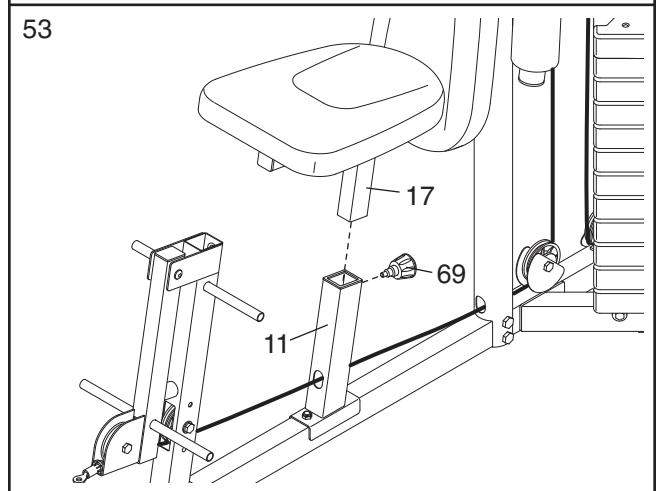

54. Attach a Backrest (35) to the Backrest Frame (19) with four M6 x 16mm Screws (99).

Tighten an Adjustment Knob (69) into the Left Upright (8). Insert the Backrest Frame (19) into the Left Upright and engage the Adjustment Knob into the Backrest Frame.

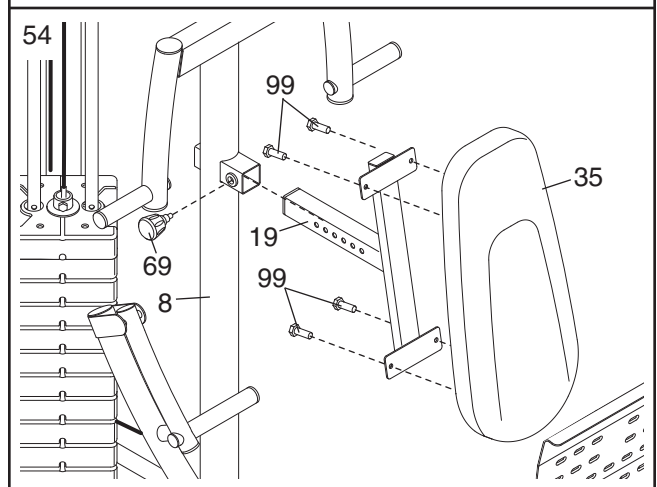

55. Attach the Shroud (32) to the Right Upright (7) with six M4 x 16mm Self-tapping Screws (100).

Attach the Shroud (32) to the Left Upright (8) in the same manner.

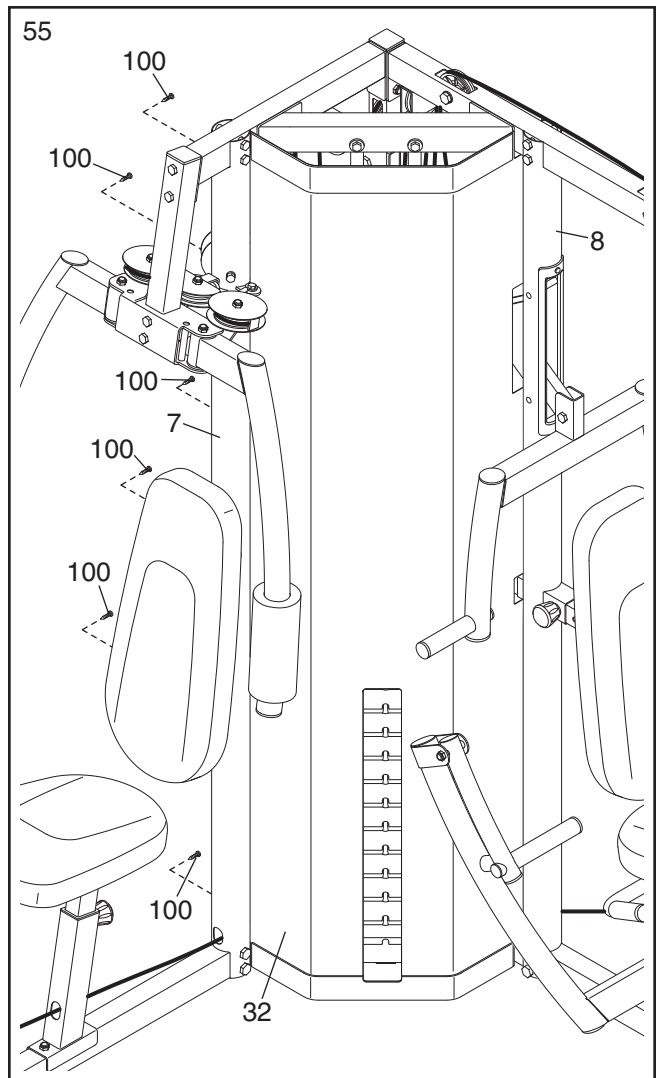

56. Attach the Leg Lever Lock (47) to the Curl Post Upright (10) with an M10 x 70mm Bolt (57), an M10 Washer (108), and an M10 Nylon Locknut (84). **Do not overtighten the Nylon Locknut; the Leg Lever Lock must be able to pivot easily.**

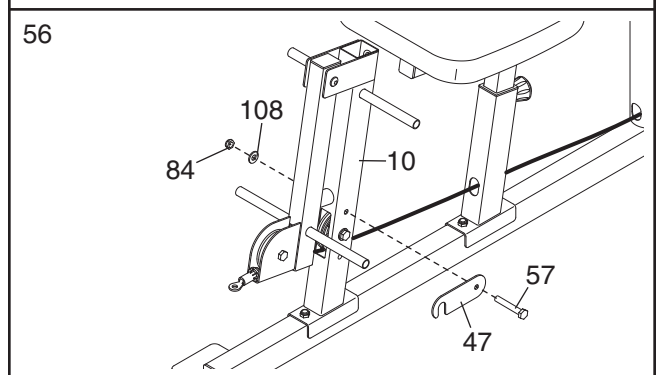

57. Slide four Foam Pads (39) onto the Curl Post Upright (10) and the Leg Lever (15). Press four 3/4" Round Inner Caps (58) into the ends of the Foam Pads.

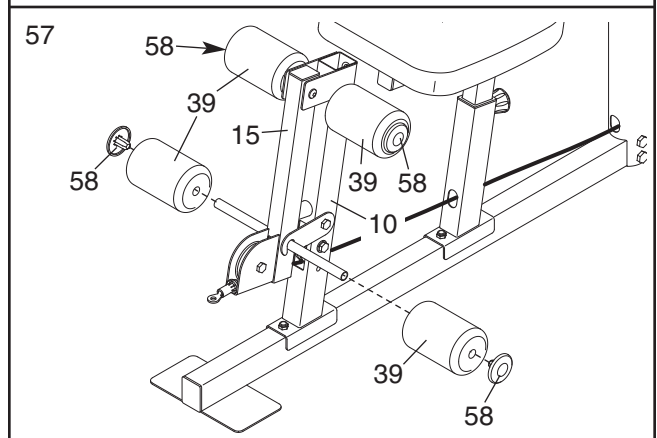

58. Attach the Curl Pad (38) to the Curl Post (16) with two M6 x 16mm Screws (99).

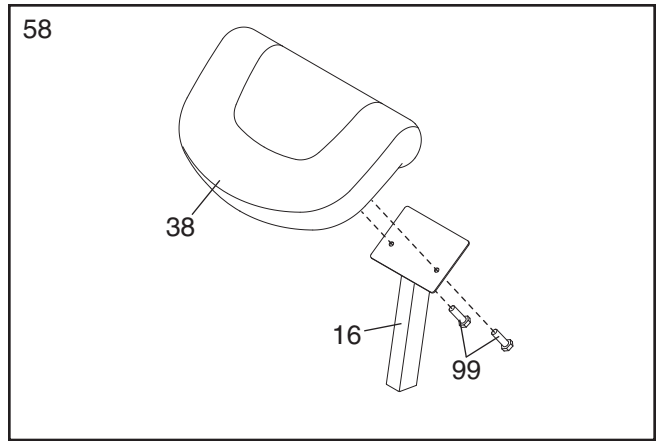

59. Make sure that all parts have been properly tightened. The use of the remaining parts will be explained in ADJUSTMENTS, beginning on page 25.

Before using the weight system, pull each cable a few times to make sure that the cables move smoothly over the pulleys. If one of the cables does not move smoothly, find and correct the problem. **IMPORTANT: If the cables are not properly installed, they may be damaged when heavy weight is used. See the CABLE DIAGRAM on page 28 of this manual for proper cable routing. If there is any slack in the cables, you will need to remove the slack by tightening the cables (see page 26).**

ADJUSTMENTS

This section explains how to adjust the weight system. See the EXERCISE GUIDELINES on page 29 for important information about how to get the most benefit from your exercise program. Also, refer to the accompanying exercise guide to see the correct form for each exercise.

Make sure all parts are properly tightened each time the weight system is used. Replace any worn parts immediately. The weight system can be cleaned with a damp cloth and a mild, non-abrasive detergent. Do not use solvents.

CHANGING THE WEIGHT SETTING

To change the setting of the weight stack, insert the Weight Pin (93) under the desired 12.5-lb. Weight (34). Insert the Weight Pin so that the bent end touches the weight stack. Turn the bent end down.

Note: Due to the cables and pulleys, the amount of resistance at each exercise station may vary from the weight setting.

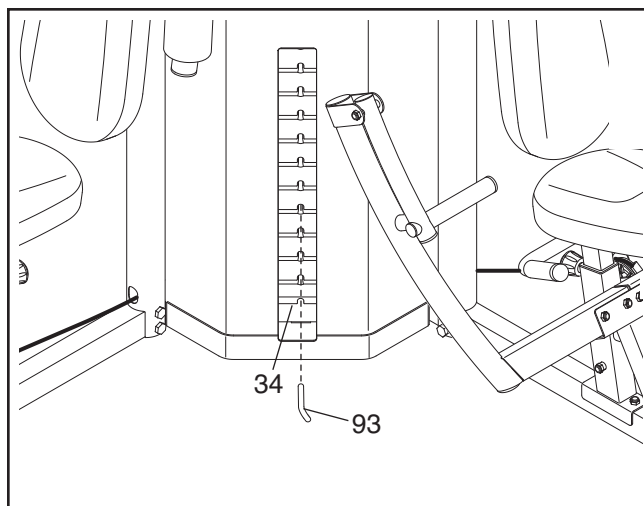

ATTACHING THE LAT BAR

Attach the Lat Bar (74) to the Low Cable (70) with a Weight Clip (81). For some exercises, the Chain (82) should be attached between the Lat Bar and the Cable with two Weight Clips. **Adjust the length of the Chain between the Lat Bar and the Cable so that the Lat Bar is in the correct starting position for the exercise to be performed.**

The Lat Bar (74) or the Ankle Strap (not shown) can be attached to the Low Cable (70) at the low pulley station (not shown) in the same manner. When using the low pulley station, always engage the Leg Lever Lock (47 see USING THE LEG LEVER LOCK on page 27).

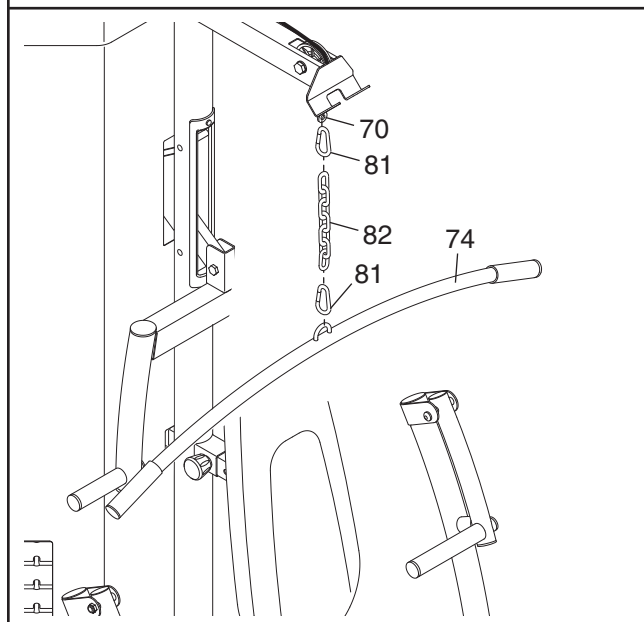

ADJUSTING THE BACKREST

To adjust the position of the left Backrest (35), first loosen the indicated Adjustment Knob (69) and disengage it from the Backrest Frame (19). Next, move the Backrest to the desired position. Reengage the Knob into the Backrest Frame and retighten the Knob into the Left Upright (8). **Make sure the Knob is fully tightened.**

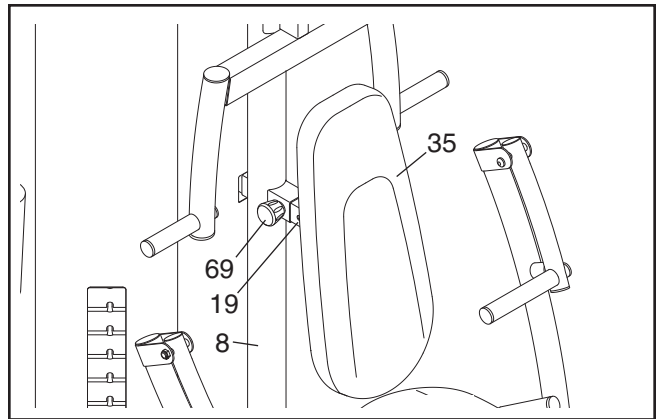

ADJUSTING THE SEATS

To adjust the position of the Large Seat (37), loosen the indicated Adjustment Knob (69) and disengage it from the Right Seat Frame (17). Next, move the Seat to the desired position. Reengage the Knob into the Right Seat Frame and retighten the Knob into the Right Seat Upright (11). **Make sure the Knob is fully tightened.**

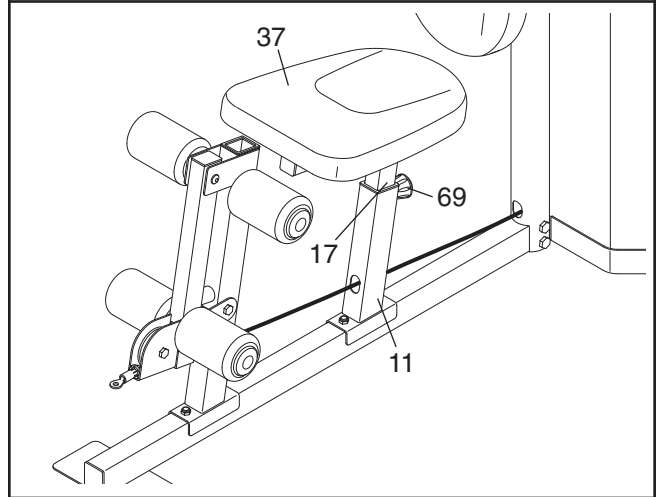

The Small Seat (not shown) can be adjusted in the same manner.

ATTACHING THE CURL PAD

Insert the Curl Post (16) into the Curl Post Upright (10) and secure it at the desired height with an Adjustment Knob (69). Remove the Curl Pad (38) from the weight system when performing an exercise that does not require it. **Note: You may need to lower the Large Seat (37, see ADJUSTING THE SEATS above) to remove the Adjustment Knob.**

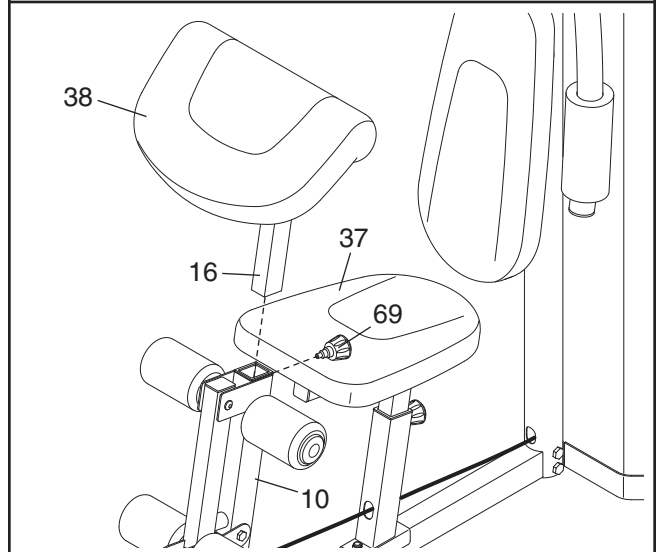

LOCKING THE WEIGHT STACK

Lock the weight stack by inserting a Lock Pin (78) through a Weight Guide (30) and securing the Lock (77) onto the Lock Pin.

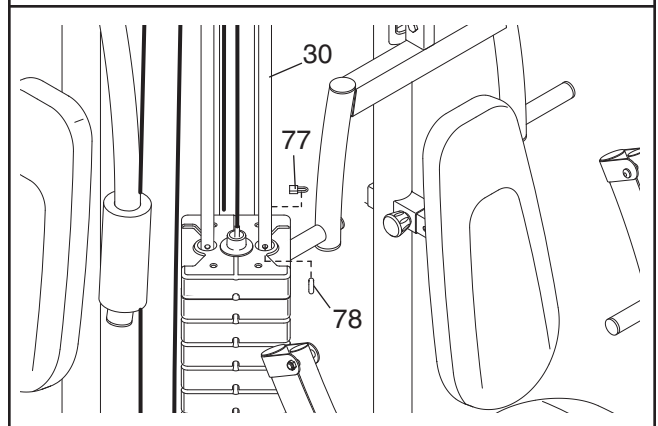

USING THE LEG LEVER LOCK

When using the low pulley station, engage the Leg Lever Lock (47) onto the Leg Lever (15) tube.

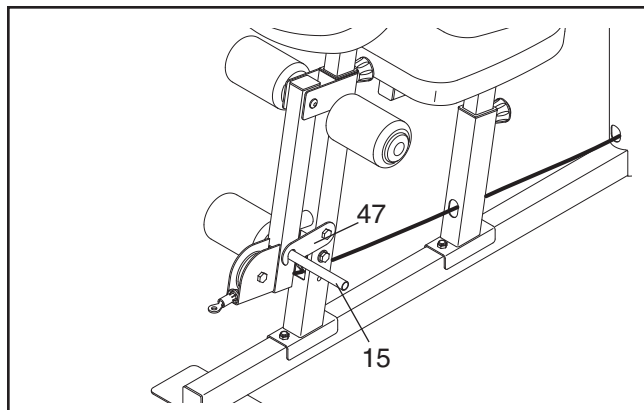

TIGHTENING THE CABLES

Woven cable, the type of cable used on the weight system, can stretch slightly when it is first used. If there is slack in the cables before resistance is felt, the cables should be tightened. To tighten the cables, first insert the weight pin into the middle of the weight stack. Slack can be removed from these cables in several ways:

See drawing A. Remove the M10 Nylon Locknut (84) and the M10 x 50mm Bolt (105) from the indicated Pulley (43), Cable Trap (48), Half Guards (46), and Pulley Plates (49). Reattach the Pulley, Cable Trap, and Half Guards using a hole closer to the center of the Pulley Plates. **Make sure that the Cable Trap is oriented to hold the cable in the groove of the Pulley, that the Half Guards are oriented as shown, and that the Cable and Pulley move smoothly.** Adjust the top Pulley (43) in the same manner, if necessary.

See drawing B. To remove slack from the Press Cable (72), tighten the M6 Nylon Locknut (103) further onto the end of the Press Cable (72).

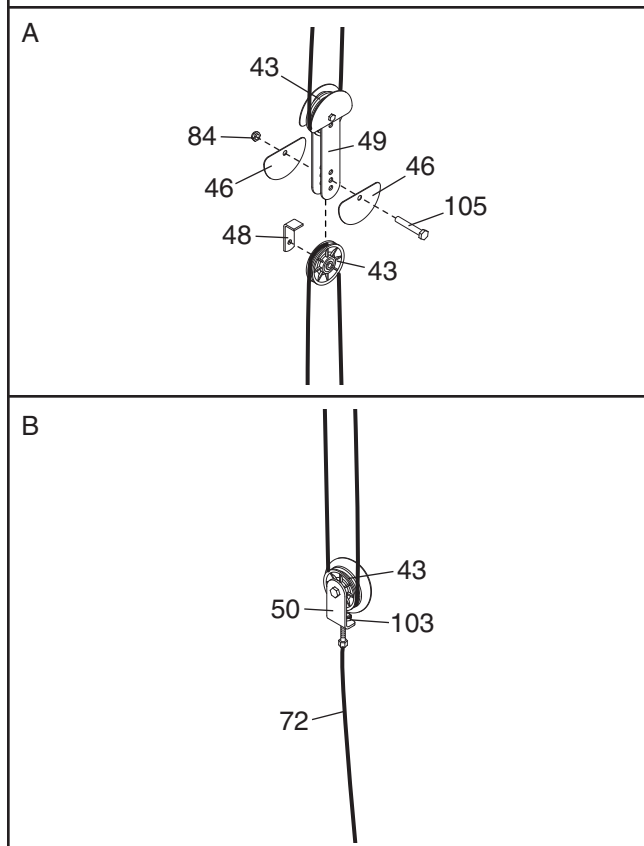

CABLE DIAGRAM

The cable diagrams below show the proper routing of the Low Cable (70), the Press Cable (72), and the Butterfly Cable (73). Use the diagrams to make sure that the cables, the cable traps, and the guards have been assembled correctly. If the cables have not been correctly routed, the weight system will not function properly and damage may occur. The numbers show the correct route for each cable. **Make sure that the cable traps do not touch or bind the cables.**

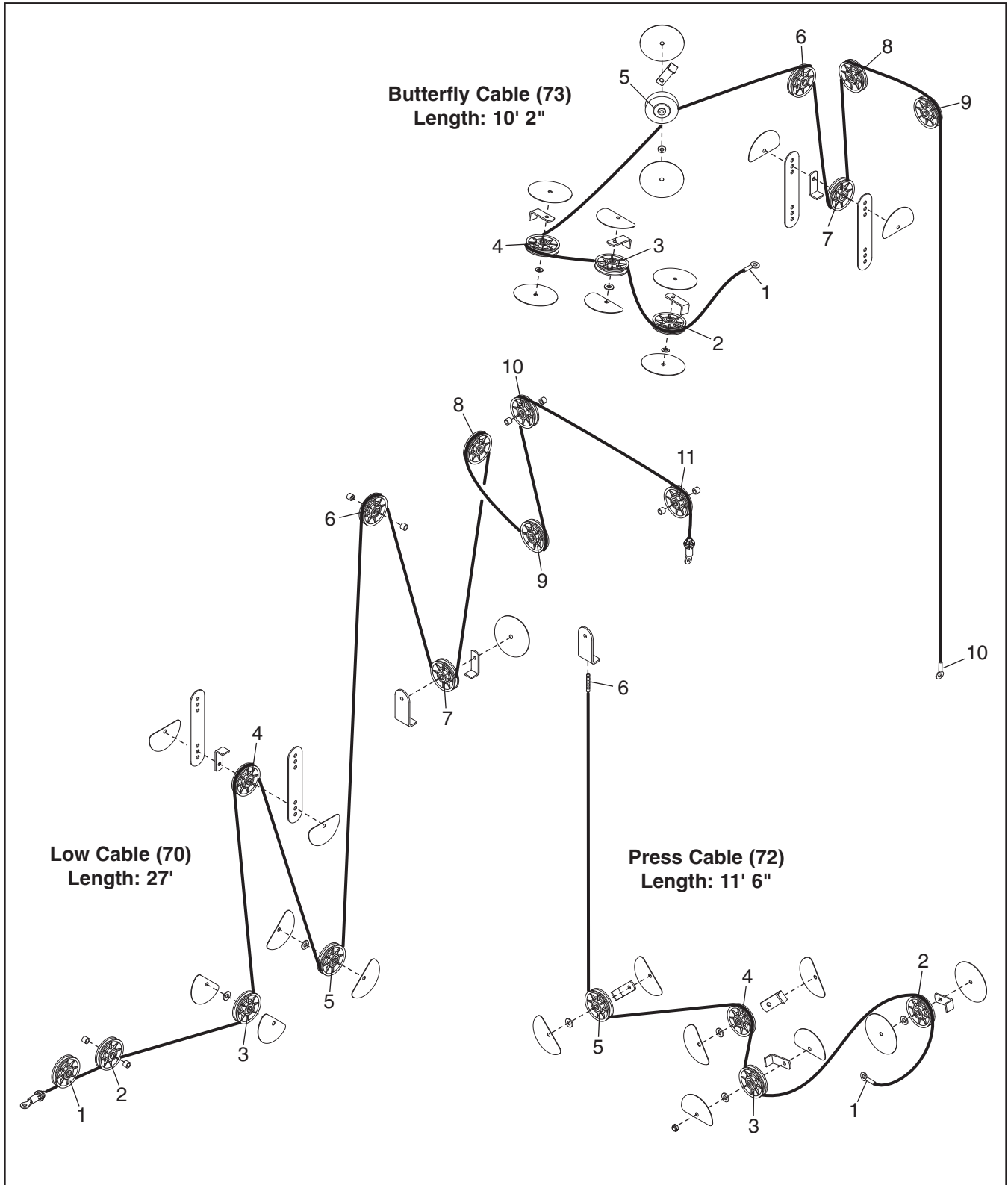

EXERCISE GUIDELINES

THE FOUR BASIC TYPES OF WORKOUTS

Muscle Building

To increase the size and strength of your muscles, push them close to their maximum capacity. Your muscles will adapt and grow as you progressively increase the intensity of your exercise. You can adjust the intensity level of an individual exercise in two ways:

- by changing the amount of weight used
- by changing the number of repetitions or sets performed. (A “repetition” is one complete cycle of an exercise, such as one sit-up. A “set” is a series of repetitions.)

The proper amount of weight for each exercise depends upon the individual user. You must gauge your limits and select the amount of weight that is right for you. Begin with 3 sets of 8 repetitions for each exercise you perform. Rest for 3 minutes after each set. When you can complete 3 sets of 12 repetitions without difficulty, increase the amount of weight.

Toning

You can tone your muscles by pushing them to a moderate percentage of their capacity. Select a moderate amount of weight and increase the number of repetitions in each set. Complete as many sets of 15 to 20 repetitions as possible without discomfort. Rest for 1 minute after each set. Work your muscles by completing more sets rather than by using high amounts of weight.

Weight Loss

To lose weight, use a low amount of weight and increase the number of repetitions in each set. Exercise for 20 to 30 minutes, resting for a maximum of 30 seconds between sets.

Cross Training

Cross training is an efficient way to get a complete and well-balanced fitness program. An example of a balanced program is:

- Plan strength training workouts on Monday, Wednesday, and Friday.
- Plan 20 to 30 minutes of aerobic exercise, such as running on a treadmill or riding an exercise cycle, on Tuesday and Thursday.
- Rest from both strength training and aerobic exercise for at least one full day each week to give your body time to regenerate.

The combination of strength training and aerobic exercise will reshape and strengthen your body, plus develop your heart and lungs.

PERSONALIZING YOUR EXERCISE PROGRAM

Determining the exact length of time for each workout, as well as the number of repetitions or sets completed, is an individual matter. It is important to avoid overdoing it during the first few months of your exercise program. You should progress at your own pace and be sensitive to your body’s signals. If you experience pain or dizziness at any time while exercising, stop immediately and begin cooling down. Find out what is wrong before continuing. Remember that adequate rest and a proper diet are important factors in any exercise program.

WARMING UP

Begin each workout with 5 to 10 minutes of stretching and light exercise to warm up. Warming up prepares your body for more strenuous exercise by increasing circulation, raising your body temperature and delivering more oxygen to your muscles.

WORKING OUT

Each workout should include 6 to 10 different exercises. Select exercises for every major muscle group, emphasizing areas that you want to develop most. To give balance and variety to your workouts, vary the exercises from session to session.

Schedule your workouts for the time of day when your energy level is the highest. Each workout should be followed by at least one day of rest. Once you find the schedule that is right for you, stick with it.

EXERCISE FORM

Maintaining proper form is an essential part of an effective exercise program. This requires moving through the full range of motion for each exercise, and moving only the appropriate parts of the body. Exercising in an uncontrolled manner will leave you feeling exhausted. On the exercise guide accompanying this manual you will find photographs showing the correct form for several exercises, and a list of the muscles affected. Refer to the muscle chart on the next page to find the names of the muscles.

The repetitions in each set should be performed smoothly and without pausing. The exertion stage of each repetition should last about half as long as the return stage. Proper breathing is important. Exhale during the exertion stage of each repetition and inhale during the return stroke. Never hold your breath.

Rest for a short period of time after each set. The ideal resting periods are:

- Rest for three minutes after each set for a muscle building workout.
- Rest for one minute after each set for a toning workout.
- Rest for 30 seconds after each set for a weight loss workout.

Plan to spend the first couple of weeks familiarizing yourself with the equipment and learning the proper form for each exercise.

COOLING DOWN

End each workout with 5 to 10 minutes of stretching. Include stretches for both your arms and legs. Move

slowly as you stretch and do not bounce. Ease into each stretch gradually and go only as far as you can without strain. Stretching at the end of each workout is an effective way to increase flexibility.

STAYING MOTIVATED

For motivation, keep a record of each workout. List the date, the exercises performed, the resistance used, and the numbers of sets and repetitions completed. Record your weight and key body measurements at the end of every month. Remember, the key to achieving the greatest results is to make exercise a regular and enjoyable part of your everyday life.

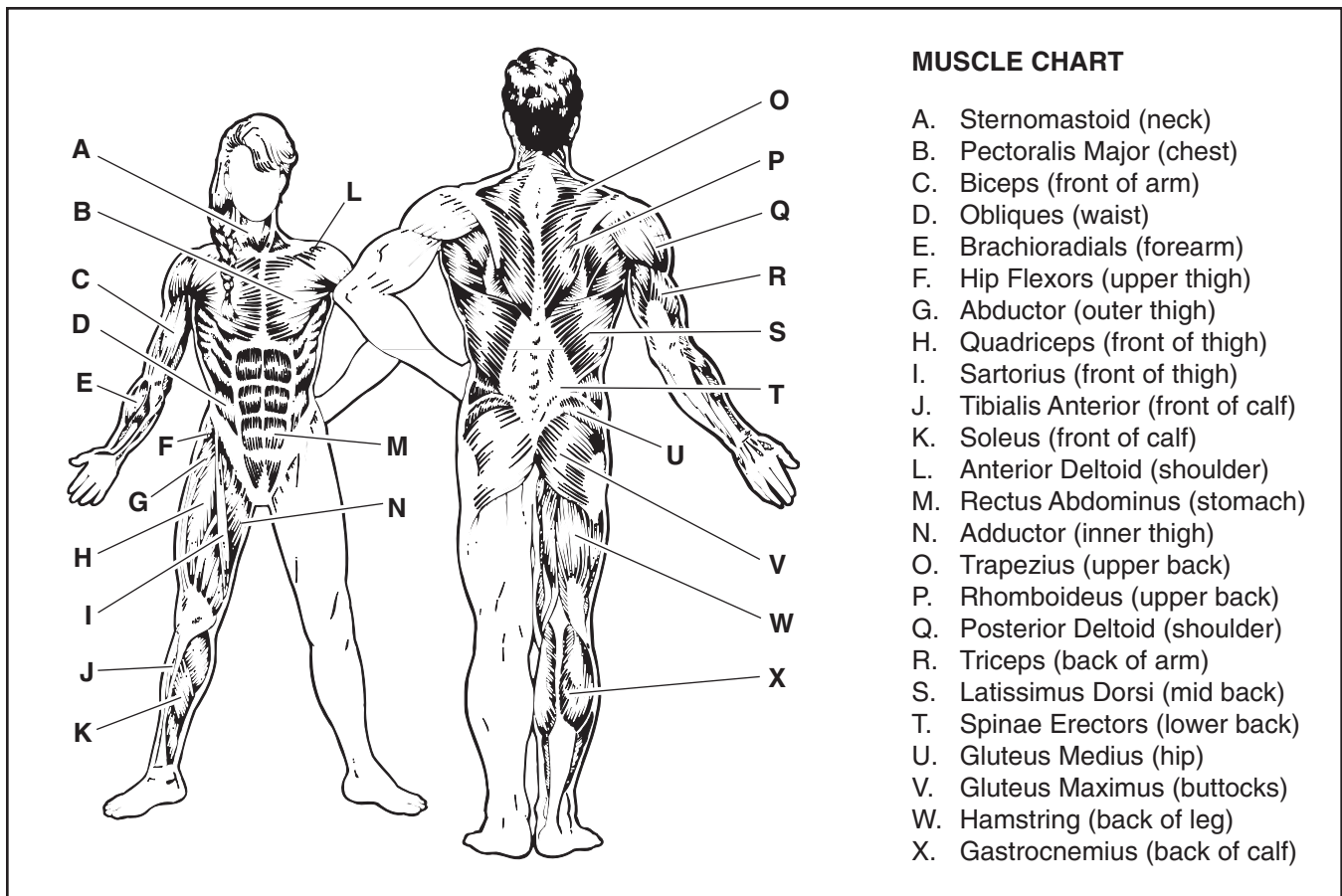

MUSCLE CHART

- A. Sternomastoid (neck)
- B. Pectoralis Major (chest)
- C. Biceps (front of arm)
- D. Obliques (waist)
- E. Brachioradials (forearm)
- F. Hip Flexors (upper thigh)
- G. Abductor (outer thigh)
- H. Quadriceps (front of thigh)
- I. Sartorius (front of thigh)
- J. Tibialis Anterior (front of calf)
- K. Soleus (front of calf)
- L. Anterior Deltoid (shoulder)
- M. Rectus Abdominus (stomach)
- N. Adductor (inner thigh)
- O. Trapezius (upper back)
- P. Rhomboideus (upper back)
- Q. Posterior Deltoid (shoulder)
- R. Triceps (back of arm)
- S. Latissimus Dorsi (mid back)
- T. Spinae Erectors (lower back)
- U. Gluteus Medius (hip)
- V. Gluteus Maximus (buttocks)
- W. Hamstring (back of leg)
- X. Gastrocnemius (back of calf)

NOTES

PART LIST—Model No. WESY3906.0

R0606C

Key No.	Qty.	Description	Key No.	Qty.	Description	Key No.	Qty.	Description
1	1	Right Base	40	3	Upright Bushing	77	1	Lock
2	1	Left Base	41	1	Upright Cover	78	1	Lock Pin
3	1	Right Top Frame	42	8	Handgrip	79	4	2" x 2 1/2" Inner Cap
4	1	Left Top Frame	43	22	Pulley	80	1	Ankle Strap
5	1	Center Base	44	1	"V"-pulley	81	4	Weight Clip
6	1	Center Top Frame	45	9	Guard	82	1	Chain
7	1	Right Upright	46	16	Half Guard	83	1	Long Cable Trap
8	1	Left Upright	47	1	Leg Lever Lock	84	65	M10 Nylon Locknut
9	1	Center Upright	48	10	Cable Trap	85	2	M10 x 100mm Bolt
10	1	Curl Post Upright	49	2	Pulley Plate	86	1	2 1/4" Bolt Set
11	1	Right Seat Upright	50	1	Small Pulley Plate	87	11	M10 x 65mm Bolt
12	1	Leg Press	51	2	2" Square Inner Cap	88	6	M10 x 80mm Carriage Bolt
13	1	Press Frame	52	1	2" x 1 1/2" Inner Cap			
14	1	Left Seat Upright	53	2	2 1/2" x 1 1/2" Inner Cap	89	2	M10 x 35mm Screw
15	1	Leg Lever				90	3	M6 Washer
16	1	Curl Post	54	4	1" x 2" Inner Cap	91	2	Butterfly Foam
17	1	Right Seat Frame	55	12	2" Round Inner Cap	92	2	M8 x 25mm Shoulder Bolt
18	1	Left Seat Frame	56	4	1 1/2" Round Inner Cap			
19	1	Backrest Frame				93	1	Weight Pin
20	1	Military Press Frame	57	23	M10 x 70mm Bolt	94	1	M10 x 150mm Bolt
21	1	Military Press Arm	58	4	3/4" Round Inner Cap	95	8	M10 x 45mm Bolt
22	1	Left Butterfly Arm	59	12	1 1/8" Round Inner Cap	96	1	M10 x 75mm Bolt
23	1	Right Butterfly Arm				97	3	M10 x 120mm Bolt
24	1	Butterfly Frame	60	8	Small Round Bushing	98	2	M6 x 80mm Screw
25	1	Left Press Arm	61	4	Large Round Bushing	99	14	M6 x 16mm Screw
26	1	Right Press Arm	62	4	Leg Lever Bumper	100	18	M4 x 16mm Self-tapping Screw
27	2	Press Arm Handle	63	1	2" Bushing			
28	1	1 3/4" Square Inner Cap	64	1	1 3/4" Bushing	101	1	M8 Nylon Locknut
			65	2	2 3/4" Bushing	102	9	M10 x 90mm Bolt
29	1	Leg Press Plate	66	2	Weight Bumper	103	1	M6 Nylon Locknut
30	2	Weight Guide	67	1	Weight Cap	104	2	M10 x 40mm Bolt
31	1	Top Cover	68	12	1/2" Bushing	105	6	M10 x 50mm Bolt
32	1	Shroud	69	4	Adjustment Knob	106	1	M10 x 130mm Bolt
33	1	Bottom Cover	70	1	Low Cable	107	1	M10 x 95mm Bolt
34	12	12.5-lb. Weight	71	2	3" Bushing	108	44	M10 Washer
35	2	Backrest	72	1	Press Cable	#	1	User's Manual
36	1	Small Seat	73	1	Butterfly Cable	#	1	Exercise Guide
37	1	Large Seat	74	1	Lat Bar	#	2	Hex Key
38	1	Curl Pad	75	1	Weight Tube	#	2	Grease Pack
39	4	Foam Pad	76	1	Weight Tube Cap			

Note: “#” indicates a non-illustrated part. Specifications are subject to change without notice. See the back cover of the user’s manual for information about ordering replacement parts.

EXPLODED DRAWING—Model No. WESY3906.0

R0606C

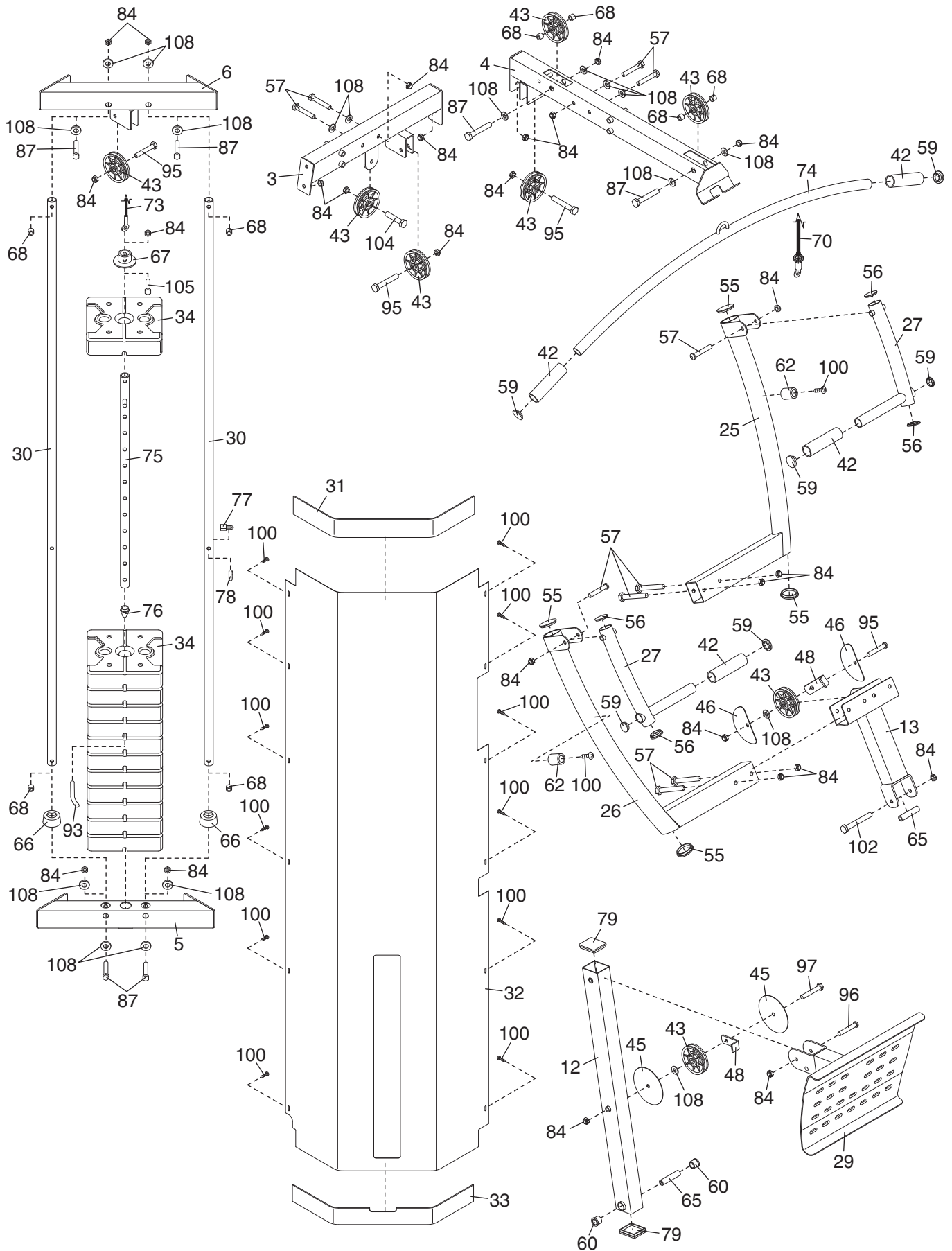

EXPLODED DRAWING—Model No. WESY3906.0

R0606C

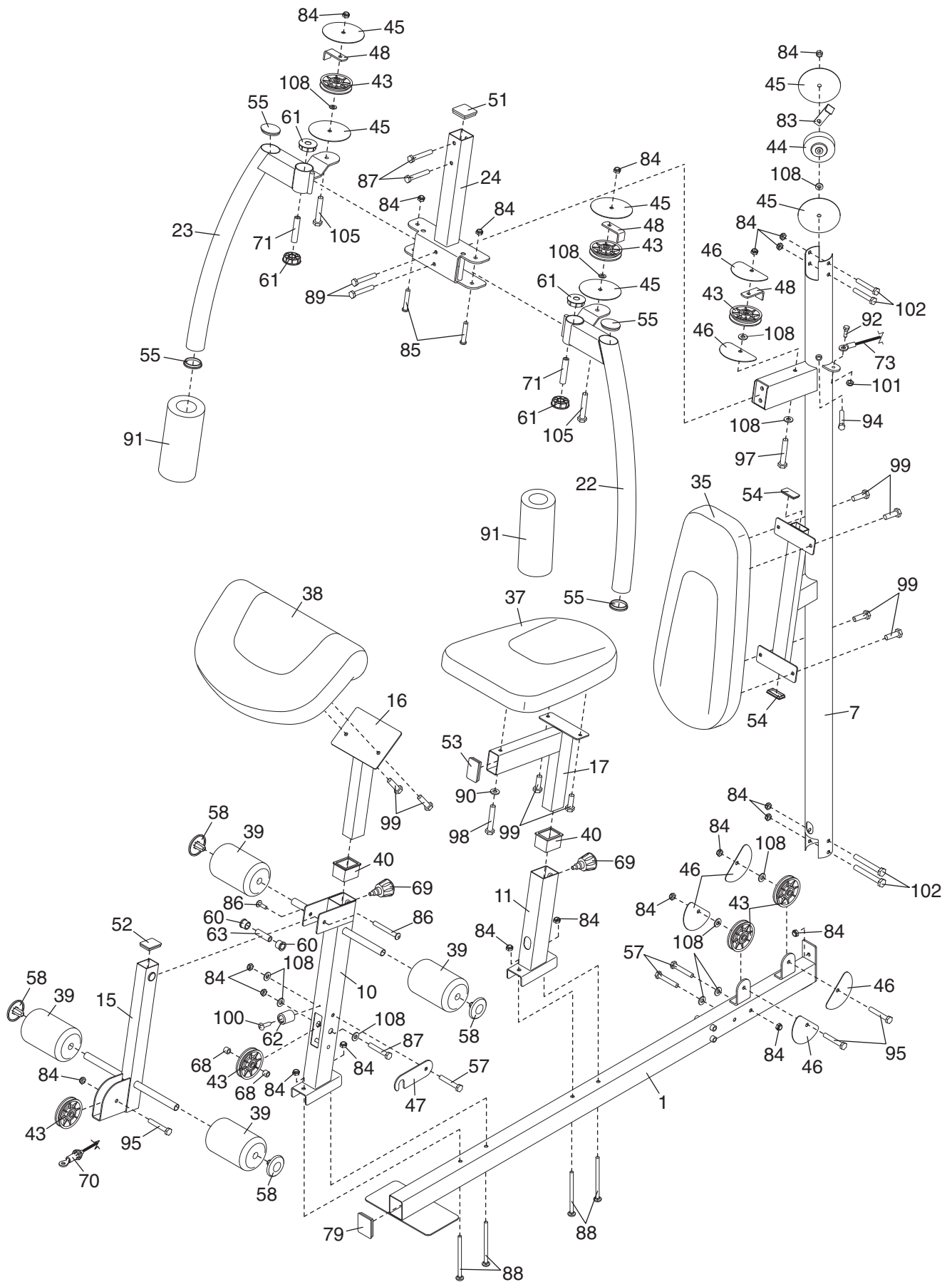

ORDERING REPLACEMENT PARTS

To order replacement parts, see the front cover of this manual. To help us assist you, please be prepared to give the following information:

1. the MODEL NUMBER of the product (WESY3906.0)
2. the NAME of the product (WEIDER CLUB 4870 weight system)
3. the SERIAL NUMBER of the product (see the front cover of this manual)
4. the KEY NUMBER and DESCRIPTION of the part(s) (see the PART LIST and EXPLODED DRAWING on pages 36–39 of this manual)

LIMITED WARRANTY

ICON Health & Fitness, Inc. (ICON), warrants this product to be free from defects in workmanship and material, under normal use and service conditions, for a period of ninety (90) days from the date of purchase. This warranty extends only to the original purchaser. ICON's obligation under this warranty is limited to replacing or repairing, at ICON's option, the product through one of its authorized service centers. All repairs for which warranty claims are made must be pre-authorized by ICON. If the product is shipped to a service center, freight charges to and from the service center will be the customer's responsibility. For in-home service, the customer will be responsible for a minimal trip charge. This warranty does not extend to any product or damage to a product caused by or attributable to freight damage, abuse, misuse, improper or abnormal usage or repairs not provided by an ICON authorized service center; products used for commercial or rental purposes; or products used as store display models. No other warranty beyond that specifically set forth above is authorized by ICON.

ICON is not responsible or liable for indirect, special or consequential damages arising out of or in connection with the use or performance of the product or damages with respect to any economic loss, loss of property, loss of revenues or profits, loss of enjoyment or use, costs of removal or installation or other consequential damages of whatsoever nature. Some states do not allow the exclusion or limitation of incidental or consequential damages. Accordingly, the above limitation may not apply to you.

The warranty extended hereunder is in lieu of any and all other warranties and any implied warranties of merchantability or fitness for a particular purpose is limited in its scope and duration to the terms set forth herein. Some states do not allow limitations on how long an implied warranty lasts. Accordingly, the above limitation may not apply to you.

This warranty gives you specific legal rights. You may also have other rights which vary from state to state.

ICON HEALTH & FITNESS, INC., 1500 S. 1000 W., LOGAN, UT 84321-9813