

WEIDER® CLUB

SideKick™

Model No. WEBE2496.1

Serial No. _____

Write the serial number in the space above for future reference.

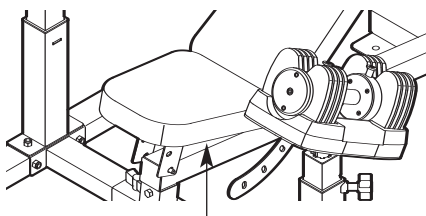

Serial Number Decal (Under Seat)

USER'S MANUAL

QUESTIONS?

As a manufacturer, we are committed to providing complete customer satisfaction. If you have questions, or if parts are missing or damaged, PLEASE DO NOT CONTACT THE STORE. For assistance, contact our Customer Service Department.

CALL TOLL-FREE:

1-877-992-5999

Mon.–Fri., 6 a.m.–6 p.m. MST

ON THE WEB:

www.weiderservice.com

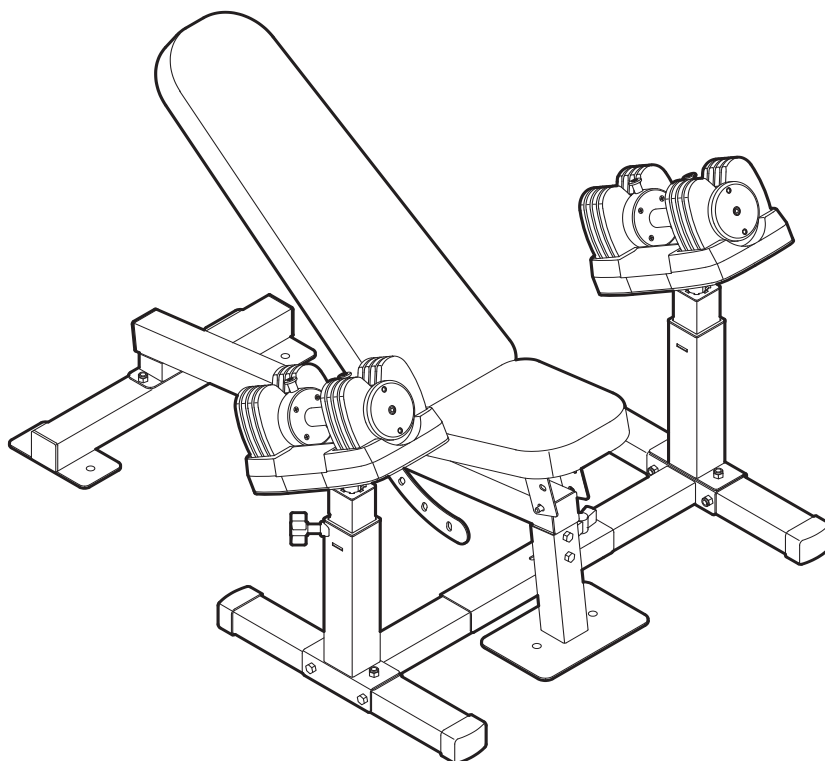

⚠ CAUTION

Read all precautions and instructions in this manual before using this equipment. Save this manual for future reference.



Visit our website at

www.weiderfitness.com

new products, prizes,
fitness tips, and much more!

TABLE OF CONTENTS

WARNING DECAL PLACEMENT2
IMPORTANT PRECAUTIONS	3
BEFORE YOU BEGIN	4
PART IDENTIFICATION CHART	5
ASSEMBLY	6
ADJUSTMENT	10
EXERCISE GUIDELINES	12
PART LIST	14
EXPLODED DRAWING	15
ORDERING REPLACEMENT PARTS	Back Cover
LIMITED WARRANTY	Back Cover

WARNING DECAL PLACEMENT

The decals shown here have been applied to the weight bench. **If a decal is missing or illegible, call the telephone number on the front cover of this manual and request a free replacement decal. Apply the decal in the location shown.** Note: The decals may not be shown at actual size.

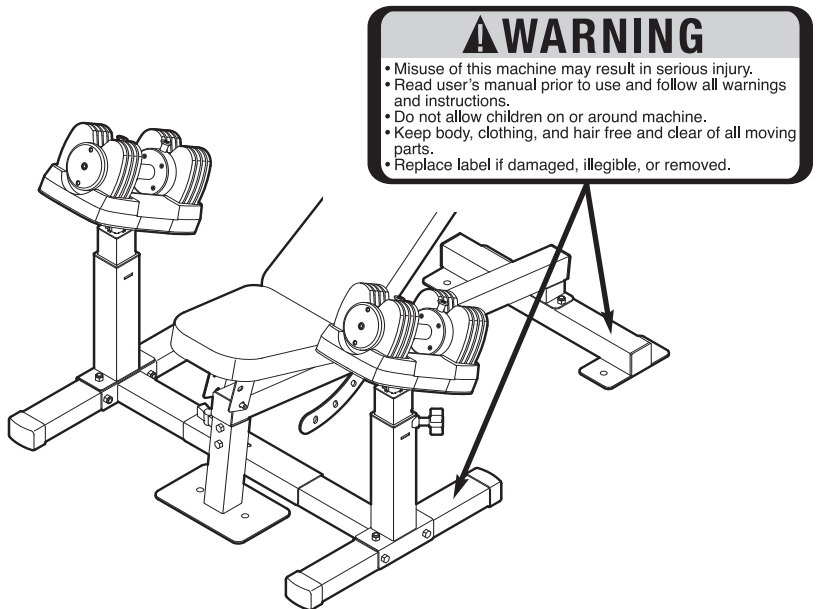

IMPORTANT PRECAUTIONS

⚠ WARNING: To reduce the risk of serious injury, read all important precautions and instructions in this manual and all warnings on the weight bench before using the weight bench. ICON assumes no responsibility for personal injury or property damage sustained by or through the use of the weight bench.

1. Before beginning this or any exercise program, consult your physician. This is especially important for persons over the age of 35 or persons with pre-existing health problems. Read all instructions before using.
2. Read all instructions in this manual and all warnings on the weight bench before using the weight bench. Use the weight bench and the weight stand only as described in this manual.
3. It is the responsibility of the owner to ensure that all users of the weight bench and the weight stand are adequately informed of all precautions.
4. The weight bench and the weight stand are intended for home use only. Do not use the weight bench or the weight stand in any commercial, rental, or institutional setting.
5. Keep the weight bench and the weight stand indoors, away from moisture and dust. Place the weight bench and the weight stand on a level surface, with a mat beneath it to protect the floor or carpet.
6. Make sure that there is enough clearance around the weight bench to mount, dismount, and use the weight bench.
7. Inspect and properly tighten all parts regularly. Replace any worn parts immediately.
8. Keep hands and feet away from moving parts. Do not place your fingers between the dumbbells and the weight stand.
9. Keep children under age 12 and pets away from the weight bench and the weight stand at all times.
10. Always wear athletic shoes for foot protection while exercising.
11. The weight bench is designed to support a maximum user weight of 300 lbs. (136 kg) and a maximum total weight of 510 lbs. (231 kg) Do not use the weight bench with more than 210 lbs. (95 kg) of weight.
12. Place only the included dumbbells on the weight stand.
13. If you feel pain or dizziness while exercising, stop immediately and begin cooling down.

BEFORE YOU BEGIN

Thank you for selecting the versatile WEIDER® CLUB SIDEKICK™ weight bench. The weight bench offers a selection of exercise stations designed to develop the major muscles of the upper body. Whether your goal is to tone your body, build dramatic muscle size and strength, or improve your cardiovascular system, the weight bench will help you to achieve the specific results you want.

For your benefit, read this manual carefully before using the weight bench. If you have questions after reading this manual, please see the front cover of this

manual. To help us assist you, please note the product model number and serial number before calling. The model number and the location of the serial number decal are shown on the front cover of this manual.

To avoid a registration fee for any service needed under warranty, you must register the weight bench at www.weiderservice.com/registration.

Before reading further, please review the drawing below and familiarize yourself with the parts that are labeled.

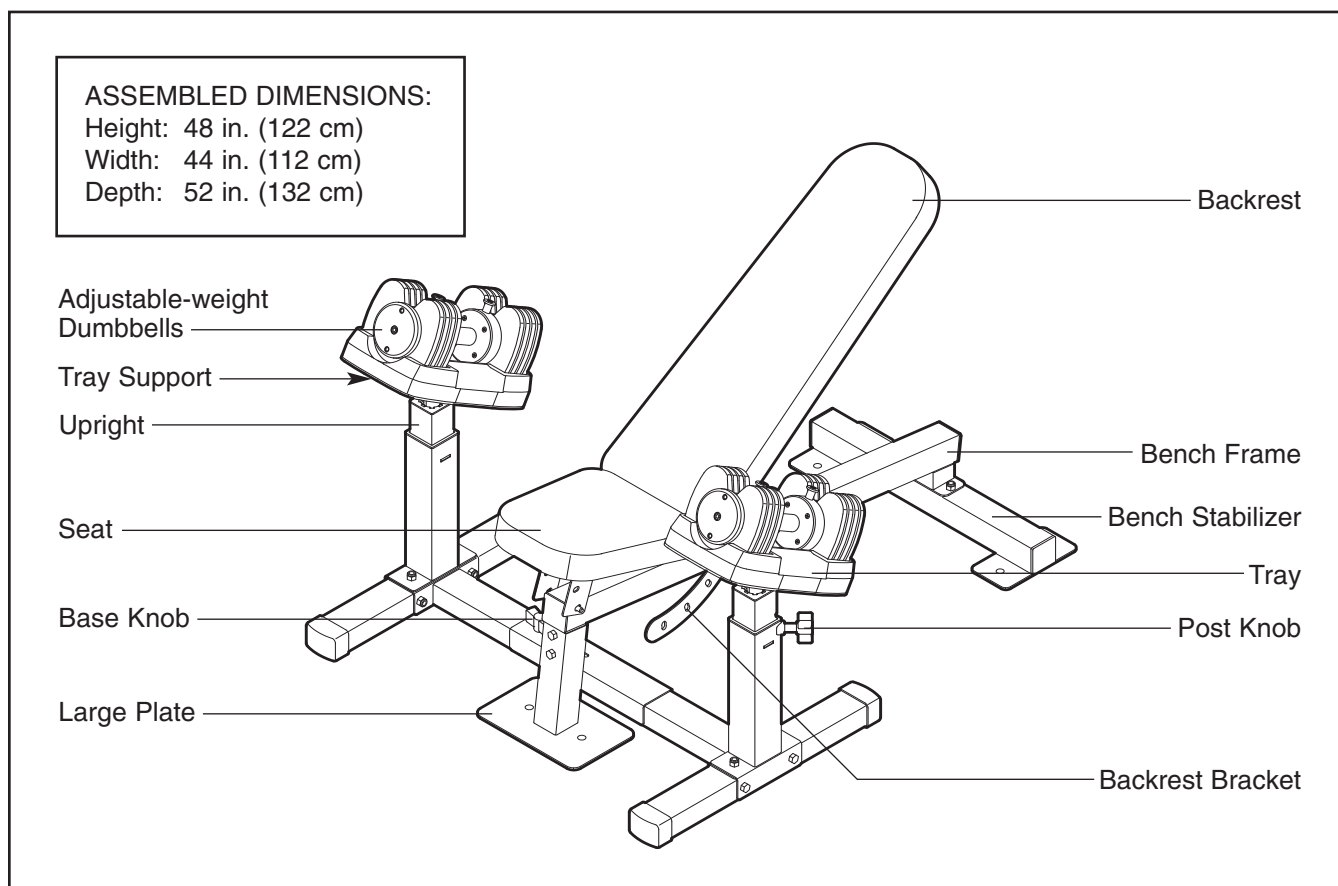

PART IDENTIFICATION CHART

See the drawings below to identify small parts used in assembly. The number in parentheses by each drawing is the key number of the part, from the PART LIST near the end of this manual. **Note: Some small parts may have been pre-assembled. If a part is not in the parts bag, check to see if it has been preassembled.**

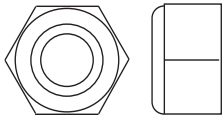

M10 Nylon Locknut (34)

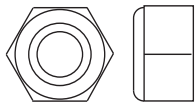

M8 Nylon Locknut (43)

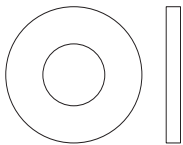

M8 Washer (41)

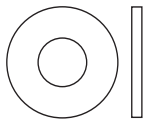

M6 Washer (44)

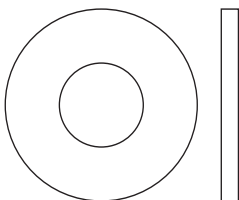

M10 Washer (45)



M4 x 15mm Screw (46)

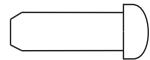

M5 x 15mm Screw (33)

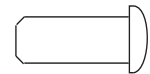

M6 x 15mm Screw (48)



M8 x 15mm Screw (36)



M6 x 35mm Screw (49)

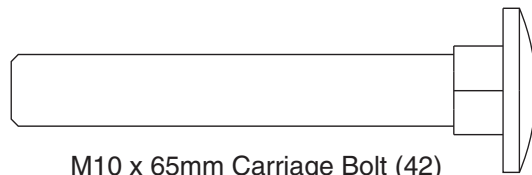

M10 x 65mm Carriage Bolt (42)

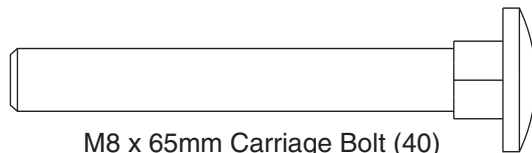

M8 x 65mm Carriage Bolt (40)

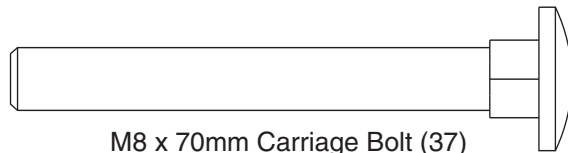

M8 x 70mm Carriage Bolt (37)

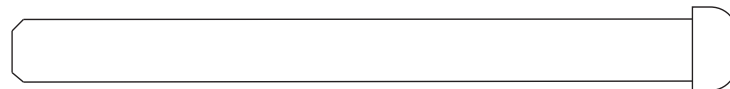

M8 x 90mm Bolt (38)

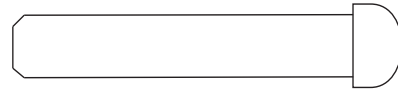

M8 x 45mm Bolts (39)



M8 x 40mm Bolt (50)

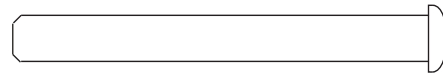

M6 x 55mm Screw (35)

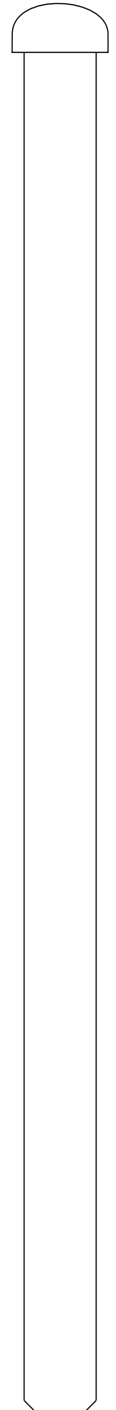

M10 x 180mm Bolt (32)

ASSEMBLY

Make Assembly Easier

Everything in this manual is designed to ensure that the weight bench can be assembled successfully by almost anyone. However, the weight bench has many parts and the assembly process will take time. By setting aside plenty of time, assembly will go smoothly.

Before beginning assembly, carefully read the following information and instructions:

- To hire an authorized service technician to assemble the weight bench, call 1-800-445-2480.
- Assembly requires two persons.
- Because of its size, the weight bench should be assembled in the location where it will be used. Make sure that there is enough clearance to walk around the weight bench as you assemble it.
- Place all parts in a cleared area and remove the

packing materials. Do not dispose of the packing materials until assembly is completed.

- Tighten all parts as you assemble them, unless instructed to do otherwise.
- As you assemble the weight bench, make sure all parts are oriented as shown in the drawings.
- For help identifying small parts, use the PART IDENTIFICATION CHART on page 5.
- Assembly requires the included hex key(s)  and the following tools (not included):

two adjustable wrenches 

one rubber mallet 

one standard screwdriver 

one Phillips screwdriver 

Assembly may be more convenient if you have a socket set, a set of open-end or closed-end wrenches, or a set of ratchet wrenches.

1. **Before beginning assembly, make sure that you understand the information in the box above. For help identifying small parts, see page 5.**

Insert two M8 x 70mm Carriage Bolts (37) up through the Bench Stabilizer (3). Attach a Small Plate (12) to the Bench Stabilizer with two M4 x 15mm Screws (46). Attach the other Small Plate (12) to the Bench Stabilizer in the same way.

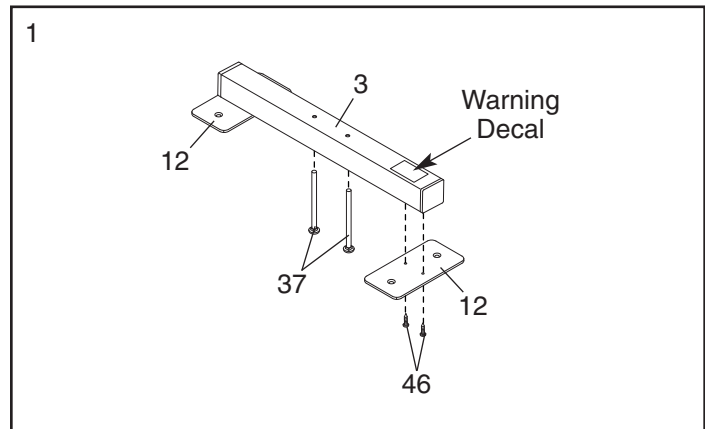

2. Attach the Bench Frame (4) to the Bench Stabilizer (3) with the M8 x 70mm Carriage Bolts (37) and two M8 Nylon Locknuts (43). **Do not tighten the Nylon Locknuts yet.**

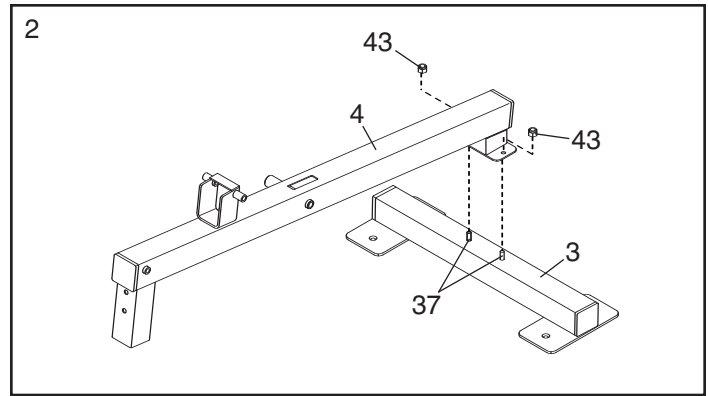

3. Attach the Front Leg (24) to the Bench Frame (4) with four M8 x 15mm Screws (36).

See step 2 and tighten the M8 Nylon Locknuts (43).

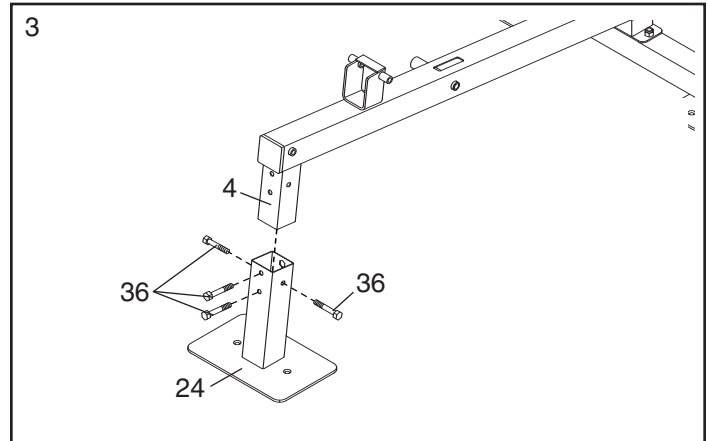

4. Attach the Backrest Bracket (14) to the two Backrest Frames (15) with four M8 x 40mm Bolts (50), four M8 Washers (41), and four M8 Nylon Locknuts (43). **Do not tighten the Nylon Locknuts yet.**

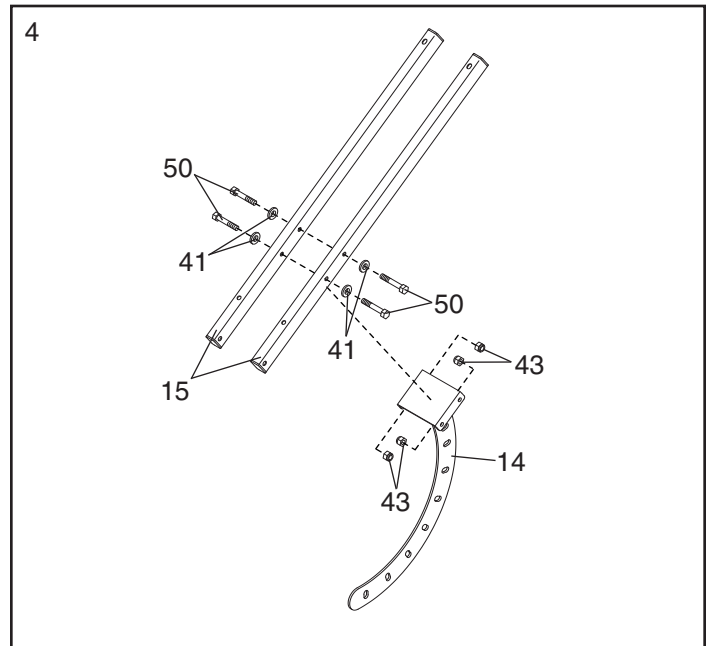

- Attach the Backrest (16) to the Backrest Frames (15) with four M6 x 55mm Screws (35) and four M6 Washers (44). **Do not tighten the Screws yet.**

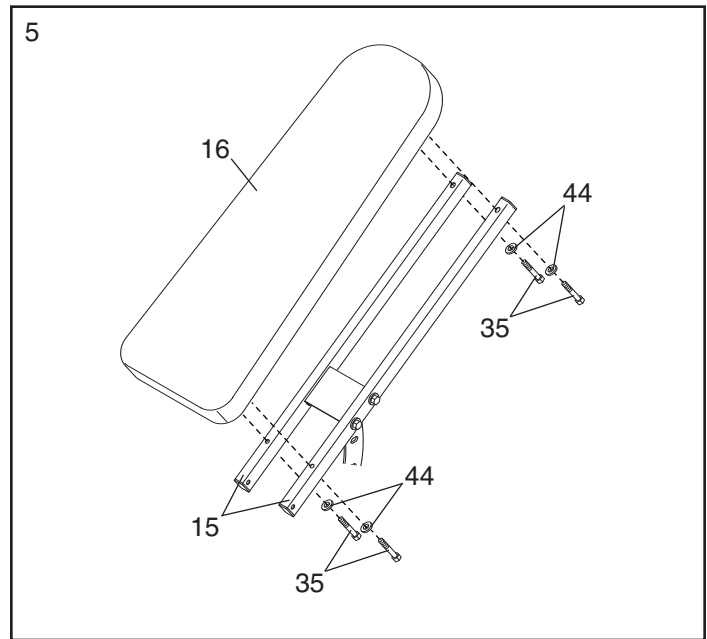

- Attach the Seat (17) and the Seat Carriage (11) to the Seat Frame (5) with two M6 x 15mm Screws (48), two M6 x 35mm Screws (49), and two M6 Washers (44).

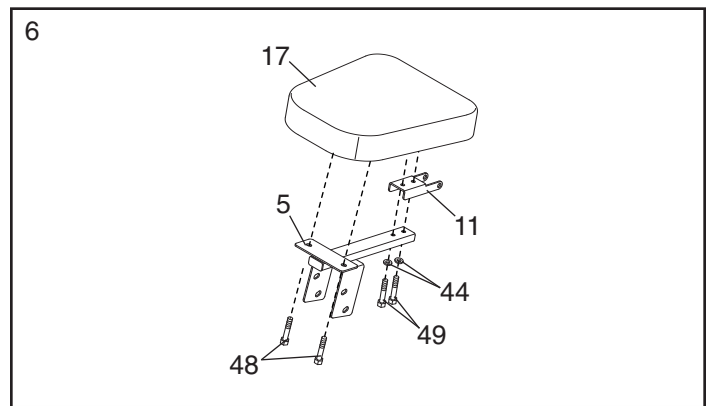

- Insert the Backrest Bracket (14) into the Bench Frame (4). Apply a portion of the included grease to an M10 x 180mm Bolt (32). Attach the Backrest Frames (15) and the Seat Carriage (11) to the Bench Frame with the Bolt, two M10 Washers (45), and an M10 Nylon Locknut (34). **Do not overtighten the Nylon Locknut; the Backrest Frames and the Seat Carriage must pivot freely.**

Tighten the Backrest Knob (28) into the Bench Frame (4). **Make sure that the Backrest Knob engages a hole in the Backrest Bracket (14).**

Tighten the M8 Nylon Locknuts (43) used in step 4 and the M6 x 55mm Screws (35) used in step 5.

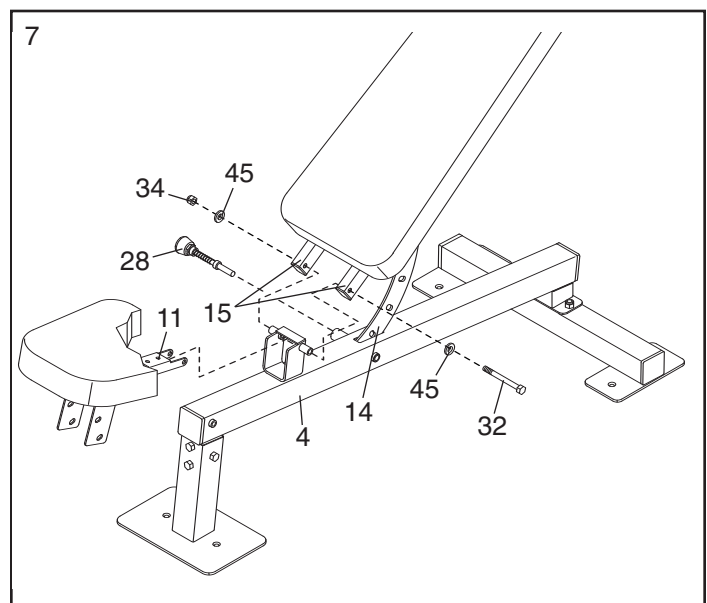

8. Insert the Seat Pin (29) into the Seat Frame (5) and through the Bench Frame (4).

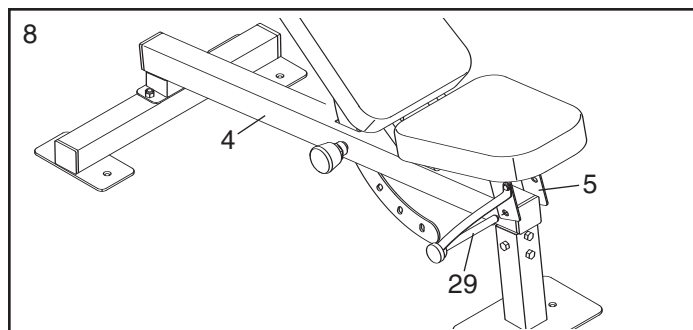

9. Insert two M8 x 65mm Carriage Bolts (40) up through a Rack Stabilizer (1). Attach the Left Post (6) and the Left Base (2) to the Rack Stabilizer with the Carriage Bolts, two M8 x 90mm Bolts (38), and four M8 Nylon Locknuts (43).

Repeat this step with the other Rack Stabilizer (not shown), the Right Base (not shown), and the Right Post (not shown).

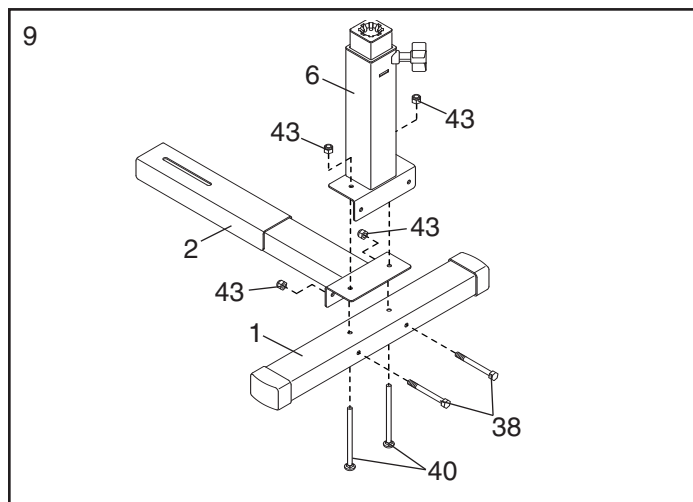

10. Insert the Right Base (51) into the Left Base (2). Insert an M10 x 65mm Carriage Bolt (42) up through the Left and Right Bases. Next, tighten the Base Knob (31) onto the Carriage Bolt.

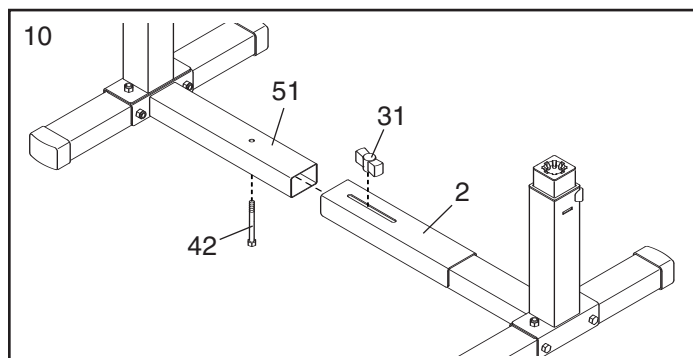

11. Attach a Tray (18) to a Tray Support (10) with two M8 x 45mm Bolts (39) and two M8 Nylon Locknuts (43). Next, insert the Tray Support (10) into the Left Upright (8).

Repeat this step for the other side of the weight rack.

12. **Make sure that all parts are properly tightened before you use the weight bench and the weight rack. The use of all remaining parts will be explained in ADJUSTMENT on page 10.**

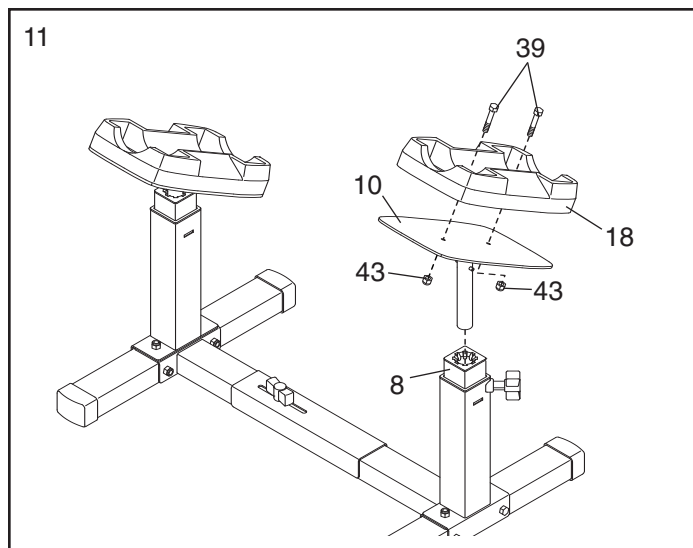

ADJUSTMENT

This section explains how to adjust the weight bench. See the accompanying exercise guide to see the correct form for each exercise. Make sure that all parts are properly tightened each time the weight bench is used. Replace any worn parts immediately. The weight bench can be cleaned with a damp cloth and a mild, non-abrasive detergent. Do not use solvents.

ADJUSTING THE BACKREST AND THE SEAT

To adjust the position of the Backrest (16), pull out on the Backrest Knob (28). Then, adjust the angle of the Backrest and reinsert the Backrest Knob.

To adjust the angle of the Seat (17), pull the Seat Pin (29) out of the Seat Frame (5) and move the Seat up or down. Then, reinsert the Seat Pin through the Seat Frame.

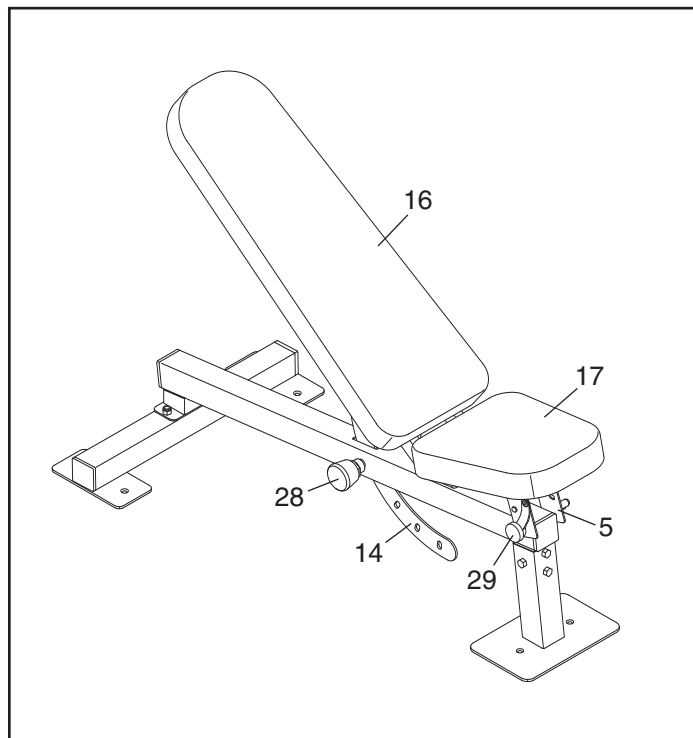

ADJUSTING THE POSITION OF THE TRAYS

To adjust the height of the Trays (18), first remove the Adjustable-Weight Dumbbells (19). Next, loosen the Post Knobs (30) and raise or lower the Left and Right Uprights (8, 9) to the desired height. Then, retighten the Post Knobs. **Make sure that the Post Knobs are inserted into adjustment holes in the Uprights; in addition, make sure that the Uprights are at the same height.**

To adjust the angles of the Trays (18), first remove the Adjustable-Weight Dumbbells (19). Next, lift the Tray Supports (10) and turn them to the desired angles. Then, set the pins on the Tray Supports into the desired notches in the Left and Right Upright Bushings (21, 52).

To adjust the width of the Trays (18), loosen the Base Knob (31) and slide the Left and Right Posts (6, 7) closer together or farther apart. When the Posts are at the desired width, tighten the Base Knob.

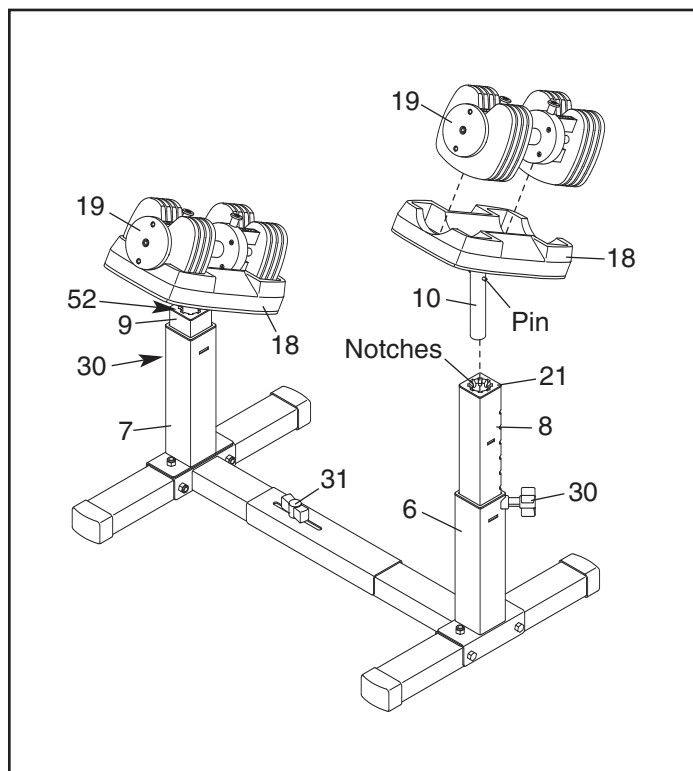

USING THE WEIGHT BENCH WITH THE WEIGHT RACK

The weight bench can be used with the weight rack in the position shown for some exercises. The weight rack can also be set in front of the weight bench for other exercises.

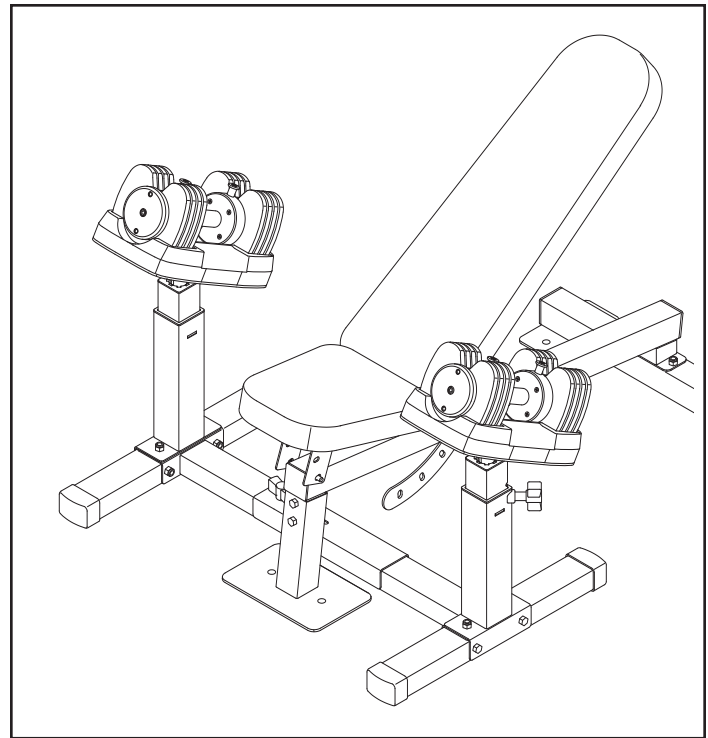

HOW TO USE THE ADJUSTABLE-WEIGHT DUMBBELLS

Each handle can hold two, four, six, or eight weight plates. **Always attach the same number of weight plates to both sides of the handle.**

To select the desired number of weight plates, first set a dumbbell on a Tray (18) as shown. Next, lift one of the selector pins, slide the selector pin to one of the adjustment holes between the weight plates, and then release the selector pin. Rock the selector pin from side to side to make sure that it is fully inserted into one of the adjustment holes. Adjust the other selector pin on the dumbbell in the same way.

To use the dumbbell, lift it straight up off the Tray (18), making sure that the unattached weight plates remain in the Tray.

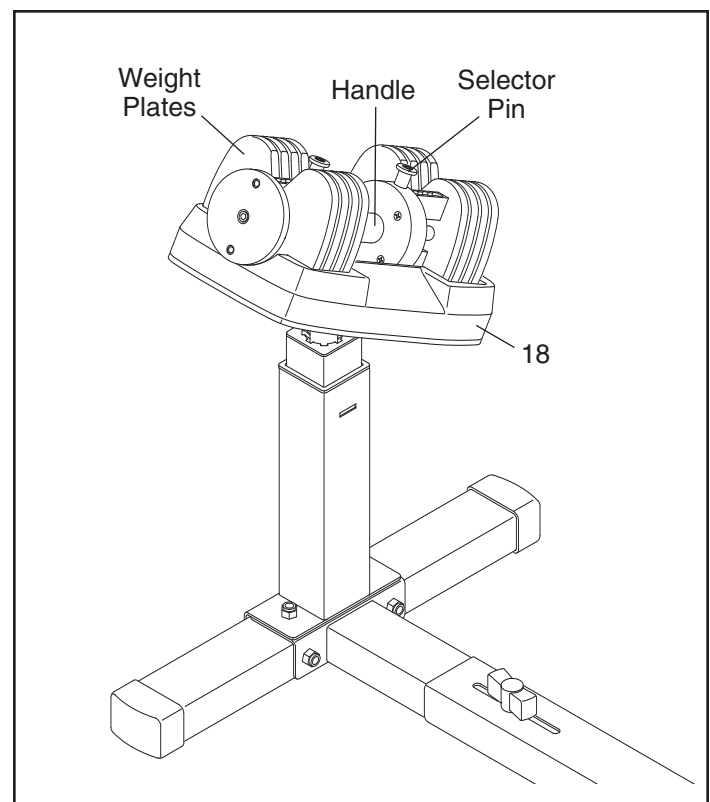

EXERCISE GUIDELINES

THE FOUR BASIC TYPES OF WORKOUTS

Muscle Building

To increase the size and strength of your muscles, push them close to their maximum capacity. Your muscles will adapt and grow as you progressively increase the intensity of your exercise. You can adjust the intensity level of an individual exercise in two ways:

- by changing the amount of weight used
- by changing the number of repetitions or sets performed. (A “repetition” is one complete cycle of an exercise, such as one sit-up. A “set” is a series of repetitions.)

The proper amount of weight for each exercise depends upon the individual user. You must gauge your limits and select the amount of weight that is right for you. Begin with 3 sets of 8 repetitions for each exercise you perform. Rest for 3 minutes after each set. When you can complete 3 sets of 12 repetitions without difficulty, increase the amount of weight.

Toning

You can tone your muscles by pushing them to a moderate percentage of their capacity. Select a moderate amount of weight and increase the number of repetitions in each set. Complete as many sets of 15 to 20 repetitions as possible without discomfort. Rest for 1 minute after each set. Work your muscles by completing more sets rather than by using high amounts of weight.

Weight Loss

To lose weight, use a low amount of weight and increase the number of repetitions in each set. Exercise for 20 to 30 minutes, resting for a maximum of 30 seconds between sets.

Cross Training

Cross training is an efficient way to get a complete and well-balanced fitness program. An example of a balanced program follows:

- Plan strength training workouts on Monday, Wednesday, and Friday.
- Plan 20 to 30 minutes of aerobic exercise, such as running on a treadmill or riding on an exercise cycle or an elliptical exerciser, on Tuesday and Thursday.
- Rest from both strength training and aerobic exercise for at least one full day each week to give your body time to regenerate.

The combination of strength training and aerobic exercise will reshape and strengthen your body, plus develop your heart and lungs.

PERSONALIZING YOUR EXERCISE PROGRAM

Determining the appropriate length of time for each workout, and the numbers of repetitions and sets to complete, is an individual matter. It is important to avoid overdoing it during the first few months of your exercise program. Progress at your own pace and be sensitive to your body’s signals. If you experience pain or dizziness at any time while exercising, stop immediately and begin cooling down. Find out what is wrong before continuing. Remember that adequate rest and a proper diet are important factors in any exercise program.

WARMING UP

Begin each workout with 5 to 10 minutes of stretching and light exercise to warm up. Warming up prepares your body for more strenuous exercise by increasing circulation, raising your body temperature and delivering more oxygen to your muscles.

WORKING OUT

Each workout should include 6 to 10 different exercises. Select exercises for every major muscle group, emphasizing areas that you want to develop most. To give balance and variety to your workouts, vary the exercises from session to session.

Schedule your workouts for the time of day when your energy level is the highest. Each workout should be followed by at least one day of rest. Once you find the schedule that is right for you, stick with it.

EXERCISE FORM

Maintaining proper form is an essential part of an effective exercise program. This requires moving through the full range of motion for each exercise, and moving only the appropriate parts of the body. Exercising in an uncontrolled way will leave you feeling exhausted. On the exercise guide accompanying this manual you will find photographs showing the correct form for several exercises, and a list of the muscles affected. Refer to the muscle chart on the next page to find the names of the muscles.

The repetitions in each set should be performed smoothly and without pausing. The exertion stage of each repetition should last about half as long as the return stage. Proper breathing is important. Exhale during the exertion stage of each repetition and inhale during the return stroke. Never hold your breath.

Rest for a short period of time after each set. The ideal resting periods follow:

- Rest for three minutes after each set for a muscle building workout.
- Rest for one minute after each set for a toning workout.
- Rest for 30 seconds after each set for a weight loss workout.

Plan to spend the first couple of weeks familiarizing yourself with the equipment and learning the proper form for each exercise.

COOLING DOWN

End each workout with 5 to 10 minutes of stretching. Include stretches for both your arms and legs. Move

slowly as you stretch and do not bounce. Ease into each stretch gradually and go only as far as you can without strain. Stretching at the end of each workout is an effective way to increase flexibility.

STAYING MOTIVATED

For motivation, keep a record of each workout. List the date, the exercises performed, the resistance used, and the numbers of sets and repetitions completed. Record your weight and key body measurements at the end of every month. Remember, the key to achieving the greatest results is to make exercise a regular and enjoyable part of your everyday life.

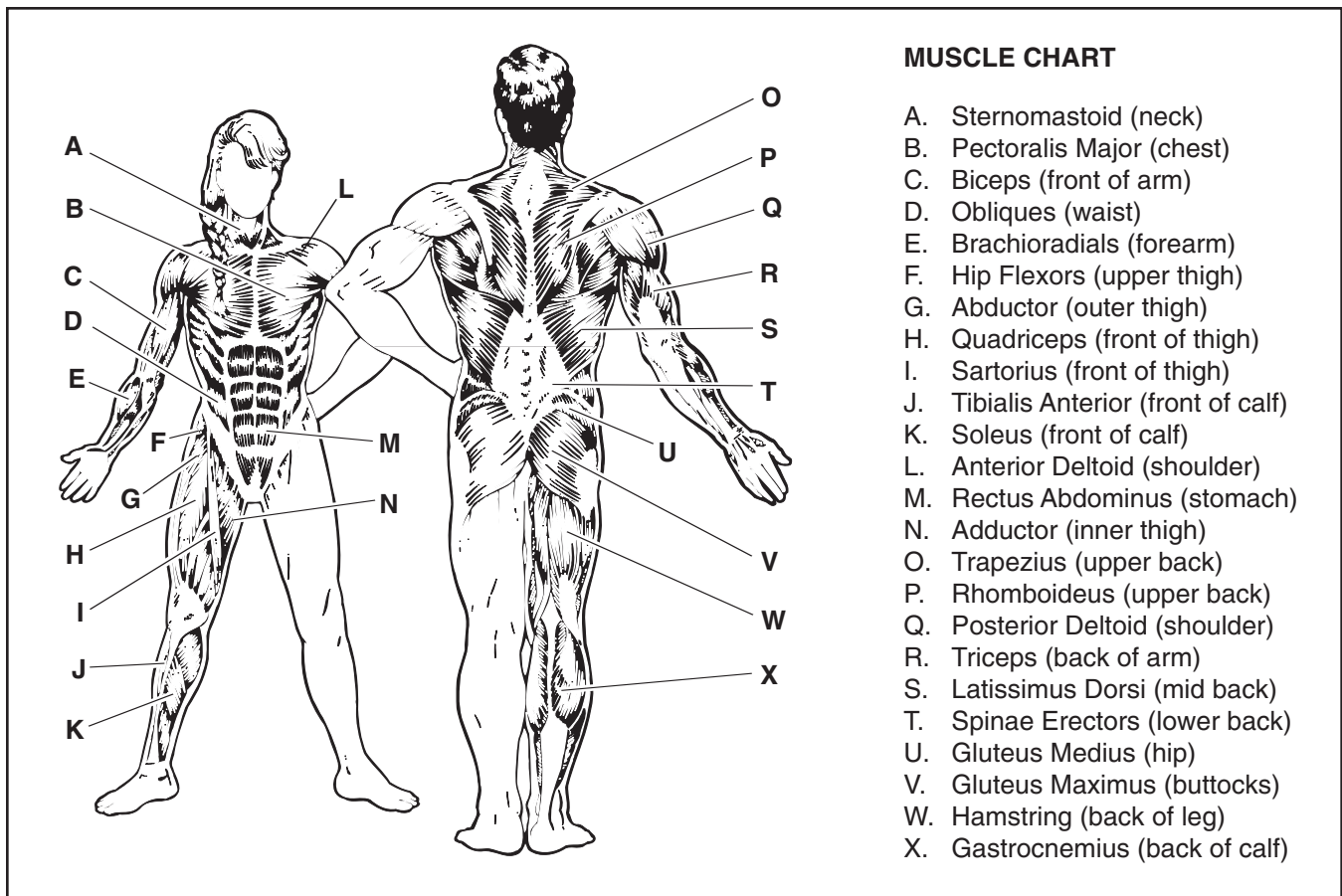

PART LIST—Model No. WEBE2496.1

R0607A

Key No.	Qty.	Description	Key No.	Qty.	Description
1	2	Rack Stabilizer	29	1	Seat Pin
2	1	Left Base	30	2	Post Knob
3	1	Bench Stabilizer	31	1	Base Knob
4	1	Bench Frame	32	1	M10 x 180mm Bolt
5	1	Seat Frame	33	4	M5 x 15mm Screw
6	1	Left Post	34	1	M10 Nylon Locknut
7	1	Right Post	35	4	M6 x 55mm Screw
8	1	Left Upright	36	4	M8 x 15mm Screw
9	1	Right Upright	37	2	M8 x 70mm Carriage Bolt
10	2	Tray Support	38	4	M8 x 90mm Bolt
11	1	Seat Carriage	39	4	M8 x 45mm Bolt
12	2	Small Plate	40	4	M8 x 65mm Carriage Bolt
13	1	Right Post Bushing	41	4	M8 Washer
14	1	Backrest Bracket	42	1	M10 x 65mm Carriage Bolt
15	2	Backrest Frame	43	18	M8 Nylon Locknut
16	1	Backrest	44	6	M6 Washer
17	1	Seat	45	2	M10 Washer
18	2	Tray	46	5	M4 x 15mm Screw
19	2	Adjustable-weight Dumbbell	47	1	40mm x 20mm Endcap
20	16	Weight Plate	48	2	M6 x 15mm Screw
21	2	Left Upright Bushing	49	2	M6 x 35mm Screw
22	1	Left Post Bushing	50	4	M8 x 40mm Bolt
23	2	56mm Square Cap	51	1	Right Base
24	1	Front Leg	52	1	Right Upright Bushing
25	4	50mm x 75mm Endcap	*	—	User's Manual
26	4	60mm Square Cap	*	—	Hex Key
27	4	40mm x 25mm Cap	*	—	Grease Packet
28	1	Backrest Knob	*	—	Exercise Guide

Note: Specifications are subject to change without notice. See the back cover of this manual for information about ordering replacement parts. *These parts are not illustrated.

EXPLODED DRAWING—Model No. WEBE2496.1

R0607A

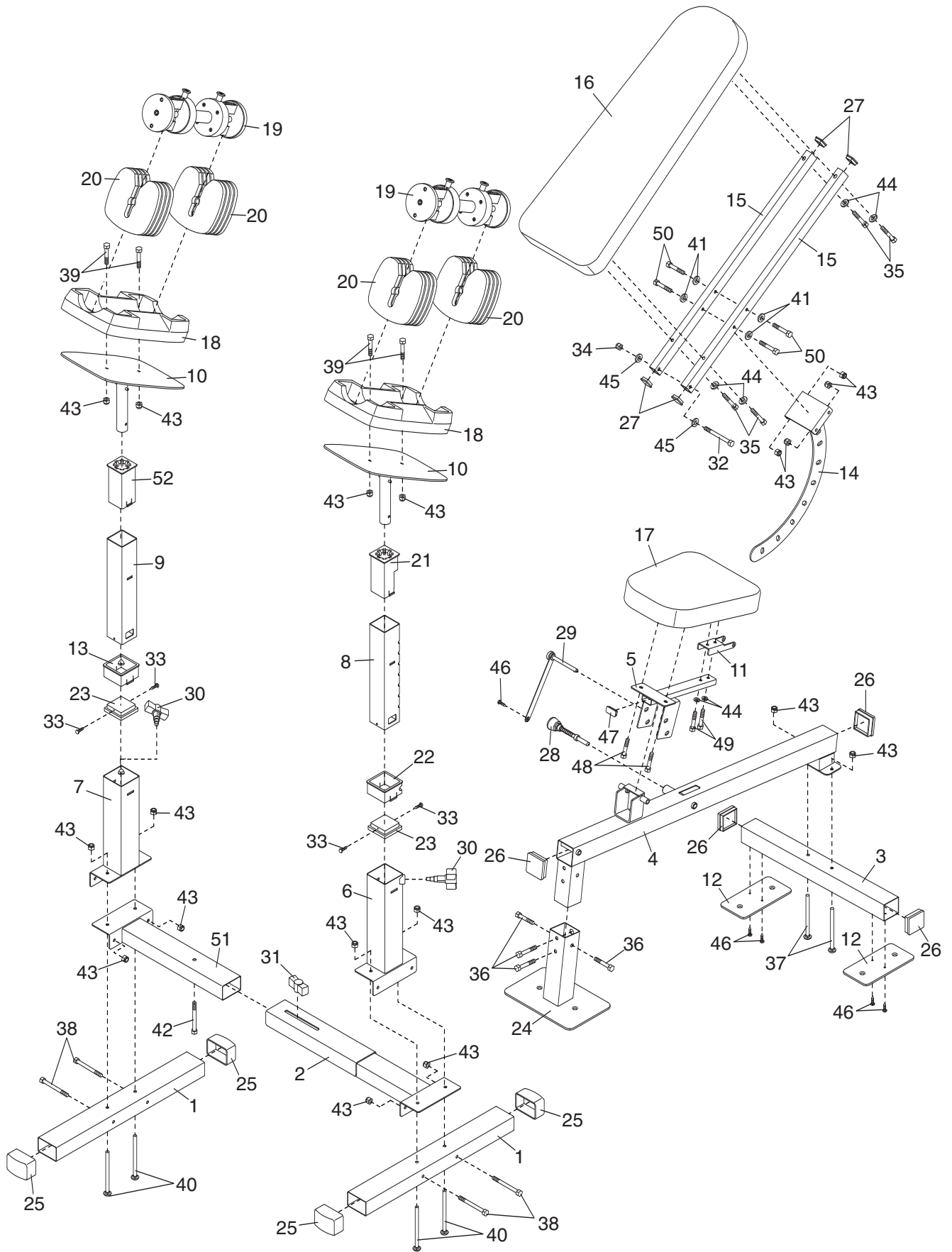

ORDERING REPLACEMENT PARTS

To order replacement parts, please see the front cover of this manual. To help us assist you, be prepared to provide the following information when contacting us:

- the model number and serial number of the product (see the front cover of the manual)
- the name of the product (see the front cover of this manual)
- the key number and description of the part(s) (see the PART LIST and the EXPLODED DRAWING near the end of this manual)

LIMITED WARRANTY

ICON Health & Fitness, Inc. (ICON) warrants this product to be free from defects in workmanship and material, under normal use and service conditions, for a period of ninety (90) days from the date of purchase. This warranty extends only to the original purchaser. ICON's obligation under this warranty is limited to replacing or repairing, at ICON's option, the product through one of its authorized service centers. All repairs for which warranty claims are made must be pre-authorized by ICON. If the product is shipped to a service center, freight charges to and from the service center will be the customer's responsibility. For in-home service, the customer will be responsible for a minimal trip charge. This warranty does not extend to any product or damage to a product caused by or attributable to freight damage, abuse, misuse, improper or abnormal usage or repairs not provided by an ICON authorized service center; products used for commercial or rental purposes; or products used as store display models. No other warranty beyond that specifically set forth above is authorized by ICON.

ICON is not responsible or liable for indirect, special or consequential damages arising out of or in connection with the use or performance of the product or damages with respect to any economic loss, loss of property, loss of revenues or profits, loss of enjoyment or use, costs of removal or installation or other consequential damages of whatsoever nature. Some states do not allow the exclusion or limitation of incidental or consequential damages. Accordingly, the above limitation may not apply to you.

The warranty extended hereunder is in lieu of any and all other warranties and any implied warranties of merchantability or fitness for a particular purpose is limited in its scope and duration to the terms set forth herein. Some states do not allow limitations on how long an implied warranty lasts. Accordingly, the above limitation may not apply to you.

This warranty gives you specific legal rights. You may also have other rights which vary from state to state.

ICON HEALTH & FITNESS, INC., 1500 S. 1000 W., LOGAN, UT 84321-9813