

WEIDER[®] FLEX GYM 2000

Model No. WESY20000

Serial No. _____

Write the serial number in the space above for reference.

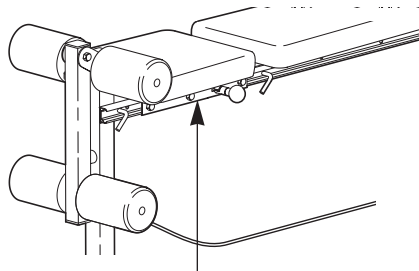

Serial Number Decal (under seat)

USER'S MANUAL

QUESTIONS?

As a manufacturer, we are committed to providing complete customer satisfaction. If you have questions, or if there are missing parts, we will guarantee complete satisfaction through direct assistance from our factory.

TO AVOID DELAYS, PLEASE CALL DIRECT TO OUR TOLL-FREE CUSTOMER HOT LINE. The trained technicians on our customer hot line will provide immediate assistance, free of charge.

CUSTOMER HOT LINE:
1-800-999-3756
Mon.-Fri., 6 a.m.-6 p.m. MST

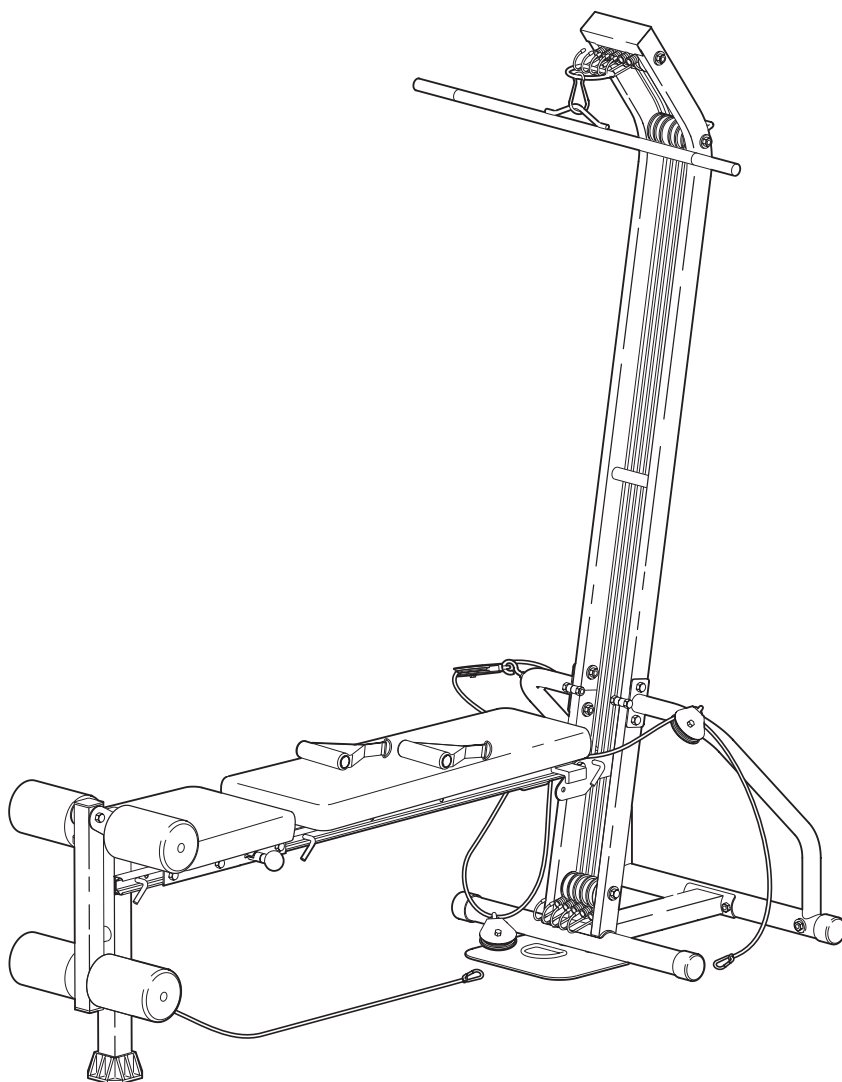

CAUTION

Read all precautions and instructions in this manual before using this equipment. Save this manual for future reference.



Visit our website at

www.weiderfitness.com

new products, prizes,
fitness tips, and much more!

Table of Contents

Warning Decal Placement	2
Important Precautions	3
Before You Begin	4
Part Identification Chart	5
Assembly	6
Adjusting the Weight System	11
Exercise Guidelines	13
Ordering Replacement Parts	Back Cover
Limited Warranty	Back Cover

Note: An Exploded Drawing and a Part List are attached in the center of this manual.

Warning Decal Placement

The decals shown at the right have been placed on the weight system. If a decal is missing or illegible, please call our Customer Service Department toll-free at 1-800-999-3756, Monday through Friday, 6 a.m. until 6 p.m. Mountain Time, to order a free replacement decal. Apply the replacement decal in the location shown.

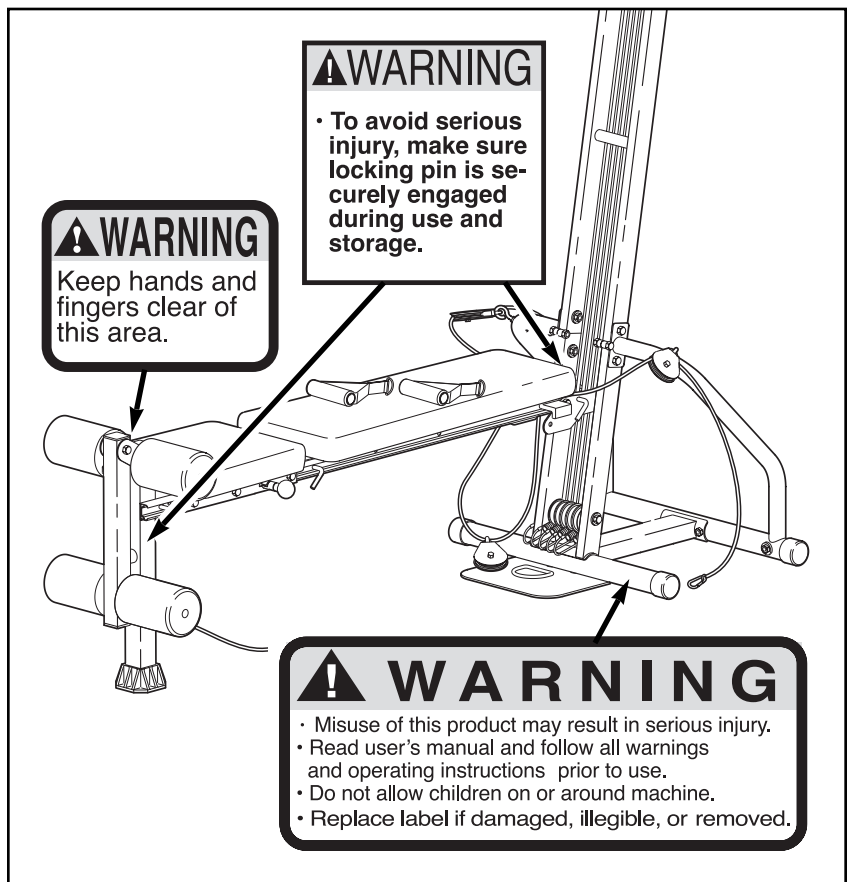

Important Precautions

⚠️ WARNING: To reduce the risk of serious injury, read the following important precautions before using the weight system.

1. Read all instructions in this manual before using the weight system.
2. It is the responsibility of the owner to ensure that all users of the weight system are adequately informed of all precautions.
3. The weight system is intended for home use only. Do not use the weight system in any commercial, rental, or institutional setting.
4. Use the weight system only as described in this manual.
5. Use the weight system only on a level surface. Cover the floor beneath the weight system to protect the floor.
6. Inspect and tighten all parts each time you use the weight system. Replace any worn parts immediately. Replace the resistance cords at least every two years.
7. Keep children under the age of 12 and pets away from the weight system at all times.
8. Keep hands and feet away from moving parts.
9. Always wear athletic shoes for foot protection while exercising.
10. Always remove the lat bar from the resistance cords when the lat bar is not in use.
11. Never release the lat bar while the resistance cords are stretched.
12. Always retract the resistance cords in a controlled manner. Hold the ends firmly when connecting or removing the hook ends.
13. Replace the resistance cords if the rubber protective tips are damaged or missing. Do not use without protective rubber tips on the hooks or if the resistance cords are worn or damaged.
12. If you feel pain or dizziness at any time while exercising, stop immediately and begin cooling down.

⚠️ WARNING: Before beginning this or any exercise program, consult your physician. This is especially important for persons over the age of 35 or persons with pre-existing health problems. Read all instructions before using. ICON assumes no responsibility for personal injury or property damage sustained by or through the use of this product.

Before You Begin

Thank you for selecting the versatile WEIDER® FLEX GYM 2000. The FLEX GYM 2000 is designed to help you develop every major muscle group of the body. Whether your goal is a shapely figure, dramatic increase in muscle size and strength, or a healthier cardiovascular system, the FLEX GYM 2000 will help you achieve the specific results you want.

For your benefit, read this manual carefully before using the FLEX GYM 2000. If you have additional questions, please call our Customer Service

Department toll-free at 1-800-999-3756, Monday through Friday, 6 a.m. until 6 p.m. Mountain Time (excluding holidays). To help us assist you, please note the product model number and serial number before calling. The model number is WESY20000. The serial number can be found on a decal attached to the weight system (see the front cover of this manual).

Before reading further, please look at the drawing below and familiarize yourself with the parts that are labeled.

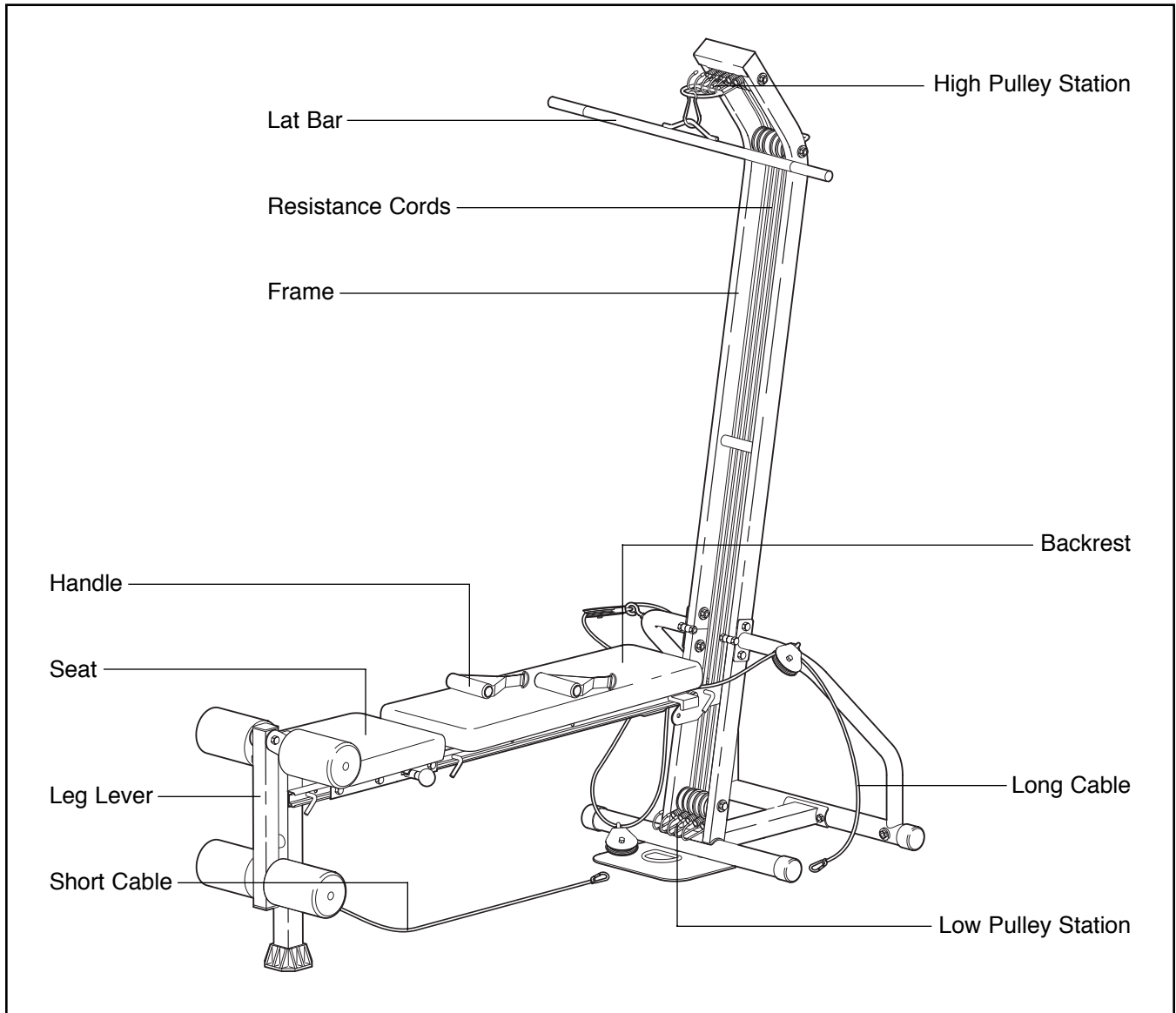

Part Identification Chart—Model No. WESY20000

R0800A

Refer to the drawings below to identify small parts used in assembly. The number in parenthesis below each drawing is the key number of the part, from the Part List in the center of this manual. The number following the key number is the quantity used in assembly. **Note: Some small parts may have been pre-attached. If a part is not in the parts bag, check to see if it has been pre-attached.**

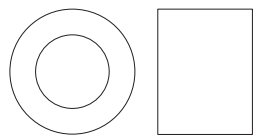

12.5mm Spacer (35)–2

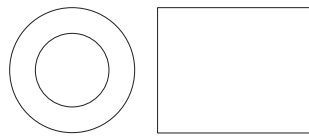

21mm Spacer (41)–2

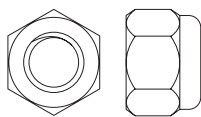

M8 Nylon Locknut (37)–2

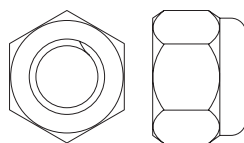

M10 Nylon Locknut (42)–18

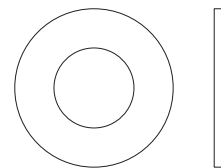

M10 Flat Washer (44)–16

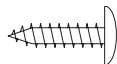

M4 x 16mm Screw (26)–1



M4 x 25mm Screw (57)–2

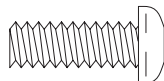

M6 x 16mm Screw (31)–8

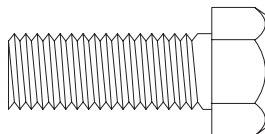

M10 x 27mm Bolt (51)–3

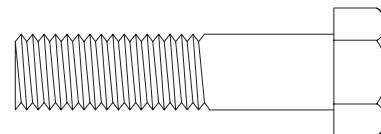

M10 x 42mm Bolt (46)–4

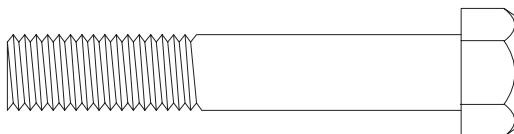

M10 x 60mm Bolt (38)–1

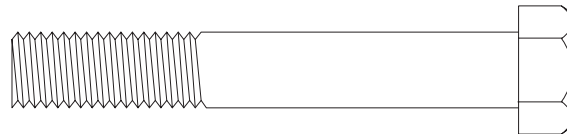

M10 x 67mm Bolt (48)–7

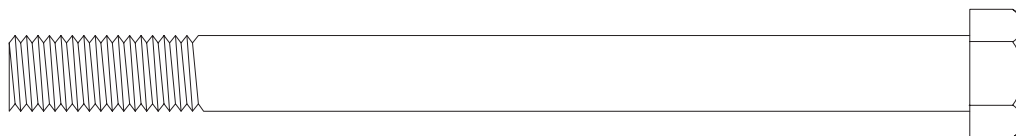

M10 x 127mm Bolt (43)–1



Assembly

Before beginning assembly, carefully read the following information and instructions:

- Place all parts of the weight system in a cleared area and remove the packing materials; do not dispose of the packing materials until assembly is completed.
- Read all assembly steps before you begin.
- For help identifying small parts used in assembly, use the PART IDENTIFICATION CHART on page 5. **Note: Some small parts may have been pre-attached for shipping. If a part is not in the parts bag, check to see if it has been pre-attached.**
- Tighten all parts as you assemble them, unless instructed to do otherwise.

- As you assemble the weight system, make sure that all parts are oriented as shown in the drawings.

THE FOLLOWING TOOLS (NOT INCLUDED) ARE REQUIRED FOR ASSEMBLY:

- **Two adjustable wrenches** 
- **One phillips screwdriver** 
- **One rubber mallet** 
- **Lubricant, such as grease or petroleum jelly, and soapy water are also needed.**

Assembly will be more convenient if you have a socket set, a set of open-end or closed-end wrenches, or a set of ratchet wrenches.

1. Press a 51mm Round Outer Cap (20) onto each end of the Front Stabilizer (6). Make sure the welded bolts are facing up.

With the help of another person, pivot the Upper Frame (1) so that it aligns with the Lower Frame (2) as shown. Secure the Upper and Lower Frames in place by tightening the two M10 x 36mm Button Head Bolts (45) and M10 Nylon Locknuts (42).

Place the Frame (1, 2) on the welded bolts on the Front Stabilizer (6).

2. While another person holds the Upper Frame (2) upright, place the Base (7) on the welded bolts on the Front Stabilizer (6). Attach the Base and the Frame (1, 2) to the Front Stabilizer using two M10 Nylon Locknuts (42). **Do not tighten the Nylon Locknuts yet.**

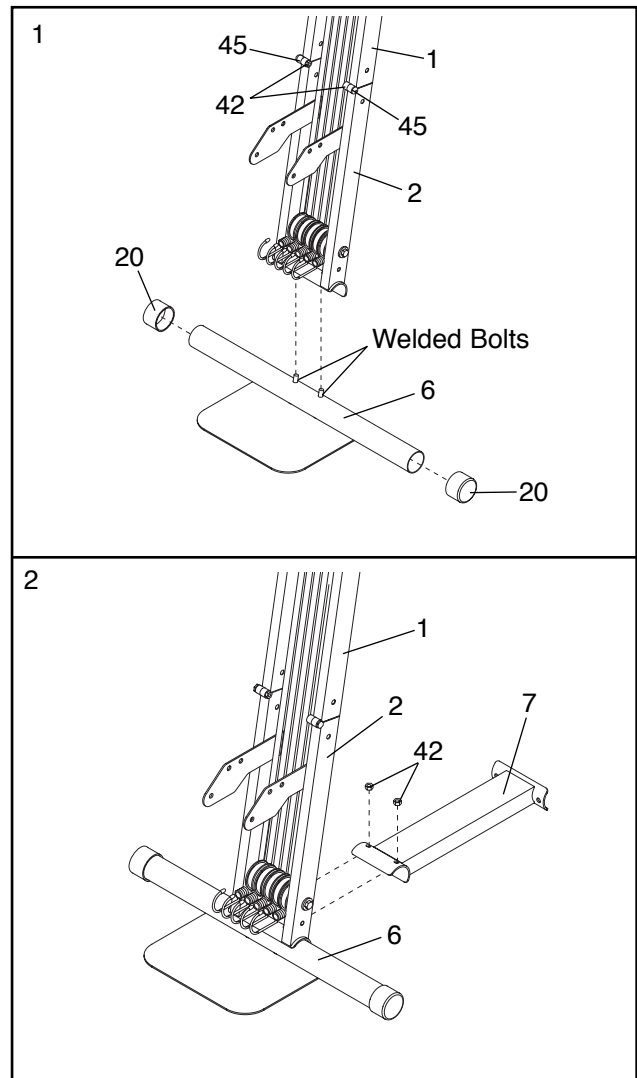

3. Press a 51mm Round Outer Cap (20) onto each end of the Rear Stabilizer (3).

Attach the Rear Stabilizer (3) to the Base (7) using two M10 x 67mm Bolts (48), two M10 Flat Washers (44), and two M10 Nylon Locknuts (42). Make sure the Rear Stabilizer is turned as shown, with the large holes facing up. **Do not tighten Nylon Locknuts yet.**

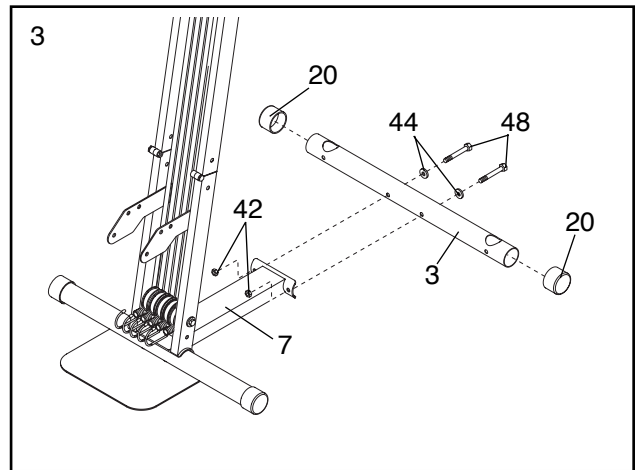

4. Slide the indicated end of the Right Brace (4) into the large hole in the Rear Stabilizer (3). Attach the Right Brace to the Rear Stabilizer using an M10 x 67mm Bolt (48), two M10 Flat Washers (44), and an M10 Nylon Locknut (42). Attach the bracket on the Right Brace to the Frame (1, 2) using two M10 x 42mm Bolts (46), two M10 Flat Washers (44), and two M10 Nylon Locknuts (42).

Attach the Left Brace (5, not shown) to the Rear Stabilizer (3) and the Frame (1, 2) in the same manner.

Tighten all Nylon Locknuts used in steps 1 to 4.

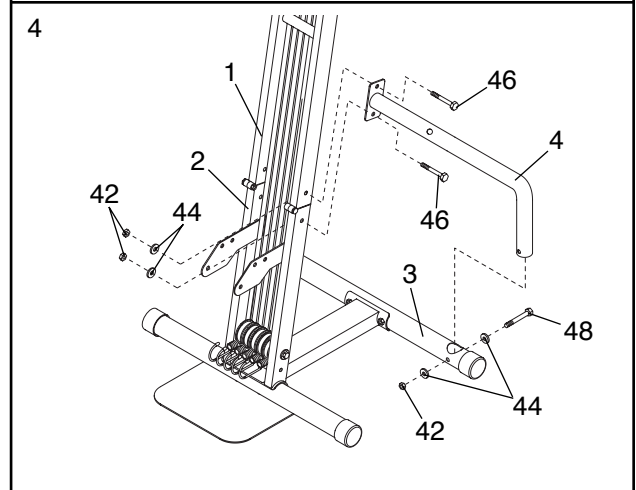

5. Lubricate an M10 x 127mm Bolt (43). Using the Bolt and an M10 Nylon Locknut (42), attach the Rail (8) to the bracket on the Lower Frame (2). Do not over-tighten the Nylon Locknut. The Rail must be able to pivot freely for storage. Slide the Medium Lock Pin (58) through the indicated holes in the Lower Frame and the Rail.

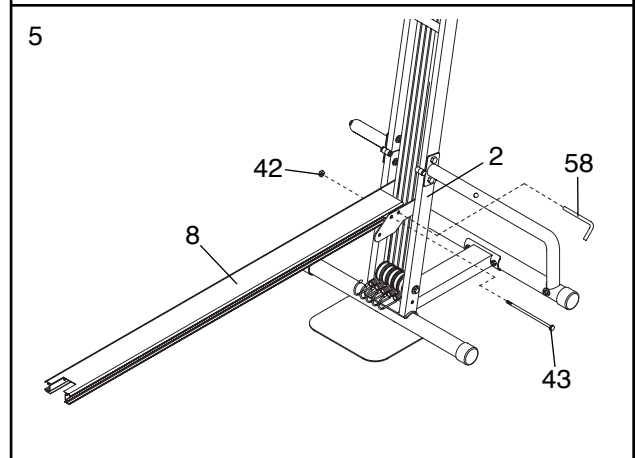

6. Bolt the six Seat Wheels (32) to the inside of the Seat Carriage (11) using six M6 x 33mm Shoulder Bolts (33), six Spacers (60), and six M6 Nylon Locknuts (52). **Note: The Wheels may already be attached to the Seat Carriage.**

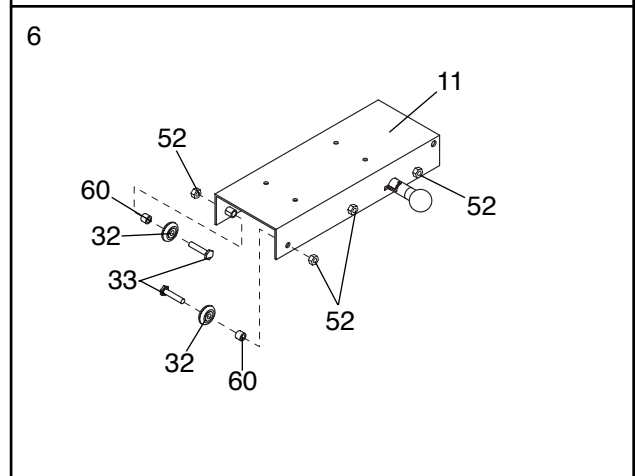

- With the Seat (12) oriented as shown, attach the Seat to the Seat Carriage (11) using four M6 x 16mm Screws (31).

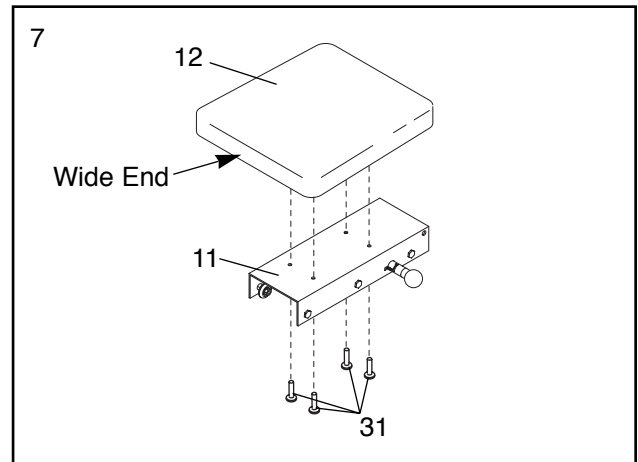

- Slide the Seat (12) onto the Rail (8). **Make sure the Seat is oriented as shown, with the pop pin on the indicated side.**

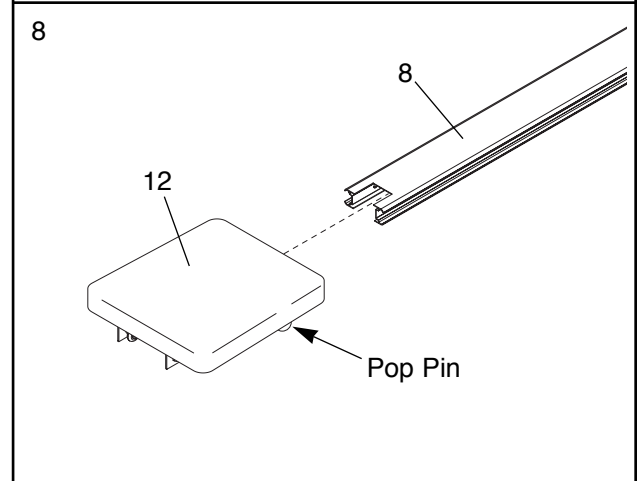

- Press a 50mm Square Inner Cap (47) into the top of the Rail Leg (9). Press the Rail Leg Cap (34) onto the bottom of the Rail Leg. Attach the Bumper (25) to the Rail Leg using an M4 x 16mm Screw (26).

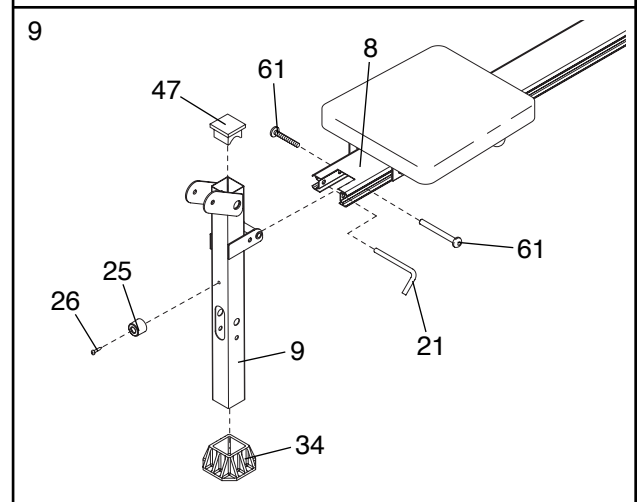

Using the Union Bolt Set (61), attach the Rail Leg (9) to the Rail (8). Do not overtighten the Union Bolt Set. The Rail Leg must be able to pivot freely for storage.

Slide the Short Lock Pin (21) into the other hole in the Rail (8) and the Rail Leg (9). **Press the Lock Pin all the way through the Rail and the Rail Leg.**

- Press a 45mm Square Inner Cap (29) into each end of the Leg Lever (10).

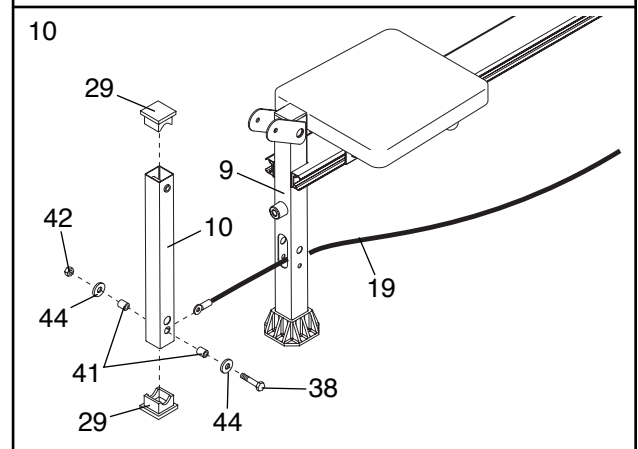

Slide the Short Cable (19) through the indicated hole in the Rail Leg (9). Attach the Short Cable to the Leg Lever (10) using an M10 x 60mm Bolt (38), two M10 Flat Washers (44), two 21mm Spacers (41), and an M10 Nylon Locknut (42).

11. Attach the Leg Lever (10) to the Rail Leg (9) using an M10 x 67mm Bolt (48) and an M10 Nylon Locknut (42).

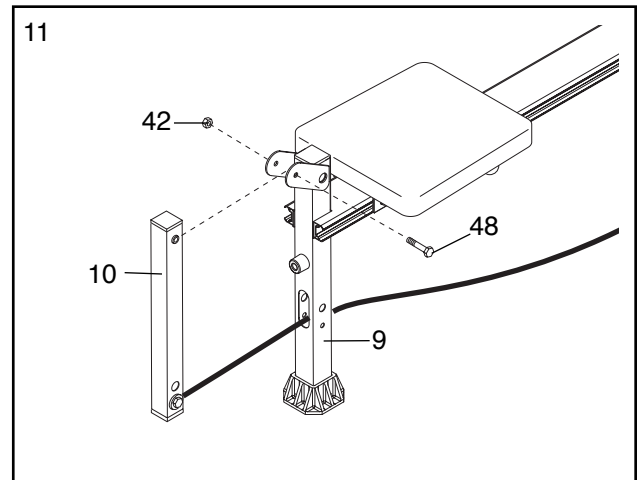

12. Attach the Backrest Rails (22) to the Backrest (13) as indicated using four M6 x 16mm Screws (31). Make sure the Backrest Rails are oriented exactly as shown.

Attach the Backrest Bracket (23) to the Backrest (13) using two M4 x 25mm Screws (57). When attached, the Backrest Bracket should be flush with the ends of the Backrest Rails (22).

With the Backrest (13) oriented as shown, slide the Long Lock Pin (59) through the holes in the Backrest Rails (22) and through the front holes in the Seat Carriage (11).

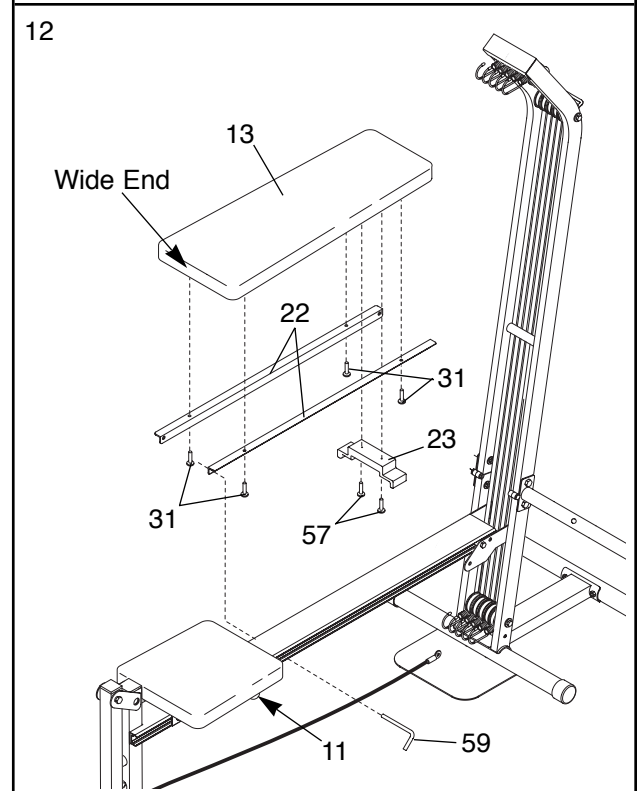

13. Place one end of the Long Cable (18) in a Pulley Bracket (49). Secure one of the three Cable Pulleys (50) to the Pulley Bracket using an M10 x 27mm Bolt (51) and an M10 Nylon Locknut (42). Attach the Pulley Bracket to the Left Brace (5) using an Eyebolt (53) and an M8 Nylon Locknut (37).

Attach a Pulley Bracket (49) and a Cable Pulley (50) to the opposite end of the Long Cable (18) and attach it to the Right Brace (4) in the same manner.

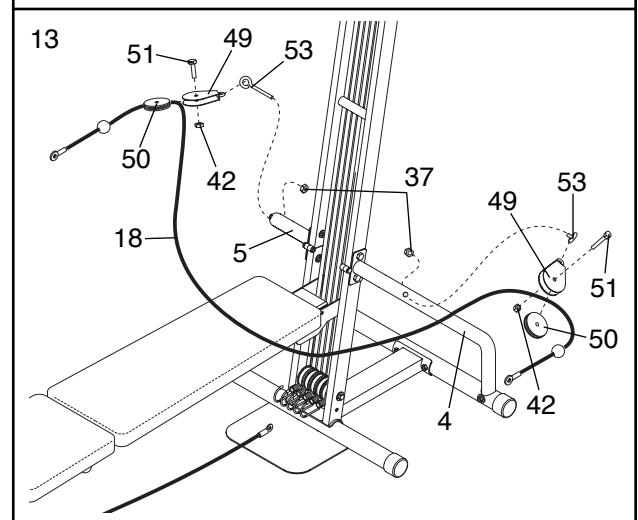

- Route the Long Cable (18) around the remaining Cable Pulley (50). Slide the Cable Pulley into a Pulley Bracket (49) and secure it using an M10 x 27mm Bolt (51) and an M10 Nylon Locknut (42).

Attach the Large Cable Clip (36) and a Cord Ring (16) to the Pulley Bracket (49). Attach the Cord Ring to the hooks at the high pulley station.

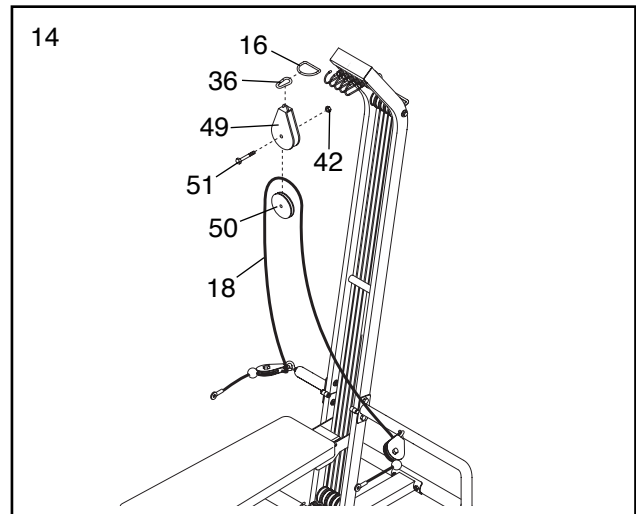

- Slide an M10 x 67mm Bolt (48) with an M10 Flat Washer (44) through the bottom set of holes in the Rail Leg (9). **Make sure the Bolt is under the Short Cable (19).** Secure the Bolt with an M10 Flat Washer (44) and an M10 Nylon Locknut (42).

Slide the Leg Lever Pulley (24) into the hole in the Rail Leg (9). Make sure the Short Cable (19) fits into the groove of the Leg Lever Pulley. Attach the Pulley to the Rail Leg (9) using an M10 x 67mm Bolt (48), two M10 Flat Washers (44), two 12.5mm Spacers (35), and an M10 Nylon Locknut (42).

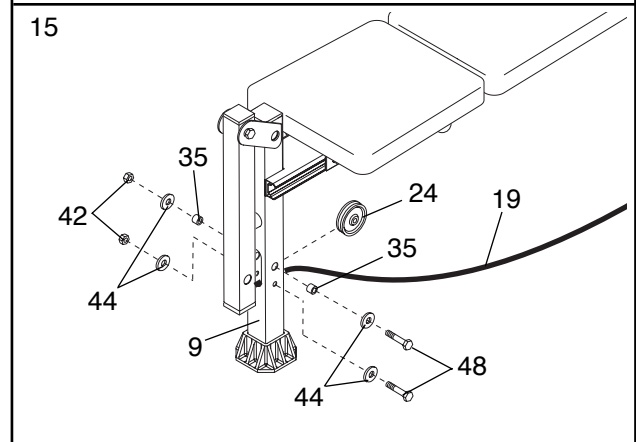

- Press a 3/4" Round Inner Cap (27) into each end of both Pad Tubes (28). Slide the Pad Tubes through the holes in the Rail Leg (9) and the Leg Lever (10). Slide Foam Pads (30) onto the ends of the Pad Tubes.

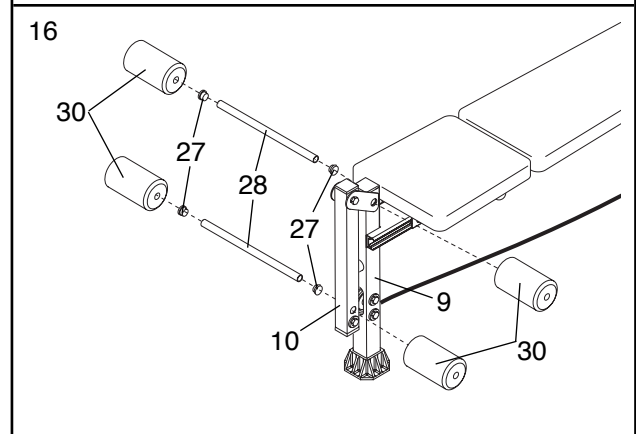

- Press a Handgrip (17) onto each end of the Lat Bar (56).

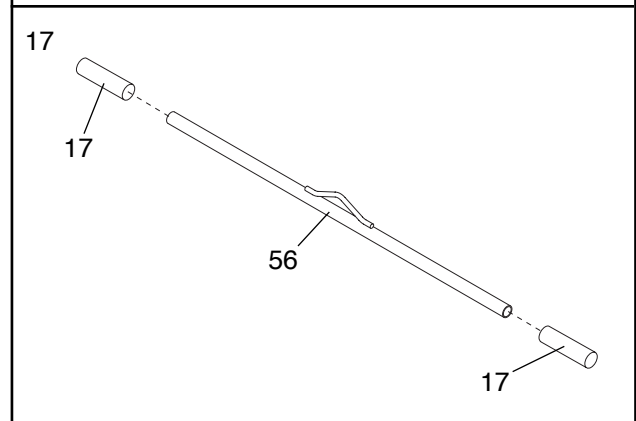

- Make sure all parts are properly tightened. The use of the remaining parts will be explained on pages 11 and 12.**

Adjusting the Weight System

This section explains how to adjust the weight system. See the EXERCISE GUIDELINES on page 14 for important information on how to get the most benefit from your exercise program. Also, refer to the accompanying exercise poster to see the correct form for each exercise.

Inspect and tighten all parts each time you use the weight system. Replace any worn parts immediately. Replace the resistance cords at least every two years. The weight system can be cleaned with a damp cloth and a mild, non-abrasive detergent. Do not use solvents.

ATTACHING THE LAT BAR TO THE HIGH PULLEY STATION

To do exercises requiring the use of the Lat Bar (56), attach it to a Cord Ring (16) using the Large Cable Clip (36). Attach the Cord Ring to as many resistance cords as desired using the hooks at the ends of the cords.

⚠ WARNING: Always remove the Lat Bar (56) when it is not in use.

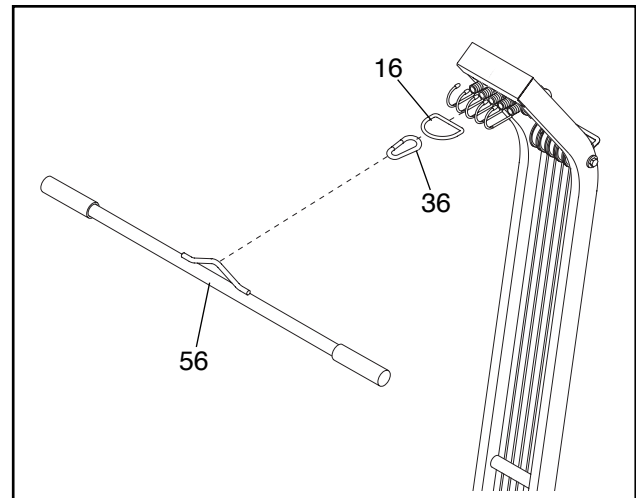

ATTACHING AND REMOVING THE TOP PULLEY

For certain exercises, the top pulley must be attached to the high pulley station. To do this, attach the Large Cable Clip (36) to the top pulley. Attach the Cable Clip to a Cord Ring (16) and attach the Cord Ring to as many hooks as desired.

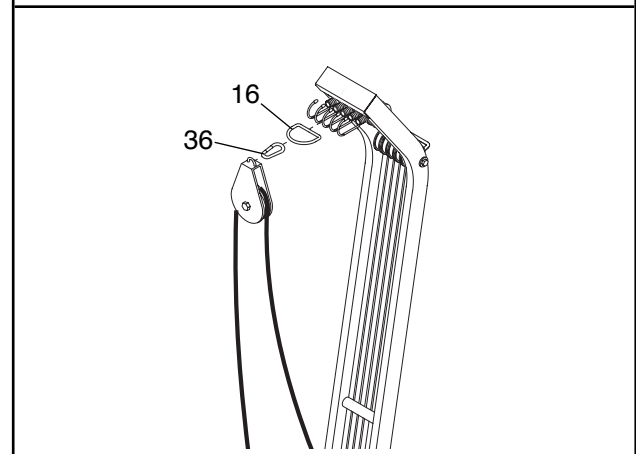

FOLDING THE BENCH

For certain exercises and for storage, the bench should be folded. To fold the bench, remove the Medium Lock Pin (58). Lift the bench in the direction shown by the large arrow. The bench will lock in an upright position. Replace the Medium Lock Pin. Next, remove the Short Lock Pin (21) and pivot the Rail Leg (9) toward the bench. Replace the Short Lock Pin.

To unfold the bench, first extend the Rail Leg (9) and lock it in place with the Short Lock Pin (21). Next, lower the bench in the direction shown by the large arrow and secure it with the Medium Lock Pin (58).

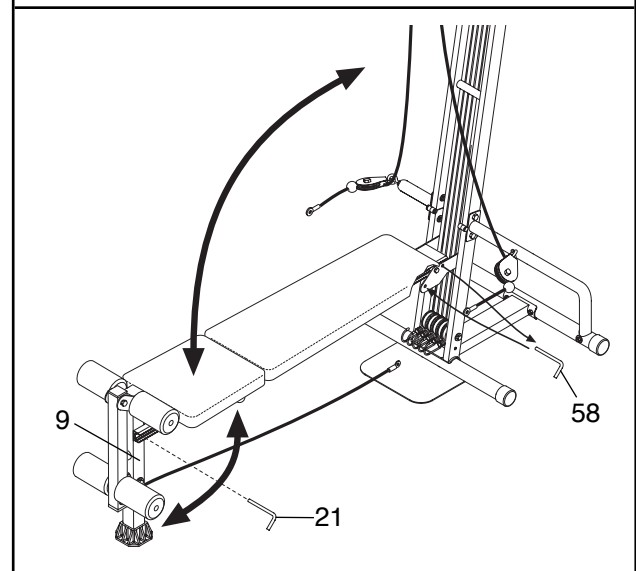

ATTACHING THE HANDLES TO THE LONG CABLE

To use the Handles (39), attach each Handle to a Cable Clip (40), and then attach the Cable Clips to the ends of the Long Cable (18).

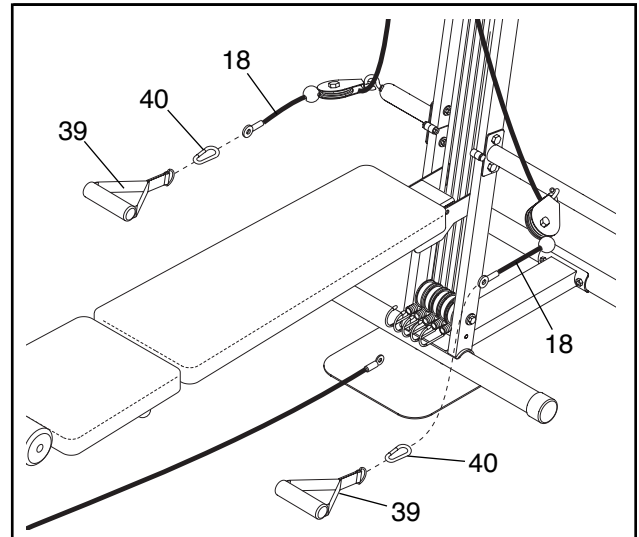

CONNECTING THE SHORT CABLE TO THE LOW PULLEY STATION

To use the Leg Lever (10), the Short Cable (19) must be attached to the low pulley station. To do this, attach the end of the Short Cable to a Cable Clip (40), attach the Cable Clip to a Cord Ring (16), and attach the Cord Ring to as many of the hooks as desired.

For some exercises, a Handle (not shown) can be attached to the Short Cable (19) in the same manner.

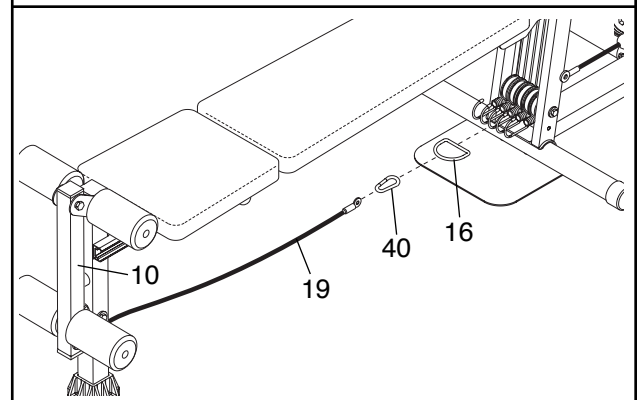

ATTACHING AND REMOVING THE BACKREST

To attach the Backrest (13), slide the Long Lock Pin (59) through the holes in the Backrest Rails (22) and through the front holes in the Seat Carriage (11).

To remove the Backrest (13), pull the Long Lock Pin (59) out of the Backrest Rails (22) and the Seat Carriage (11). Lift the Backrest off the bench.

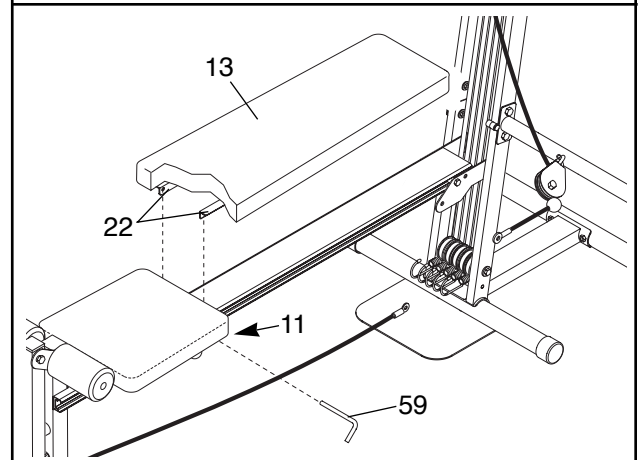

SLIDING THE SEAT

The Seat (12) can slide back and forth for certain exercises. To slide the Seat, pull out the pop pin on the seat carriage and lock it into the open position. The Seat will then slide freely along the Rail (8).

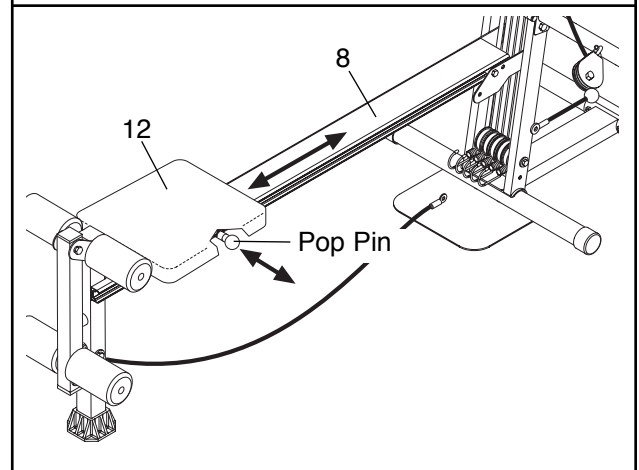

Exercise Guidelines

THE FOUR BASIC TYPES OF WORKOUTS

Muscle Building

The only way to increase the size and strength of your muscles is to push them close to their maximum capacity. When you progressively increase the intensity of your exercise, your muscles will continually adapt and grow. You can tailor each individual exercise to the proper intensity level in two ways:

- by changing the amount of resistance used
- by changing the number of repetitions or sets performed. (A “repetition” is one complete cycle of an exercise, such as one sit-up. A “set” is a series of repetitions.)

The proper amount of resistance for each exercise depends upon the individual user; you must gauge your limits and select the amount of resistance that is right for you. Begin with 3 sets of 8 repetitions for each exercise you perform. Rest for 3 minutes after each set. When you can complete 3 sets of 12 repetitions without difficulty, increase the resistance.

Toning

You can tone your muscles by pushing them to a moderate percentage of their capacity. Select a moderate amount of resistance and increase the number of repetitions in each set. Complete as many sets of 15 to 20 repetitions as possible without discomfort. Rest for 1 minute after each set. Work your muscles by completing more sets rather than by using high resistance.

Weight Loss

To lose weight, use a low amount of resistance and increase the number of repetitions in each set. Exercise for 20 to 30 minutes, resting for a maximum of 30 seconds between sets.

Cross Training

For a complete and well-balanced fitness program, cross training is a very effective. One example of a balanced program is:

- Plan weight training workouts on Monday, Wednesday and Friday.
- Plan 20 to 30 minutes of aerobic exercise, such as cycling or swimming, on Tuesday and Thursday.
- Rest from both weight training and aerobic exercise for at least one full day each week to give your body time to regenerate.

The combination of weight training and aerobic exercise will reshape and strengthen your body and develop your heart and lungs.

PERSONALIZING YOUR EXERCISE PROGRAM

Specifying the exact length of time for each workout, as well as the number of repetitions or sets for each exercise, is a highly individual matter. It is very important to avoid overdoing it during the first few months of your exercise program. You should progress at your own pace and be sensitive to your body's signals. If you experience pain or dizziness at any time while exercising, stop immediately and begin cooling down. Find out what is wrong before continuing. Remember that adequate rest and a proper diet are important factors in any exercise program.

WARMING UP

Begin each workout with 5 to 10 minutes of stretching and light exercise to warm up. Warming up prepares your body for more strenuous exercise by increasing circulation, raising your body temperature and delivering more oxygen to your muscles.

WORKING OUT

Each workout should include 6 to 10 different exercises. Select exercises for every major muscle group with emphasis on the areas that you want to develop the most. To give balance and variety to your workouts, vary the exercises from session to session.

Schedule your workouts for the time of day when your energy level is the highest. Each workout should be followed by at least one day of rest. Once you find the schedule that is right for you, stick with it.

EXERCISE FORM

You will gain the greatest benefits from exercising by maintaining proper form. This requires moving through the full range of motion for each exercise and moving only the appropriate parts of the body. Exercising in an uncontrolled manner will leave you feeling exhausted. On the exercise poster accompanying this manual, you will find photographs showing the correct form for several exercises. A description of each exercise is also provided, along with a list of the muscles affected. Refer to the muscle chart on page 14 to find the locations of the muscles.

The repetitions in each set should be performed smoothly and without pausing. The exertion stage of each repetition should last about half as long as the return stage. Proper breathing is important. Exhale during the exertion stage of each repetition and inhale during the return stroke. Never hold your breath.

Rest for a short period of time after each set. The ideal resting periods are:

- Rest three minutes after each set for a muscle building workout
- Rest one minute after each set for a toning workout
- Rest 30 seconds after each set for a weight loss workout

Plan to spend the first couple of weeks familiarizing yourself with the equipment and learning the proper form for each exercise.

COOLING DOWN

End each workout with 5 to 10 minutes of stretching. Include stretches for both your arms and legs. Move slowly as you stretch and do not bounce. Ease into each stretch gradually and go only as far as you can

without strain. Stretching at the end of each workout is very effective for increasing flexibility.

STAYING MOTIVATED

For motivation, keep a record of each workout. The chart on page 15 can be photocopied and used to schedule and record your workouts. List the date, the exercises performed, the resistance, and the numbers of sets and repetitions completed. Record your weight and key body measurements at the end of every month.

Remember, the key to achieving the greatest results is to make exercise a regular and enjoyable part of your everyday life.

MUSCLE CHART

- A. Sternomastoid (neck)
- B. Pectoralis Major (chest)
- C. Biceps (front of arm)
- D. Obliques (waist)
- E. Brachioradials (forearm)
- F. Hip Flexors (upper thigh)
- G. Abductor (outer thigh)
- H. Quadriceps (front of thigh)
- I. Sartorius (front of thigh)
- J. Tibialis Anterior (front of calf)
- K. Soleus (front of calf)
- L. Rectus Abdominus (stomach)
- M. Adductor (inner thigh)
- N. Trapezius (upper back)
- O. Rhomboideus (upper back)
- P. Deltoid (shoulder)
- Q. Triceps (back of arm)
- R. Latissimus Dorsi (mid back)
- S. Spinae Erectors (lower back)
- T. Gluteus Medius (hip)
- U. Gluteus Maximus (buttocks)
- V. Hamstring (back of leg)
- W. Gastrocnemius (back of calf)

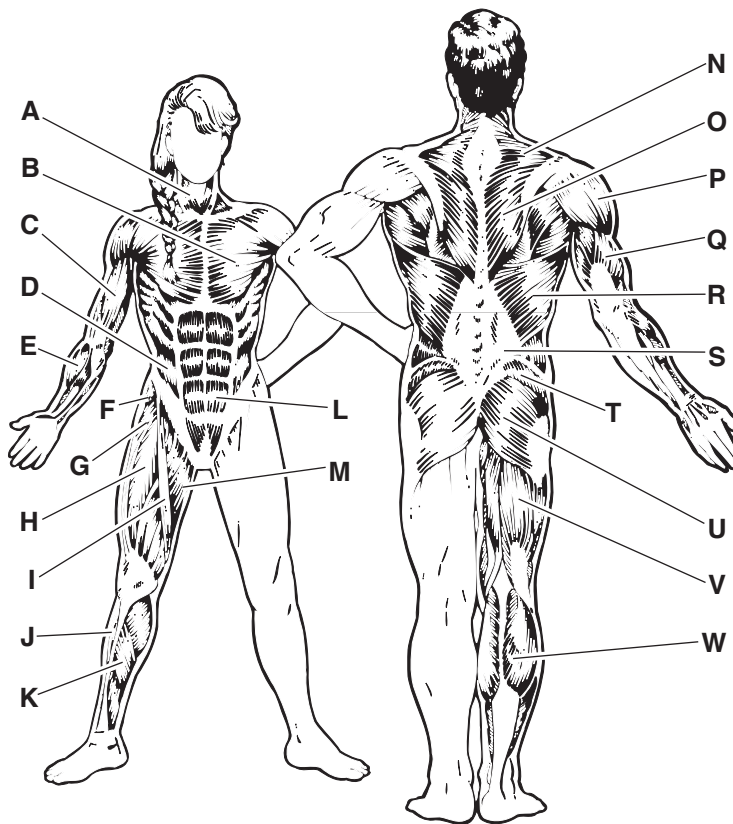

MONDAY Date: _____ / /	EXERCISE	WEIGHT	SETS	REPS

TUESDAY **AEROBIC EXERCISE**
 Date: _____
 / /

WEDNESDAY Date: _____ / /	EXERCISE	WEIGHT	SETS	REPS

THURSDAY **AEROBIC EXERCISE**
 Date: _____
 / /

FRIDAY Date: _____ / /	EXERCISE	WEIGHT	SETS	REPS

Make photocopies of this page for scheduling and recording your workouts.

Part List—Model No. WESY20000

R0900A

Key No.	Qty.	Description	Key No.	Qty.	Description
1	1	Upper Frame	34	1	Rail Leg Cap
2	1	Lower Frame	35	2	12.5mm Spacer
3	1	Rear Stabilizer	36	1	Large Cable Clip
4	1	Right Brace	37	2	M8 Nylon Locknut
5	1	Left Brace	38	1	M10 x 60mm Bolt
6	1	Front Stabilizer	39	2	Handle
7	1	Base	40	3	Cable Clip
8	1	Rail	41	2	21mm Spacer
9	1	Rail Leg	42	23	M10 Nylon Locknut
10	1	Leg Lever	43	1	M10 x 127mm Bolt
11	1	Seat Carriage	44	22	M10 Flat Washer
12	1	Seat	45	2	M10 x 36mm Button Head Bolt
13	1	Backrest	46	4	M10 x 42mm Bolt
14	15	Cord Pulley	47	1	50mm Square Inner Cap
15	5	Resistance Cord	48	7	M10 x 67mm Bolt
16	2	Cord Ring	49	3	Pulley Bracket
17	2	Handgrip	50	3	Cable Pulley
18	1	Long Cable	51	3	M10 x 27mm Bolt
19	1	Short Cable	52	8	M6 Nylon Locknut
20	4	51mm Round Outer Cap	53	2	Eyebolt
21	1	Short Lock Pin	54	3	M10 x 180mm Bolt
22	2	Backrest Rail	55	6	9.2mm Spacer
23	1	Backrest Bracket	56	1	Lat Bar
24	1	Leg Lever Pulley	57	2	M4 x 25mm Screw
25	1	Bumper	58	1	Medium Lock Pin
26	3	M4 x 16mm Screw	59	1	Long Lock Pin
27	4	3/4" Round Inner Cap	60	6	Spacer
28	2	Pad Tube	61	1	Union Bolt Set
29	2	45mm Square Inner Cap	62	1	Pivot Tube
30	4	Foam Pad	#	1	5mm Allen Wrench
31	10	M6 x 16mm Screw	#	1	6mm Allen Wrench
32	6	Seat Wheel	#	1	User's Manual
33	6	M6 x 33mm Shoulder Bolt	#	1	Exercise Poster

Note: “#” Indicates a non-illustrated part. Specifications are subject to change without notice. See the back cover of this manual for information about ordering replacement parts.

Exploded Drawing—Model No. WESY20000

R0900A

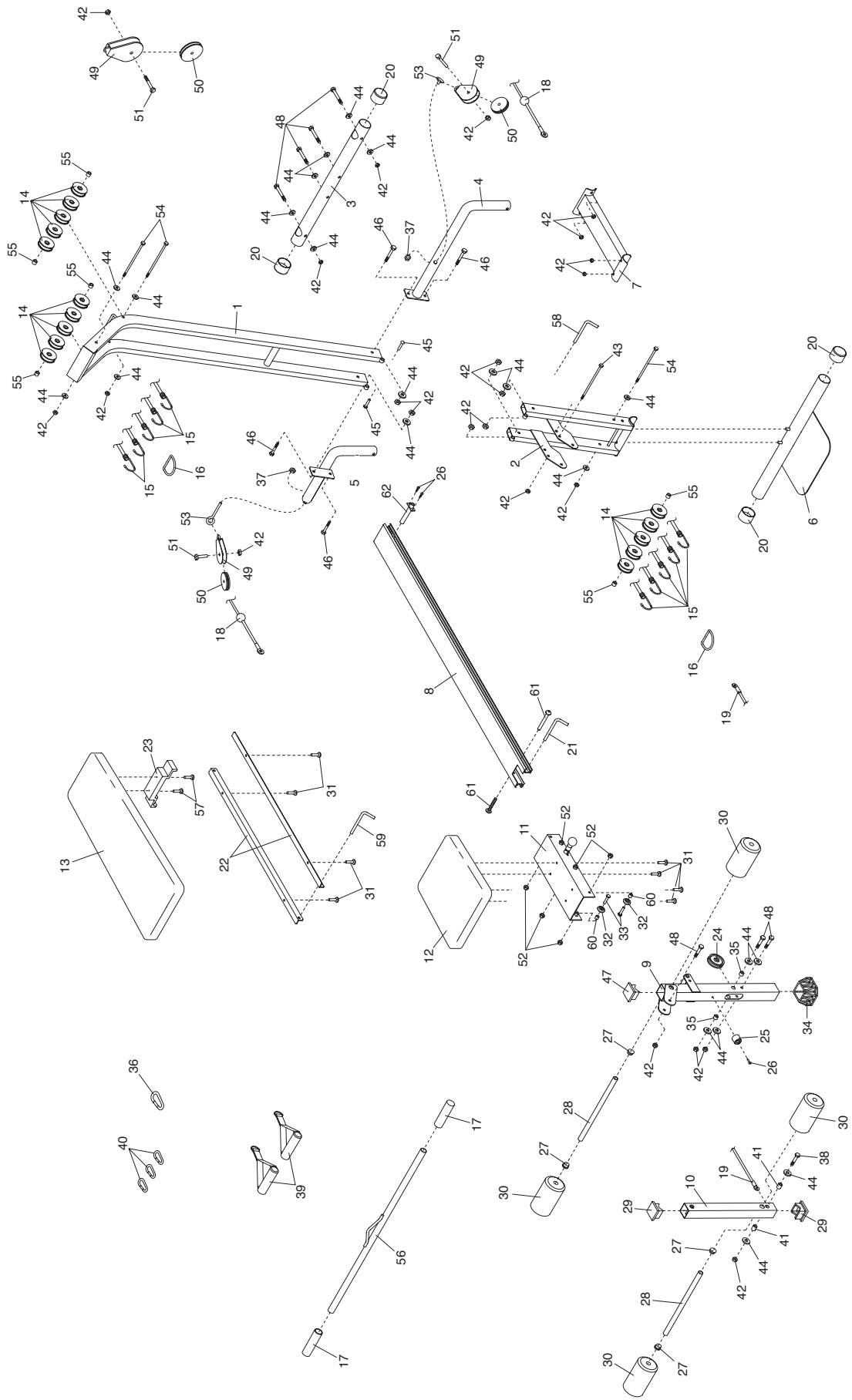

Ordering Replacement Parts

To order replacement parts, simply call our Customer Service Department toll-free at 1-800-999-3756, Monday through Friday, 6 a.m. until 6 p.m. Mountain Time (excluding holidays). To help us assist you, please be prepared to give the following information when calling:

- The MODEL NUMBER of the product (WESY20000)
- The NAME of the product (WEIDER® FLEX GYM 2000)
- The SERIAL NUMBER of the product (see the front cover of this manual)
- The KEY NUMBER and DESCRIPTION of the desired part(s) (see the PART LIST and EXPLODED DRAWING attached in the center of this manual).

Limited Warranty

ICON Health & Fitness, Inc. (ICON), warrants this product to be free from defects in workmanship and material, under normal use and service conditions, for a period of ninety (90) days from the date of purchase. This warranty extends only to the original purchaser. ICON's obligation under this warranty is limited to replacing or repairing, at ICON's option, the product at one of its authorized service centers. All products for which warranty claim is made must be received by ICON at one of its authorized service centers with all freight and other transportation charges prepaid, accompanied by sufficient proof of purchase. All returns must be pre-authorized by ICON. This warranty does not extend to any product or damage to a product caused by or attributable to freight damage, abuse, misuse, improper or abnormal usage or repairs not provided by an ICON authorized service center, products used for commercial or rental purposes, or products used as store display models. No other warranty beyond that specifically set forth above is authorized by ICON.

ICON is not responsible or liable for indirect, special or consequential damages arising out of or in connection with the use or performance of the product or damages with respect to any economic loss, loss of property, loss of revenues or profits, loss of enjoyment or use, costs of removal, installation or other consequential damages of whatsoever nature. Some states do not allow the exclusion or limitation of incidental or consequential damages. Accordingly, the above limitation may not apply to you.

The warranty extended hereunder is in lieu of any and all other warranties and any implied warranties of merchantability or fitness for a particular purpose is limited in its scope and duration to the terms set forth herein. Some states do not allow limitations on how long an implied warranty lasts. Accordingly, the above limitation may not apply to you.

This warranty gives you specific legal rights. You may also have other rights which vary from state to state.

ICON HEALTH & FITNESS, INC., 1500 S. 1000 W., LOGAN, UT 84321-9813