

Model No. WESY7974.0

Serial No. _____

Write the serial number in the space above for future reference.

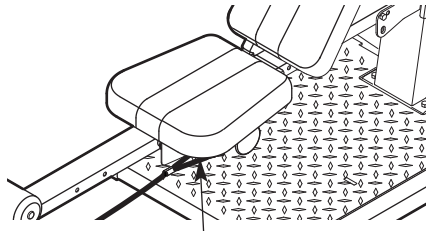

Serial Number Decal (under seat)

QUESTIONS?

As a manufacturer, we are committed to providing complete customer satisfaction. If you have questions, or if a part is damaged or missing, PLEASE CONTACT OUR CUSTOMER SERVICE DEPARTMENT DIRECTLY.

CALL TOLL-FREE:

1-877-992-5999

Mon.–Fri., 6 a.m.–6 p.m. MST

ON THE WEB:

www.weiderservice.com

CAUTION

Read all precautions and instructions in this manual before using this equipment. Save this manual for future reference.



USER'S MANUAL

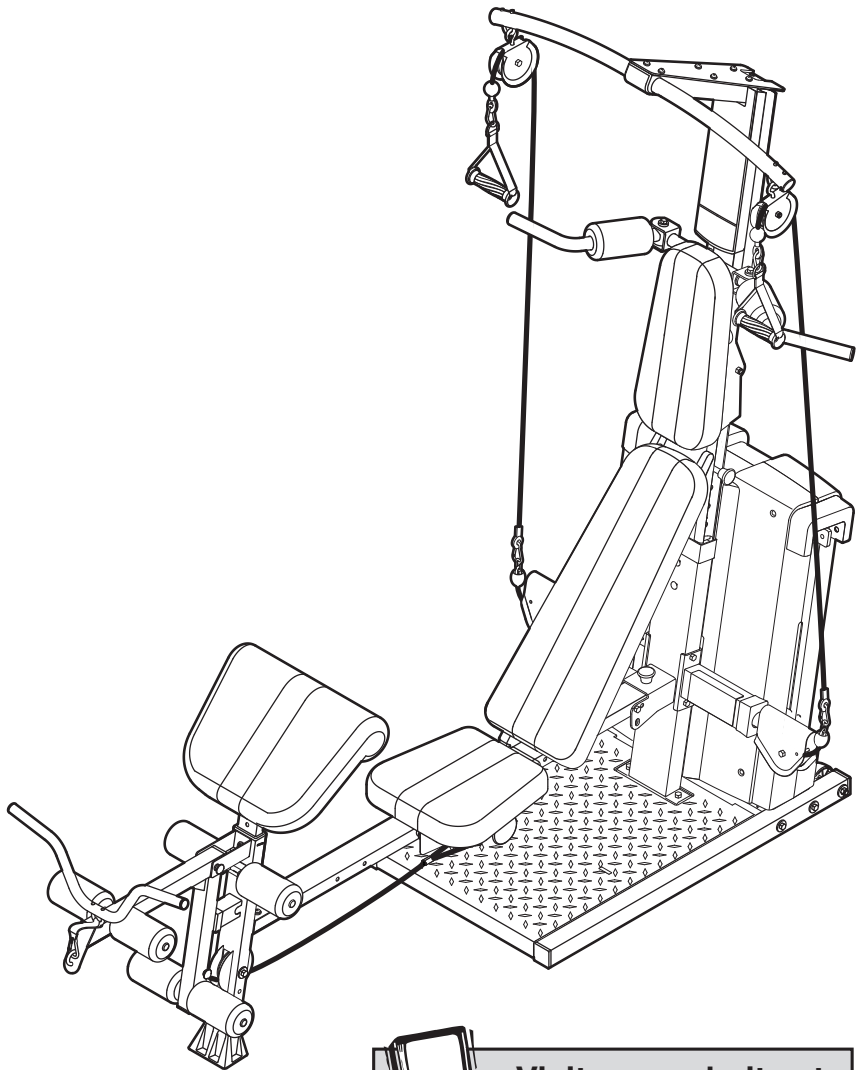

Visit our website at

www.weiderfitness.com

new products, prizes,
fitness tips, and much more!

TABLE OF CONTENTS

WARNING DECAL PLACEMENT	3
IMPORTANT PRECAUTIONS	4
BEFORE YOU BEGIN	5
ASSEMBLY	6
ADJUSTMENTS	16
CONSOLE OPERATION	20
TROUBLESHOOTING	22
EXERCISE GUIDELINES	23
ORDERING REPLACEMENT PARTS	Back Cover
LIMITED WARRANTY	Back Cover

Note: A PART IDENTIFICATION CHART and a PART LIST/EXPLODED DRAWING are attached in the center of this manual. Remove the PART IDENTIFICATION CHART and PART LIST/EXPLODED DRAWING before beginning assembly.

WARNING DECAL PLACEMENT

The decals shown here have been placed on the resistance system. If a decal is missing or illegible, call the toll-free telephone number on the front cover of this manual and order a free replacement decal. Apply the decal in the location shown.

⚠ WARNING
Keep hands and fingers clear of this area.

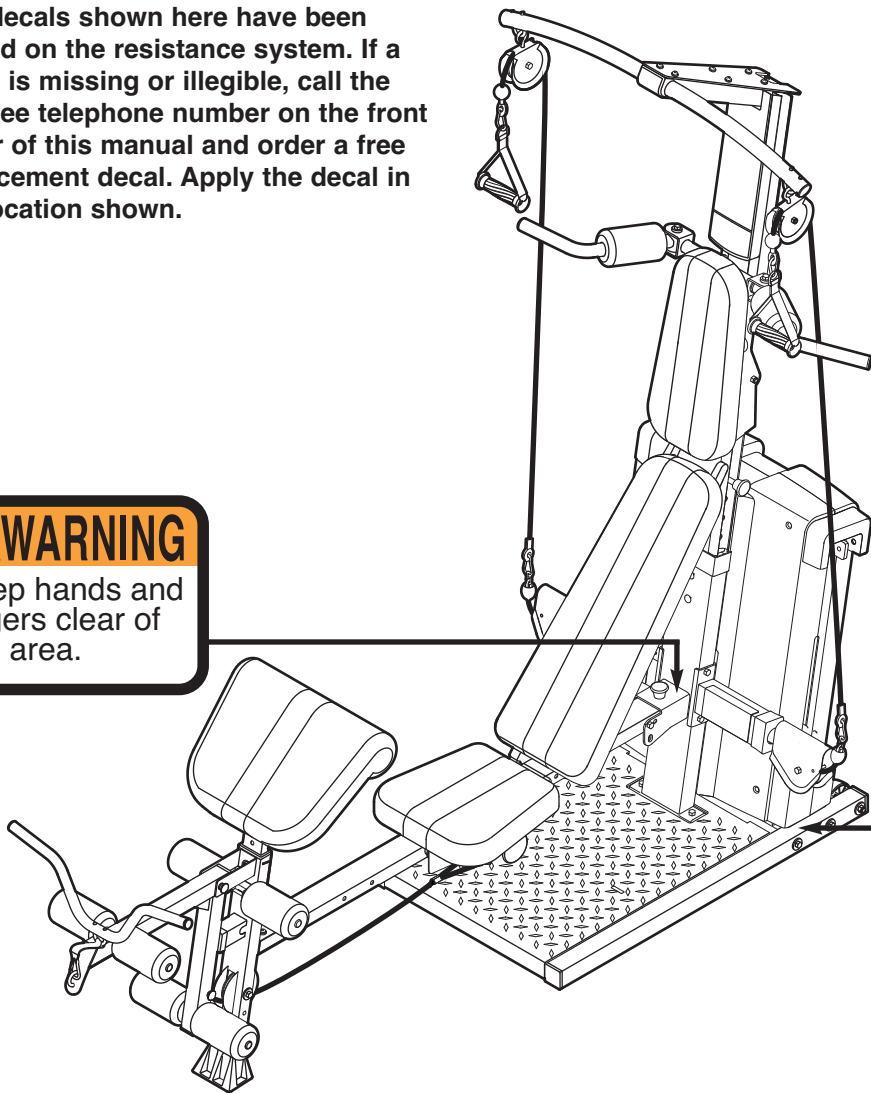

⚠ WARNING

- Misuse of this machine may result in serious injury.
- Read user's manual prior to use and follow all warnings and instructions.
- Do not allow children on or around machine.
- Keep body, clothing, and hair free and clear of all moving parts.
- Replace label if damaged, illegible, or removed.

IMPORTANT PRECAUTIONS

⚠️ WARNING: To reduce the risk of serious injury, read the following important precautions before using the resistance system.

1. Read all instructions in this manual and all warnings on the resistance system before using the resistance system. Use the resistance system only as described in this manual.
2. It is the responsibility of the owner to ensure that all users of the resistance system are adequately informed of all precautions.
3. The resistance system is intended for home use only. Do not use the resistance system in any commercial, rental, or institutional setting.
4. Keep the resistance system indoors, away from moisture and dust. Place the resistance system on a level surface, with a mat beneath it to protect the floor or carpet. Make sure that there is enough clearance around the resistance system to mount, dismount, and use the resistance system.
5. Inspect and properly tighten all parts regularly. Replace any worn parts immediately.
6. Keep children under 12 and pets away from the resistance system at all times.
7. Keep hands and feet away from moving parts.
8. Always wear athletic shoes for foot protection while exercising.
9. The resistance system is designed to support a maximum user weight of 300 pounds.
10. The top frame is not designed to be used for pull-up exercises. Do not hang on the top frame.
11. Pull on the lower cable only while sitting on the bench or standing on the base plate. Pull on the high cables only while sitting on the bench, with the seat in one of the three positions closest to the upright base, or while standing on the base plate.
12. The resistance system is designed to be used with the included resistance, or the resistance included with a WEIDER MAX PACK. Do not use the resistance system with any other type of resistance.
13. Always disconnect the lat bar from the high cables when performing an exercise that does not require it.
14. Make sure the storage knob is in place and fully tightened each time the resistance system is used.
15. Make sure that the cables remain on the pulleys at all times. If the cables bind as you are exercising, stop immediately and make sure that the cables are on the pulleys. Replace all cables at least every two years.
16. Always make sure the two screws in the rope clamps are fully tightened each time the resistance system is used.
17. Do not pull on the cables while the resistance level is being adjusted.
18. If you feel pain or dizziness while exercising, stop immediately and begin cooling down.

⚠️ WARNING: Before beginning this or any exercise program, consult your physician. This is especially important for persons over the age of 35 or persons with pre-existing health problems. Read all instructions before using. ICON assumes no responsibility for personal injury or property damage sustained by or through the use of this product.

BEFORE YOU BEGIN

Thank you for selecting the innovative PLATINUM PLUS BY WEIDER® resistance system. The resistance system offers a selection of stations designed to develop every major muscle group of the body. Whether your goal is to tone your body, build dramatic muscle size and strength, or improve your cardiovascular system, the resistance system will help you to achieve the specific results you want.

For your benefit, read this manual carefully before using the resistance system. If you have questions after reading this manual, see the front cover of this

manual. To help us assist you, please note the product model number and serial number before calling. The model number is WESY7974.0. The serial number can be found on a decal attached to the resistance system (see the front cover of this manual).

To avoid a registration fee for any service needed under warranty, you must register the resistance system at www.weiderservice.com/registration.

Before reading further, please review the drawing below and familiarize yourself with the parts that are labeled.

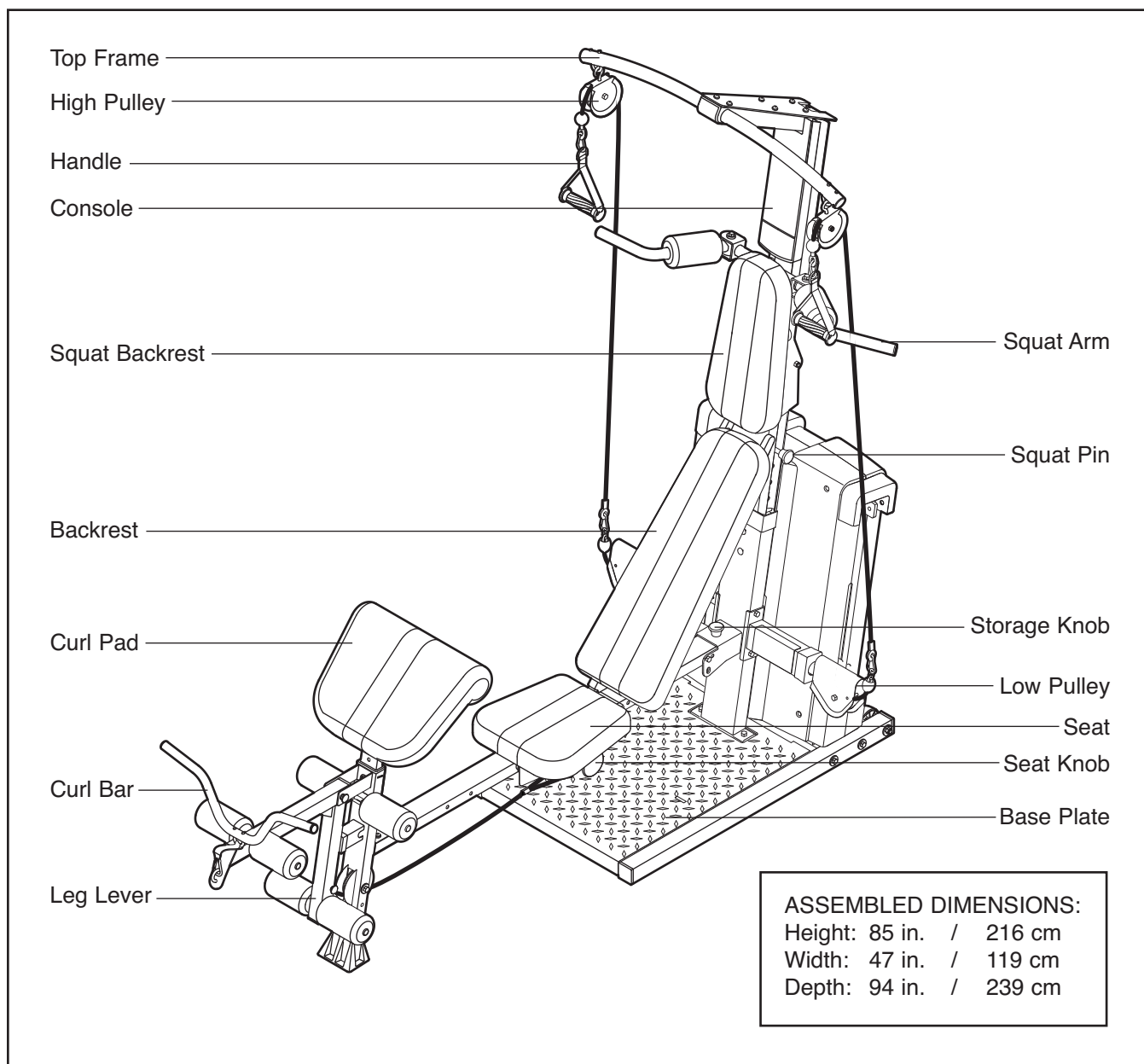

ASSEMBLY

Make Things Easier for Yourself





This manual is designed to ensure that the resistance system can be assembled successfully by most people. However, it is important to realize that the versatile resistance system has many parts and that the assembly process will take time. Most people find that by setting aside plenty of time, assembly will go smoothly.

Before beginning assembly, carefully read the following information and instructions:

- Assembly requires two persons.
- Place all parts in a cleared area and remove the packing materials. Do not dispose of the packing materials until assembly is completed.
- **For help identifying small parts, use the PART IDENTIFICATION CHART.** Note: Some small parts may have been pre-attached for shipping. If a part is not in the parts bag, check to see if it has been pre-attached.

- Tighten all parts as you assemble them, unless instructed to do otherwise.
- As you assemble the resistance system, make sure all parts are oriented as shown in the drawings.

The included hex keys and the following tools (not included) are required for assembly:

- Two adjustable wrenches 
- One rubber mallet 
- One standard screwdriver 
- One Phillips screwdriver 
- Lubricant, such as grease or petroleum jelly, tape, and soapy water.

Assembly will be more convenient if you have a socket set, a set of open-end or closed-end wrenches, or a set of ratchet wrenches.

1. **Before beginning assembly, make sure that you have read and understand the information in the box above. Refer to the PART IDENTIFICATION CHART for help identifying small parts.**

Attach four Plastic Base Feet (71) to the Base (1) with four M4 Washers (157) and four M4 x 16mm Self-tapping Screws (104).

Attach a Wheel (49) to the Base (1) with an M8 x 90mm Shoulder Bolt (125), two M8 Washers (152), and an M8 Nylon Jamnut (139). **Repeat with the other Wheel.**

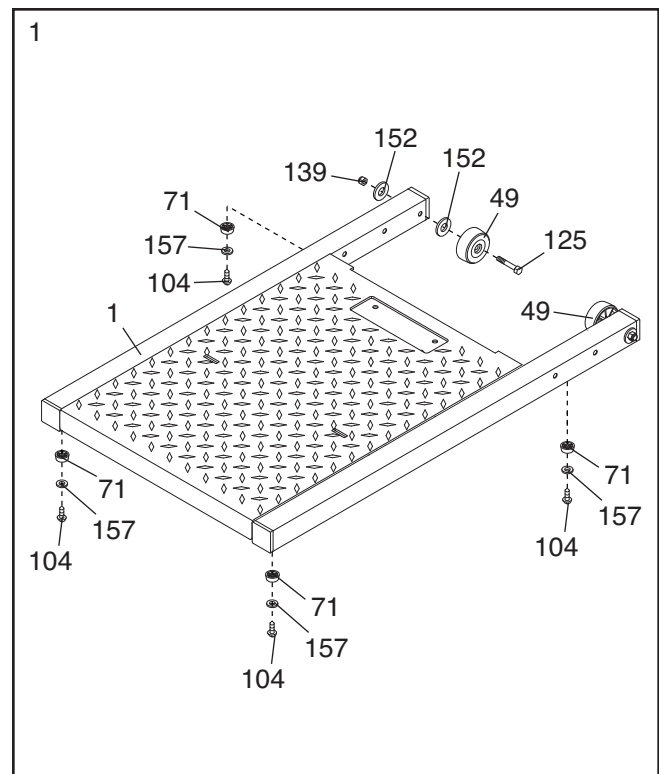

- Insert two M10 x 65mm Carriage Bolts (103) up through the Base (1). **Place a piece of tape over the Bolt heads to hold them in place.** Connect the Upright Base (2) to the Base with the two Carriage Bolts and two M10 Nylon Locknuts (112). **Do not tighten these Locknuts yet.**

Connect the Upright Base (2) to the Base (1) with two M10 x 67mm Bolts (111) and two M10 Nylon Locknuts (112). **Fully tighten these Locknuts.**

Set the Mech Frame (124) onto the Base (1) behind the Upright Base. Handtighten two M10 x 73mm Screws (137) and two M10 Washers (129) into the indicated holes in the Base and Mech Frame. **Note: The Mech Frame will not be shown in the following drawings for clarity.**

Note: One end of the Rope (70) is connected to the Right Arm Frame (171). Untie the loose end of the Rope and route it through the Upright Base (2). **Make sure the loose end of the Rope is still between the 90mm Thin Pulley (88) and Cable Trap (78) (see the inset drawing), and that it crosses under the connected end of the Rope.**

Insert two M14 x 155mm Bolts (107) through the Right Arm Frame (171) and the Upright Base (2). Hand tighten two M14 Nylon Locknuts (127) onto the Bolts.

- Route the loose end of the Rope (70) through the Left Arm Frame (8) and a Swivel Arm (29). Make sure the Rope is under the indicated rod in the Swivel Arm.

Attach the Swivel Arm (29) to the Left Arm Frame (8) with an M4 x 5mm Self-tapping Screw (176).

Attach a "V"-pulley (93) inside the Swivel Arm (29) with an M10 x 53mm Button Bolt (140) and an M10 Nylon Locknut (112).

- Route the loose end of the Rope (70) through a Rope Cover (169) and a Link (167) as shown. **Make sure the large hole in the Rope Cover is on the side shown.** Secure the set of Rope Clamps (165, 166) on the Rope with two M5 x 16mm Button Screws (164). **Make sure that Rope is in the grooves of the Rope Clamps, that there is 1/2" between the Link and the Rope Clamps, and that the two Screws are fully tightened.** Slide the Rope Cover over the Rope Clamps.

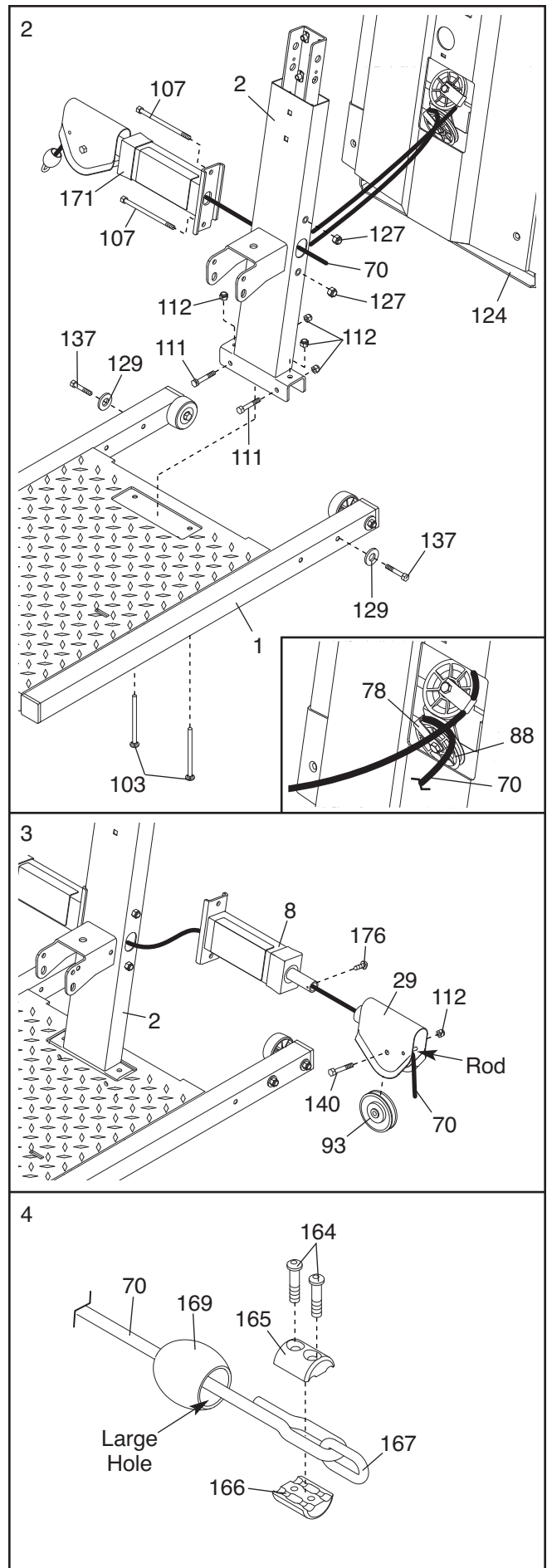

5. Remove the two M14 Nylon Locknuts (127). Attach the Left Arm Frame (8) to the Upright Base (2) with the two M14 x 155mm Bolts (107) used in step 2 and the two M14 Nylon Locknuts.

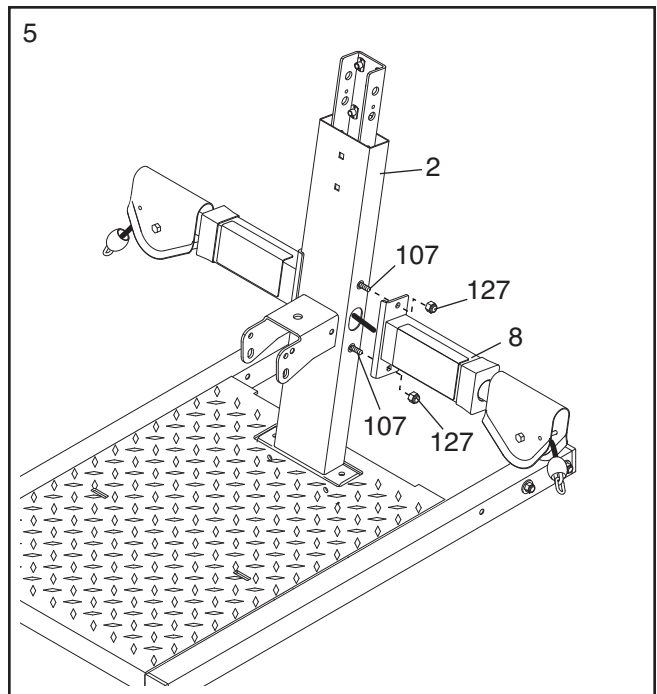

6. Attach the Backing Plate (59) to the Upright Base (2) with two M10 x 65mm Carriage Bolts (103) and two M10 Nylon Locknuts (112). **Do not tighten the Locknuts yet.**

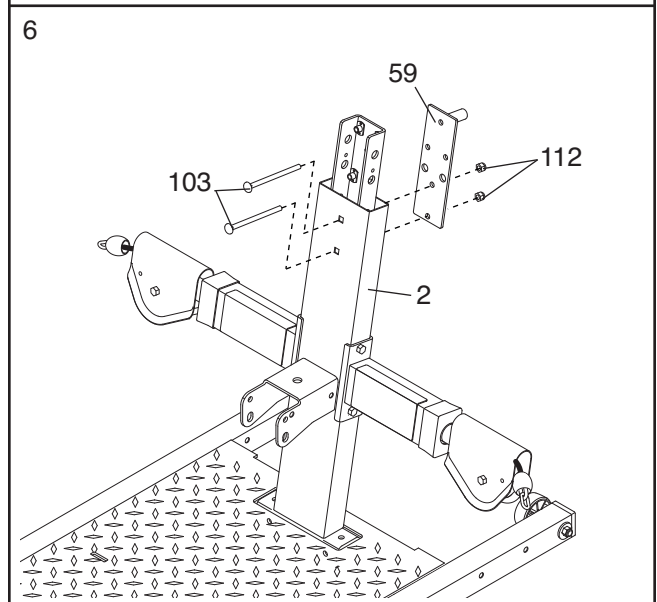

7. Attach the Squat Backrest (28) to the Squat Carriage (10) with four M6 x 16mm Screws (108).

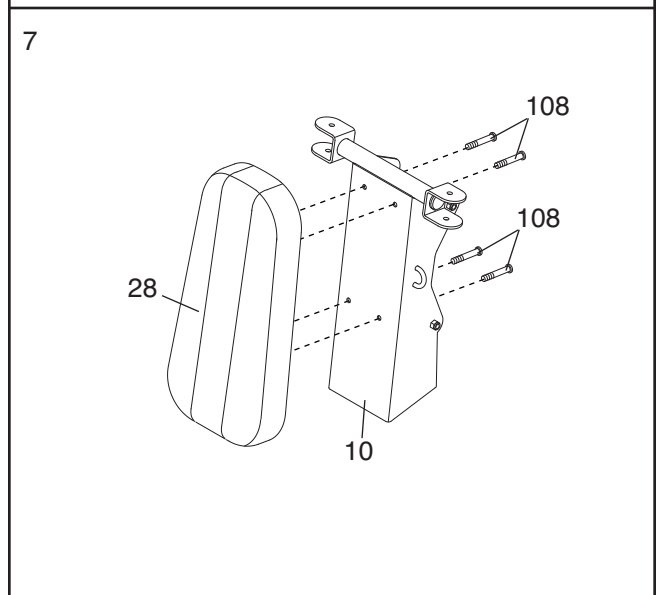

- Slide the Squat Carriage (10) onto the Upright (3) as shown. Insert the Squat Pin (35) into an upper hole in the Upright.

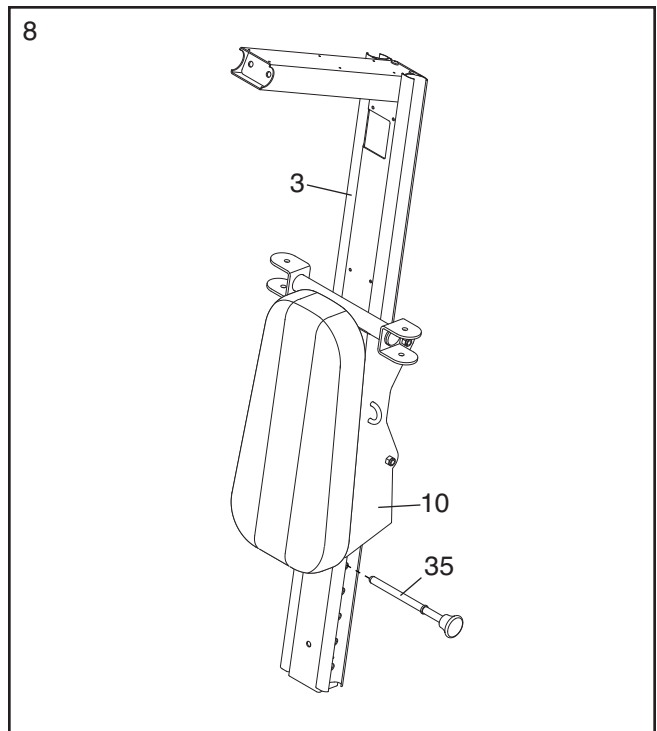

- Press the Front Cover (31) onto the Upright Base (2). **Make sure the Cover is oriented as shown in the inset drawing.**

Route the Upper Wire Harness (172) down through the Upright Base (2) and out the large round hole in the back, as shown.

Slide the Upright (3) onto the Upright Base (2). **Make sure you do not pinch the Upper Wire Harnesses (172).** Secure the Upright with two M10 Washers (129), two M10 x 20mm Screws (113), and two M10 x 25mm Screws (105). **Do not tighten the Screws yet.**

Connect the Upper Wire Harness (172) to the Lower Wire Harness (173) extending from the Mech Frame (not shown). **The connector should slide easily into the socket and snap into place.** If the connector does not slide easily and snap into place, turn it over and then insert it. **IF THE CONNECTOR IS NOT INSERTED PROPERLY, THE CONSOLE MAY BE DAMAGED WHEN THE POWER IS TURNED ON.** Press the excess wire into the Upright Base.

Tighten two M4 x 16mm White ZP Self-tapping Screws (159) into the Upright (3).

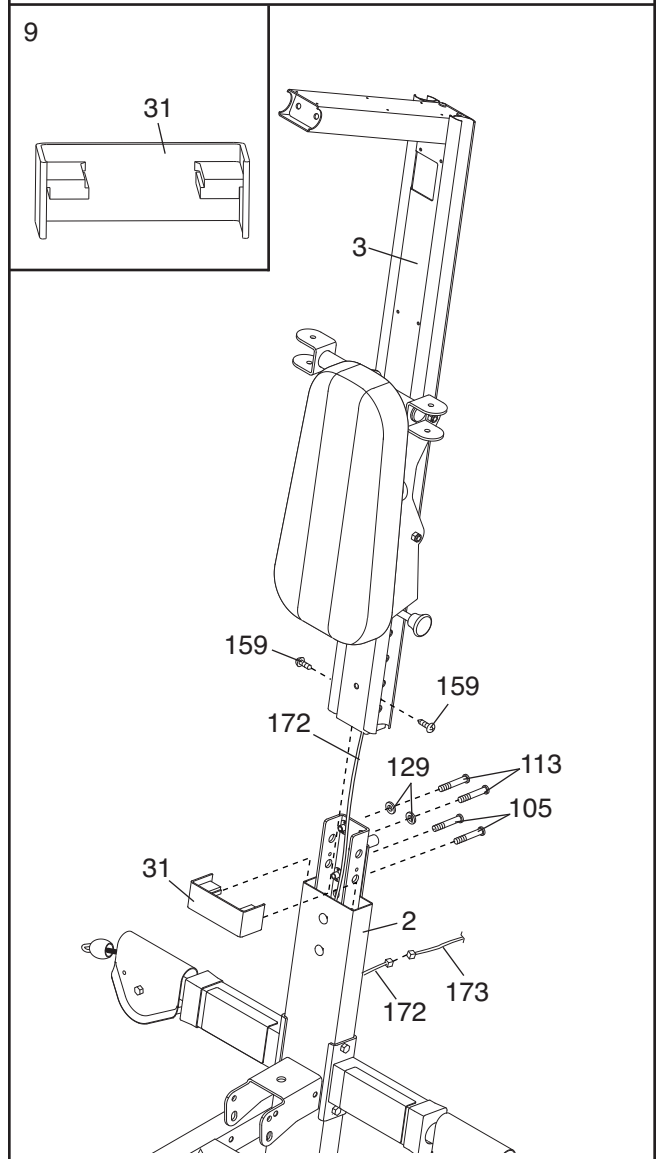

10. Insert an M10 x 125mm Button Screw (144) through an M10 Washer (129), the Upright (3), and the Backing Plate (not shown). **Hold the Bolt in place by sticking a piece of tape over the bolt head.**

Tighten the two M10 Nylon Locknuts (112) used in step 6. Tighten the two M10 x 20mm Screws (113) and two M10 x 25mm Screws (105) used in step 9.

Attach the Mech Frame (124) to the Base (1) with two M10 x 73mm Bolts (137) and two M10 Washers (129). **Do not tighten the Bolts yet.**

Attach the Mech Frame (124) to the Upright (3) with the M10 x 125mm Button Screw (144). **Make sure the Upright and Mech Frame are properly aligned before tightening the Screw.**

Tighten the four M10 x 73mm Bolts (137) in the Base (1) and the two M10 Nylon Locknuts (112) used in the first paragraph of step 2.

Snap the Side Mech Cover (81) into place on the Mech Covers (14 and 15).

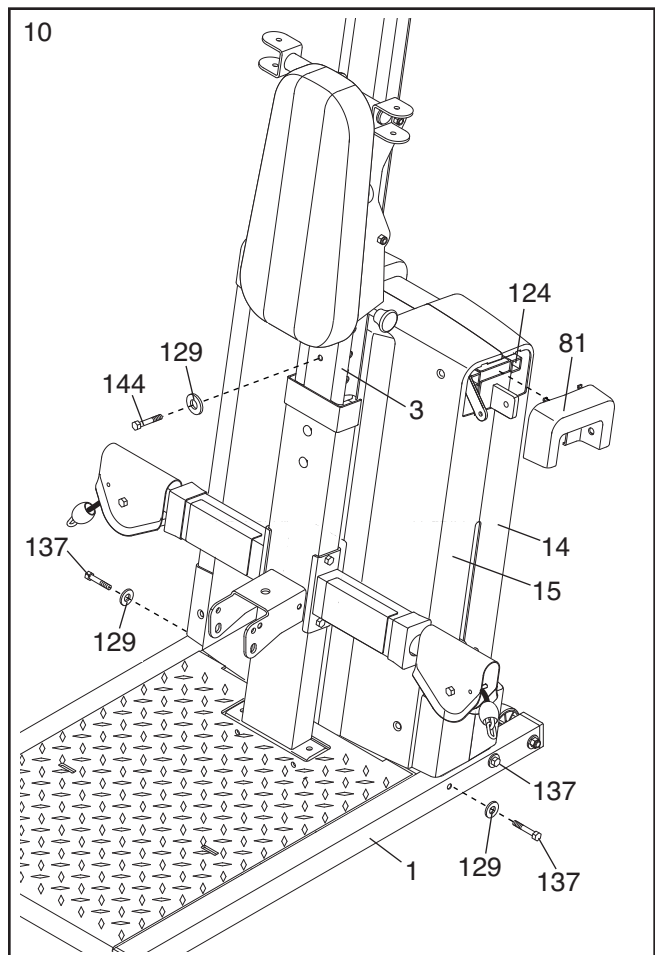

11. Wet a Squat Arm (18) and the inside of a Small Foam Pad (36) with soapy water. Slide the Foam Pad onto the Squat Arm.

Grease an M10 x 73mm Bolt (137). Attach a Squat Arm (18) to the Squat Carriage (10) with the Bolt, two 24mm Plastic Washers (110), and an M10 Nylon Locknut (112). **Do not overtighten the Locknut; the Squat Arm should be able to pivot with intermediate effort.**

Repeat this step with the other Squat Arm (18).

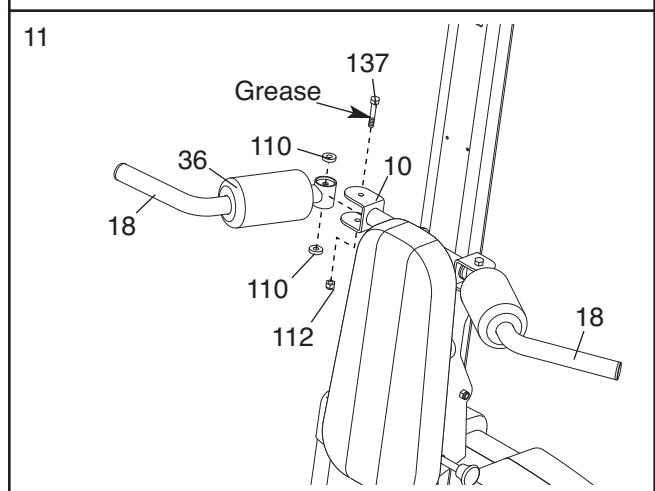

12. Orient the Top Frame (20) with the mark in the position shown. Attach the Top Frame to the Upright (3) with two M10 x 65mm Button Screws (117) and two M10 Washers (129). Press the Plastic Cap (46) into the Upright, over the Top Frame.

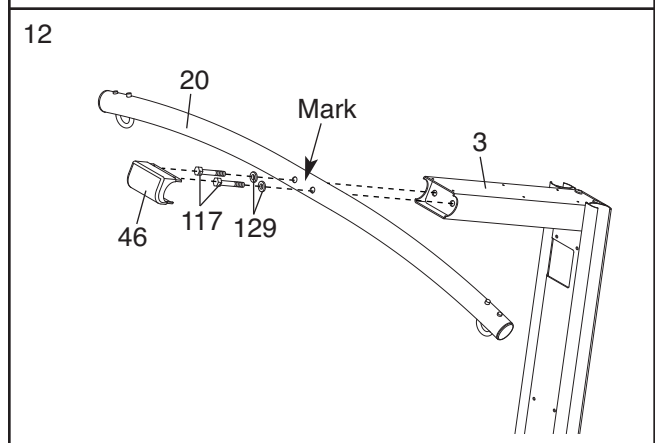

13. Attach the Upright Plate (23) to the Upright (3) with six M4 x 9mm Self-tapping Screws (106).

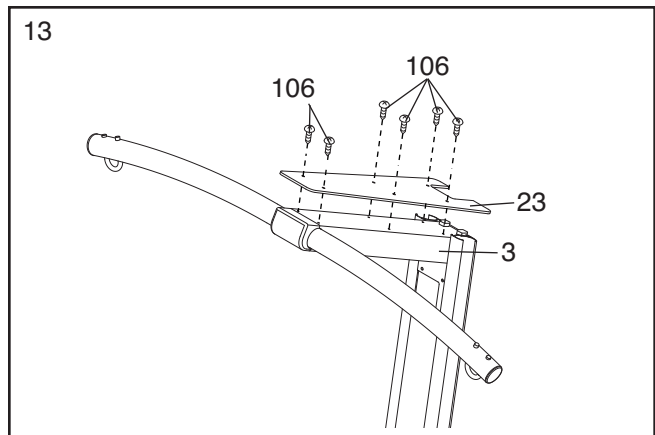

14. Attach the Console (21) to the Upper Wire Harness (172). **The connector should slide easily into the socket and snap into place.** If a connector does not slide easily and snap into place, turn it over and then insert it. **IF THE CONNECTOR IS NOT INSERTED PROPERLY, THE CONSOLE MAY BE DAMAGED WHEN THE POWER IS TURNED ON.** Push the excess wire into the Upright (3).

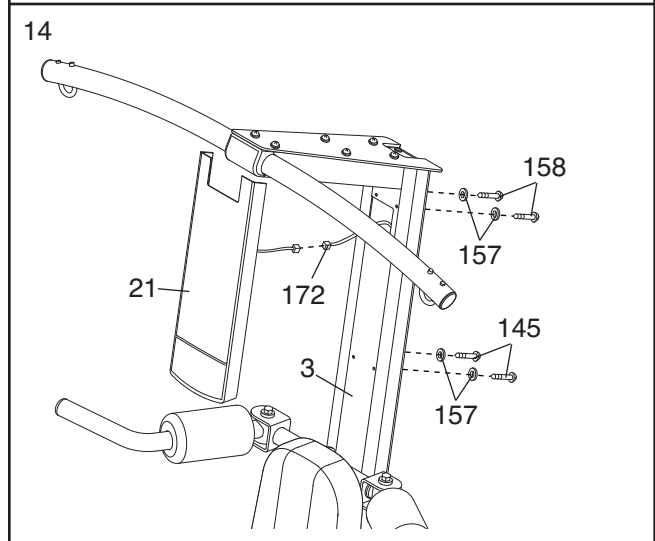

Attach the Console (21) to the Upright (3) with two M4 x 80mm Self-tapping Screws (145), two M4 x 65mm Self-tapping Screws (158), and four M4 Washers (157).

15. Orient the Rail (5) with the holes on the side shown. Attach the Rail to the Upright Base (2) with an M10 x 106mm Bolt (19) and an M10 Nylon Locknut (112). **Do not overtighten the Locknut; the Rail must be able to pivot easily.**

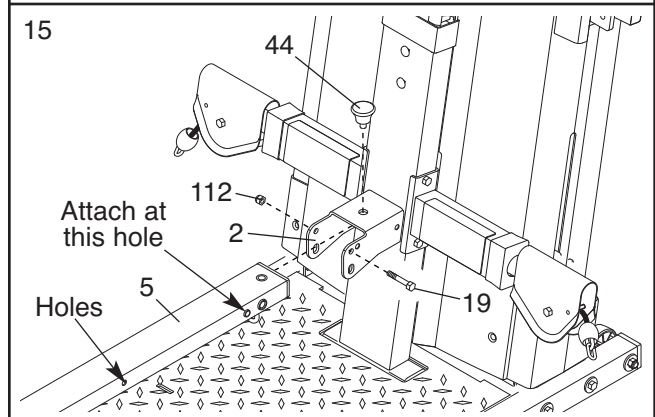

Tighten the Storage Knob (44) into the Upright Base (2) and the Rail (5).

16. Orient the Seat (25) as shown. Attach the Seat to the Seat Carriage (16) with four M6 x 16mm Screws (108).

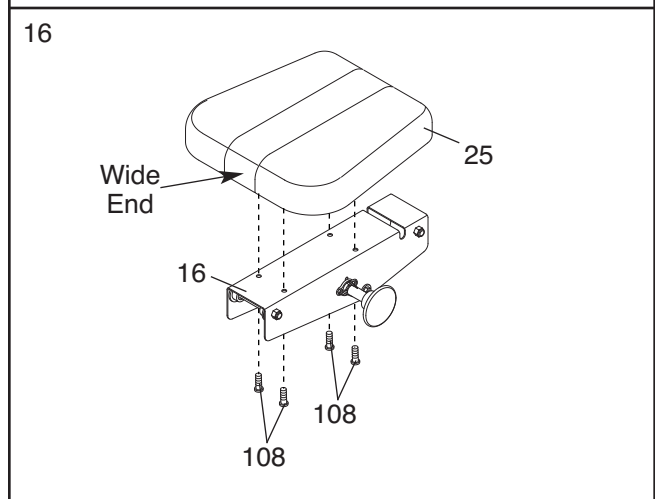

17. Press the Front Leg Foot (38) onto the Front Leg (4). **Note: The front of the Front Leg Foot is taller than the back of the Foot.**

Attach the Front Leg (4) to the Rail (5) with four M8 x 20mm Screws (95) and four M8 Washers (152).

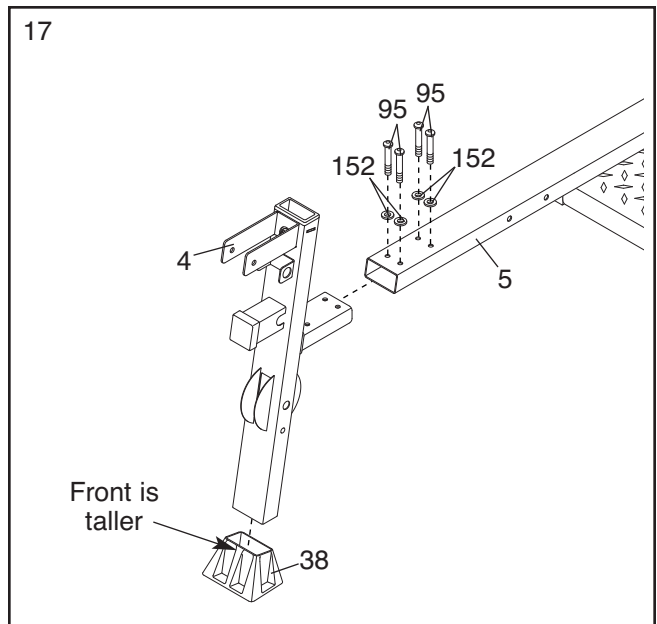

18. Pull out the Seat Knob (138) as far as it will go, and set the Seat Carriage (16) on the Bench Rail (5).

Loosely attach two 8mm Spacers (123), a 59mm Spacer (122), and two Seat Wheels (74) to the bottom holes in the Seat Carriage (16) with an M8 Nylon Jamnut (139) and an M8 x 102mm Bolt (119). **Make sure the parts are oriented as shown in the inset drawing.**

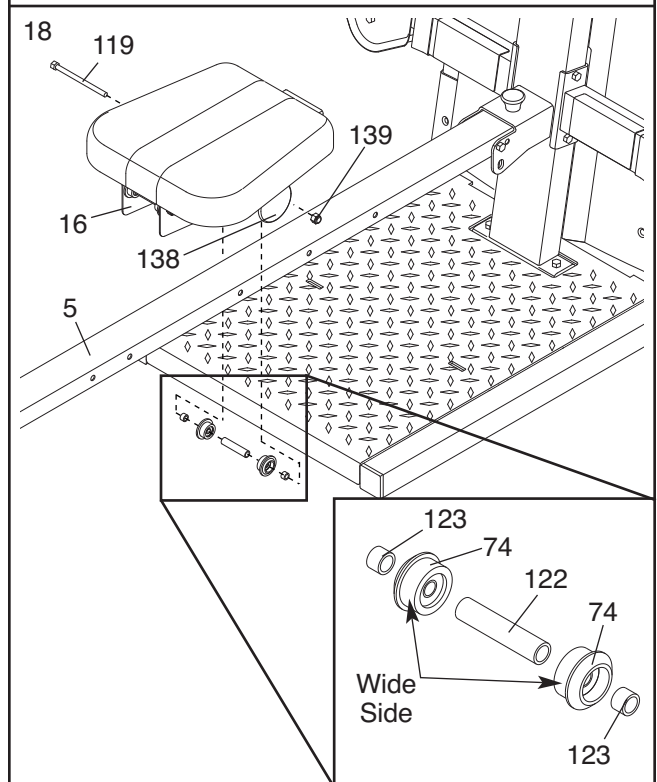

19. **Make sure that the wide sides of all six Seat Wheels (74) are pressed against the Rail (5).** While a second person presses down on the Seat (25), hold the bottom Seat Wheels firmly against the bottom of the Rail and properly tighten the indicated M8 Nylon Jamnut (139).

Engage the Seat Knob (138) into an adjustment hole in the Rail (5).

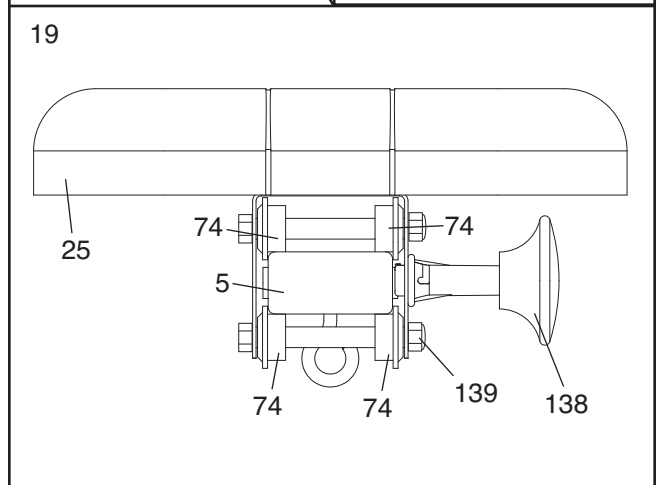

20. Attach the Leg Lever (13) to the Front Leg (4) with a Leg Lever Pin (91) and a Cotter Pin (90).

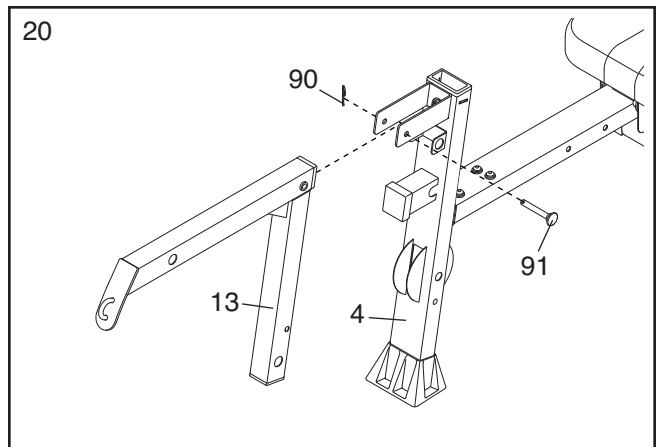

21. Route the short end of the Split Cable (72) through the Front Leg (4) and attach it inside the Leg Lever (13) with a Leg Lever Pin (91) and a Cotter Pin (90).

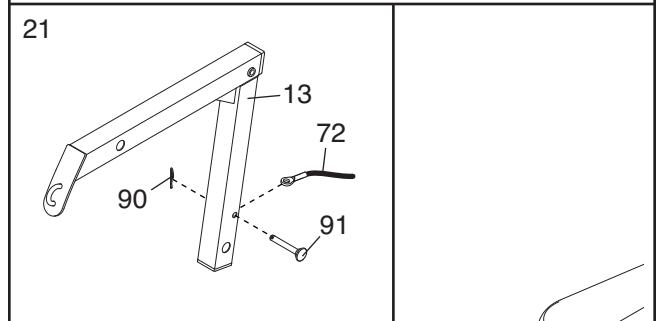

Attach a 90mm Pulley (92) inside the Front Leg (4), over the Split Cable (72), with an M10 x 92mm Bolt (116), two M10 Washers (129), two 25mm Spacers (130), and an M10 Nylon Locknut (112).

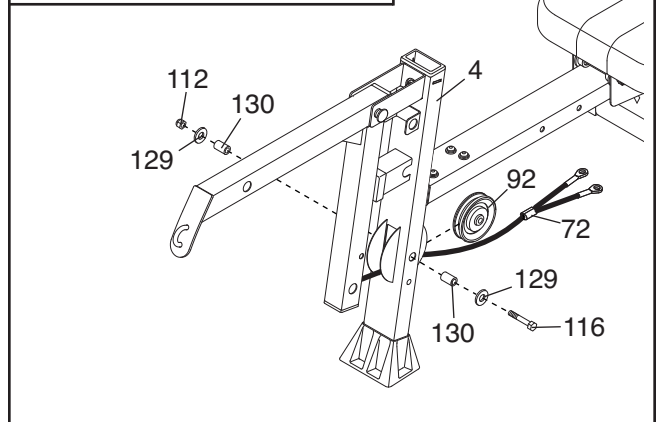

22. Insert the two Short Pad Tubes (32) into the Leg Lever (13). Slide two Large Foam Pads (37) onto each Short Pad Tube.

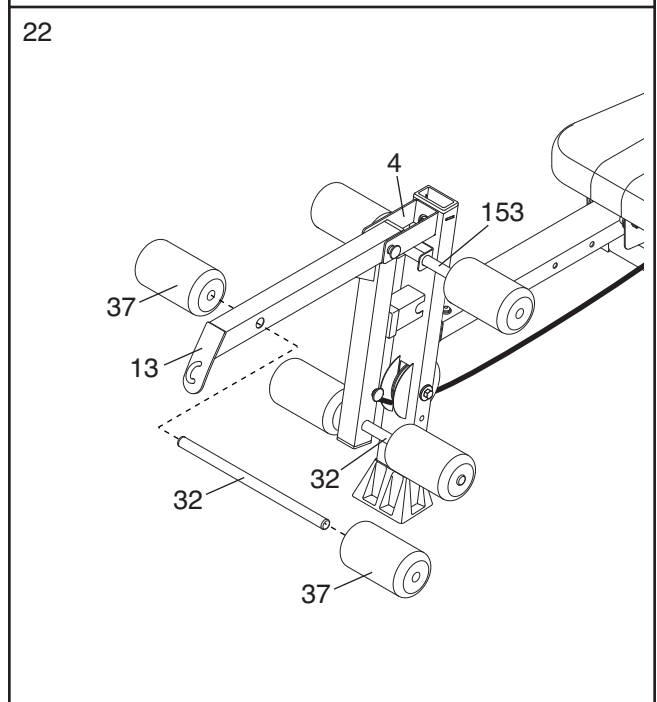

Repeat this step with the Long Pad Tube (153) and the Front Leg (4).

23. Attach the Backrest Cap (40) to the Backrest Frame (17) with two M4 x 16mm Self-tapping Screws (104).

Attach a Bumper (168) to the Backrest Frame (17) with an M4 x 16mm Self-tapping Screw (104) and an M4 Washer (157).

Attach the Right Pinch Guard (42) to the Backrest Frame (17) with two M4 x 9mm Self-tapping Screws (106). **Attach the Left Pinch Guard (41) in the same manner.**

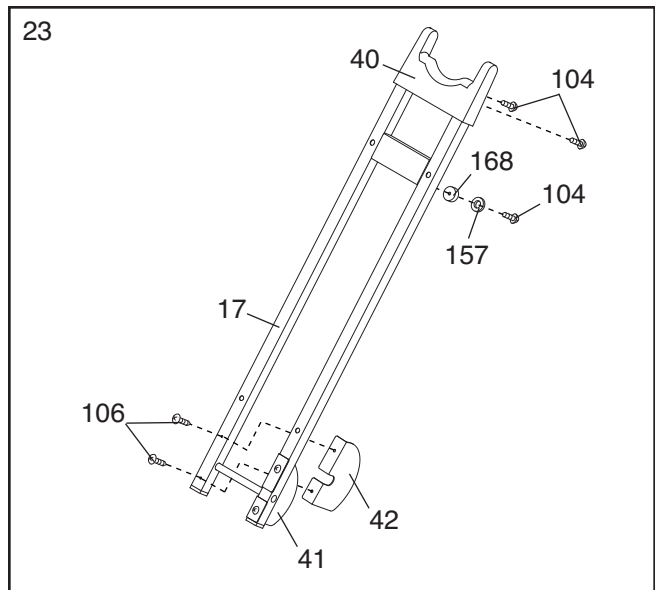

24. Attach the Backrest (24) to the Backrest Frame (17) with four M6 x 38mm Screws (128) and four M6 Washers (126).

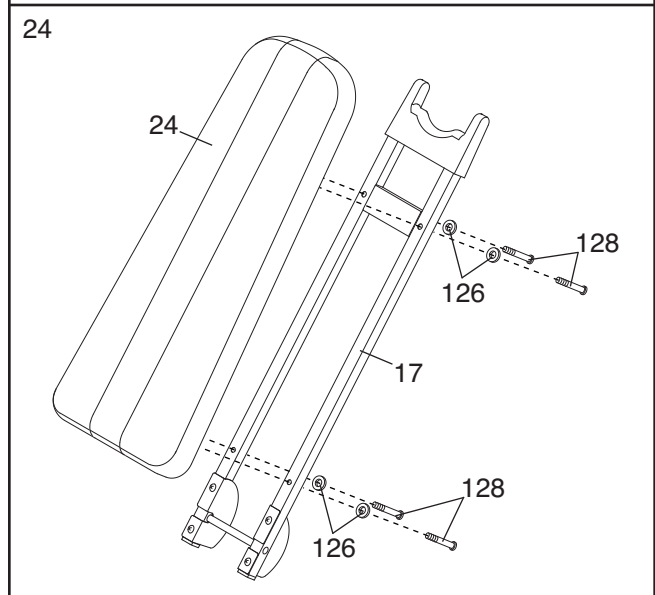

25. Insert the rod on the Backrest Frame (17) into the slot in the Seat Carriage (16). **Hold the Backrest Frame vertically over the Seat Carriage and slide the rod into the slot, as shown in the inset drawing.**

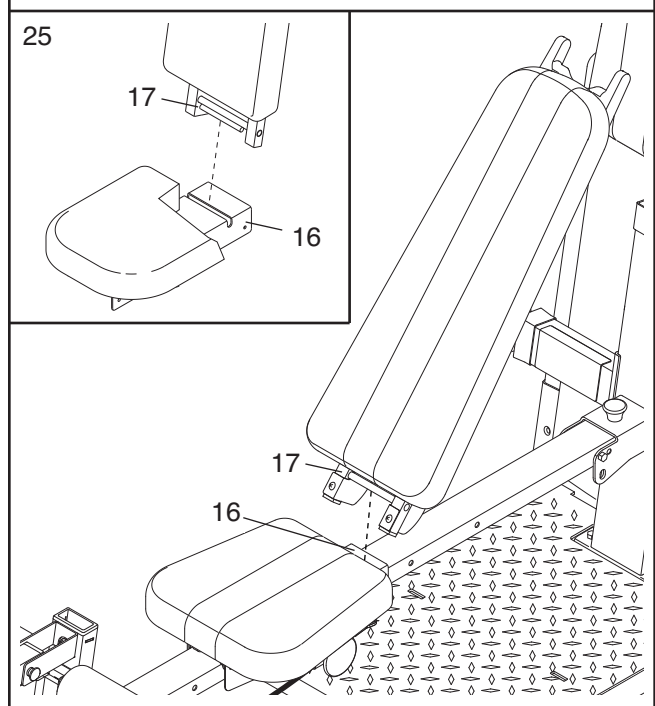

26. Attach the Curl Pad (26) to the Curl Post (12) with two M6 x 16mm Screws (108).

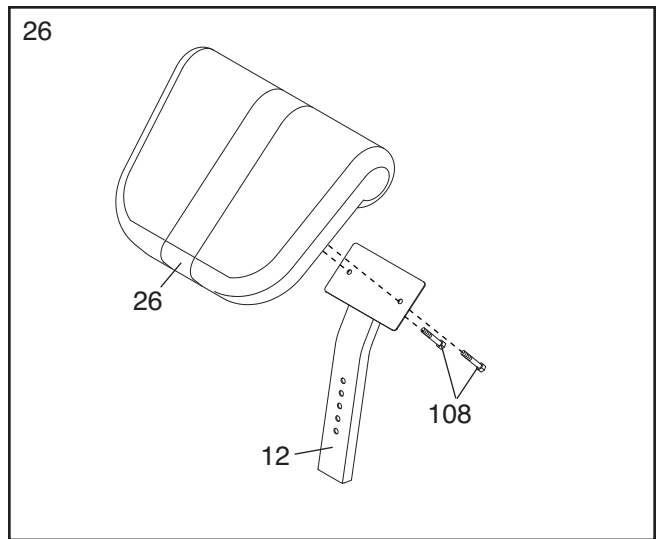

27. Make sure that all parts have been properly tightened. The use of the remaining parts will be explained in ADJUSTMENTS, beginning on the next page.

Before using the resistance system, turn on the console and change the resistance setting as described in CONSOLE OPERATION on page 20.

ADJUSTMENTS

This section explains how to adjust the resistance system. See the EXERCISE GUIDELINES on page 23 for important information about how to get the most benefit from your exercise program. Also, see the accompanying exercise guide to see the correct form for each exercise.

Make sure all parts are properly tightened each time the resistance system is used. Replace worn parts immediately. The resistance system can be cleaned with a damp cloth and a mild, non-abrasive detergent. Do not use solvents.

ATTACHING THE HIGH PULLEYS

To use a high pulley, slide the hook on the Pulley Housing (27) onto a hook on the Top Frame (20). Attach the end of the Short Cable (73) without the ball to the end of the Rope (70) with a Cable Clip (161). **Attach the other high pulley in the same manner.**

Remove the high pulleys when not in use.

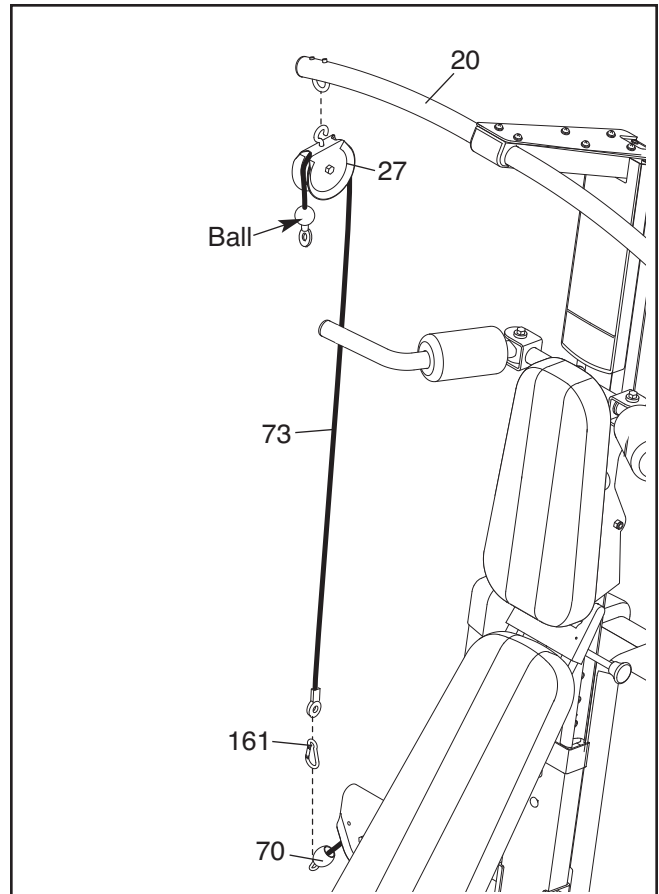

ATTACHING THE LEG LEVER

To use the Leg Lever (13), attach it to the Front Leg (4) with a Leg Lever Pin (91) and a Cotter Pin (90).

Attach the Split Cable (72) inside the Leg Lever (13) with a Leg Lever Pin (91) and a Cotter Pin (90).

See the inset drawing. Attach one of the long ends of the Split Cable (72) to one end of the Rope (70) with a Cable Clip (161). **Attach the other long end of the Split Cable to the other end of the Rope in the same manner.**

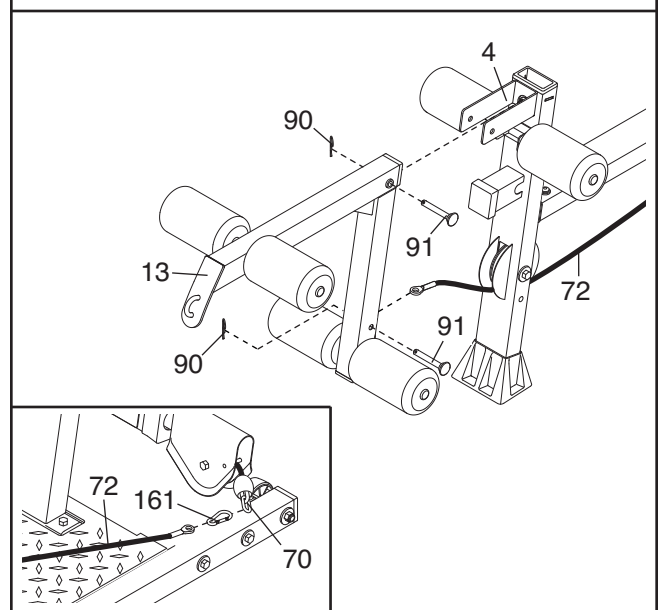

ATTACHING THE ACCESSORIES

To attach a Short Handle (84) to a high pulley, first attach the pulley housings to the resistance system (see ATTACHING THE HIGH PULLEYS on the previous page). Then, attach the Handle to a Short Cable (73) with a Cable Clip (161).

The Long Handles (not shown) and the Ankle Strap (not shown) can be attached to the Short Cables (73) or the Rope (not shown) with Cable Clips (161). Attach the Hip Strap (not shown) to the ends of the Rope with two Cable Clips.

The Ab Strap (not shown) can be attached to the Rope (not shown) using the two Extension Straps (not shown) and four Cable Clips (161).

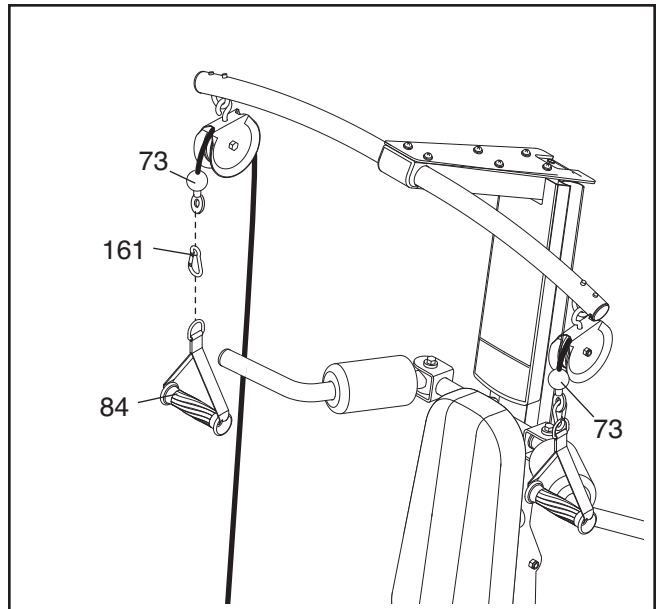

ATTACHING THE CURL PAD

To attach the Curl Pad (26), insert the Curl Post (12) into the Front Leg (4). Secure the Curl Post with the Curl Knob (45).

Remove the Curl Pad (26) from the resistance system when performing an exercise that does not require it.

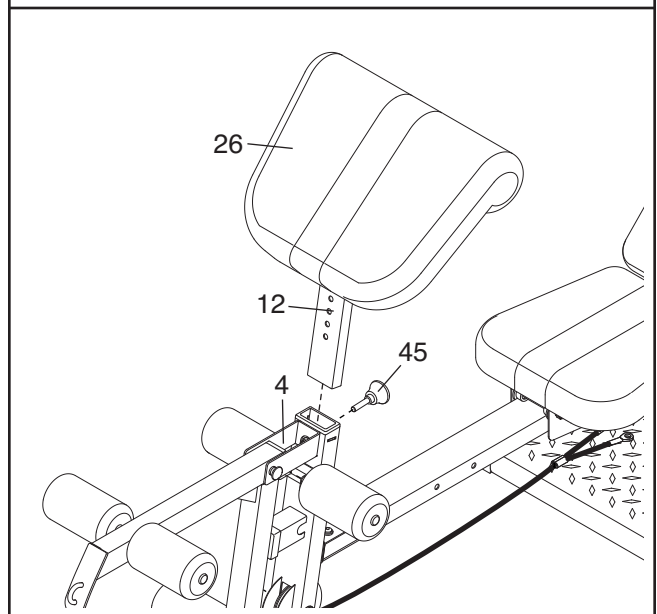

ATTACHING THE CURL BAR

To use the Curl Bar (43), first attach the leg lever to the front leg (see ATTACHING THE LEG LEVER on the previous page). Attach the Curl Bar to the hook on the Leg Lever (13).

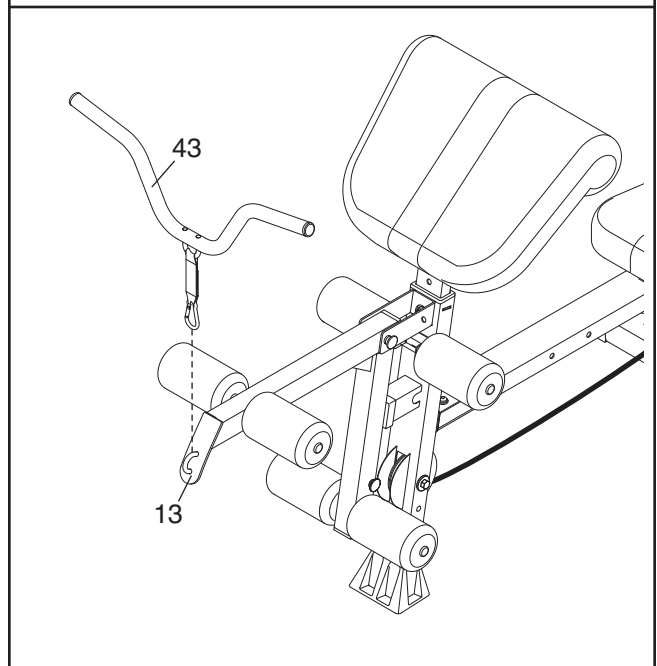

ADJUSTING THE SQUAT ARM

To adjust a Squat Arm (18), pull the Arm to the desired position.

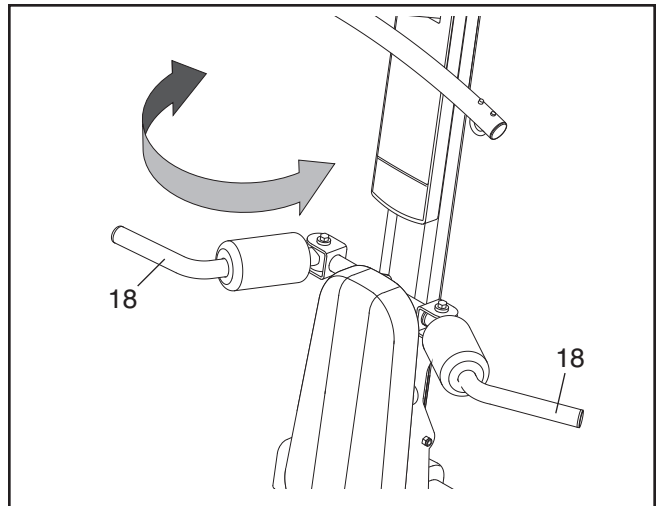

ATTACHING THE SQUAT STATION

To use the squat station, first remove the backrest (see ADJUSTING THE BACKREST below). Next, adjust the squat arm to the forward position (see ADJUSTING THE SQUAT ARM above). Then, insert a Squat Pin (35) into the correct hole in the Upright (3). Finally, attach each end of the Rope (70) to the Squat Carriage (10) with an Extension Strap (82) and two Cable Clips (161).

Note: The Squat Pin (35) will determine the lowest point to which the Squat Carriage (10) can descend. The Squat Carriage should not be able to descend so low that the user could become trapped under the Squat Arms (18).

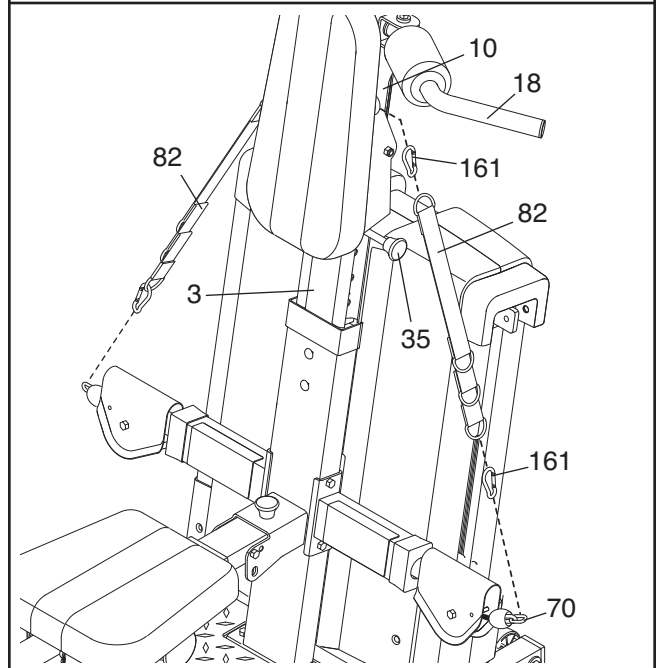

ADJUSTING THE BACKREST

The Backrest (24) can be used in a level position or an inclined position. To use the Backrest in a level position, secure the Seat Carriage (16) at the adjustment hole in the Rail (5) closest to the Front Leg (not shown) (see ADJUSTING THE SEAT on the next page).

To use the Backrest (24) in an inclined position, secure the Seat Carriage (16) at one of the other adjustment holes in the Rail (5). Rest the Backrest against the Upright Base (2) or the Upright (3). **Note: To use the Backrest in the most inclined position, the Squat Pin (not shown) must hold the Squat Carriage (not shown) in the highest position (see ATTACHING THE SQUAT STATION above).**

For row exercises, remove the Backrest Frame (17) from the Seat Carriage (16). Hold the Backrest Frame vertically over the Seat Carriage and lift the rod out of the slot (see the inset drawing).

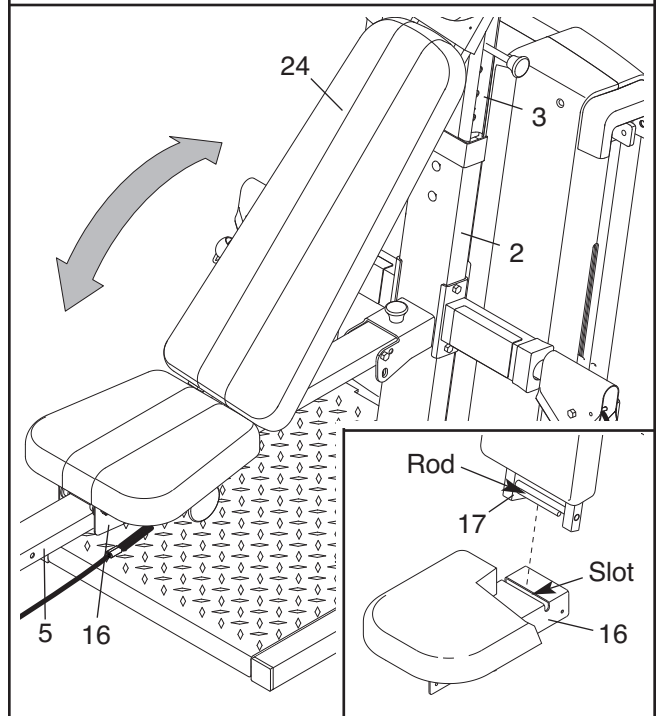

ADJUSTING THE SEAT

The Seat (25) can be secured at various positions on the Rail (5). To move the Seat, pull the Seat Knob (138) out as far as it will go and slide the Seat to the desired position. Engage the Seat Knob into an adjustment hole in the Rail.

To perform row exercises, the hip strap must be attached to the rope (see ATTACHING THE ACCESSORIES on page 17), and the Seat Carriage (16) must be able to roll along the Rail (5). First, remove the backrest from the seat carriage (see ADJUSTING THE BACKREST on page 18). Then, pull the Seat Knob (138) out as far as it will go, and turn the Seat Knob so that the pin rests at the end of the “L”-shaped slot (see the inset drawing).

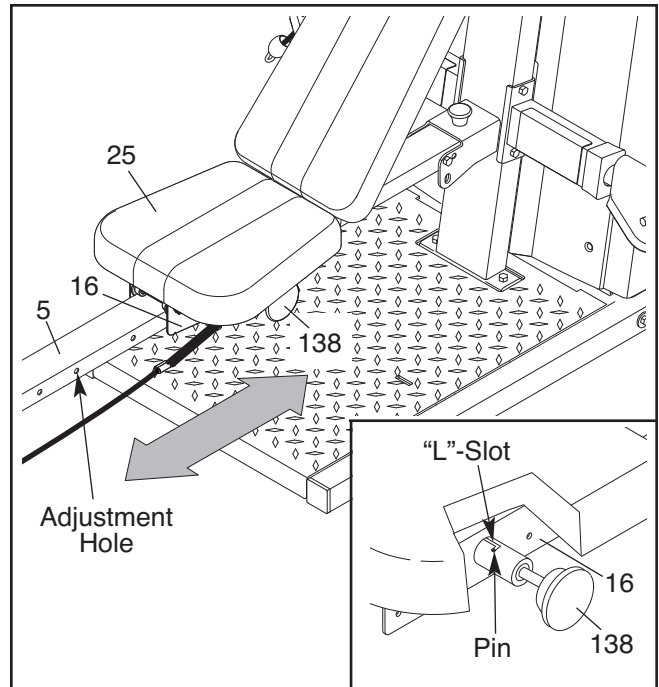

STORING THE RESISTANCE SYSTEM

To store the resistance system, first remove the Curl Pad (not shown) and the Leg Lever (not shown) from the resistance system. Secure the Seat (25) at the position closest to the Front Leg (4) (see ADJUSTING THE SEAT above). Next, remove the Storage Knob (44) from the Upright Base (2). Lift the Front Leg toward the Top Frame (20). Tighten the Storage Knob into the side of the Upright Base and into the Rail (5).

To move the resistance system, stand behind the Upright (3) and place the toe of your shoe on the end of the Base (1). Tilt the resistance system back onto the Wheels (49) and roll it to the new location.

⚠ WARNING: Make sure that the Storage Knob (44) is in place and fully tightened each time the resistance system is used.

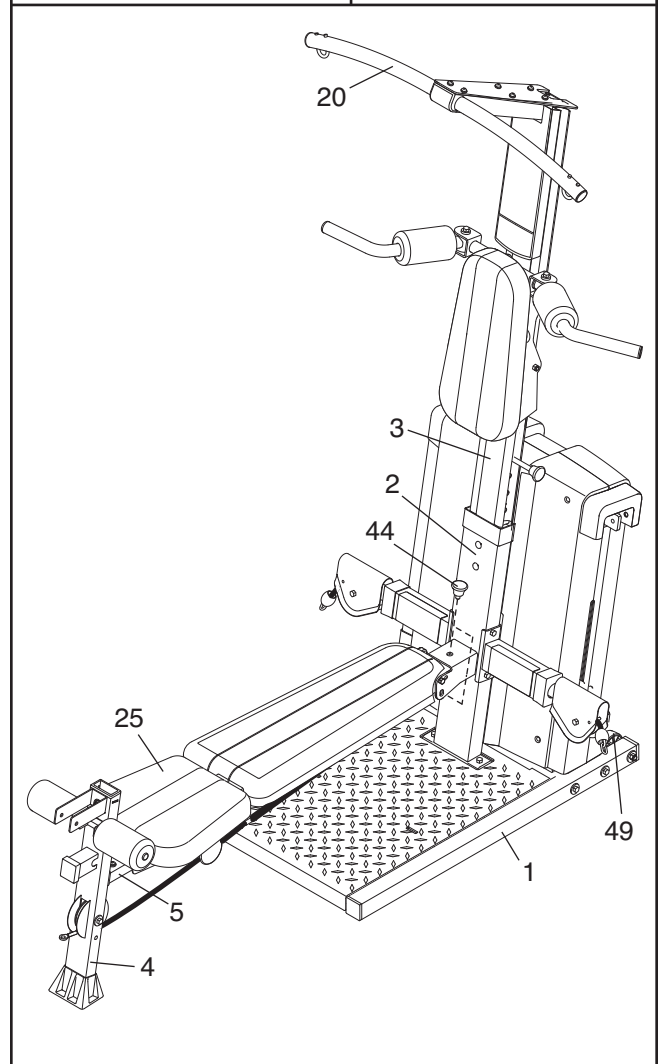

CONSOLE OPERATION

FEATURES OF THE CONSOLE

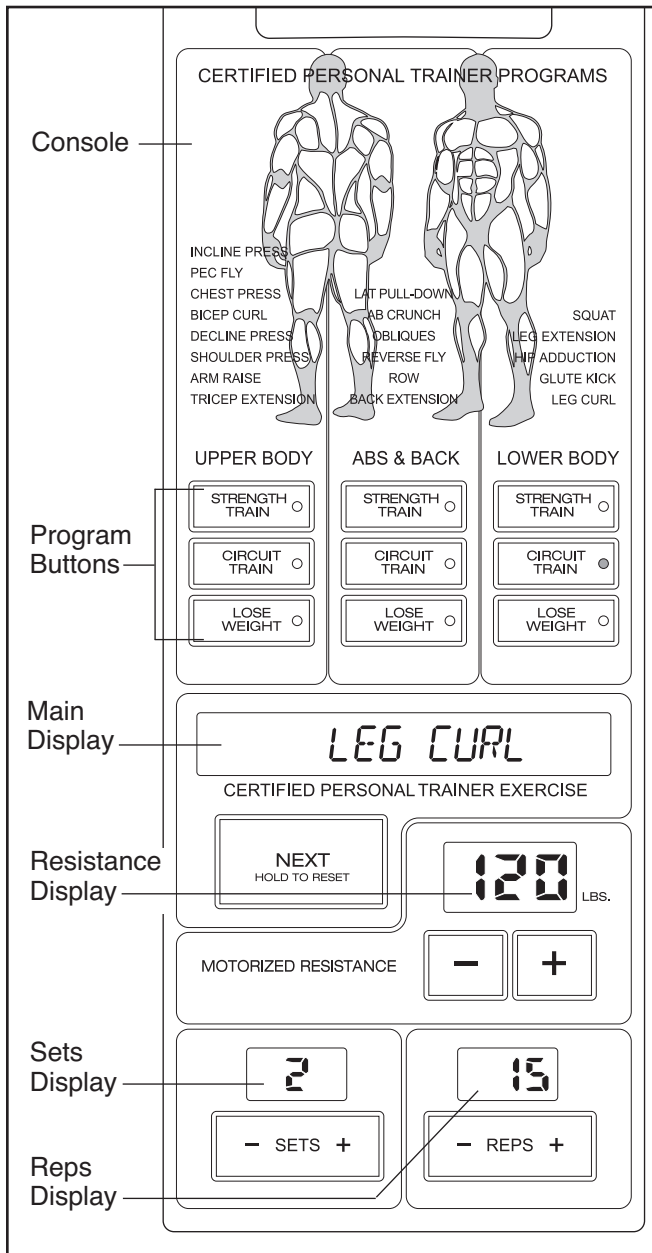

The heart of the resistance system is the digital resistance training console. The console offers both a manual mode and nine workout programs. When the manual mode is selected, the resistance setting can be changed with the touch of a button. When a program is selected, the console will guide you through an effective upper body, ab and back, or lower body workout.

To use the manual mode of the console, follow the steps at the right. To use a program, see page 21.

PLUGGING IN THE RESISTANCE SYSTEM

Plug the indicated end of the Transformer (181) into the Rear Mech Cover (14). Plug the other end of the Transformer into a 120-volt outlet. All indicators and displays on the console will flash once; the console will then be ready for use. The motor may be heard while the resistance system calibrates itself. **Important: Always plug in the transformer when using the resistance system.**

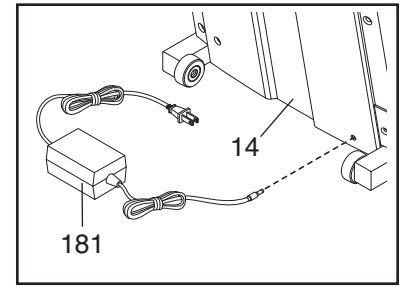

MANUAL OPERATION

1. Plug in the transformer.

Plug the transformer into a 120-volt outlet (see PLUGGING IN THE RESISTANCE SYSTEM above). **Important: Always plug in the transformer when using the resistance system.**

Note: When the power is on, the words MANUAL MODE will appear in the main display. To use a program, see PROGRAM OPERATION on page 21. If you want to return to the manual mode while the console is running a program, press and hold the NEXT button.

If no buttons are pressed and no cables are pulled for ten minutes, the console will go to sleep. Press any button to resume exercising.

2. Select a resistance setting.

The current resistance setting will appear in the resistance display. To select a different resistance setting, first **make sure that no cables are being pulled**. Next, press the resistance + or - buttons. Each time a button is pressed, the resistance setting will increase or decrease by 1 pound. To change the resistance setting quickly, hold down one of the buttons.

Note: While the resistance setting is changing, the motor will be heard. **To prevent damage to the motor, do not pull any of the cables while the resistance setting is changing.** If a cable is pulled, the words RELEASE HANDLES AND READJUST RESISTANCE AS DESIRED may appear in the main display.

3. Enter the numbers of sets and repetitions that you plan to complete for an exercise.

To enter the number of sets that you plan to do, press the SETS + or – buttons. To enter the number of repetitions that you plan to do, press the REPS + or – buttons.

Note: If you do not enter the numbers of sets and repetitions that you plan to do, the console will count the total number of repetitions that you complete during your workout.

4. Perform the exercise.

If you have entered numbers of sets and repetitions, the console will count down the repetitions and sets you have completed. When you complete the exercise, repeat steps 2 and 3 above for the next exercises.

5. Unplug the transformer.

When you complete your workout, unplug the transformer from the 120-volt outlet.

PROGRAM OPERATION

1. Plug in the transformer.

Plug the transformer into a 120-volt outlet (see PLUGGING IN THE RESISTANCE SYSTEM on page 20). **Important: Always plug in the transformer when using the resistance system.**

Note: If no buttons are pressed and no cables are pulled for ten minutes, the console will go to sleep. Press any button to resume exercising.

2. Select a program.

When the power is on, the words MANUAL MODE will appear in the main display. To select a program, press one of the nine program buttons. The indicator on the button you press will light.

Note: The console offers three upper body programs, three ab and back programs, and three lower body programs. If you wish to exercise your upper body and if your goal is to lose weight, for example, press the LOSE WEIGHT button below the words UPPER BODY.

3. Row for five minutes to warm up.

When a program is selected, the words CARDIO ROW will appear in the main display. To warm up,

perform the cardio row exercise while the main display counts down from 5 minutes.

Note: To see the correct form for the cardio row exercise, see the included exercise guide. If the resistance setting is too high or too low, select a different resistance setting by pressing the resistance + or – buttons.

4. Adjust the resistance setting and the numbers of sets and repetitions for the exercise if desired.

The name of an exercise in the program will appear in the main display. The recommended resistance setting and the recommended numbers of sets and repetitions for the exercise will appear in the three displays below the main display.

The recommended resistance setting and the recommended numbers of sets and repetitions may be too high or too low for you, depending on such factors as your body size and your physical condition. If desired, adjust the resistance setting and the numbers of sets and repetitions by pressing the + or – buttons below each display.

5. Perform the exercise.

As you perform the exercise, the console will count down the numbers of sets and repetitions you have completed.

When you complete the exercise, the word RESTING will appear in the main display. It is recommended that you rest while the main display counts down.

6. Perform the remaining exercises in the program.

After you have completed an exercise in the program, press the NEXT button and the name of the next exercise will appear in the main display. Repeat steps 4 and 5 above for the exercise.

Note: The program may include the same exercise twice, with different resistance settings and different numbers of sets and repetitions. If you wish to skip any part of the program, press the NEXT button to advance to the next part of the program.

When you complete the program, the words WORKOUT COMPLETE will appear in the main display.

7. Unplug the transformer.

When you complete your workout, unplug the transformer from the 120-volt outlet.

TROUBLESHOOTING

RECALIBRATING THE CONSOLE

To recalibrate the Console (21), first plug in the resistance system (see PLUGGING IN THE RESISTANCE SYSTEM on page 20). Then, press and hold the NEXT button and the MOTORIZED WEIGHT ADJUSTMENT + button for five seconds. When the buttons are released, a number will appear in the REPS display. Press the NEXT button again, and then press the MOTORIZED WEIGHT ADJUSTMENT + button; this will start the recalibration process. This may take a few seconds as the motor moves between the lowest and highest resistance settings. When the motor finishes, unplug the transformer from the 120-volt outlet.

The Console (21) will be recalibrated. Use the resistance system as described in the CONSOLE OPERATION section, starting on page 20.

TIGHTENING THE ROPE

The type of rope used on the resistance system can stretch slightly when it is first used. If there is slack in the rope before resistance is felt, the rope should be tightened.

To tighten the Rope (70), first set the system resistance level to 100 pounds. Locate the end of the Rope with the Rope Clamps (165, 166) and pull it out until the Rope is tight. Then, measure the distance between the Rope Cover (169) and the Swivel Arm (29).

Set the system resistance to the lowest level. Have a second person pull the Rope (70) out and hold it while the Rope is adjusted. Push the Rope Cover (169) down the Rope and loosen the two M5 x 16mm Button Screws (164). Pull the Rope through the Link (167) and the Rope Clamps (165, 166) to shorten the Rope by the measured amount. Then, retighten the two Screws and cover the Rope Clamps with the Rope Cover. **Note: There should be 1/2" between the Link and the Rope Clamps.**

⚠ WARNING: Always make sure the two M5 x 16mm Button Screws (164) are fully tightened before the resistance system is used.

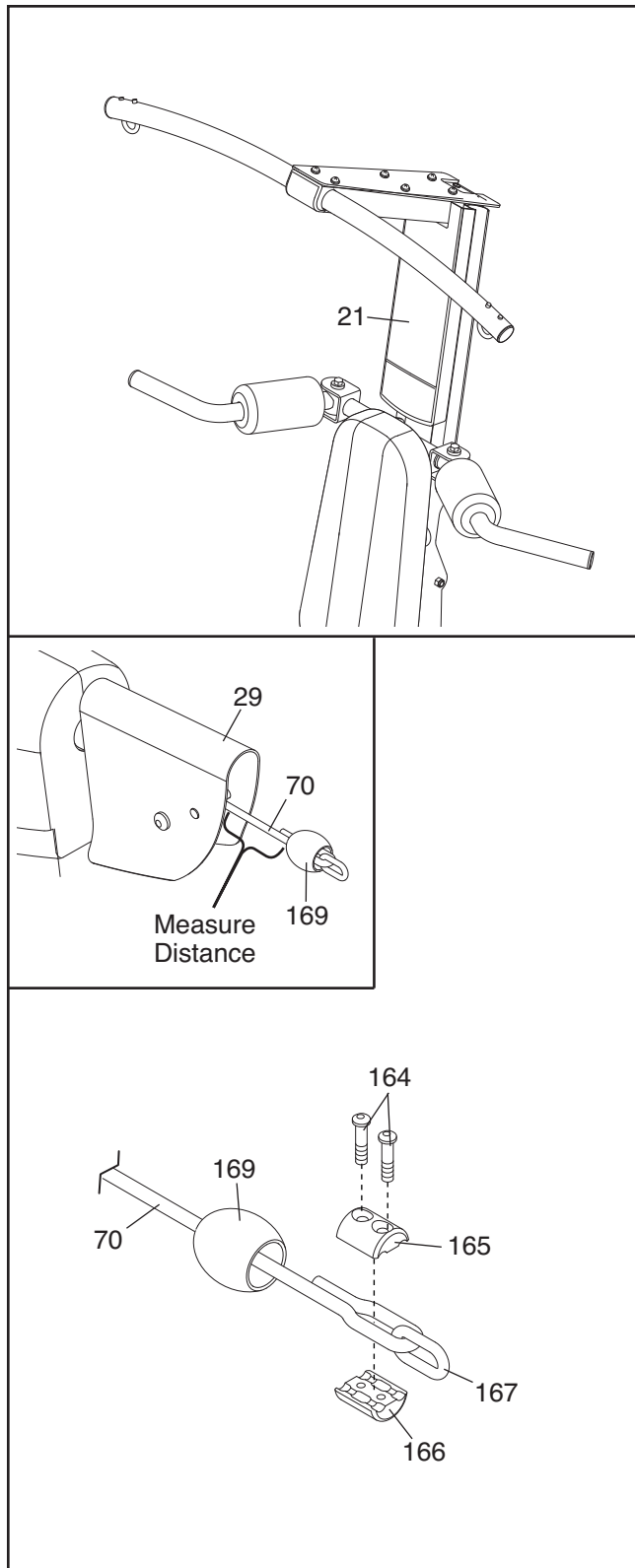

EXERCISE GUIDELINES

THE FOUR BASIC TYPES OF WORKOUTS

Muscle Building

To increase the size and strength of your muscles, push them close to their maximum capacity. Your muscles will continually adapt and grow as you progressively increase the intensity of your exercise. You can adjust the intensity level of an individual exercise in two ways:

- by changing the amount of resistance used
- by changing the number of repetitions or sets performed. (A “repetition” is one complete cycle of an exercise, such as one sit-up. A “set” is a series of repetitions.)

The proper amount of resistance for each exercise depends upon the individual user. You must gauge your limits and select the amount of resistance that is right for you. Begin with 3 sets of 8 repetitions for each exercise you perform. Rest for 3 minutes after each set. When you can complete 3 sets of 12 repetitions without difficulty, increase the amount of resistance.

Toning

You can tone your muscles by pushing them to a moderate percentage of their capacity. Select a moderate amount of resistance and increase the number of repetitions in each set. Complete as many sets of 15 to 20 repetitions as possible without discomfort. Rest for 1 minute after each set. Work your muscles by completing more sets rather than by using high amounts of resistance.

Weight Loss

To lose weight, use a low amount of resistance and increase the number of repetitions in each set. Exercise for 20 to 30 minutes, resting for a maximum of 30 seconds between sets.

Cross Training

Cross training is an efficient way to get a complete and well-balanced fitness program. An example of a balanced program is:

- Plan strength training workouts on Monday, Wednesday, and Friday.
- Plan 20 to 30 minutes of aerobic exercise, such as running on a treadmill or riding on an elliptical or exercise bike, on Tuesday and Thursday.
- Rest from both strength training and aerobic exercise for at least one full day each week to give your body time to regenerate.

The combination of strength training and aerobic exercise will reshape and strengthen your body, plus develop your heart and lungs.

PERSONALIZING YOUR EXERCISE PROGRAM

Determining the exact length of time for each workout, as well as the number of repetitions or sets completed, is an individual matter. It is important to avoid overdoing it during the first few months of your exercise program. You should progress at your own pace and be sensitive to your body’s signals. If you experience pain or dizziness at any time while exercising, stop immediately and begin cooling down. Find out what is wrong before continuing. Remember that adequate rest and a proper diet are important factors in any exercise program.

WARMING UP

Begin each workout with 5 to 10 minutes of stretching and light exercise to warm up. Warming up prepares your body for more strenuous exercise by increasing circulation, raising your body temperature and delivering more oxygen to your muscles.

WORKING OUT

Each workout should include 6 to 10 different exercises. Select exercises for every major muscle group, emphasizing areas that you want to develop most. To give balance and variety to your workouts, vary the exercises from session to session.

Schedule your workouts for the time of day when your energy level is the highest. Each workout should be followed by at least one day of rest. Once you find the schedule that is right for you, stick with it.

EXERCISE FORM

Maintaining proper form is an essential part of an effective exercise program. This requires moving through the full range of motion for each exercise, and moving only the appropriate parts of the body. Exercising in an uncontrolled manner will leave you feeling exhausted. On the exercise guide accompanying this manual you will find photographs showing the correct form for several exercises, and a list of the muscles affected. Refer to the muscle chart on the next page to find the names of the muscles.

The repetitions in each set should be performed smoothly and without pausing. The exertion stage of each repetition should last about half as long as the return stage. Proper breathing is important. Exhale during the exertion stage of each repetition and inhale during the return stroke. Never hold your breath.

Rest for a short period of time after each set. The ideal resting periods are:

- Rest for three minutes after each set for a muscle building workout.
- Rest for one minute after each set for a toning workout.
- Rest for 30 seconds after each set for a weight loss workout.

Plan to spend the first couple of weeks familiarizing yourself with the equipment and learning the proper form for each exercise.

COOLING DOWN

End each workout with 5 to 10 minutes of stretching. Include stretches for both your arms and legs. Move

slowly as you stretch and do not bounce. Ease into each stretch gradually and go only as far as you can without strain. Stretching at the end of each workout is an effective way to increase flexibility.

STAYING MOTIVATED

For motivation, keep a record of each workout. The chart on pages 25 and 26 of this manual can be photocopied and used to schedule and record your workouts. List the date, the exercises performed, the resistance used, and the numbers of sets and repetitions completed. Record your weight and key body measurements at the end of every month. Remember, the key to achieving the greatest results is to make exercise a regular and enjoyable part of your everyday life.

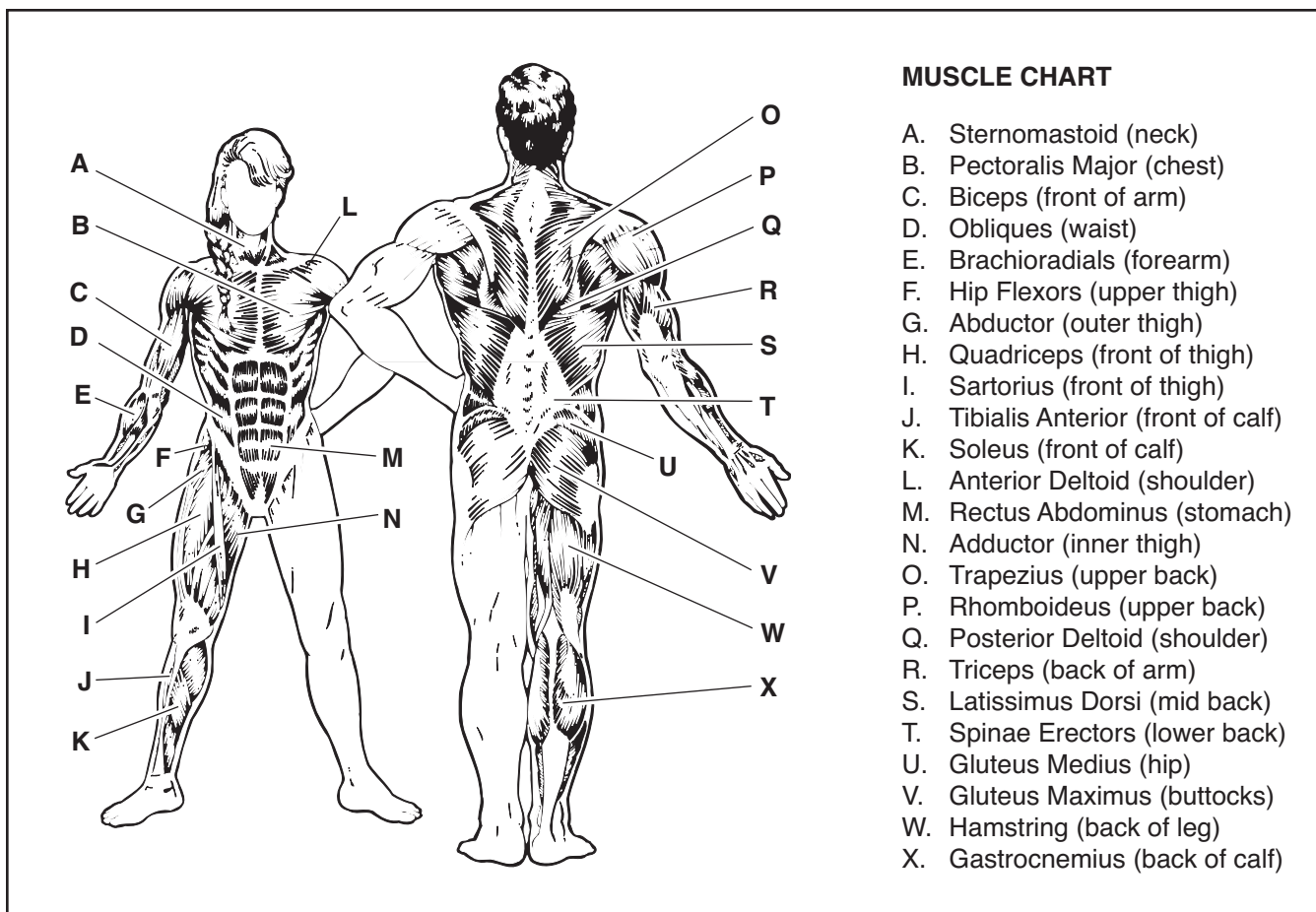

MONDAY	EXERCISE	WEIGHT	SETS	REPS
Date: _____ / _____ / _____				

TUESDAY AEROBIC EXERCISE

Date: _____ / _____ / _____

WEDNESDAY	EXERCISE	WEIGHT	SETS	REPS
Date: _____ / _____ / _____				

THURSDAY AEROBIC EXERCISE

Date: _____ / _____ / _____

FRIDAY	EXERCISE	WEIGHT	SETS	REPS
Date: _____ / _____ / _____				

Make photocopies of this page for scheduling and recording your workouts.

MONDAY	EXERCISE	WEIGHT	SETS	REPS
Date: _____ / _____ / _____				

TUESDAY AEROBIC EXERCISE

Date: _____ / _____ / _____

WEDNESDAY	EXERCISE	WEIGHT	SETS	REPS
Date: _____ / _____ / _____				

THURSDAY AEROBIC EXERCISE

Date: _____ / _____ / _____

FRIDAY	EXERCISE	WEIGHT	SETS	REPS
Date: _____ / _____ / _____				

Make photocopies of this page for scheduling and recording your workouts.

NOTES

PART IDENTIFICATION CHART – Model No. WESY7974.0

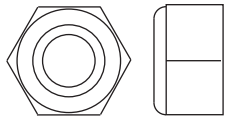

M10 Nylon Locknut (112)



M8 Nylon Jamnut (139)

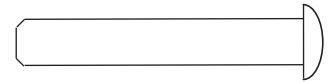

M6 x 38mm Screw (128)

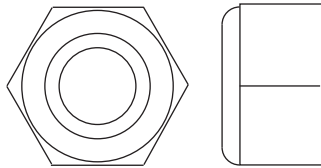

M14 Nylon Locknut (127)

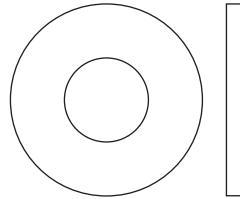

M10 Washer (129)



M10 x 53mm Button Bolt (140)

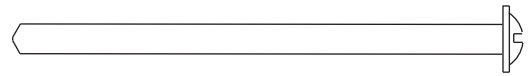

M4 x 65mm Self-tapping Screw (158)

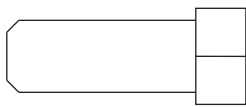

M10 x 25mm Screw (105)

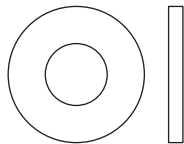

M8 Washer (152)

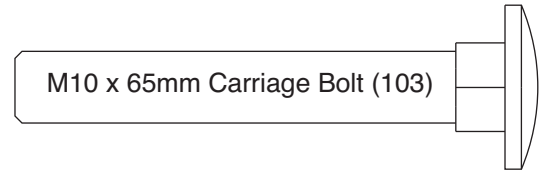

M10 x 65mm Carriage Bolt (103)

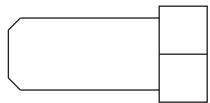

M10 x 20mm Screw (113)

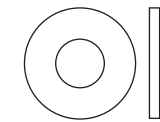

M6 Washer (126)



M10 x 65mm Button Screw (117)

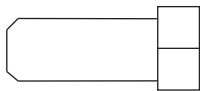

M8 x 20mm Screw (95)



M4 Washer (157)

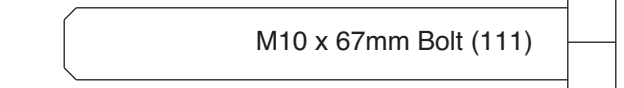

M10 x 67mm Bolt (111)



M6 x 16mm Screw (108)

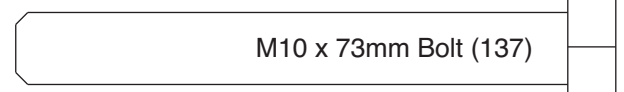

M10 x 73mm Bolt (137)



M5 x 16mm Button Screw (164)



M4 x 5mm Self-tapping Screw (176)

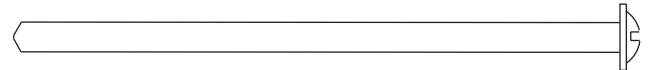

M4 x 80mm Self-tapping Screw (145)

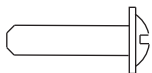

M4 x 16mm Self-tapping Screw (104)

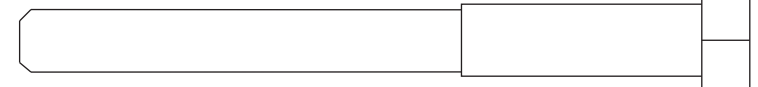

M8 x 90mm Shoulder Bolt (125)

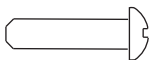

M4 x 16mm White ZP Self-tapping Screw (159)

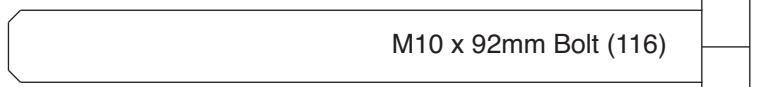

M10 x 92mm Bolt (116)

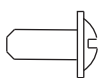

M4 x 9mm Self-tapping Screw (106)

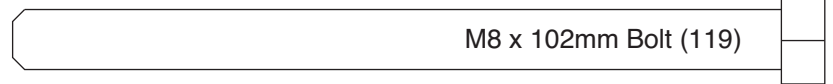

M8 x 102mm Bolt (119)

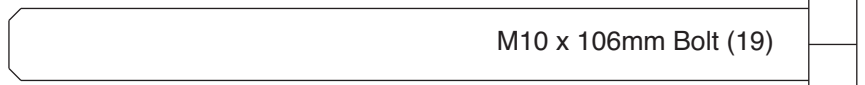

M10 x 106mm Bolt (19)

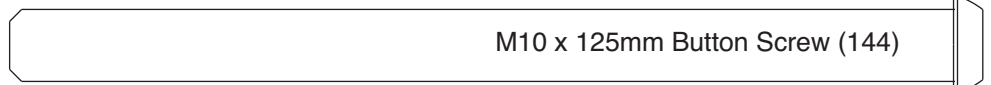

M10 x 125mm Button Screw (144)

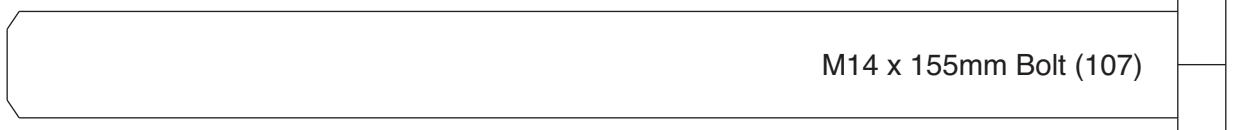

M14 x 155mm Bolt (107)

PART LIST—Model No. WESY7974.0

R1005A

Key No.	Qty.	Description	Key No.	Qty.	Description
1	1	Base	54	1	Max Pack Frame
2	1	Upright Base	55	1	Motor Assembly
3	1	Upright	56	2	Mech Arm Plate
4	1	Front Leg	57	1	Lower Pulley Plate
5	1	Rail	58	2	M12 Washer
6	1	Right Squat Rail	59	1	Backing Plate
7	1	Left Squat Rail	60	1	Rep Counter
8	1	Left Arm Frame	61	4	Band Wheel
9	1	Base Plate	62	2	Rod
10	1	Squat Carriage	63	2	Steel Washer
11	6	M4 x 12mm Screw	64	2	Limit Switch
12	1	Curl Post	65	2	38mm Round Inner Cap
13	1	Leg Lever	66	2	25mm Round Inner Cap
14	1	Rear Mech Cover	67	2	Foam Grip
15	1	Front Mech Cover	68	2	32mm Round Inner Cap
16	1	Seat Carriage	69	4	Arm Bushing
17	1	Backrest Frame	70	1	Rope
18	2	Squat Arm	71	4	Plastic Base Foot
19	1	M10 x 106mm Bolt	72	1	Split Cable
20	1	Top Frame	73	2	Short Cable
21	1	Console	74	6	Seat Wheel
22	4	Gas Spring End	75	1	45mm Square Outer Cap
23	1	Upright Plate	76	1	M10 x 95mm Button Bolt
24	1	Backrest	77	2	Gas Spring
25	1	Seat	78	3	Cable Trap
26	1	Curl Pad	79	1	Small Cable Trap
27	2	Pulley Housing	80	4	16mm Spacer
28	1	Squat Backrest	81	1	Side Mech Cover
29	2	Swivel Arm	82	2	Extension Strap
30	2	50mm x 75mm Plastic Spacer	83	1	Ankle Strap
31	1	Front Cover	84	2	Short Handle
32	2	Short Pad Tube	85	2	Long Handle
33	6	Wire Harness	86	1	Ab Strap
34	2	Grip Tape	87	1	Hip Strap
35	1	Squat Pin	88	14	90mm Thin Pulley
36	2	Small Foam Pad	89	1	M12 x 45mm Bolt
37	6	Large Foam Pad	90	2	Cotter Pin
38	1	Front Leg Foot	91	2	Leg Lever Pin
39	1	Bushing	92	3	90mm Pulley
40	1	Backrest Cap	93	2	"V"-pulley
41	1	Left Pinch Guard	94	4	50mm Square Inner Cap
42	1	Right Pinch Guard	95	4	M8 x 20mm Screw
43	1	Curl Bar	96	1	Clip
44	1	Storage Knob	97	2	M10 x 25mm Button Bolt
45	1	Curl Knob	98	2	M6 x 12mm Screw
46	1	Plastic Cap	99	2	M10 x 15mm Button Bolt
47	2	M12 x 72mm Bolt	100	2	5mm Spacer
48	6	19mm Round Inner Cap	101	1	M10 x 95mm Bolt
49	2	Wheel	102	3	M10 x 35mm Bolt
50	1	Lat Bar	103	4	M10 x 65mm Carriage Bolt
51	4	Squat Carriage Wheel	104	16	M4 x 16mm Self-tapping Screw
52	1	Mech Arm	105	2	M10 x 25mm Screw
53	1	Mech Link Arm	106	13	M4 x 9mm Self-tapping Screw

Key No.	Qty.	Description	Key No.	Qty.	Description
107	2	M14 x 155mm Bolt	149	1	50mm x 75mm Square Inner Cap
108	10	M6 x 16mm Screw	150	1	45mm Rhombus Inner Cap
109	1	M5 x 35mm Bolt	151	1	45mm Square Inner Cap
110	4	24mm Plastic Washer	152	8	M8 Washer
111	2	M10 x 67mm Bolt	153	1	Long Pad Tube
112	28	M10 Nylon Locknut	154	1	Rail Cap
113	2	M10 x 20mm Screw	155	2	25mm Square Inner Cap
114	4	17mm Spacer	156	4	M4 x 37mm Self-tapping Screw
115	2	32mm Thick Round Inner Cap	157	13	M4 Washer
116	3	M10 x 92mm Bolt	158	2	M4 x 65mm Self-tapping Screw
117	2	M10 x 65mm Button Screw	159	12	M4 x 16mm White ZP Self-tapping Screw
118	1	M12 Nut			
119	3	M8 x 102mm Bolt	160	4	M6 Nylon Locknut
120	2	M10 Lock Washer	161	4	Cable Clip
121	2	M6 Washer	162	4	M3 Nut
122	3	59mm Spacer	163	4	M10 Nylon Jamnut
123	6	8mm Spacer	164	2	M5 x 16mm Button Screw
124	1	Mech Frame	165	1	Top Rope Clamp
125	2	M8 x 90mm Shoulder Bolt	166	1	Bottom Rope Clamp
126	4	M6 Washer	167	1	Link
127	2	M14 Nylon Locknut	168	1	Bumper
128	4	M6 x 38mm Screw	169	2	Rope Cover
129	11	M10 Washer	170	2	Spring
130	2	25mm Spacer	171	1	Right Arm Frame
131	2	6mm Spacer	172	1	Upper Wire Harness
132	1	Copper Unit	173	1	Lower Wire Harness
133	4	M3 x 20mm Screw	174	1	73mm Spacer
134	1	70mm Pulley	175	4	M3 Lock Washer
135	2	Plastic Cap	176	2	M4 x 5mm Self-tapping Screw
136	2	M6 x 16mm Bolt	177	1	M5 Washer
137	6	M10 x 73mm Bolt	178	1	Inductor
138	1	Seat Knob	179	1	M5 Nylon Locknut
139	5	M8 Nylon Jamnut	180	1	76mm Spacer
140	2	M10 x 53mm Button Bolt	181	1	Transformer
141	6	M10 x 42mm Button Bolt	182	1	M10 x 92mm Grade 8 Bolt
142	1	M10 x 46mm Bolt	183	1	Cover Plate
143	1	M10 x 109mm Bolt	184	0	not used
144	1	M10 x 125mm Button Screw	#	1	User's Manual
145	2	M4 x 80mm Self-tapping Screw	#	1	Exercise Guide
146	2	M6 x 90mm Bolt	#	2	Hex Key
147	1	77mm Spacer	#	2	Grease Pack
148	2	4mm Spacer			

Note: “#” indicates a non-illustrated part. Specifications are subject to change without notice. See the back cover of the user’s manual for information about ordering replacement parts.

EXPLODED DRAWING A—Model No. WESY7974.0

R1005A

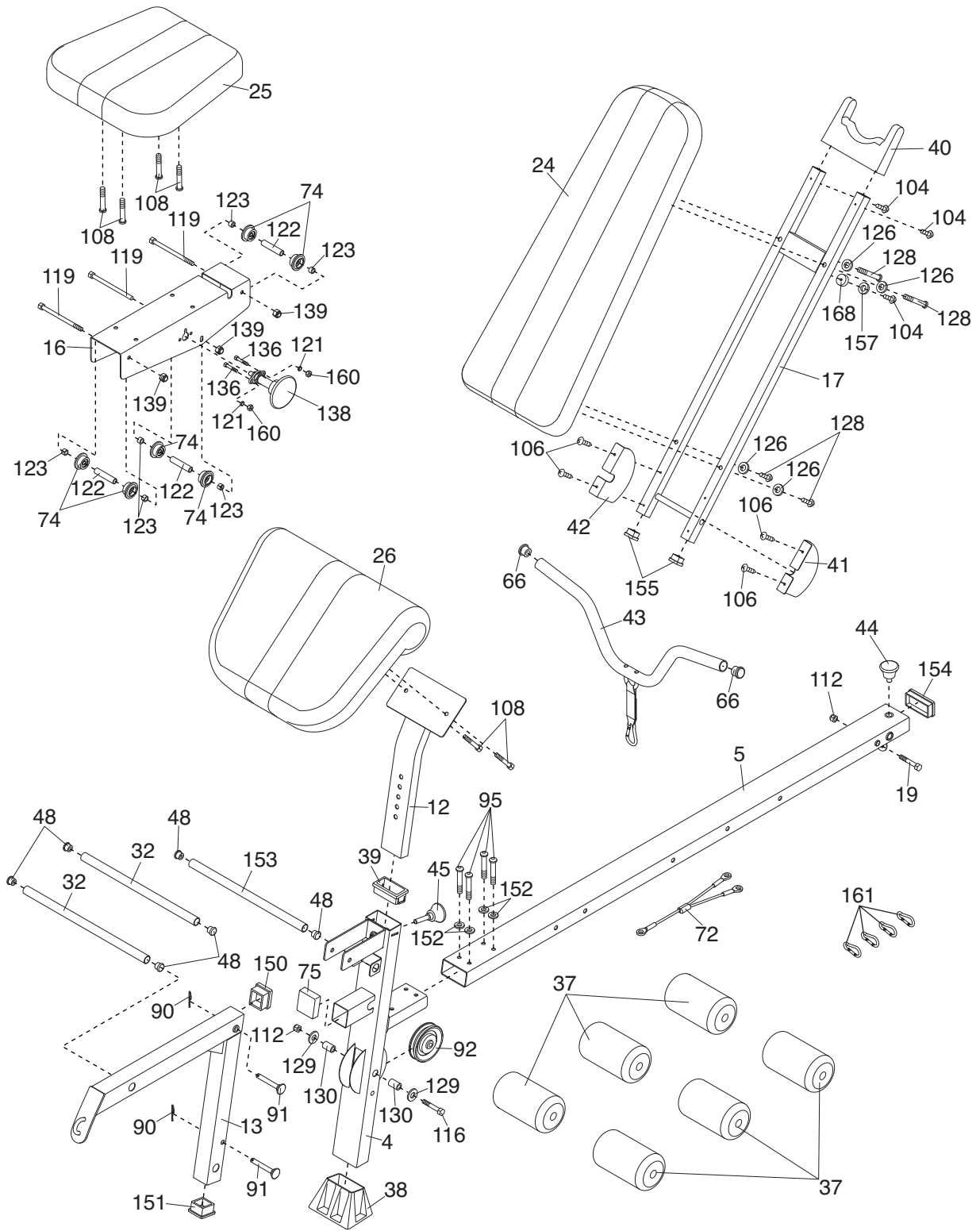

EXPLODED DRAWING C—Model No. WESY7974.0

R1005A

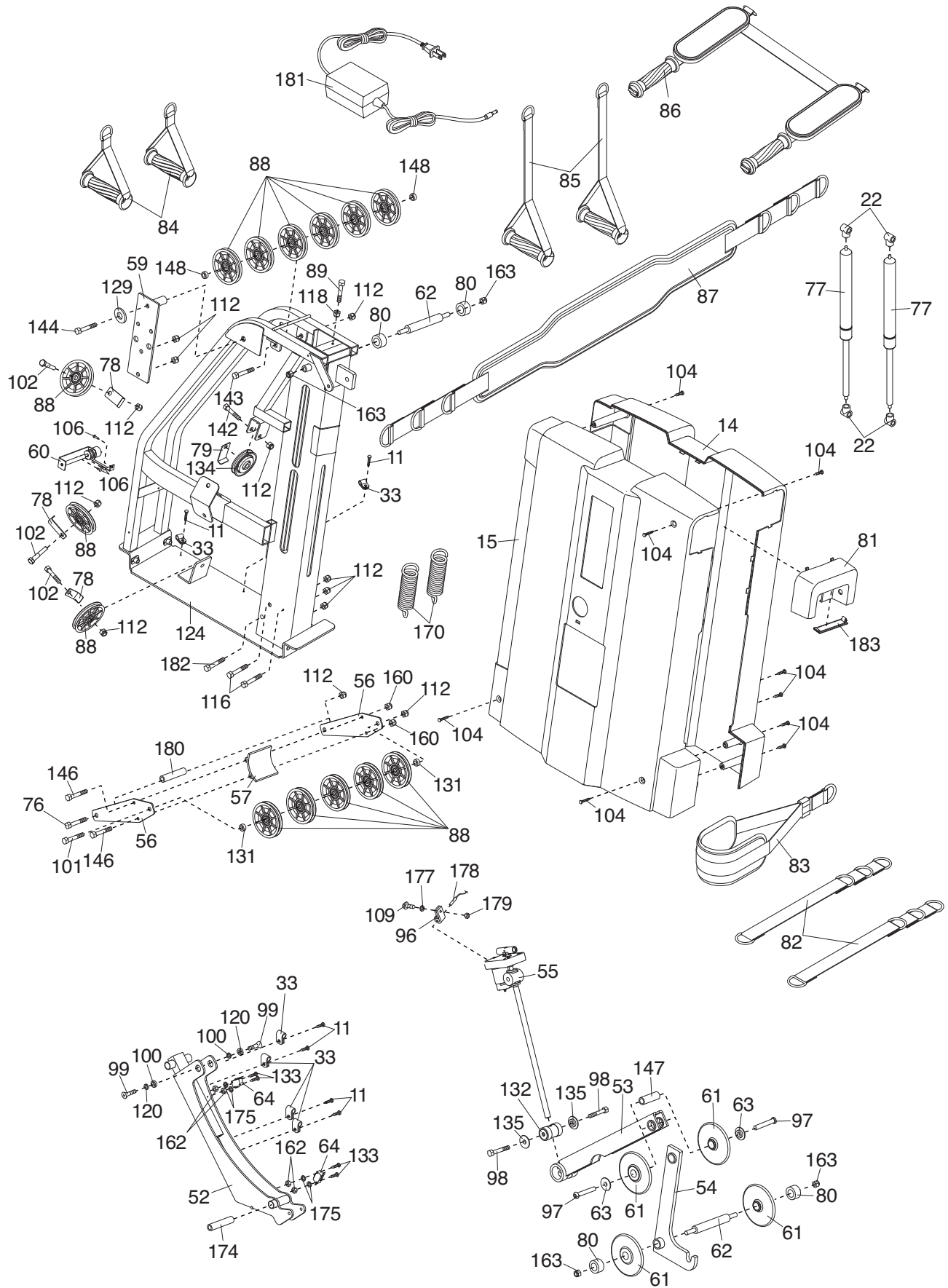

ORDERING REPLACEMENT PARTS

To order replacement parts, see the front cover of this manual. To help us assist you, please be prepared to give the following information:

- the MODEL NUMBER of the product (WESY7974.0)
- the NAME of the product (PLATINUM PLUS BY WEIDER resistance system)
- the SERIAL NUMBER of the product (see the front cover of this manual)
- the KEY NUMBER and DESCRIPTION of the part(s) (see the PART LIST and EXPLODED DRAWING in the center of this manual)

LIMITED WARRANTY

ICON Health & Fitness, Inc. (ICON), warrants this product to be free from defects in workmanship and material, under normal use and service conditions, for a period of ten (10) years from the date of purchase. This warranty extends only to the original purchaser. ICON's obligation under this warranty is limited to replacing or repairing, at ICON's option, the product through one of its authorized service centers. All repairs for which warranty claims are made must be pre-authorized by ICON. If the product is shipped to a service center, freight charges to and from the service center will be the customer's responsibility. For in-home service, the customer will be responsible for a minimal trip charge. This warranty does not extend to any product or damage to a product caused by or attributable to freight damage, abuse, misuse, improper or abnormal usage or repairs not provided by an ICON authorized service center; products used for commercial or rental purposes; or products used as store display models. No other warranty beyond that specifically set forth above is authorized by ICON.

ICON is not responsible or liable for indirect, special or consequential damages arising out of or in connection with the use or performance of the product or damages with respect to any economic loss, loss of property, loss of revenues or profits, loss of enjoyment or use, costs of removal or installation or other consequential damages of whatsoever nature. Some states do not allow the exclusion or limitation of incidental or consequential damages. Accordingly, the above limitation may not apply to you.

The warranty extended hereunder is in lieu of any and all other warranties and any implied warranties of merchantability or fitness for a particular purpose is limited in its scope and duration to the terms set forth herein. Some states do not allow limitations on how long an implied warranty lasts. Accordingly, the above limitation may not apply to you.

This warranty gives you specific legal rights. You may also have other rights which vary from state to state.

ICON HEALTH & FITNESS, INC., 1500 S. 1000 W., LOGAN, UT 84321-9813