

# WEIDER<sup>®</sup> 200

PRECISION SYSTEM

Model No. WESY2037.0

Serial No. \_\_\_\_\_

Write the serial number in the space above for future reference.

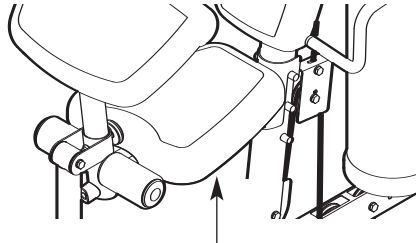

Serial Number Decal (under seat)

## USER'S MANUAL

### QUESTIONS?

As a manufacturer, we are committed to providing complete customer satisfaction. If you have questions, or if parts are damaged or missing, **PLEASE DO NOT CONTACT THE STORE;** please contact Customer Care.

**IMPORTANT:** You must note the product model number and serial number (see the drawing above) before contacting us:

CALL TOLL-FREE:

**1-877-992-5999**

Mon.–Fri. 6 a.m.–6 p.m. MST

Sat. 8 a.m.–4 p.m. MST

ON THE WEB:

[www.weiderservice.com](http://www.weiderservice.com)

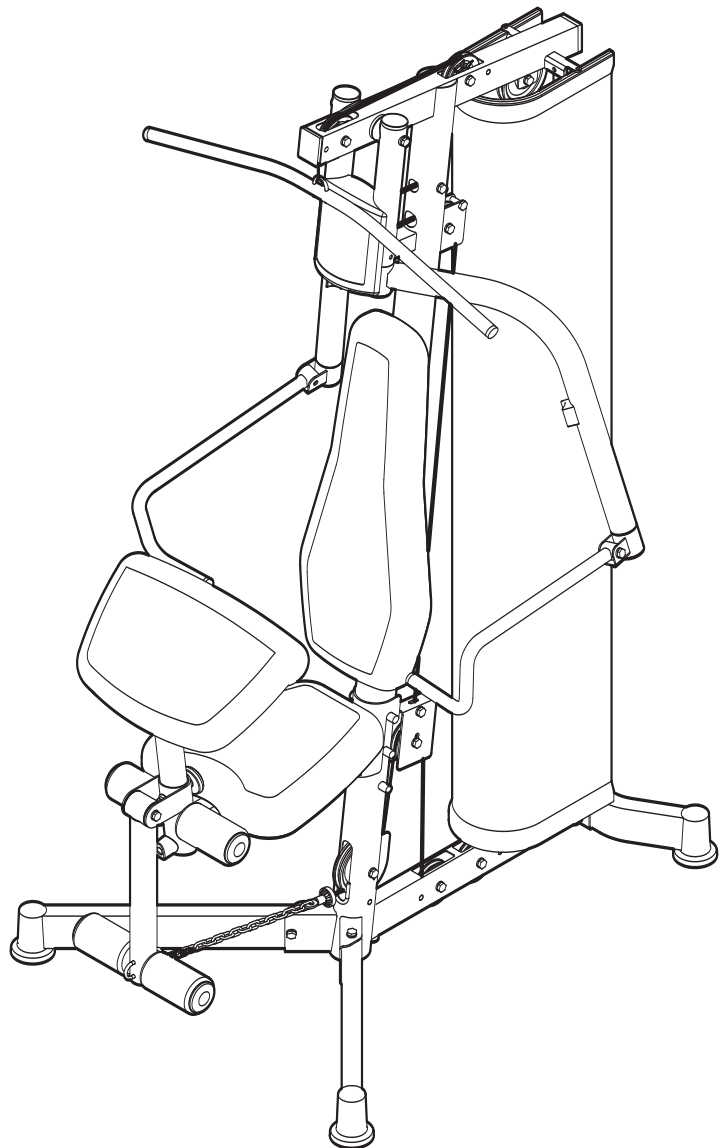

### ⚠ CAUTION

Read all precautions and instructions in this manual before using this equipment. Keep this manual for future reference.



Visit our website at

[www.weiderfitness.com](http://www.weiderfitness.com)

new products, prizes,  
fitness tips, and much more!

# TABLE OF CONTENTS

WARNING DECAL PLACEMENT ..... 2

IMPORTANT PRECAUTIONS ..... 3

BEFORE YOU BEGIN ..... 4

ASSEMBLY ..... 5

ADJUSTMENT ..... 8

WEIGHT RESISTANCE CHART ..... 12

MAINTENANCE ..... 13

CABLE DIAGRAM ..... 14

EXERCISE GUIDELINES ..... 15

PART LIST ..... 17

EXPLODED DRAWING ..... 18

ORDERING REPLACEMENT PARTS ..... Back Cover

LIMITED WARRANTY ..... Back Cover

## WARNING DECAL PLACEMENT

The warning decals shown here have been applied in the locations shown. **If a decal is missing or illegible, call the telephone number on the front cover of this manual and request a free replacement decal. Apply the decal in the location shown.** Note: The decals may not be shown at actual size.

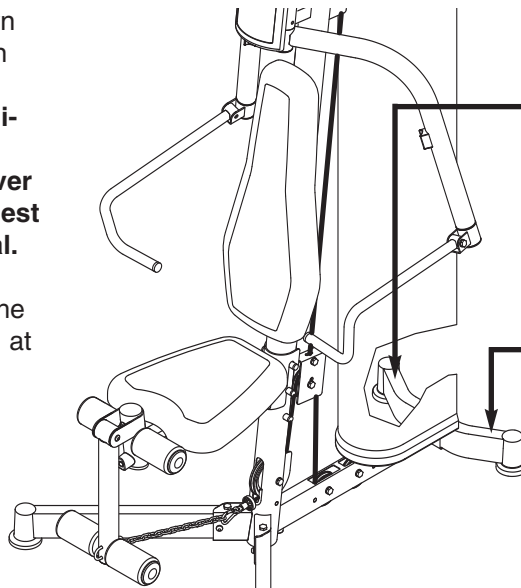

**⚠ WARNING**  
 User Weight: Max 300 LBS  
 Weight Crutch: Max 310 LBS  
 Leg Developer: Max 150 LBS  
 Weight Carriage: Max 150 LBS  
 Chest Fly Per Arm: Max 50 LBS  
 Product may not offer all listed exercises.

**⚠ WARNING**

- Misuse of this machine may result in serious injury.
- Read user's manual prior to use and follow all warnings and instructions.
- Do not allow children on or around machine.
- Keep body, clothing, and hair free and clear of all moving parts.
- Replace label if damaged, illegible, or removed.



# IMPORTANT PRECAUTIONS

**⚠️ WARNING:** To reduce the risk of serious injury, read all important precautions and instructions in this manual and all warnings on the weight system before using the weight system. ICON assumes no responsibility for personal injury or property damage sustained by or through the use of this product.

1. Before beginning any exercise program, consult your physician. This is especially important for persons over the age of 35 or persons with pre-existing health problems.
2. It is the responsibility of the owner to ensure that all users of the weight system are adequately informed of all precautions.
3. The weight system is intended for home use only. Do not use the weight system in a commercial, rental, or institutional setting.
4. Use the weight system only on a level surface. Cover the floor beneath the weight system to protect the floor.
5. Inspect and properly tighten all parts regularly. Replace any worn parts immediately.
6. Keep children under age 12 and pets away from the weight system at all times.
7. The weight system should not be used by persons weighing more than 300 lbs. (136 kg).
8. Wear appropriate exercise clothes when exercising; do not wear loose clothes that could become caught on the weight system.
9. Always wear athletic shoes for foot protection.
10. Keep hands and feet away from moving parts.
11. Always secure the weight stack with the lock pin and lock after exercising to prevent unauthorized use of the weight system (see LOCKING THE WEIGHT STACK on page 11).
12. Make sure that the cables remain on the pulleys at all times. If the cables bind as you are exercising, stop immediately and make sure that the cables are on the pulleys.
13. Never release the arms, leg lever, lat bar, or handle strap while weights are raised. The weights will fall with great force.
14. Always disconnect the lat bar from the weight system when performing an exercise that does not require the lat bar.
15. If you feel pain or dizziness while exercising, stop immediately and begin cooling down.
16. Use the weight system only as described in this manual.

# BEFORE YOU BEGIN

Thank you for selecting the versatile WEIDER® PRECISION SYSTEM 200 weight system. The weight system offers a selection of weight stations designed to develop every major muscle group of the body. Whether your goal is to tone your body, build dramatic muscle size and strength, or improve your cardiovascular system, the weight system will help you to achieve the specific results you want.

**For your benefit, read this manual carefully before using the weight system.** If you have questions after reading this manual, please see the front cover of this

manual. To help us assist you, note the product model number and serial number before contacting us. The model number and the location of the serial number decal are shown on the front cover of this manual.

**To avoid a registration fee for any service needed under warranty, you must register the weight system at [www.weiderservice.com/registration](http://www.weiderservice.com/registration).**

Before reading further, please review the drawing below and familiarize yourself with the parts that are labeled.

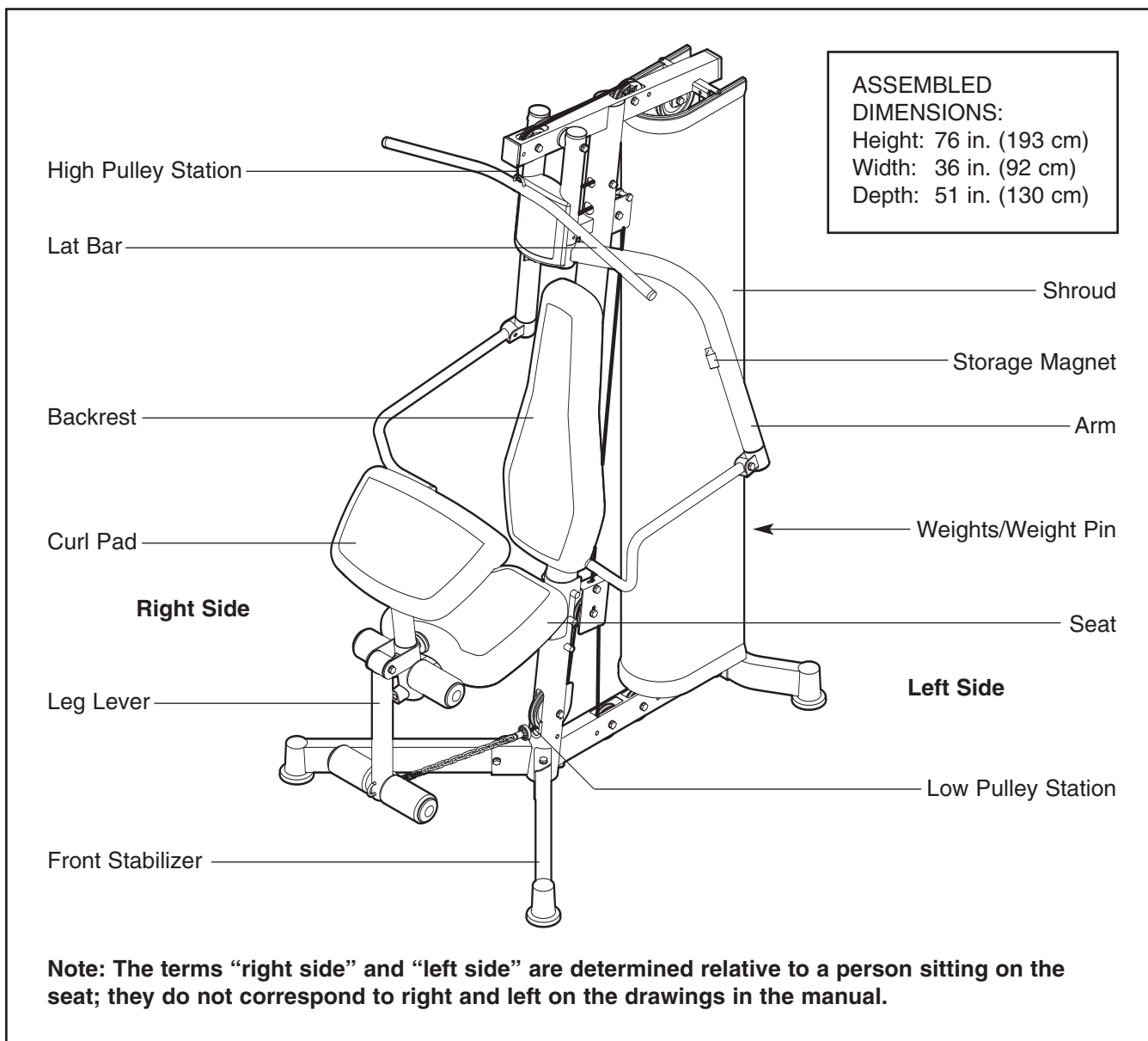

# ASSEMBLY

**For your convenience, the weight system is shipped almost fully assembled.** Before completing assembly, carefully read the following information and instructions.

- To hire an authorized service technician to assemble the weight system in your home, call 1-800-445-2480.
- Assembly requires the assistance of a second person.

- Because of its size and weight, the weight system should be assembled in the location where it will be used. Make sure that there is enough clearance to walk around the weight system.
- Place all parts in a cleared area and remove the packing materials. Do not dispose of the packing materials until assembly is completed.
- Assembly requires the included hex keys and grease and your own Phillips screwdriver.

1. With the help of another person, stand the weight system in the vertical position. **Have the other person hold the weight system securely until assembly step 1 is completed.**

**See the upper drawing.** Pivot the two Front Stabilizers (3) to the positions shown. Secure each Front Stabilizer to the Frame (1) with an M12 x 30mm Screw (72).

**See the lower drawing.** Orient the Rear Stabilizer (2) as shown. Attach the Rear Stabilizer to the Frame (1) with an M12 x 60mm Screw (77) and an M12 Washer (83).

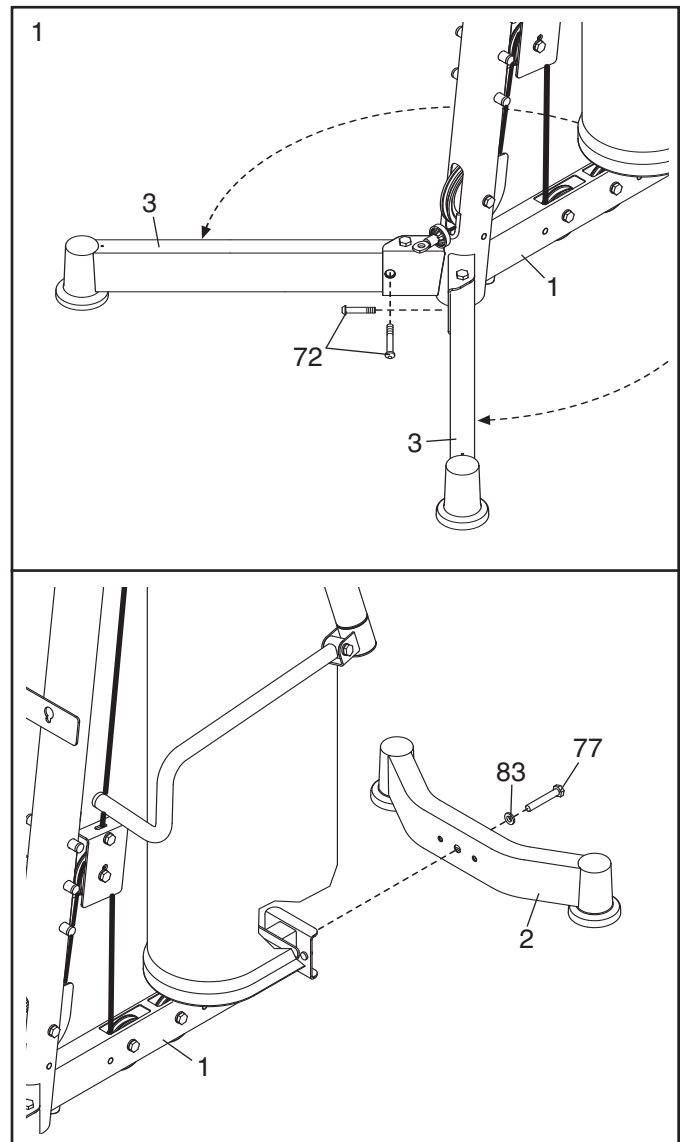

2. Locate the two Mounting Pegs (not shown) on the back of the Backrest (21). Insert the Mounting Pegs into the indicated brackets on the Frame (1), and then slide the Backrest downward.

Next, slide the Seat Frame (4) downward onto a set of pegs on the Frame (1).

Apply some of the included grease to the barrel of an M10 x 65mm Bolt Set (68). Attach the Leg Lever (5) to the Seat Frame (4) with the Bolt Set. **Make sure that the barrel of the Bolt Set is inserted through both sides of the bracket on the Seat Frame.**

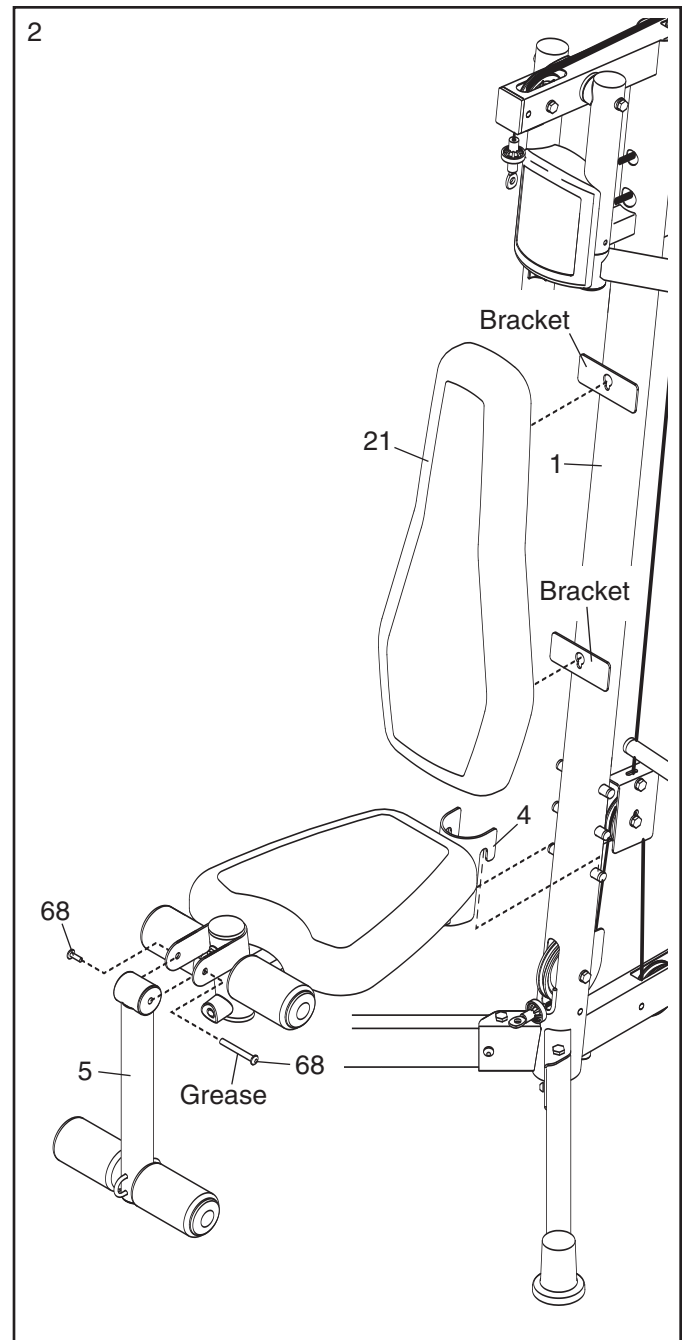

3. Remove the two M6 x 16mm Screws (67) from the Curl Pad (23). Attach the Curl Pad to the Curl Post (6) with the two Screws.

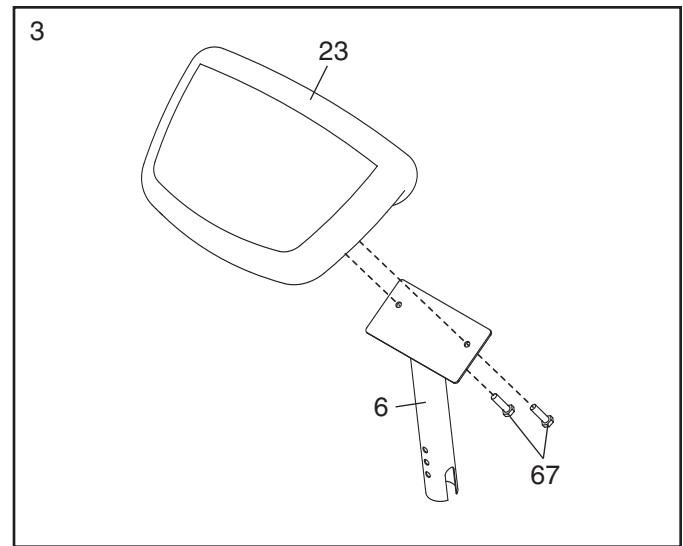

Make sure that all parts are properly tightened. The use of the remaining parts will be explained in ADJUSTMENT, beginning on page 8.

Before using the weight system, pull each cable a few times to make sure that the cables move smoothly around the pulleys. If one of the cables does not move smoothly, find and correct the problem. **IMPORTANT: If the cables are not properly installed, they may be damaged when heavy weight is used. See the CABLE DIAGRAM on page 14 for proper cable routing. If there is any slack in the cables, you will need to remove the slack by tightening the cables. See MAINTENANCE on page 13.**

# ADJUSTMENT

This section explains how to adjust the weight system. See the EXERCISE GUIDELINES on page 15 for important information about how to get the most benefit from your exercise program. Also, refer to the accompanying exercise guide to see the correct form for a variety of exercises.

Make sure all parts are properly tightened each time the weight system is used. Replace any worn parts immediately. The weight system can be cleaned with a damp cloth and a mild, non-abrasive detergent; **do not use solvents**.

## CHANGING THE WEIGHT SETTING

To change the weight setting of the weight stack, insert the Weight Pin (53) under the desired Weight (16) until the bent end of the Weight Pin touches the weight stack. Then, turn the bent end downward.

**Note: Due to the cables and pulleys, the amount of resistance at each exercise station may vary from the weight setting. Use the WEIGHT RESISTANCE CHART on page 12 to find the approximate amount of resistance at each weight station.**

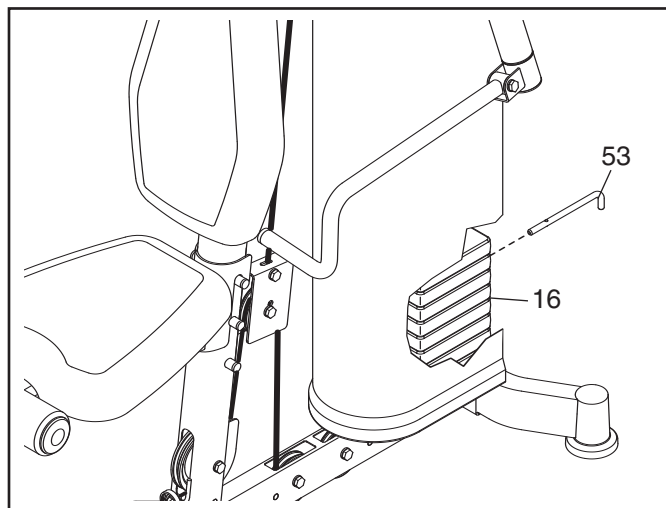

## ATTACHING ACCESSORIES TO THE HIGH PULLEY STATION

Attach the Lat Bar (42) to the High Cable (30) at the high pulley station with a Cable Clip (43). For some exercises, attach a Chain (44) between the Lat Bar and the Cable with two Cable Clips. **Adjust the length of the Chain between the Lat Bar and the Cable so that the Lat Bar is in the correct starting position for the exercise to be performed.**

Attach the Handle Strap (91) to the High Cable (30) in the same way.

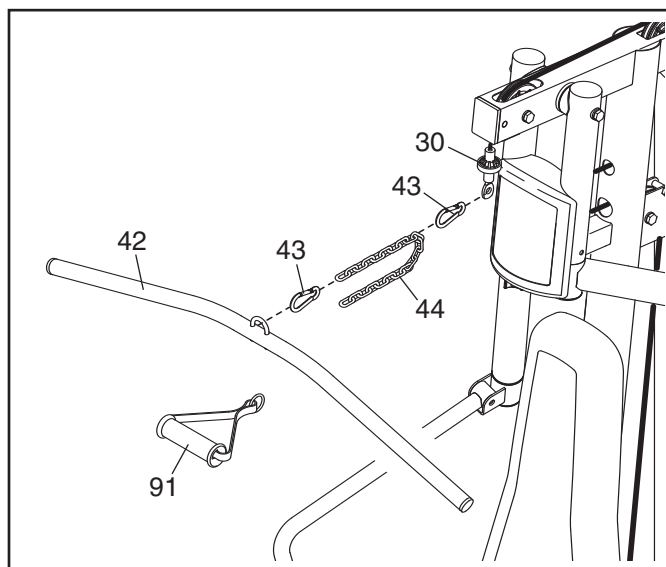



## ATTACHING ACCESSORIES TO THE LOW PULLEY STATION

To use accessories with the low pulley station, first remove the seat (see ATTACHING THE SEAT below).

Attach the Lat Bar (42) to the Low Cable (31) at the low pulley station with a Cable Clip (43). For some exercises, attach a Chain (44) between the Lat Bar and the Cable with two Cable Clips. **Adjust the length of the Chain between the Lat Bar and the Cable so that the Lat Bar is in the correct starting position for the exercise to be performed.**

Attach the Handle Strap (91) to the Low Cable (31) in the same way.

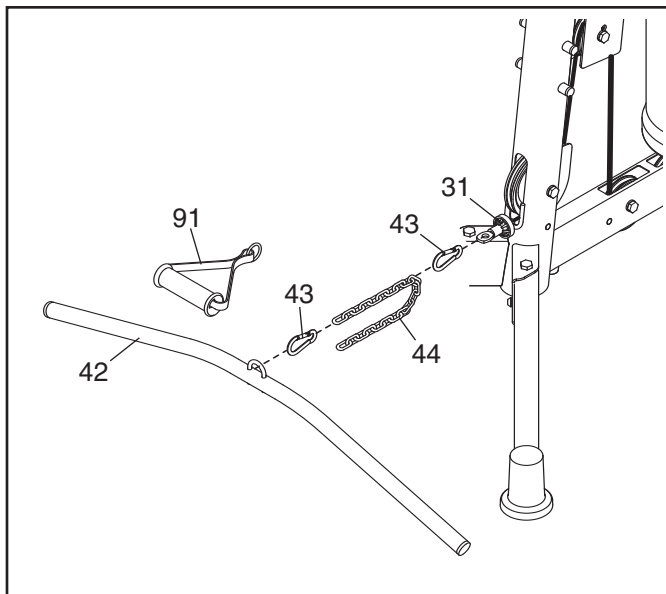

## ATTACHING THE SEAT

To use the Seat (22), slide the Seat Frame (4) onto a set of pegs on the Frame (1).

When the Seat (22) is not in use, set the Seat Frame (4) away from the weight system.

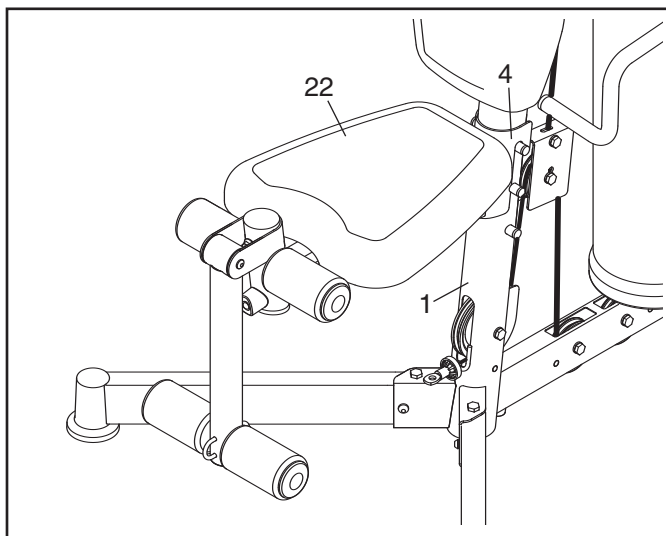

## USING THE PRESS ARMS

To use the Press Arms (7, 8) pull them away from the Press Arm Magnets (39) and lower them.

When the Press Arms (7, 8) are not in use, raise them until the Press Arm Magnets (39) hold them securely.

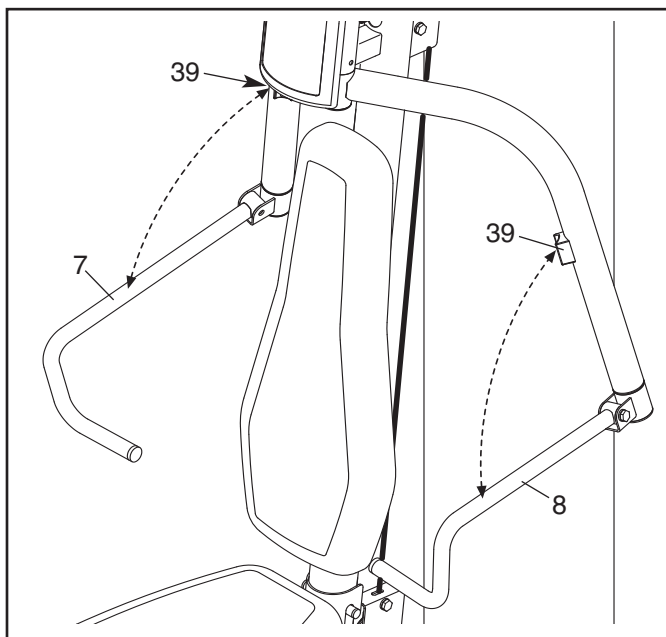

## CONNECTING THE LEG LEVER

To use the Leg Lever (5), first slide the Seat Frame (4) on a set of pegs on the Frame (1).

Next, attach a Chain (44) between the Leg Lever (5) and the Low Cable (31) with two Cable Clips (43).

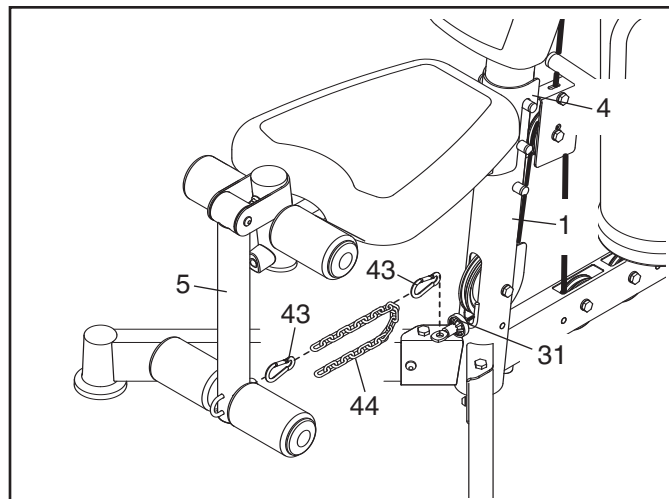

## USING THE CURL PAD

To use the Curl Pad (23), first remove the upper Seat Frame Cap (35) from the Seat Frame (4). Insert the Curl Post (13) into the Seat Frame, and secure it with the Curl Post Knob (47).

Next, attach the Lat Bar (42) to the Leg Lever (5) with a Chain (44) and two Cable Clips (43).

When performing an exercise that does not require the Curl Pad (23), remove the Curl Pad and insert the Seat Frame Cap (35) into the Seat Frame (4).

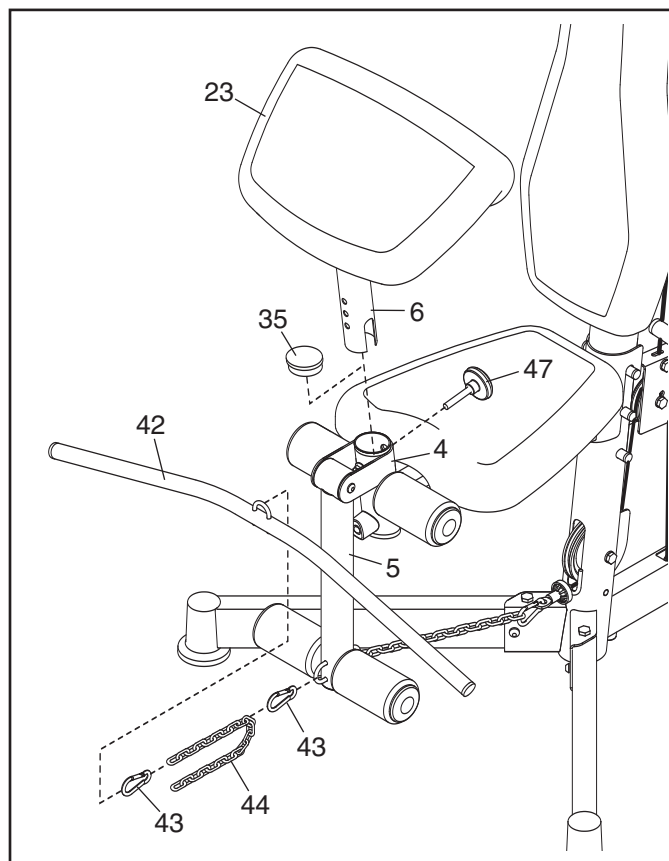

## LOCKING THE WEIGHT STACK

Lock the weight stack by inserting the Lock Pin (54) into one of the Weight Guides (19) and securing the Lock (55) onto the Lock Pin.

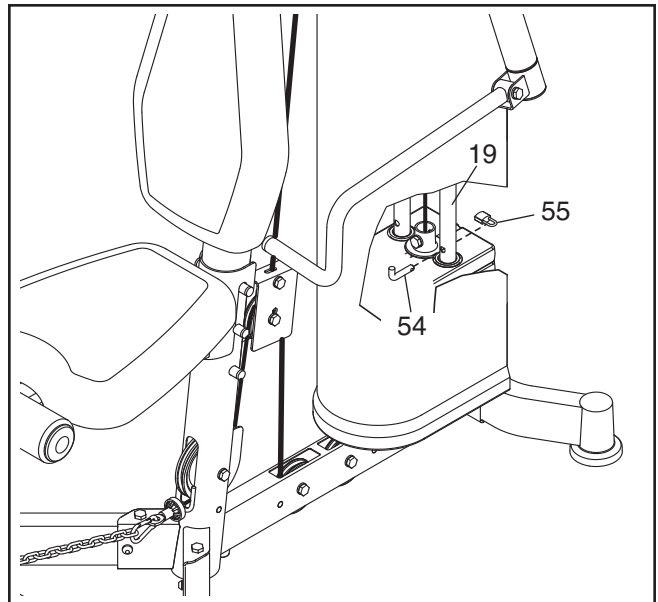

---

# WEIGHT RESISTANCE CHART

The chart below shows the approximate weight resistance at each exercise station. The numbers in the left column refer to the 10-lb. weights. **Note: The actual resistance at each station may vary due to differences in individual weights as well as friction between the cables, pulleys, and weight guides.**

WEIGHT	PRESS ARM (lbs.)	HIGH PULLEY (lbs.)	LEG LEVER (lbs.)	LOW PULLEY (lbs.)
1	44	24	40	48
2	64	31	64	69
3	83	41	83	99
4	104	57	104	118
5	123	66	123	139
6	145	78	145	160
7	170	86	170	185
8	199	99	199	222

Note: 1 lb. = 2.2 kg

# MAINTENANCE

Make sure all parts are properly tightened each time the weight system is used. Replace any worn parts immediately. The weight system can be cleaned with a damp cloth and a mild, non-abrasive detergent. Do not use solvents.

## TIGHTENING THE CABLES

Woven cable, the type of cable used on the weight system, can stretch slightly when it is first used. If there is slack in the cables before resistance is felt, the cables should be tightened.

To tighten the cables, first insert the weight pin (not shown) into the center of the weight stack (not shown). Next, locate the upper or lower U-bracket (18). Remove the M10 Nylon Locknut (57) and the M10 x 50mm Bolt (64) from the U-bracket, the 90mm Pulley (27), and the Cable Trap (51). Reattach the Pulley and the Cable Trap to the U-bracket using the hole closer to the center of the U-bracket. **Make sure that the Cable Trap is in the proper position and that the High Cable (30) or the Low Cable (31) is between the Cable Trap and the Pulley.**

**To further tighten the cables, move the 90mm Pulley (27) in the other U-bracket (18).**

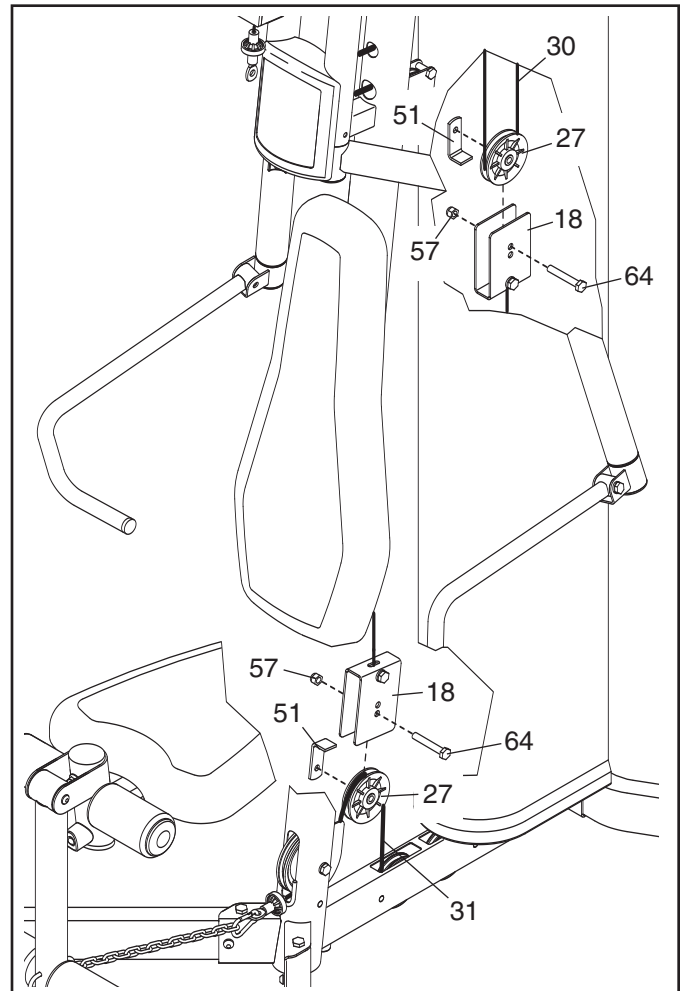

**Do not overtighten the cables. If the cables are overtightened, the top weight will be lifted off the weight stack. If a cable tends to slip off the pulleys often, it may have become twisted. Remove the cable and reinstall it.** If the cables need to be replaced, see ORDERING REPLACEMENT PARTS on the back cover of this manual.

# CABLE DIAGRAM

The diagram below shows the proper routing of the cables. The numbers in each drawing show the proper route for that cable. Use the diagram to make sure that the cables and the cable traps are assembled correctly. If the cables are not assembled correctly, the weight system will not function properly and damage may occur. **Make sure that the cable traps do not touch or bind the cables.**

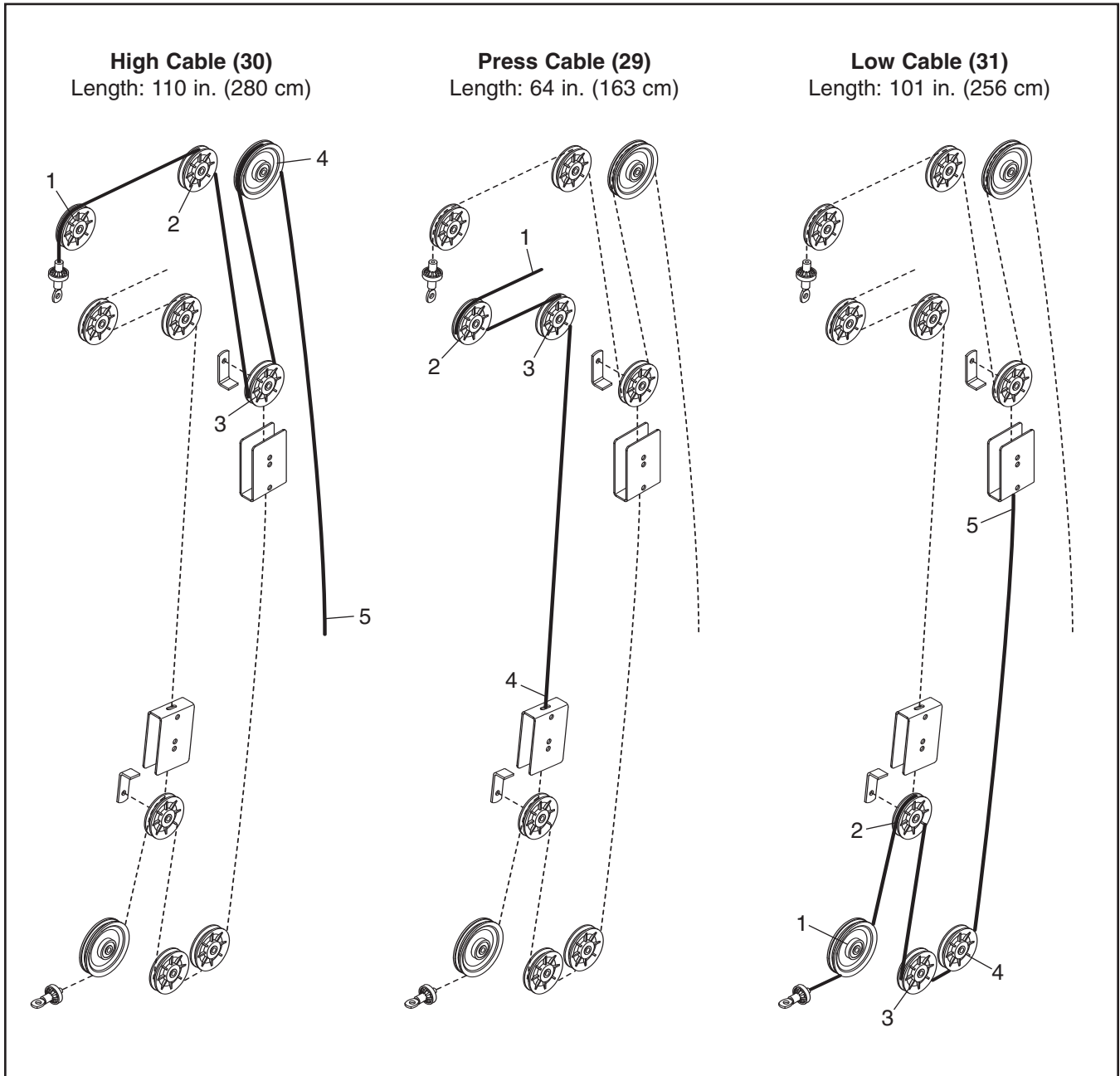

---

# EXERCISE GUIDELINES

## THE FOUR BASIC TYPES OF WORKOUTS

### Muscle Building

To increase the size and strength of your muscles, push them close to their maximum capacity. Your muscles will continually adapt and grow as you progressively increase the intensity of your exercise. You can adjust the intensity level of an individual exercise in two ways:

- by changing the amount of resistance used
- by changing the number of repetitions or sets performed. (A “repetition” is one complete cycle of an exercise, such as one sit-up. A “set” is a series of repetitions.)

The proper amount of resistance for each exercise depends upon the individual user. You must gauge your limits and select the amount of resistance that is right for you. Begin with 3 sets of 8 repetitions for each exercise you perform. Rest for 3 minutes after each set. When you can complete 3 sets of 12 repetitions without difficulty, increase the amount of resistance.

### Toning

You can tone your muscles by pushing them to a moderate percentage of their capacity. Select a moderate amount of resistance and increase the number of repetitions in each set. Complete as many sets of 15 to 20 repetitions as possible without discomfort. Rest for 1 minute after each set. Work your muscles by completing more sets rather than by using high amounts of resistance.

### Weight Loss

To lose weight, use a low amount of resistance and increase the number of repetitions in each set. Exercise for 20 to 30 minutes, resting for a maximum of 30 seconds between sets.

### Cross Training

Cross training is an efficient way to get a complete and well-balanced fitness program. An example of a balanced program follows:

- Plan strength training workouts on Monday, Wednesday, and Friday.
- Plan 20 to 30 minutes of aerobic exercise, such as running on a treadmill or riding on an elliptical exerciser or exercise cycle, on Tuesday and Thursday.
- Rest from both strength training and aerobic exercise for at least one full day each week to give your body time to regenerate.

The combination of strength training and aerobic exercise will reshape and strengthen your body, plus develop your heart and lungs.

## PERSONALIZING YOUR EXERCISE PROGRAM

Determining the appropriate length of time for each workout, and the numbers of repetitions and sets to complete, is an individual matter. Avoid overdoing it during the first few months of your exercise program. Progress at your own pace and be sensitive to your body’s signals. If you experience pain or dizziness while exercising, stop immediately and cool down. Find out what is wrong before continuing. Remember that adequate rest and a proper diet are important factors in any exercise program.

### WARMING UP

Begin each workout with 5 to 10 minutes of stretching and light exercise to warm up. Warming up prepares your body for more strenuous exercise by increasing circulation, raising your body temperature and delivering more oxygen to your muscles.

### WORKING OUT

Each workout should include 6 to 10 different exercises. Select exercises for every major muscle group, emphasizing areas that you want to develop most. To give balance and variety to your workouts, vary the exercises from workout to workout.

Schedule your workouts for the time of day when your energy level is the highest. Each workout should be followed by at least one day of rest. Once you find the schedule that is right for you, stick with it.

### EXERCISE FORM

Maintaining proper form is an essential part of an effective exercise program. This requires moving through the full range of motion for each exercise, and moving only the appropriate parts of the body. Exercising in an uncontrolled way will leave you feeling exhausted. On the exercise guide accompanying this manual you will find photographs showing the correct form for several exercises, and a list of the muscles affected. See the muscle chart on the next page to find the names of the muscles.

The repetitions in each set should be performed smoothly and without pausing. The exertion stage of each repetition should last about half as long as the return stage. Proper breathing is important. Exhale during the exertion stage of each repetition and inhale during the return stroke. Never hold your breath.

The repetitions in each set should be performed smoothly and without pausing. The exertion stage of each repetition should last about half as long as the return stage. Proper breathing is important. Exhale during the exertion stage of each repetition and inhale during the return stroke. Never hold your breath.

Rest for a short period of time after each set. The ideal resting periods are:

- Rest for three minutes after each set for a muscle building workout.
- Rest for one minute after each set for a toning workout.
- Rest for 30 seconds after each set for a weight loss workout.

Plan to spend the first couple of weeks familiarizing yourself with the equipment and learning the proper form for each exercise.

## COOLING DOWN

End each workout with 5 to 10 minutes of stretching. Include stretches for both your arms and legs. Move slowly as you stretch and do not bounce. Ease into each stretch gradually and go only as far as you can without strain. Stretching at the end of each workout is an effective way to increase flexibility.

## STAYING MOTIVATED

For motivation, keep a record of each workout. Write the date, the exercises performed, the resistance used, and the numbers of sets and repetitions completed. Record your weight and key body measurements at the end of every month. The key to achieving the greatest results is to make exercise a regular and enjoyable part of your everyday life.

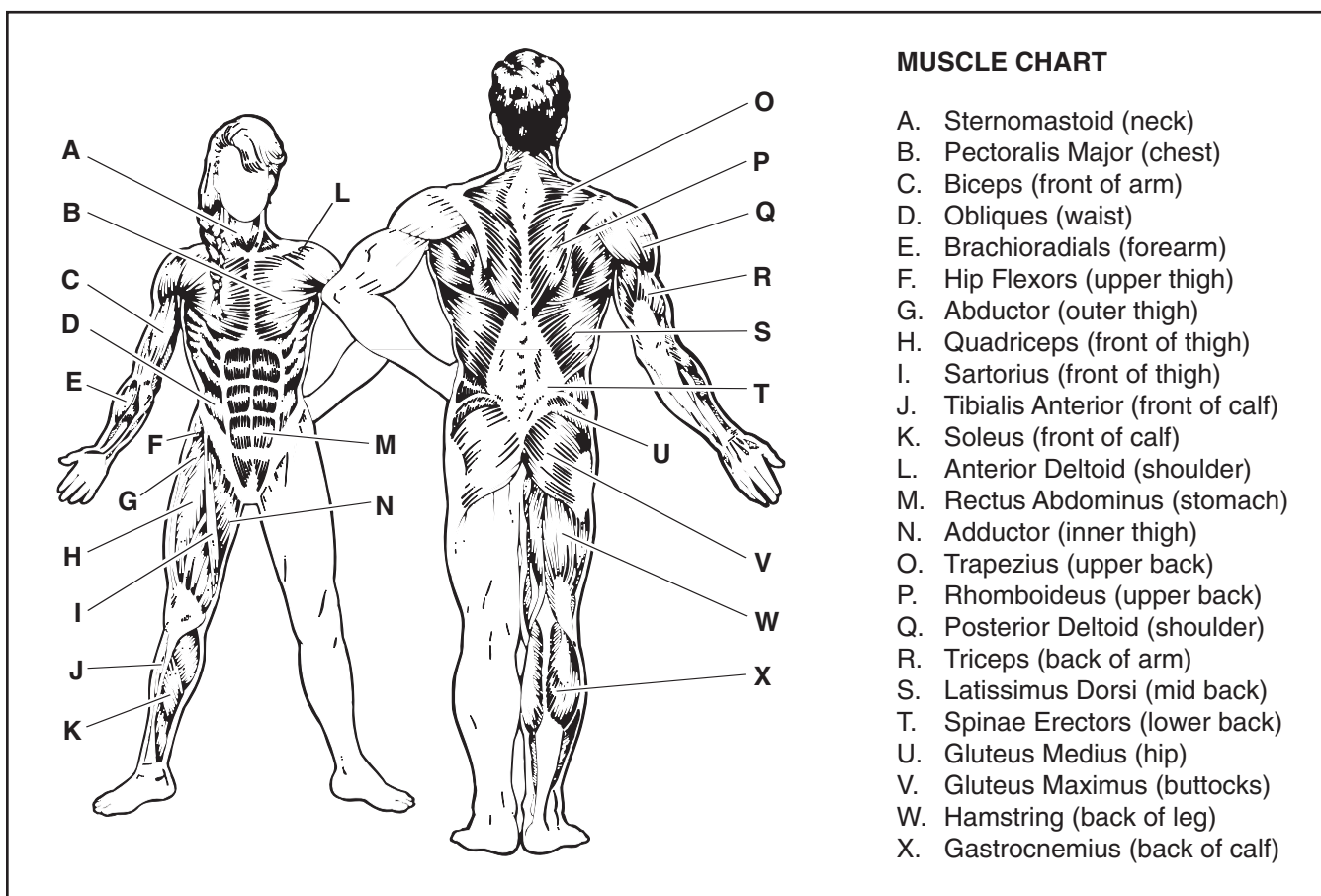



# PART LIST—Model No. WESY2037.0

R0807B

Key No.	Qty.	Description	Key No.	Qty.	Description
1	1	Frame	49	4	12.5mm Square Inner Cap
2	1	Rear Stabilizer	50	2	63mm x 50mm Inner Cap
3	2	Front Stabilizer	51	2	Cable Trap
4	1	Seat Frame	52	1	Frame Foot
5	1	Leg Lever	53	1	Weight Pin
6	1	Curl Post	54	1	Lock Pin
7	1	Right Press Arm	55	1	Lock
8	1	Left Press Arm	56	1	M12 x 200mm Bolt
9	2	Pivot Bracket	57	18	M10 Nylon Locknut
10	2	Arm	58	1	M6 Nylon Locknut
11	1	Press Frame	59	18	M10 Washer
12	1	Shroud	60	3	M6 Washer
13	2	Shroud Bracket	61	1	M10 x 197mm Bolt
14	1	Weight Tube	62	2	M4 x 12mm Self-tapping Screw
15	1	Weight Tube Cap	63	4	M10 x 65mm Screw
16	8	Weight	64	7	M10 x 50mm Bolt
17	1	Weight Base	65	2	M10 x 80mm Bolt
18	2	U-bracket	66	1	M6 x 45mm Screw
19	2	Weight Guide	67	4	M6 x 16mm Screw
20	4	Stabilizer Foot	68	1	M10 x 65mm Bolt Set
21	1	Backrest	69	4	M4 Washer
22	1	Seat	70	2	M10 x 45mm Bolt
23	1	Curl Pad	71	2	M10 x 92mm Bolt
24	1	Press Frame Cover	72	2	M12 x 30mm Screw
25	4	Foam Pad	73	12	M4 x 20mm Self-tapping Screw
26	2	115mm Pulley	74	4	M6 x 30mm Bolt
27	8	90mm Pulley	75	2	M8 Nylon Locknut
28	2	Pulley Plate	76	2	M8 Washer
29	1	Press Cable	77	1	M12 x 60mm Screw
30	1	High Cable	78	2	M10 x 100mm Bolt
31	1	Low Cable	79	2	M8 x 40mm Bolt
32	1	38mm Square Inner Cap	80	2	Large Washer
33	3	50mm Round Inner Cap	81	2	M10 x 55mm Bolt
34	4	Pivot Bracket Bushing	82	1	M12 Nylon Locknut
35	2	Seat Frame Cap	83	1	M12 Washer
36	4	Stabilizer Bushing	84	1	M6 x 38mm Bolt
37	16	Weight Bushing	85	2	M6 x 20mm Bolt
38	2	Press Frame Bushing	86	2	Mounting Peg
39	2	Press Arm Magnet	87	2	Leg Lever Bushing
40	4	Foam Pad Cap	88	2	Arm Cap
41	2	25.5mm Pulley Spacer	89	6	16mm Round Inner Cap
42	1	Lat Bar	90	1	Weight Tube Cap
43	4	Cable Clip	91	1	Handle Strap
44	2	Chain	92	4	13mm x 26mm Inner Cap
45	4	25mm Round Inner Cap	*	—	User's Manual
46	1	Leg Lever Bumper	*	—	Exercise Guide
47	1	Curl Post Knob	*	—	Grease Packet
48	4	6.5mm Pulley Spacer	*	—	Hex Key

Note: Specifications are subject to change without notice. See the back cover of this manual for information about ordering replacement parts. \*These parts are not illustrated.

# EXPLODED DRAWING A—Model No. WESY2037.0

R0807B

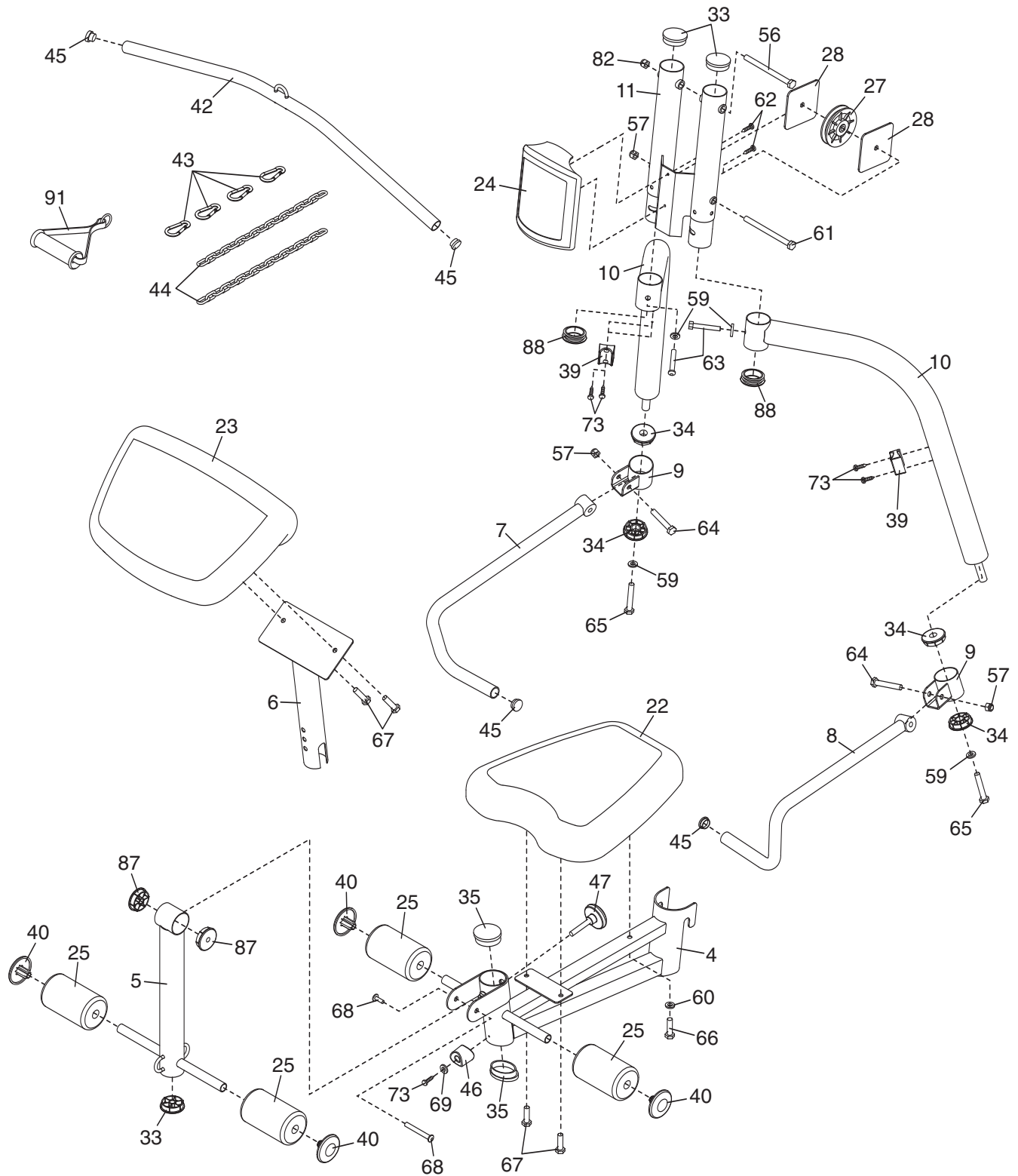

# EXPLODED DRAWING B—Model No. WESY2037.0

R0807B

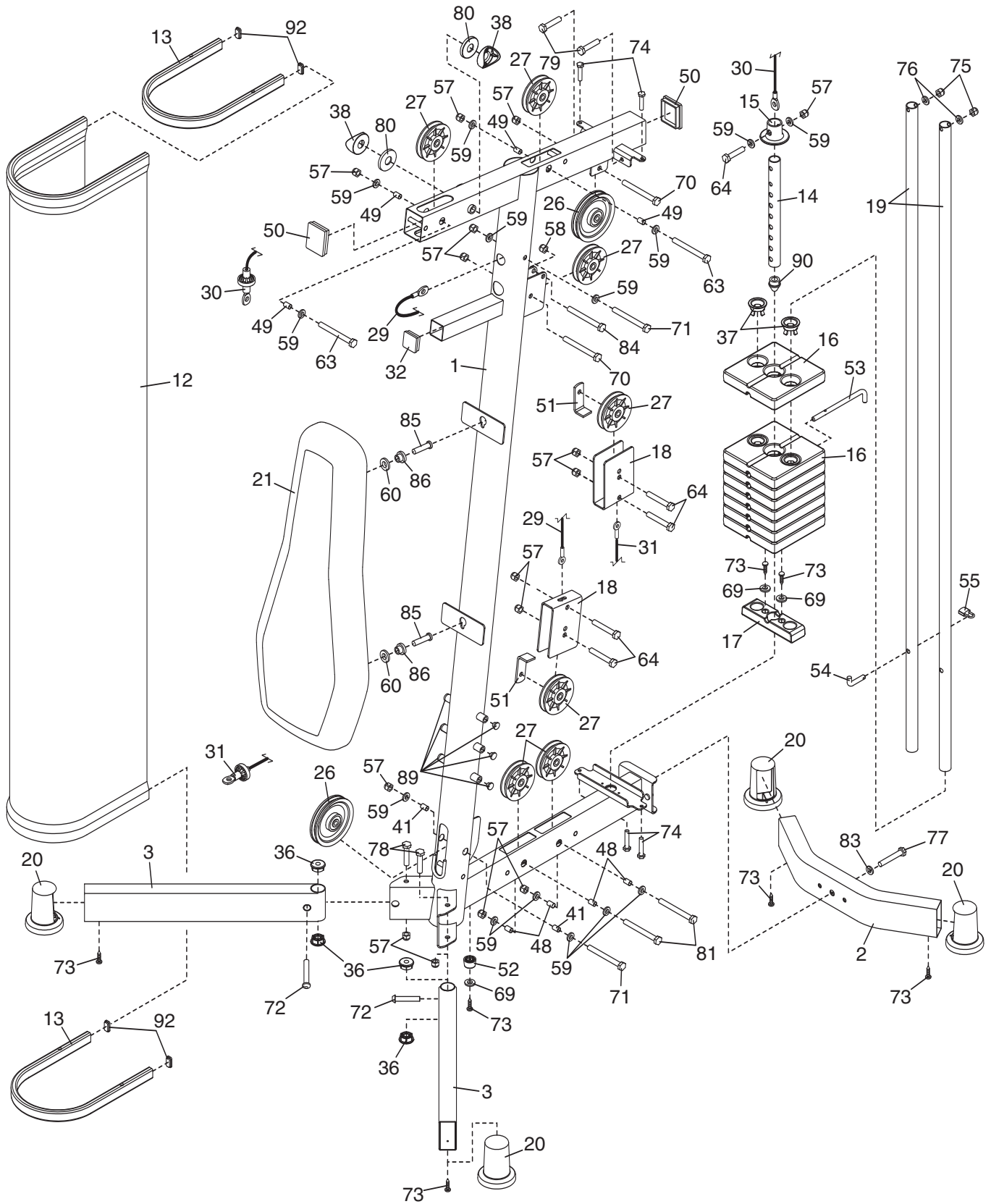

---

# ORDERING REPLACEMENT PARTS

To order replacement parts, please see the front cover of this manual. To help us assist you, be prepared to provide the following information when contacting us:

- the model number and serial number of the product (see the front cover of this manual)
- the name of the product (see the front cover of this manual)
- the key number and description of the replacement part(s) (see the PART LIST and the EXPLODED DRAWING near the end of this manual)

## LIMITED WARRANTY

ICON Health & Fitness, Inc. (ICON) warrants this product to be free from defects in workmanship and material, under normal use and service conditions, for a period of ninety (90) days from the date of purchase. This warranty extends only to the original purchaser. ICON's obligation under this warranty is limited to replacing or repairing, at ICON's option, the product through one of its authorized service centers. All repairs for which warranty claims are made must be pre-authorized by ICON. If the product is shipped to a service center, freight charges to and from the service center will be the customer's responsibility. For in-home service, the customer will be responsible for a minimal trip charge. This warranty does not extend to any product or damage to a product caused by or attributable to freight damage, abuse, misuse, improper or abnormal usage or repairs not provided by an ICON authorized service center; products used for commercial or rental purposes; or products used as store display models. No other warranty beyond that specifically set forth above is authorized by ICON.

ICON is not responsible or liable for indirect, special or consequential damages arising out of or in connection with the use or performance of the product or damages with respect to any economic loss, loss of property, loss of revenues or profits, loss of enjoyment or use, costs of removal or installation or other consequential damages of whatsoever nature. Some states do not allow the exclusion or limitation of incidental or consequential damages. Accordingly, the above limitation may not apply to you.

The warranty extended hereunder is in lieu of any and all other warranties and any implied warranties of merchantability or fitness for a particular purpose is limited in its scope and duration to the terms set forth herein. Some states do not allow limitations on how long an implied warranty lasts. Accordingly, the above limitation may not apply to you.

This warranty gives you specific legal rights. You may also have other rights which vary from state to state.

**ICON HEALTH & FITNESS, INC., 1500 S. 1000 W., LOGAN, UT 84321-9813**