

WEIDER[®] PRO 245

Model No. 831.15679.0

Serial No. _____

Write the serial number in the space above for future reference.

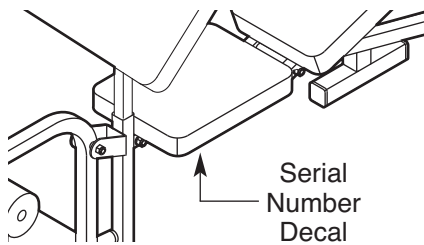

WEIGHT BENCH EXERCISER User's Manual

- Assembly
- Adjustments
- Part List and Drawing

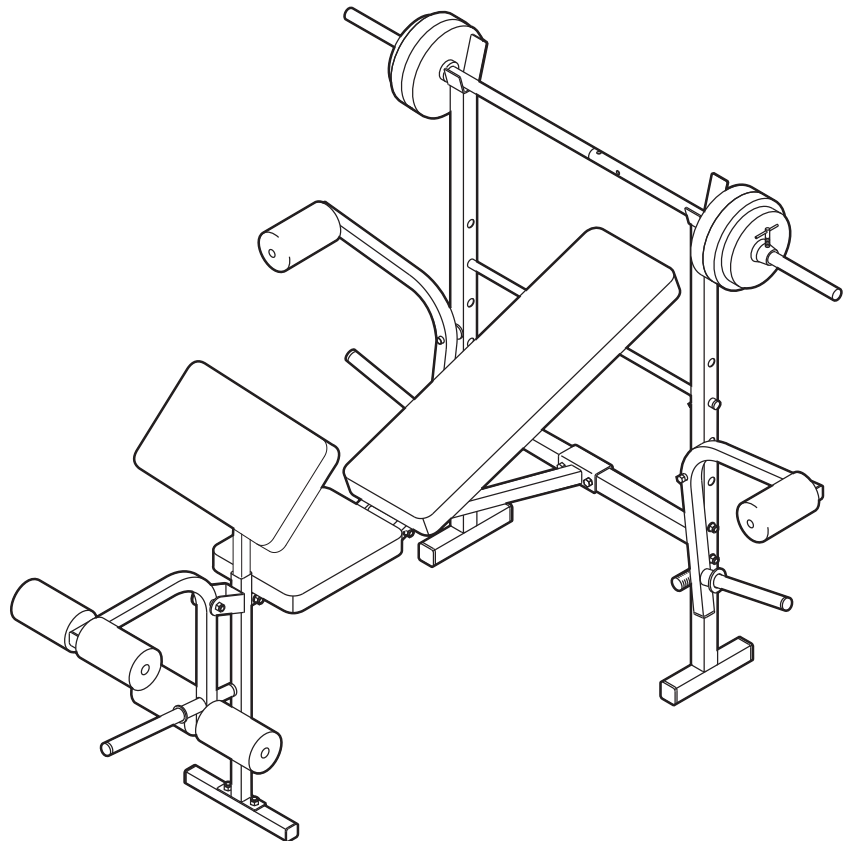

⚠ CAUTION

Read all precautions and instructions in this manual before using this equipment. Save this manual for future reference.

Sears, Roebuck and Co., Hoffman Estates, IL 60179

TABLE OF CONTENTS

WARNING DECAL PLACEMENT2
IMPORTANT PRECAUTIONS3
BEFORE YOU BEGIN4
ASSEMBLY5
ADJUSTMENTS9
EXERCISE GUIDELINES10
ORDERING REPLACEMENT PARTSBack Cover
FULL 90-DAY WARRANTYBack Cover

Note: A PART IDENTIFICATION CHART and a PART LIST/EXPLODED DRAWING are attached in the center of this manual. Remove the PART IDENTIFICATION CHART and PART LIST/EXPLODED DRAWING before beginning assembly.

WARNING DECAL PLACEMENT

The decals shown here have been placed on the weight bench. If the decal is missing or illegible, please call toll-free 1-877-992-5999, Monday through Friday, 6 a.m. until 6 p.m. Mountain Time, and order a free replacement decal. Apply the decal in the location shown.

⚠ WARNING

- Misuse of this machine may result in serious injury.
- Read user's manual prior to use and follow all warnings and instructions.
- Do not allow children on or around machine.
- Keep body, clothing, and hair free and clear of all moving parts.
- Replace label if damaged, illegible, or removed.

⚠ WARNING

Keep hands and fingers clear of this area.

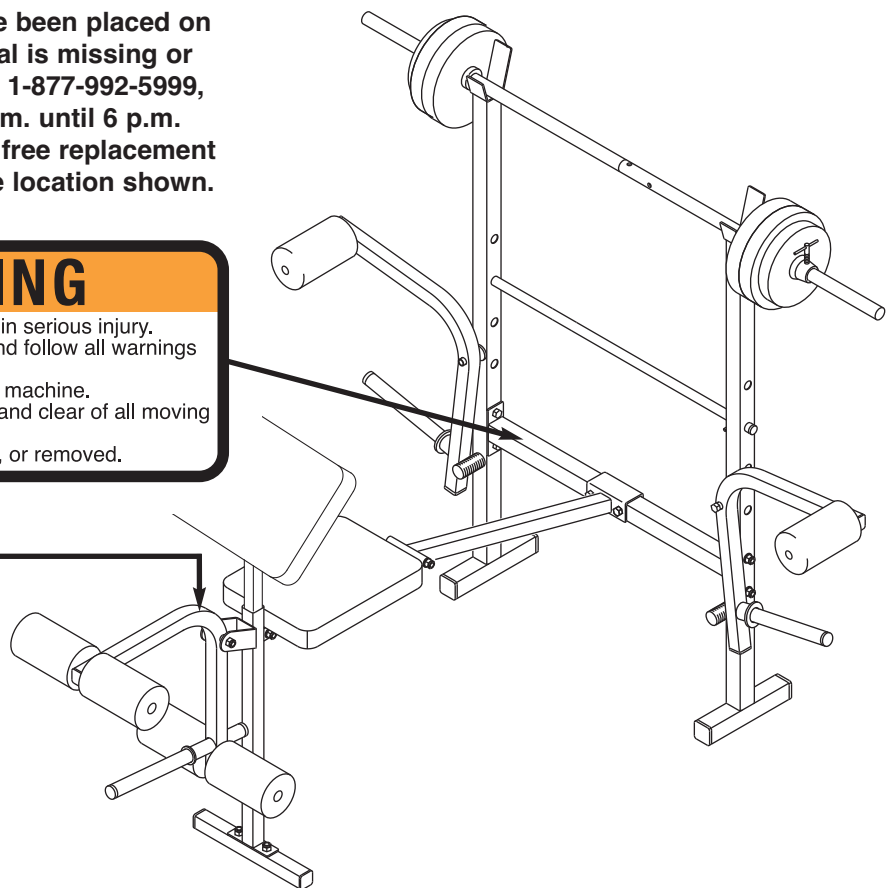

IMPORTANT PRECAUTIONS

⚠ WARNING: To reduce the risk of serious injury, read the following important precautions before using the weight bench.

1. Read all instructions in this manual and all warnings on the weight bench before using the weight bench. Use the weight bench only as described in this manual.
2. It is the responsibility of the owner to ensure that all users of the weight bench are adequately informed of all precautions.
3. The weight bench is intended for home use only. Do not use the weight bench in any commercial, rental, or institutional setting.
4. Keep the weight bench indoors, away from moisture and dust. Place the weight bench on a level surface, with a mat beneath it to protect the floor or carpet. Make sure that there is enough clearance around the weight bench to mount, dismount, and use the weight bench.
5. Inspect and properly tighten all parts regularly. Replace any worn parts immediately.
6. Keep children under the age of 12 and pets away from the weight bench at all times.
7. Keep hands and feet away from moving parts.
8. Always wear athletic shoes for foot protection while exercising.
9. The weight bench is designed to support a maximum user weight of 300 pounds, and a maximum total weight of 410 pounds. Do not place more than 110 pounds, including a barbell and weights, on the weight rests. Do not place more than 30 pounds on each fly arm. Do not place more than 50 pounds on the leg lever.
10. Do not use a barbell that is longer than five feet with the weight bench.
11. Always make sure there is an equal amount of weight on each side of your barbell when you are using it. When adding or removing weights, always keep some weight on both ends of the barbell to prevent the barbell from tipping.
12. When you are using the leg lever, place a barbell with the same amount of weight on the weight rests to balance the bench.
13. When using the backrest in an inclined or level position, make sure that the support rod is inserted completely through the uprights and turned to the locked position.
14. If you feel pain or dizziness at any time while exercising, stop immediately and begin cooling down.

⚠ WARNING: Before beginning this or any exercise program, consult your physician. This is especially important for persons over the age of 35 or persons with pre-existing health problems. Read all instructions before using. Sears assumes no responsibility for personal injury or property damage sustained by or through the use of this product.

BEFORE YOU BEGIN

Thank you for selecting the WEIDER® PRO 245 weight bench. The versatile weight bench is designed to develop every major muscle group of the body. Whether your goal is a shapely figure, dramatic muscle size and strength, or a healthier cardiovascular system, the weight bench will help you to achieve the specific results you want.

For your benefit, read this manual carefully before using the weight bench. If you have questions after

reading this manual, call 1-800-4-MY-HOME® (1-800-469-4663). To help us assist you, please note the product model number and serial number before calling. The model number is 831.15679.0. The serial number can be found on a decal attached to the weight bench (see the front cover of this manual).

Before reading further, please look at the drawing below and familiarize yourself with the parts that are labeled.

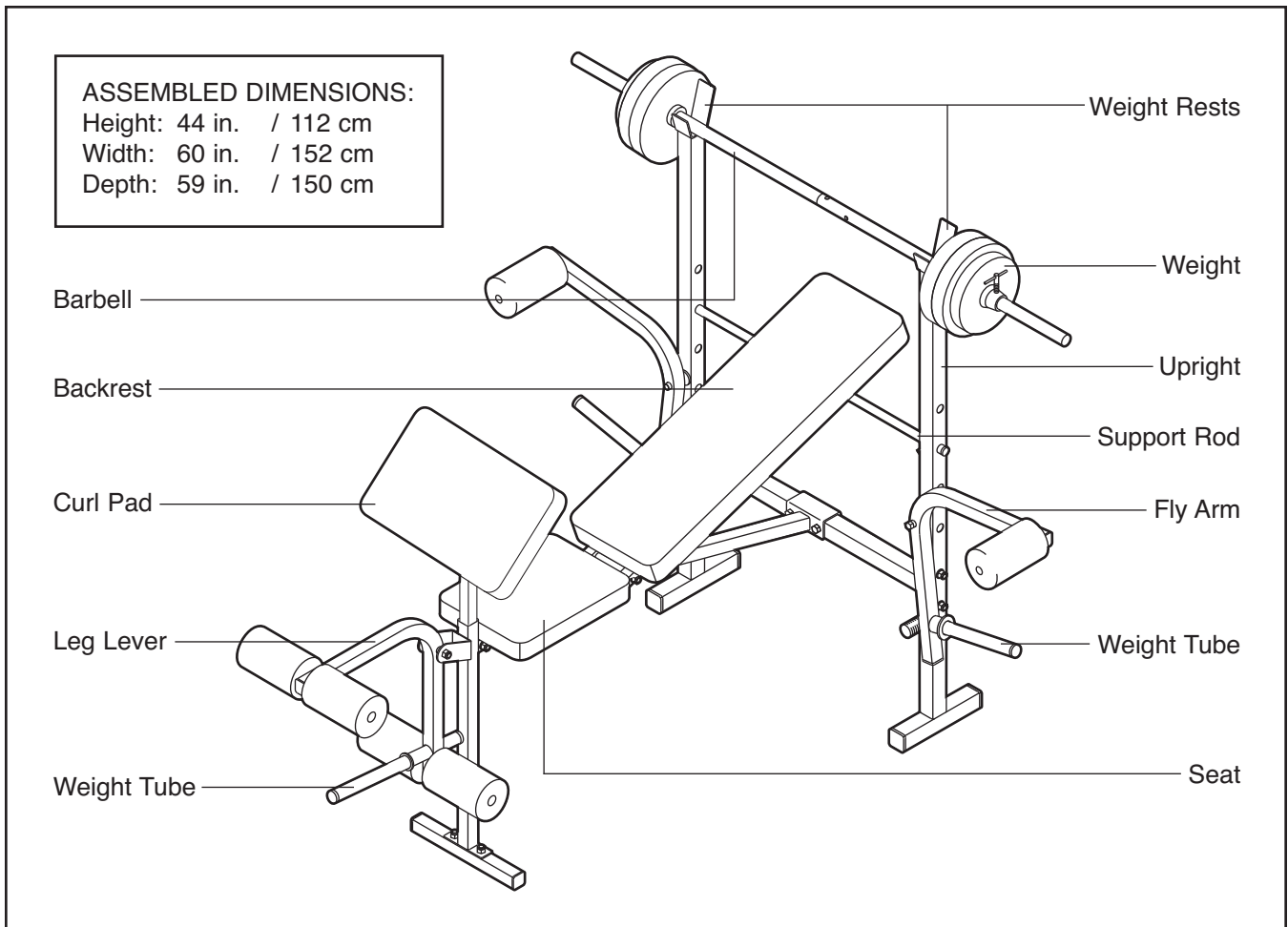

ASSEMBLY

Make Things Easier for Yourself



This manual is designed to ensure that the weight bench can be assembled successfully by anyone. Most people find that by setting aside plenty of time, assembly will go smoothly.

Before beginning assembly, carefully read the following information and instructions:

- Assembly requires two people.
- For help identifying small parts, see the **PART IDENTIFICATION CHART**.
- Tighten all parts as you assemble them, unless instructed to do otherwise.
- As you assemble the weight bench, make sure all parts are oriented as shown in the drawings.

- Place all parts in a cleared area and remove the packing materials. Do not dispose of the packing materials until assembly is completed.

The included grease, and the following tools (not included) may be required for assembly:

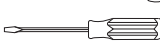
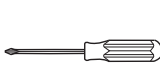
- **Two adjustable wrenches** 
- **One hammer** 
- **One standard screwdriver** 
- **One Phillips screwdriver** 
- **Clear tape or masking tape, and soapy water.**

Assembly will be more convenient if you have a socket set, a set of open-end or closed-end wrenches, or a set of ratchet wrenches.

1. **Before assembling the weight bench, make sure that you have read and understand the information in the box above. For help identifying small parts, see the PART IDENTIFICATION CHART.**

Orient the Crossbar (3) so that the decal is in the position shown. Attach the Crossbar to an Upright (1) with two M8 x 55mm Bolts (18), two M8 Washers (16), and two M8 Nylon Locknuts (17). **Do not tighten the Locknuts yet.**

Repeat this step with the other Upright (1).

2. Attach the Front Leg (8) to the Stabilizer (13) with two M8 x 42mm Carriage Bolts (37) and two M8 Nylon Locknuts (17). **Note: The indents around the holes on one side of the Stabilizer must be on the bottom. Do not tighten the Locknuts yet.**

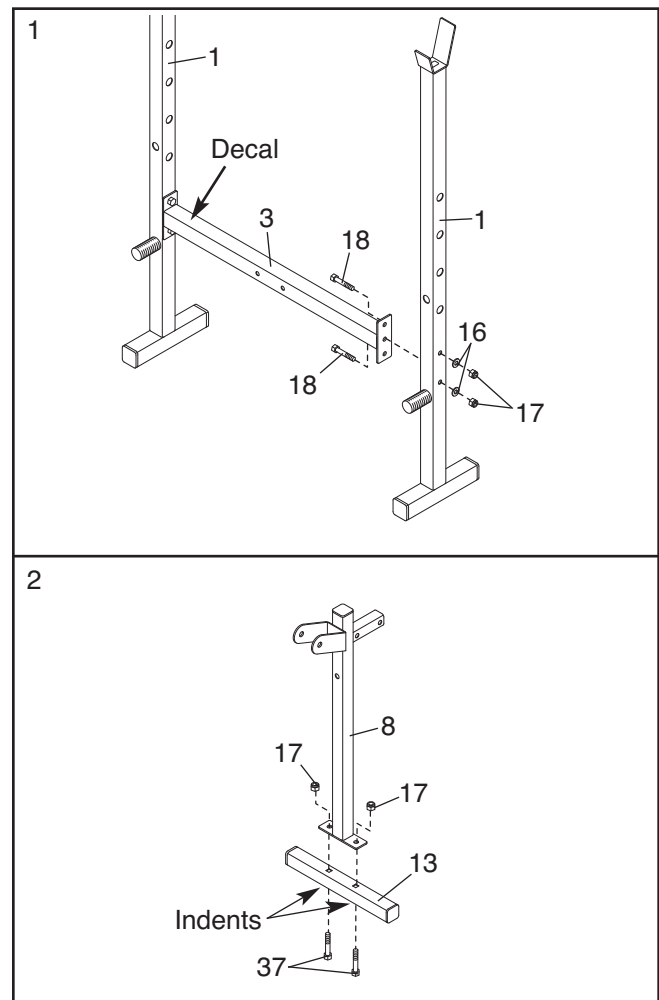

- Attach the Front Leg (8) to the Frame (2) with two M8 x 43mm Bolts (39), four M8 Washers (16), and two M8 Nylon Locknuts (17). **Do not tighten the Locknuts yet.**

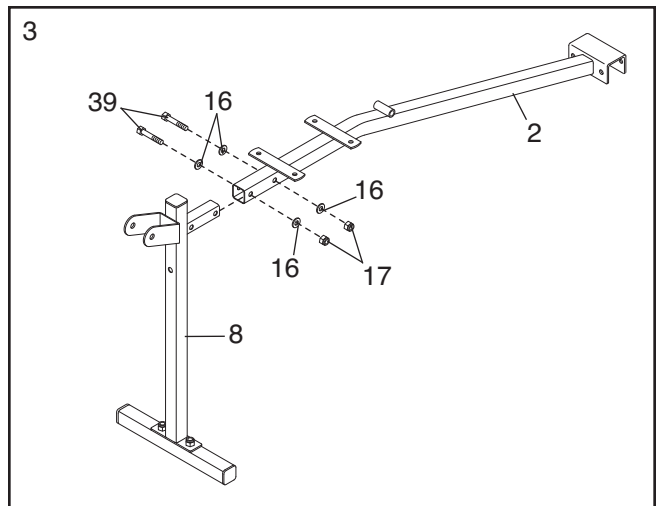

- Attach the Frame (2) to the Crossbar (3) with two M8 x 55mm Bolts (18) and two M8 Nylon Locknuts (17).

Tighten the M8 Nylon Locknuts (17) used in steps 1–4.

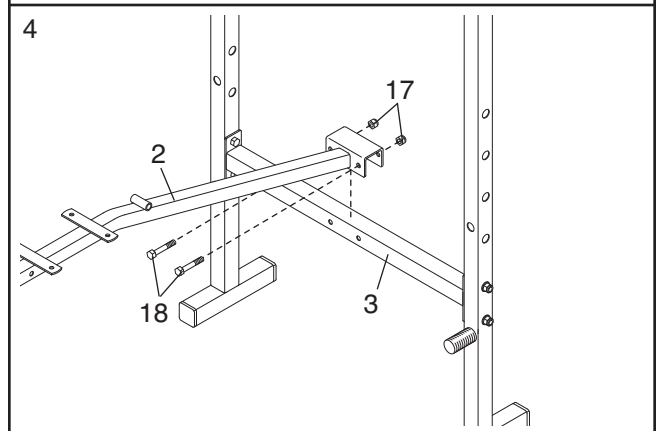

- Lubricate the M10 x 63mm Bolt (32) with grease. Attach the Leg Lever (4) to the Front Leg (8) with the Bolt and an M10 Nylon Locknut (33). **Do not overtighten the Locknut; the Leg Lever must be able to pivot easily.**

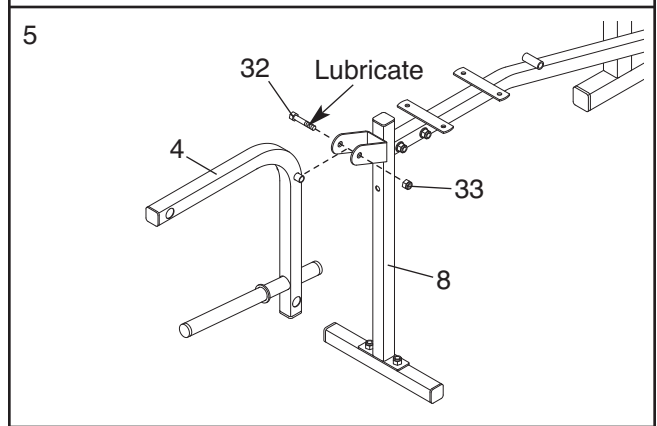

- Insert a Pad Tube (10) into a hole in the Leg Lever (4). Slide two Foam Pads (23) onto the Pad Tube.

Repeat this step with the other Pad Tube (10).

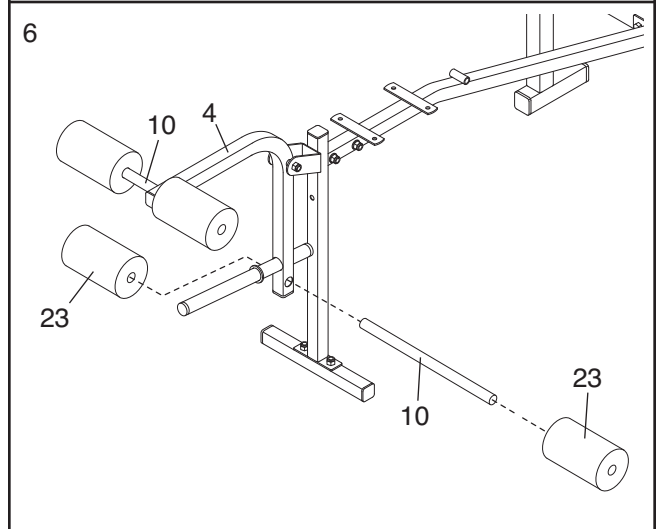

- Attach the Backrest Tubes (5) to the Backrest (6) with four M6 x 38mm Screws (30) and four M6 Washers (26). **Do not tighten the Screws yet.**

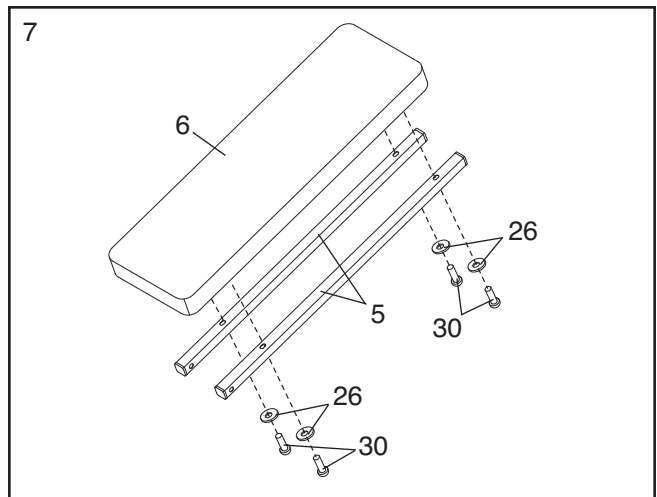

- Insert the Support Rod (7) through a set of holes in the Uprights (1). Rotate the Support Rod to the locked position, with the locking pin wrapped around the Upright.

Lubricate the M10 x 137mm Bolt (36) with grease. Attach the Backrest Tubes (5) to the welded tube on the Frame (2) with the Bolt, two M10 Washers (34), and an M10 Nylon Locknut (33). **Do not overtighten the Locknuts; the Backrest Tubes must be able to pivot easily.**

Tighten the M6 x 38mm Screws (30) used in step 7.

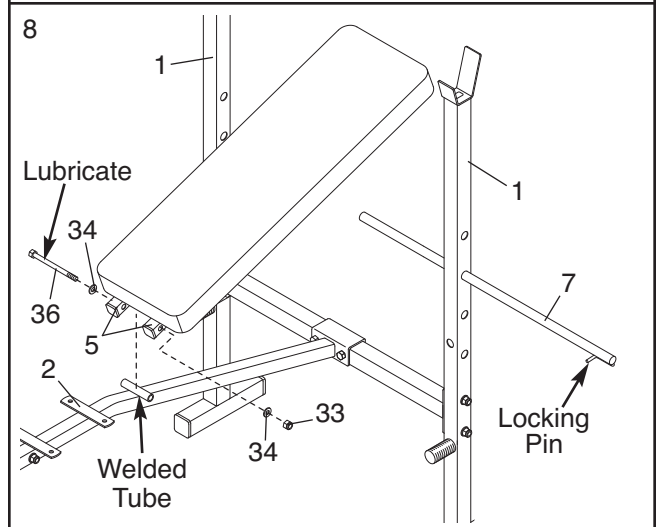

- Attach the Seat (11) to the Frame (2) with four M6 x 16mm Screws (29).

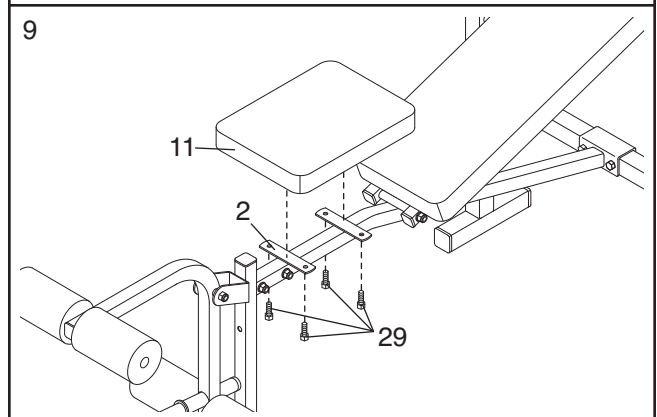

- Slide a Weight Stop (28) onto the weight tube on a Fly Arm (25).

Assemble the other Fly Arm (not shown) in the same manner.

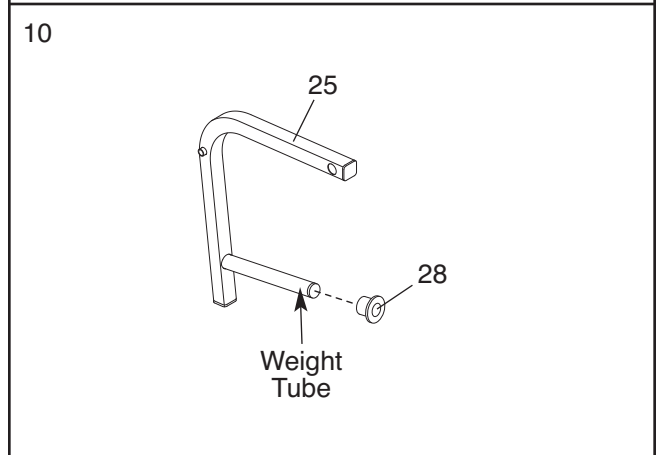

11. Attach a Fly Arm (25) to an Upright (1) with an M10 x 120mm Bolt (19) and an M10 Nylon Locknut (33). Make sure the Fly Arm is on the outside of the Fly Arm Stop (15). **Do not over-tighten the Locknut; the Fly Arm must be able to pivot easily.**

Attach the other Fly Arm (25) to the other Upright (1) in the same manner.

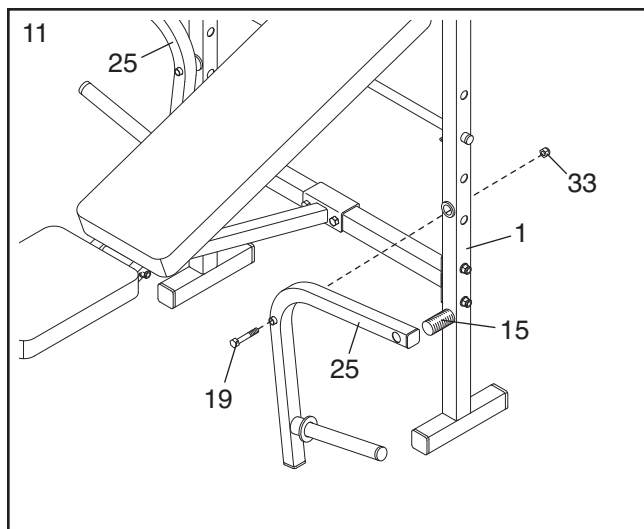

12. Insert the Arm Pad Tube (12) into the indicated hole in a Fly Arm (25) as shown.

Push a Foam Pad (23) onto the Arm Pad Tube (12); the Foam Pad will hold the Arm Pad Tube in place.

Repeat this step with the other Fly Arm (not shown).

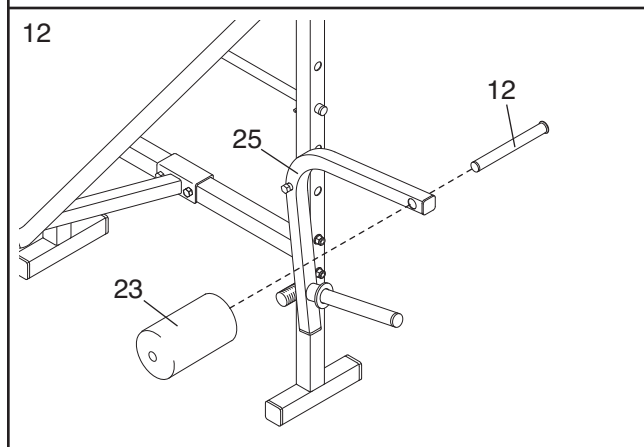

13. Insert the Inner Bar (43) into the Outer Bar (40) and align the indicated holes. Using a hammer, tap the two Roll Pins (41) into the holes until they are flush with the Outer Bar.

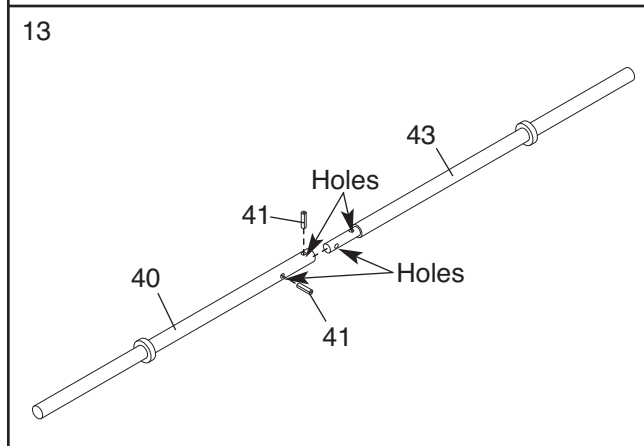

14. Attach the Curl Pad (45) to the Curl Post (27) with two M6 x 16mm Screws (29).

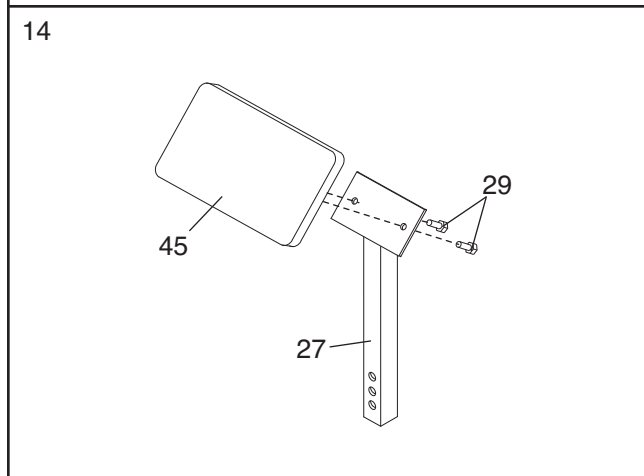

15. **Make sure that all parts are properly tightened before the weight bench is used. The use of all remaining parts will be explained in ADJUSTMENTS starting on the next page.**

ADJUSTMENTS

The steps below explain how the weight bench can be adjusted. See the accompanying exercise guide to see the correct form for several exercises.

Make sure all parts are properly tightened each time the weight bench is used. Replace any worn parts immediately. The weight bench can be cleaned with a damp cloth and a mild, non-abrasive detergent. Do not use solvents.

ADJUSTING THE BACKREST

The Backrest (6) can be used in a declined position, a level position, or three inclined positions. To use the Backrest in a declined position, remove the Support Rod (7) and lay the Backrest on the Crossbar (3).

To use the Backrest (6) in a level position or an inclined position, insert the Support Rod (7) through a set of holes in the Uprights (1). Rotate the Support Rod to the locked position, so the locking pin is wrapped around the Upright. Rest the Backrest on the Support Rod.

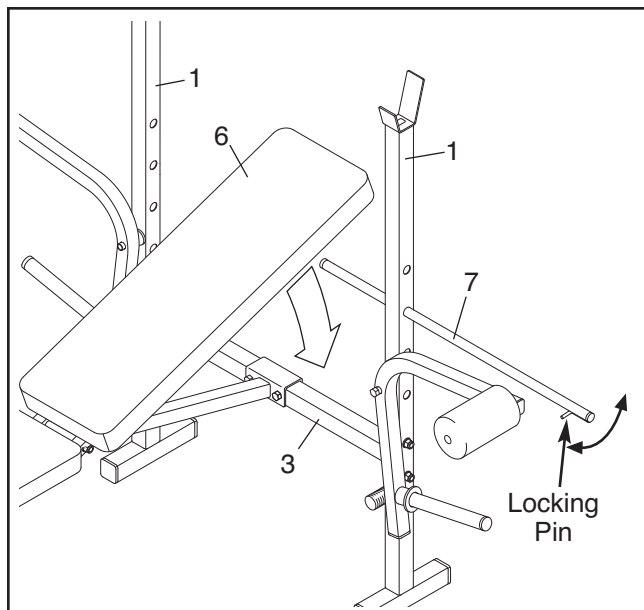

ATTACHING WEIGHTS

To use the Leg Lever (4), slide the desired weights onto the weight tube on the Leg Lever. **Do not place more than 50 pounds on the Leg Lever.**

To use the Fly Arms (25), make sure there is a Weight Stop (28) on each weight tube. Next, slide the desired amount of weight onto the weight tubes. **Do not place more than 30 pounds on each Arm.**

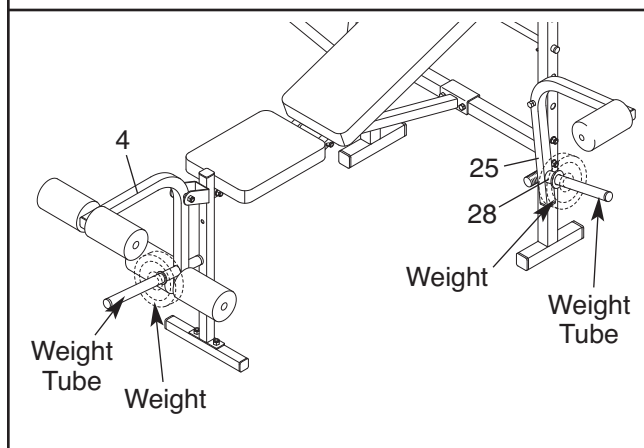

⚠ WARNING: When using the Leg Lever (4), place a barbell with the same amount of weight on the weight rests to balance the bench.

ATTACHING WEIGHTS TO THE BARBELL

Slide an equal amount of Weight (44, 38) onto each end of the barbell. Slide the two Lock Collars (42) against the Weights, and tighten them fully.

⚠ WARNING: Always secure the Weights (44, 38) on the barbell with the Lock Collars (42). Never use the barbell with more than 100 pounds.

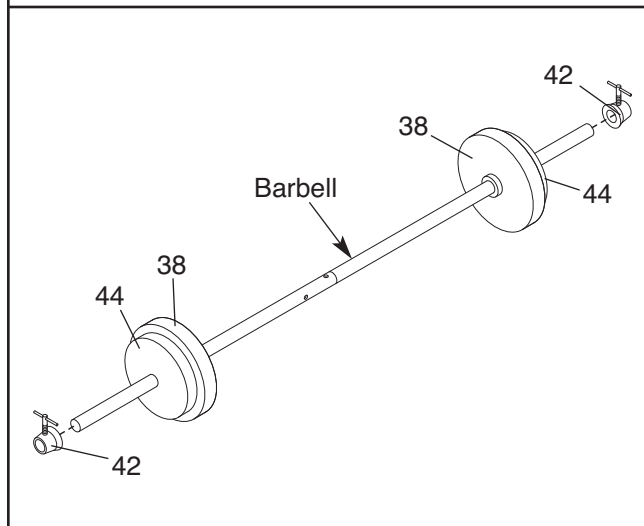

ATTACHING THE CURL PAD

For some exercises, the Curl Pad (45) needs to be attached to the weight bench. To do this, remove the 30mm Square Inner Cap (22) from the Front Leg (8). Insert the Curl Post (27) into the Front Leg and align an adjustment hole in the Curl Post with the adjustment hole in the Front Leg. Secure the Curl Post with the Curl Knob (31).

Note: When the Curl Pad (45) is not being used, store it away from the weight bench, and insert the 30mm Square Inner Cap (22) into the Front Leg (8).

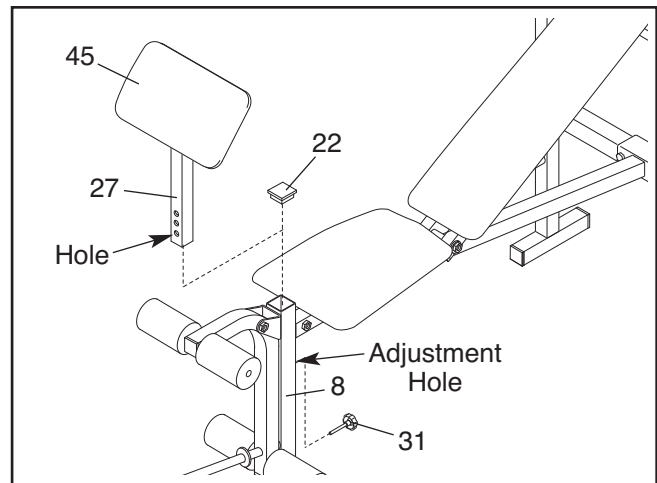

EXERCISE GUIDELINES

THE FOUR BASIC TYPES OF WORKOUTS

Muscle Building

To increase the size and strength of your muscles, push them close to their maximum capacity. Your muscles will continually adapt and grow as you progressively increase the intensity of your exercise. You can adjust the intensity level of an individual exercise in two ways:

- by changing the amount of resistance used
- by changing the number of repetitions or sets performed. (A “repetition” is one complete cycle of an exercise, such as one sit-up. A “set” is a series of repetitions.)

The proper amount of resistance for each exercise depends upon the individual user. You must gauge your limits and select the amount of resistance that is right for you. Begin with 3 sets of 8 repetitions for each exercise you perform. Rest for 3 minutes after each set. When you can complete 3 sets of 12 repetitions without difficulty, increase the amount of resistance.

Toning

You can tone your muscles by pushing them to a moderate percentage of their capacity. Select a moderate amount of resistance and increase the number of repetitions in each set. Complete as many sets of 15 to 20 repetitions as possible without discomfort. Rest for 1 minute after each set. Work your muscles by completing more sets rather than by using high amounts of resistance.

Weight Loss

To lose weight, use a low amount of resistance and increase the number of repetitions in each set. Exercise for 20 to 30 minutes, resting for a maximum of 30 seconds between sets.

Cross Training

Cross training is an efficient way to get a complete and well-balanced fitness program. An example of a balanced program is:

- Plan strength training workouts on Monday, Wednesday, and Friday.
- Plan 20 to 30 minutes of aerobic exercise, such as running on a treadmill or riding on an exercise cycle or an elliptical exerciser, on Tuesday and Thursday.
- Rest from both strength training and aerobic exercise for at least one full day each week to give your body time to regenerate.

The combination of strength training and aerobic exercise will reshape and strengthen your body, plus develop your heart and lungs.

PERSONALIZING YOUR EXERCISE PROGRAM

Determining the exact length of time for each workout, as well as the number of repetitions or sets completed, is an individual matter. It is important to avoid overdoing it during the first few months of your exercise program. You should progress at your own pace and be sensitive to your body’s signals. If you experience pain or dizziness at any time while exercising, stop immediately and begin cooling down. Find out what is wrong before continuing. Remember that adequate rest and a proper diet are important factors in any exercise program.

WARMING UP

Begin each workout with 5 to 10 minutes of stretching and light exercise to warm up. Warming up prepares your body for more strenuous exercise by increasing circulation, raising your body temperature and delivering more oxygen to your muscles.

WORKING OUT

Each workout should include 6 to 10 different exercises. Select exercises for every major muscle group, emphasizing areas that you want to develop most. To give balance and variety to your workouts, vary the exercises from session to session. Schedule your workouts for the time of day when your energy level is the highest. Each workout should be followed by at least one day of rest. Once you find the schedule that is right for you, stick with it.

EXERCISE FORM

Maintaining proper form is an essential part of an effective exercise program. This requires moving through the full range of motion for each exercise, and moving only the appropriate parts of the body. Exercising in an uncontrolled manner will leave you feeling exhausted. On the exercise guide accompanying this manual you will find photographs showing the correct form for several exercises, and a list of the muscles affected. See the muscle chart on the next page to find the names of the muscles.

The repetitions in each set should be performed smoothly and without pausing. The exertion stage of each repetition should last about half as long as the return stage. Proper breathing is important. Exhale during the exertion stage of each repetition and inhale during the return stroke. Never hold your breath.

Rest for a short period of time after each set. The ideal resting periods are:

- Rest for three minutes after each set for a muscle building workout.
- Rest for one minute after each set for a toning workout.
- Rest for 30 seconds after each set for a weight loss workout.

Plan to spend the first couple of weeks familiarizing yourself with the equipment and learning the proper form for each exercise.

COOLING DOWN

End each workout with 5 to 10 minutes of stretching. Include stretches for both your arms and legs. Move slowly as you stretch and do not bounce. Ease into each stretch gradually and go only as far as you can without strain. Stretching at the end of each workout is an effective way to increase flexibility.

STAYING MOTIVATED

For motivation, keep a record of each workout. List the date, the exercises performed, the resistance used, and the numbers of sets and repetitions completed. Record your weight and key body measurements at the end of every month. Remember, the key to achieving the greatest results is to make exercise a regular and enjoyable part of your everyday life.

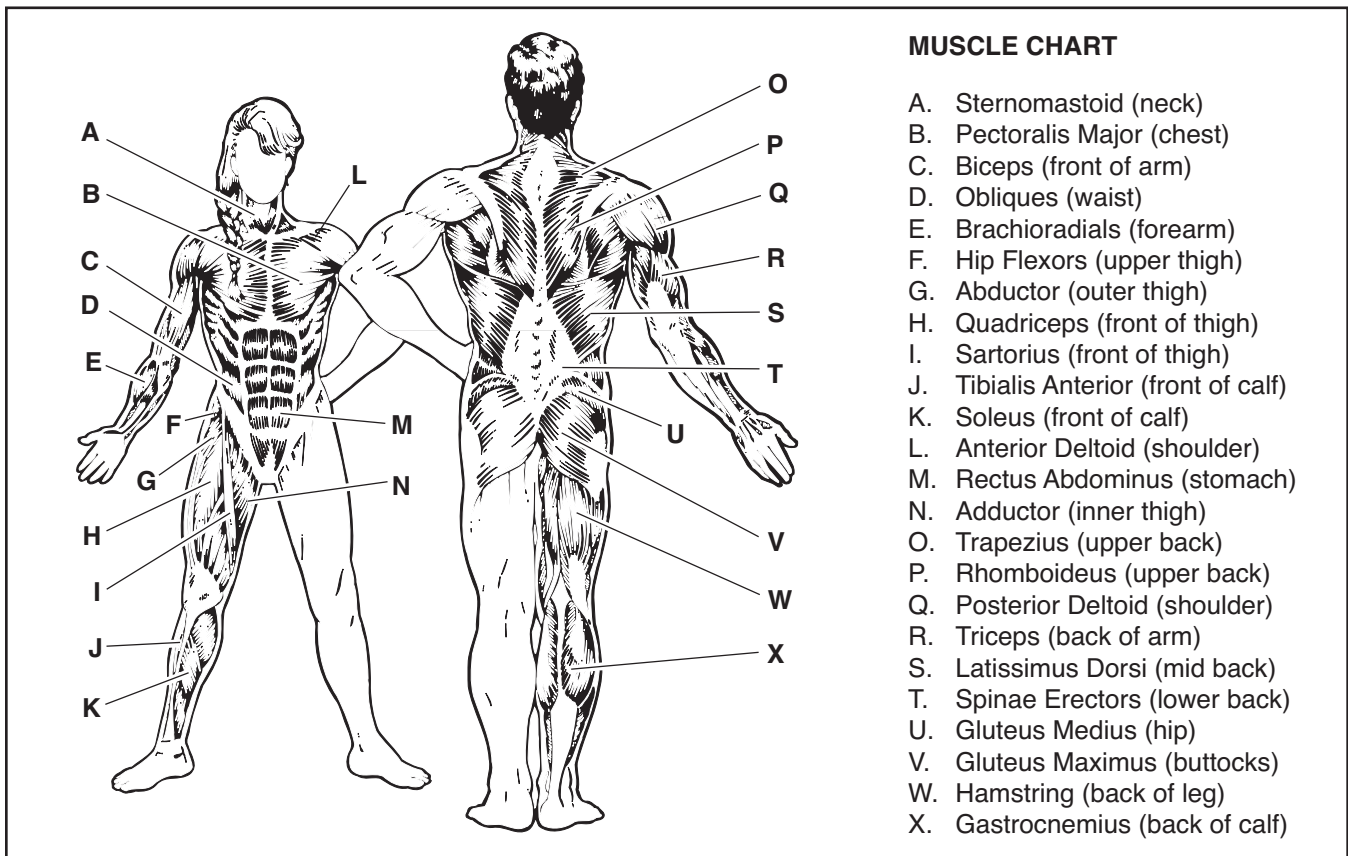

PART IDENTIFICATION CHART

This chart is provided to help you identify the small parts used in assembly. The number in parenthesis below each part refers to the key number of the part from the PART LIST in the center of this manual. **Important:** Some parts may have been pre-assembled for shipping purposes. If a part is missing, call toll-free 1-877-992-5999.

A long bolt with a hexagonal head and a hexagonal base.		
M10 x 137mm Bolt (36)		
A long bolt with a hexagonal head and a hexagonal base.		
M10 x 120mm Bolt (19)		
A medium-length bolt with a hexagonal head and a hexagonal base.		
M10 x 63mm Bolt (32)		
A medium-length bolt with a hexagonal head and a hexagonal base.		
M8 x 55mm Bolt (18)		
A medium-length bolt with a hexagonal head and a hexagonal base.		
M8 x 43mm Bolt (39)		
A carriage bolt with a hexagonal head and a hexagonal base.		
M8 x 42mm Carriage Bolt (37)		
A screw with a flat head and a hexagonal base.		
M6 x 38mm Screw (30)		
A short screw with a flat head and a hexagonal base.		
M6 x 16mm Screw (29)		
	A hexagonal nylon locknut with a hexagonal base.	
	M8 Nylon Locknut (17)	
		A hexagonal nylon locknut with a hexagonal base.
		M10 Nylon Locknut (33)
		A flat washer with a central hole.
		M6 Washer (26)
		A flat washer with a central hole.
		M8 Washer (16)
		A flat washer with a central hole.
		M10 Washer (34)

PART LIST—Model No. 831.15679.0

R0705A

Key No.	Qty.	Description	Key No.	Qty.	Description
1	2	Upright	25	2	Fly Arm
2	1	Frame	26	4	M6 Washer
3	1	Crossbar	27	1	Curl Post
4	1	Leg Lever	28	2	Weight Stop
5	2	Backrest Tube	29	6	M6 x 16mm Screw
6	1	Backrest	30	4	M6 x 38mm Screw
7	1	Support Rod	31	1	Curl Knob
8	1	Front Leg	32	1	M10 x 63mm Bolt
9	8	19mm Round Inner Cap	33	4	M10 Nylon Locknut
10	2	Pad Tube	34	2	M10 Washer
11	1	Seat	35	4	25mm Square Inner Cap
12	2	Arm Pad Tube	36	1	M10 x 137mm Bolt
13	1	Stabilizer	37	2	M8 x 42mm Carriage Bolt
14	4	Plastic Bushing	38	4	15-pound Weight
15	2	Fly Arm Stop	39	2	M8 x 43mm Bolt
16	8	M8 Washer	40	1	Outer Bar
17	10	M8 Nylon Locknut	41	2	Roll Pin
18	6	M8 x 55mm Bolt	42	2	Lock Collar
19	2	M10 x 120mm Bolt	43	1	Inner Bar
20	1	25mm Round Angled Cap	44	2	10-pound Weight
21	4	38mm Square Inner Cap	45	1	Curl Pad
22	9	30mm Square Inner Cap	#	1	User's Manual
23	6	Foam Pad	#	1	Exercise Guide
24	5	25mm Round Inner Cap	#	1	Grease Pack

Note: “#” indicates a non-illustrated part. Specifications are subject to change without notice. See the back cover of this manual for information about ordering replacement parts. If a part is missing, call toll-free 1-877-992-5999.

EXPLODED DRAWING—Model No. 831.15679.0

R0705A

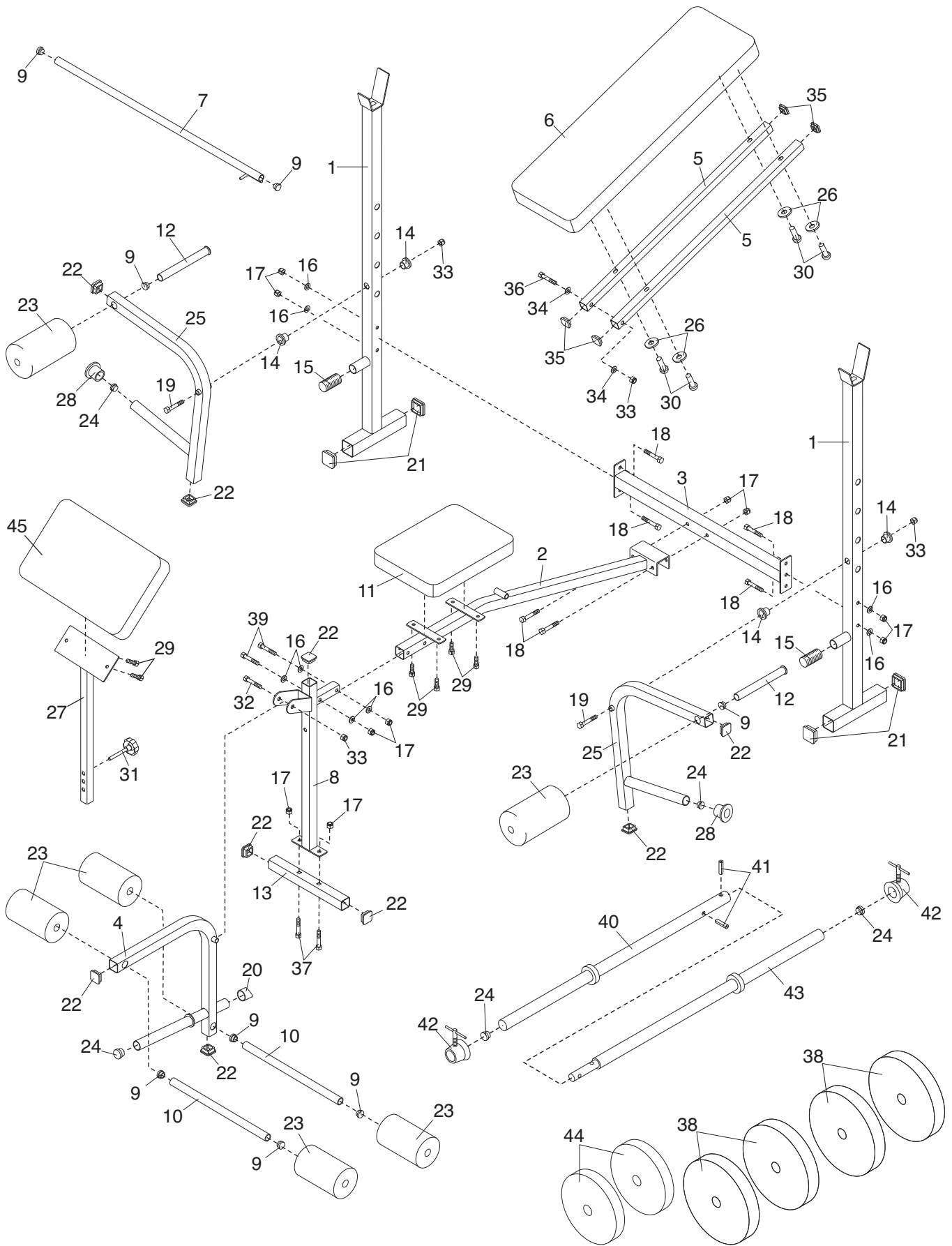

Get it fixed, at your home or ours!

Your Home

For repair – **in your home** – of **all** major brand appliances, lawn and garden equipment, or heating and cooling systems, **no matter who made it, no matter who sold it!**

For the replacement parts, accessories, and user's manuals that you need to do-it-yourself.

For Sears professional installation of home appliances and items like garage door openers and water heaters.

1-800-4-MY-HOME®

(1-800-469-4663)

www.sears.com

Anytime, day or night

(U.S.A. and Canada)

www.sears.ca

Our Home

For repair of carry-in products like vacuums, lawn equipment, and electronics, call or go on-line for the location of your nearest **Sears Parts and Repair Center.**

1-800-488-1222 Anytime, day or night (U.S.A. only)

www.sears.com

To purchase a protection agreement (U.S.A.) or maintenance agreement (Canada) on a product serviced by Sears:

1-800-827-6655 (U.S.A.)

1-800-361-6665 (Canada)

Para pedir servicio de reparación a domicilio, y para ordenar piezas:

1-888-SU-HOGARSM (1-888-784-6427)

SEARS

® Registered Trademark / ™ Trademark / ™ Service Mark of Sears, Roebuck and Co.
® Marca Registrada / ™ Marca de Fábrica / ™ Marca de Servicio de Sears, Roebuck and Co.

FULL 90-DAY WARRANTY

For 90 days from the date of purchase, if failure occurs due to defect in material or workmanship in this WEIGHT BENCH EXERCISER, contact the nearest Sears Service Center throughout the United States and Sears will repair or replace the WEIGHT BENCH EXERCISER, free of charge.

This warranty does not apply when the WEIGHT BENCH EXERCISER is used commercially or for rental purposes.

This warranty gives you specific legal rights, and you may also have other rights which vary from state to state.

Sears, Roebuck and Co., Dept 817WA, Hoffman Estates, IL 60179