

# WEIDER<sup>®</sup> PRO 4250

Model No. WEMSSY2915.0

Serial No. \_\_\_\_\_

Write the serial number in the space above for reference.

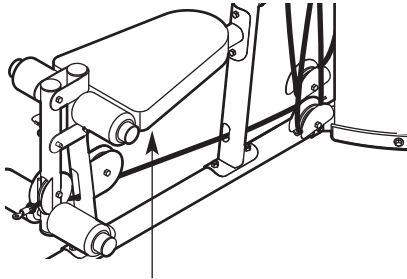

Serial Number Decal (under seat)

## USER'S MANUAL

### QUESTIONS?

As a manufacturer, we are committed to providing complete customer satisfaction. If you have questions, or if there are missing parts, please call the telephone number on the warranty card accompanying this manual.

**Importer:**

Comercializadora México  
Americana, S. de R.L. de C.V.  
Av. Nextengo No. 78  
Col. Santa Cruz Acayucan  
Del. Azcapotzalco  
México D.F., C.P. 02770  
R.F.C. CMA-910911-9L0  
Tel. 5899 12 00

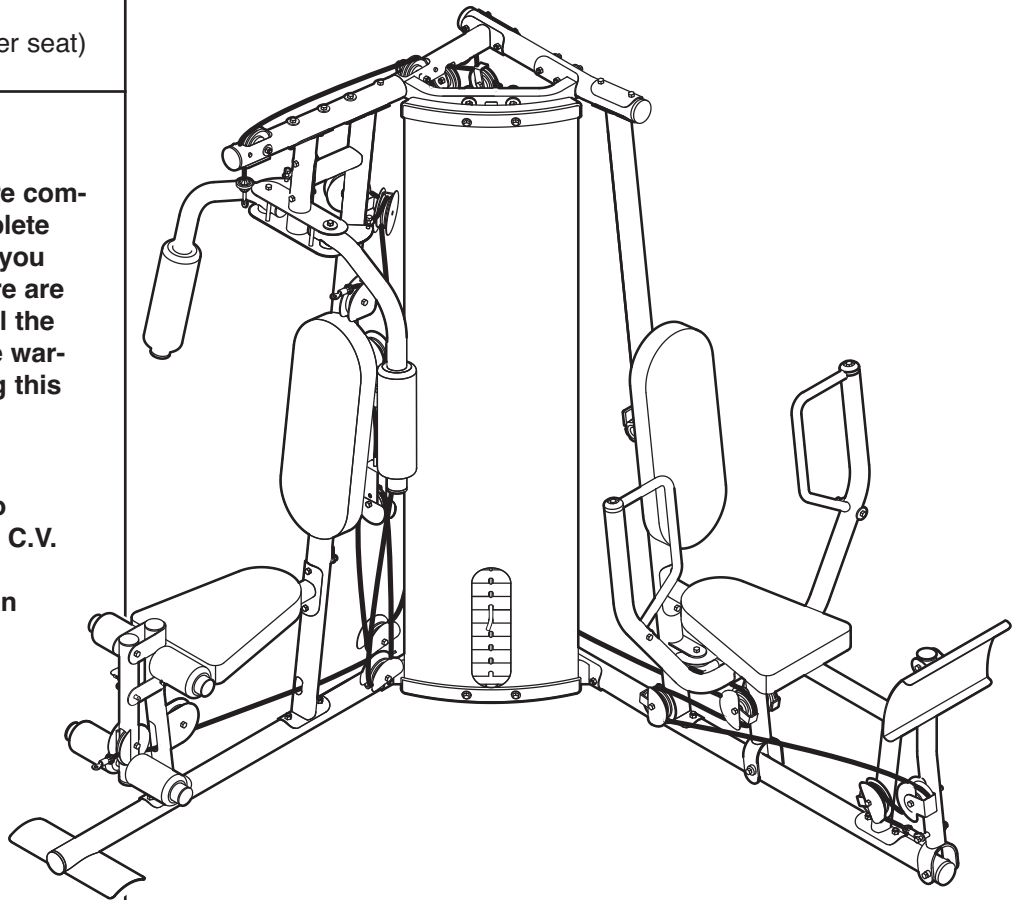

### CAUTION

Read all precautions and instructions in this manual before using this equipment. Save this manual for future reference.



Visit our website at

[www.weiderfitness.com](http://www.weiderfitness.com)

new products, prizes,  
fitness tips, and much more!

# TABLE OF CONTENTS

WARNING DECAL PLACEMENT .....	2
IMPORTANT PRECAUTIONS .....	3
BEFORE YOU BEGIN .....	4
ASSEMBLY .....	5
ADJUSTMENTS .....	23
WEIGHT RESISTANCE CHART .....	25
CABLE DIAGRAMS .....	26
MAINTENANCE .....	28
EXERCISE GUIDELINES .....	29
ORDERING REPLACEMENT PARTS .....	Back Cover

Note: A PART IDENTIFICATION CHART and a PART LIST/EXPLODED DRAWING are attached in the center of this manual. Remove the PART IDENTIFICATION CHART and PART LIST/EXPLODED DRAWING before beginning assembly.

## WARNING DECAL PLACEMENT

The decal shown here has been placed on the weight system in the locations shown. If a decal is missing or illegible, call the telephone number on the warranty card accompanying this manual and order a free replacement decal. Apply the decal in the location shown.

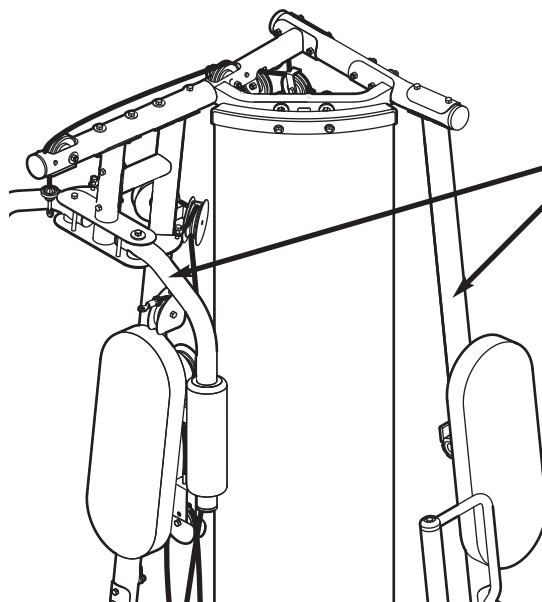

**⚠ WARNING**

- Misuse of this machine may result in serious injury.
- Read user's manual prior to use and follow all warnings and instructions.
- Do not allow children on or around machine.
- Keep body, clothing, and hair free and clear of all moving parts.
- Replace label if damaged, illegible, or removed.

# IMPORTANT PRECAUTIONS

**⚠ WARNING:** To reduce the risk of serious injury, read the following important precautions before using the weight system.

1. Read all instructions in this manual and all warnings on the weight system before using the weight system. Use the weight system only as described in this manual.
2. It is the responsibility of the owner to ensure that all users of the weight system are adequately informed of all precautions.
3. The weight system is intended for home use only. Do not use the weight system in any commercial, rental, or institutional setting.
4. Keep the weight system indoors, away from moisture and dust. Place the weight system on a level surface, with a mat beneath it to protect the floor or carpet. Make sure that there is enough clearance around the weight system to mount, dismount, and use the weight system.
5. Inspect and properly tighten all parts regularly. Replace any worn parts immediately.
6. Keep children under 12 and pets away from the weight system at all times.
7. Always wear athletic shoes for foot protection while exercising.
8. Keep hands and feet away from moving parts.
9. The weight system is designed to support a maximum user weight of 135 kg (300 lbs.).
10. The weight system is designed to be used only with the included weight. Do not use the weight system with dumbbells or any other type of weight to increase the resistance.
11. Make sure that the cables remain on the pulleys at all times. If the cables bind as you are exercising, stop immediately and make sure that the cables are on the pulleys. Replace all cables at least every two years.
12. Always secure the weight stack with the lock pin and lock after exercising to prevent unauthorized use of the weight system (see **LOCKING THE WEIGHT STACK** on page 24).
13. Always stand on the foot plate when performing an exercise that could cause the weight system to tip.
14. Never release the arms, leg lever, lat bar, leg press, ab strap, or handle while weights are raised. The weights will fall with great force.
15. *Always disconnect the lat bar from the weight system when performing an exercise that does not use the lat bar.*
16. If you feel pain or dizziness at any time while exercising, stop immediately and begin cooling down.

**⚠ WARNING:** Before beginning this or any exercise program, consult your physician. This is especially important for persons over the age of 35 or persons with pre-existing health problems. Read all instructions before using. ICON assumes no responsibility for personal injury or property damage sustained by or through the use of this product.

# BEFORE YOU BEGIN

Thank you for selecting the versatile WEIDER® PRO 4250 weight system. The weight system offers an impressive array of weight stations designed to develop every major muscle group of the body. Whether your goal is to tone your body, build dramatic muscle size and strength, or improve your cardiovascular system, the weight system will help you to achieve the specific results you want.

**For your benefit, read this manual carefully before using the weight system.** If you have questions after

reading this manual, see the front cover of this manual. To help us assist you, please note the product model number and serial number before calling. The model number is WEMSSY2915.0. The serial number can be found on a decal attached to the weight system (see the front cover of this manual for the location of the decal).

Before reading further, please review the drawing below and familiarize yourself with the parts that are labeled.

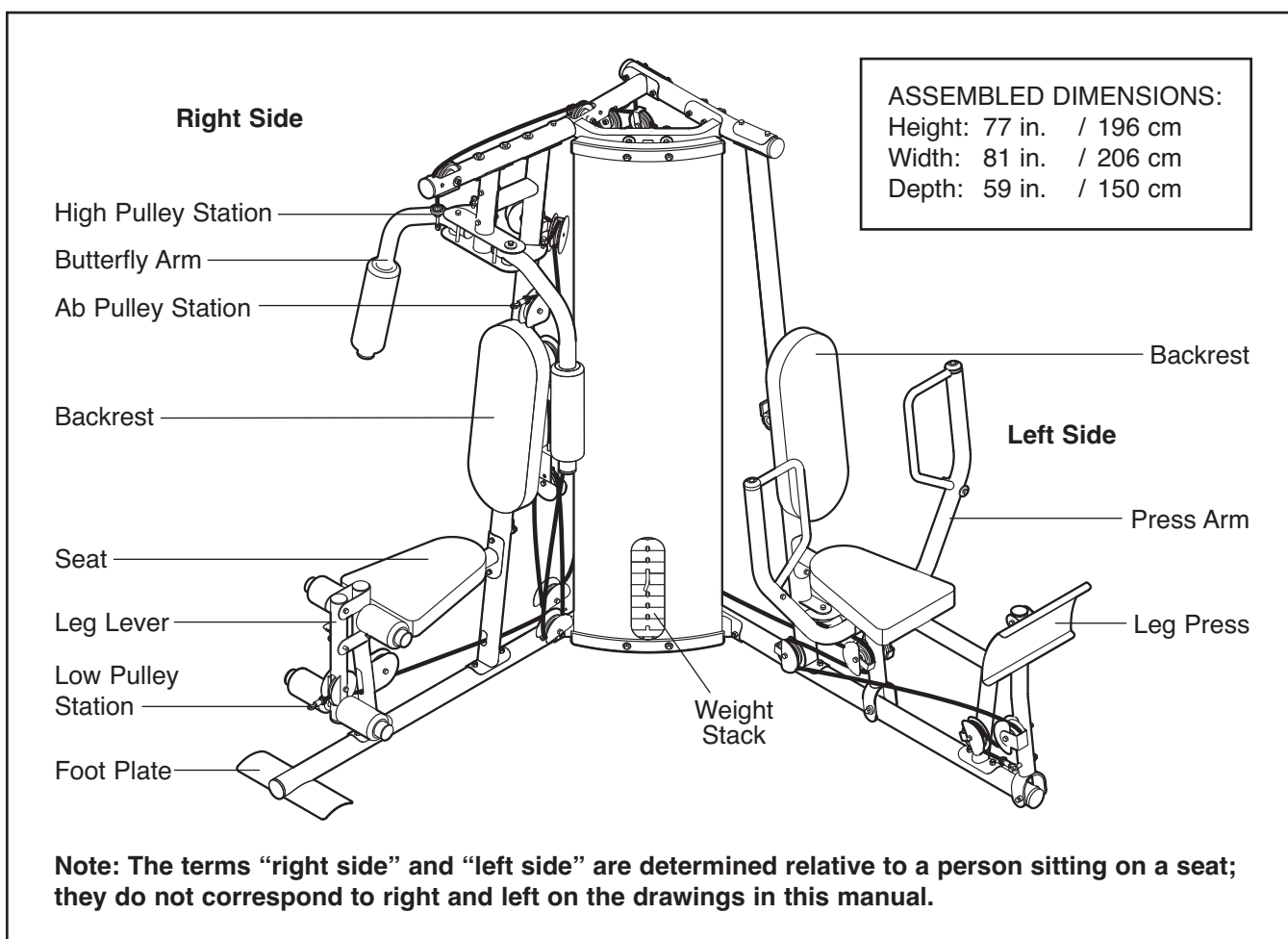

# ASSEMBLY

## MAKE ASSEMBLY EASIER

Everything in this manual is designed to ensure that the weight system can be assembled successfully by anyone. **Before beginning assembly, make sure to read the information on this page. This brief introduction will save you much more time than it takes to read it.**

## ASSEMBLY REQUIRES TWO PERSONS

For your convenience and safety, assemble the weight system with the help of another person.

## SET ASIDE ENOUGH TIME

Due to the many features of the weight system, the assembly process will require several hours. By setting aside plenty of time and by deciding to make the task enjoyable, assembly will go smoothly. You may want to assemble the weight system over a couple of evenings.



## SELECT A LOCATION

Because of its weight and size, the weight system should be assembled in the location where it will be used. Make sure that there is enough room to walk around the weight system as you assemble it.

## HOW TO UNPACK THE BOX

To make assembly as easy as possible, we have divided the assembly process into four stages. The parts needed for each stage are found in individual bags. **Important: Wait until you begin each stage to open the parts bag for that stage.** Place all parts of the weight system in a cleared area and remove the packing materials. Do not dispose of the packing materials until assembly is completed.

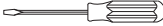
## MAKE SURE YOU HAVE THE FOLLOWING TOOLS:

- Two adjustable wrenches 
- One standard screwdriver 
- One phillips screwdriver 
- One rubber mallet 
- You will also need grease or petroleum jelly, a small amount of soapy water, and clear tape or masking tape.

Note: Assembly will be more convenient if you have a socket set, a set of open-end or closed-end wrenches, or a set of ratchet wrenches.

## HOW TO IDENTIFY PARTS

To help you identify the small parts used in assembly, we have included a **PART IDENTIFICATION CHART** in the center of this manual. Place the chart on the floor and use it to easily identify parts during each assembly step. **Note: Some small parts may have been pre-attached. If a part is not in the parts bag, check to see if it has been pre-attached.**

## HOW TO ORIENT PARTS

As you assemble the weight system, make sure all parts are oriented exactly as shown in the drawings.

## TIGHTENING PARTS

Tighten all parts as you assemble them, unless instructed to do otherwise.

## QUESTIONS?

If you have questions after reading the assembly instructions, see the front cover of this manual.

## THE FOUR STAGES OF THE ASSEMBLY PROCESS

**Frame Assembly**—You will begin by assembling the base and the uprights that form the skeleton of the weight system.

**Arm Assembly**—During this stage you will assemble the arms and the leg lever.

**Cable Assembly**—During this stage you will attach the cables and pulleys that connect the arms to the weights.

**Seat Assembly**—During the final stage you will assemble the seats and the backrests.

# Frame Assembly

1. Before beginning assembly, make sure you understand the information in the box on page 5. See the **PART IDENTIFICATION CHART** in the center of this manual for help identifying small parts.

Insert four M8 x 75mm Carriage Bolts (69) up through the Right Base (1). **Note: It may be helpful to place a piece of tape over each bolt head to hold it in place.**

2. Insert four M8 x 75mm Carriage Bolts (69) up through the Left Base (25). **Note: It may be helpful to place a piece of tape over each bolt head to hold it in place.**

3. Attach the Right Base (1) to the Left Base (25) with two M8 x 78mm Bolts (82), two M8 Washers (98), and two M8 Nylon Locknuts (91). **Do not tighten the Locknuts yet.**

4. Attach the Center Base (52) to the Right Base (1) with two M8 x 78mm Bolts (82), two M8 Washers (98), and an M8 Nylon Locknut (91). **Do not tighten the Bolts yet.**

**Attach the Center Base (52) to the Left Base (25) in the same manner.**

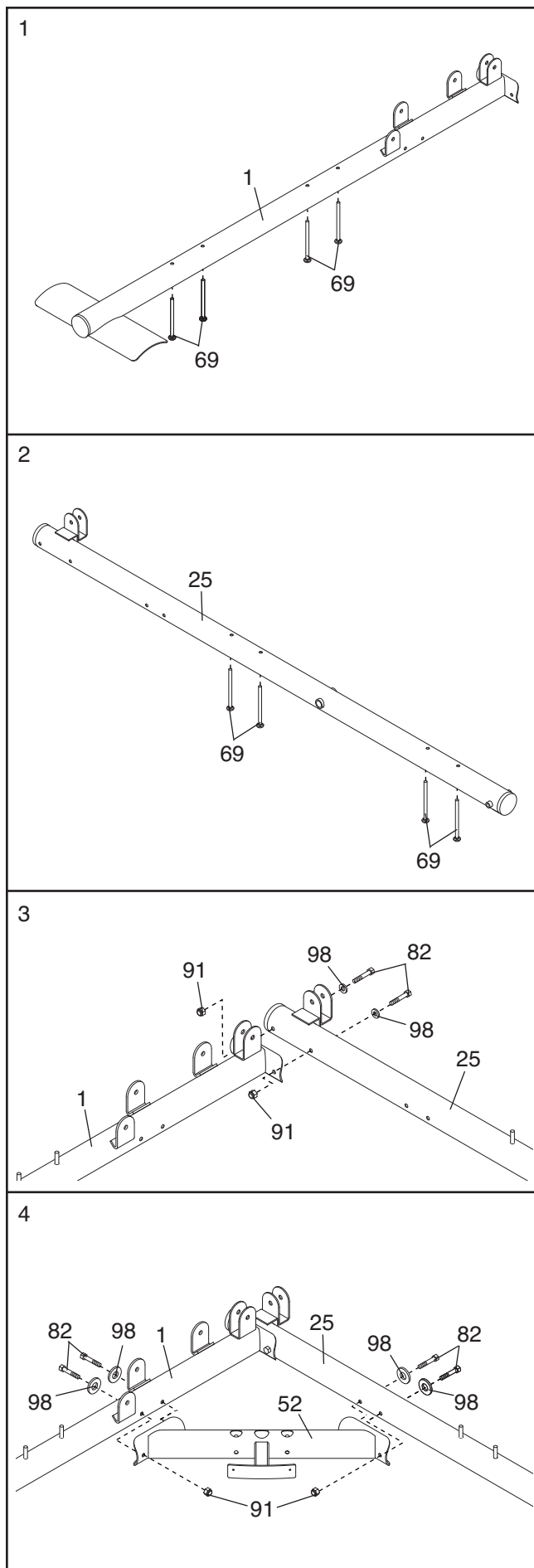

5. **See drawing A.** Attach the Right Upright (2) to the Right Base (1) with the two indicated M8 x 75mm Carriage Bolts (69) and two M8 Nylon Locknuts (91). **Do not tighten the Locknuts yet.**

**See drawing B.** Attach the Left Upright (26) to the Left Base (25) with the two indicated M8 x 75mm Carriage Bolts (69) and two M8 Nylon Locknuts (91). **Do not tighten the Locknuts yet.**

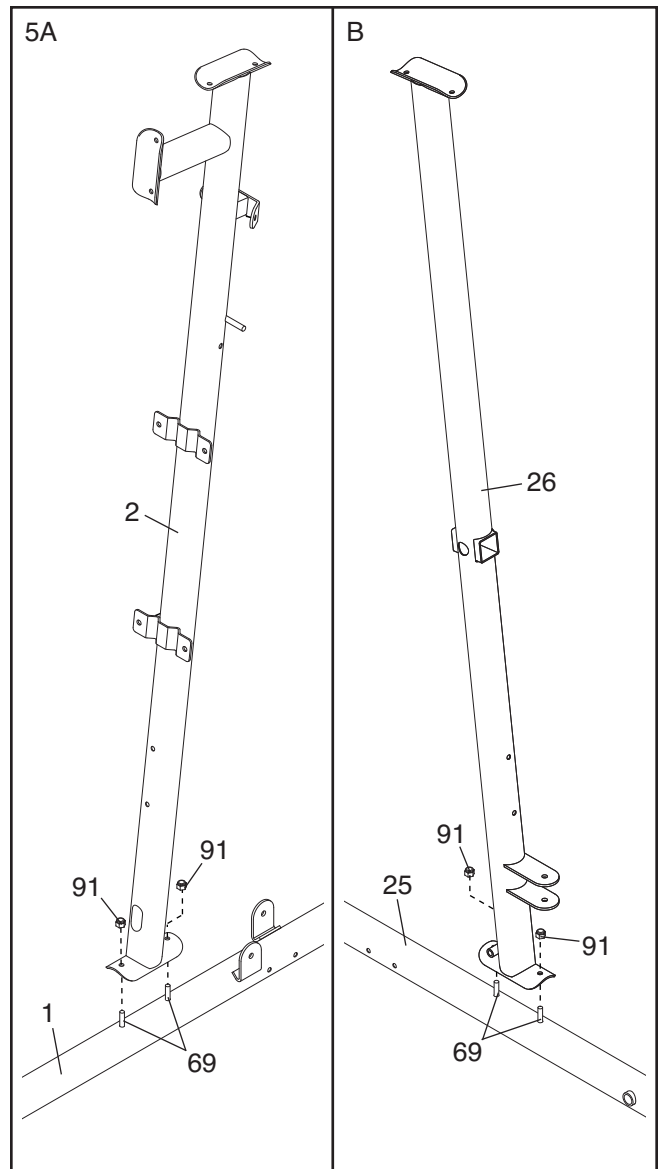

6. Attach the Right Seat Frame (3) to the Right Base (1) with the two indicated M8 x 75mm Carriage Bolts (69) and two M8 Nylon Locknuts (91). **Do not tighten the Locknuts yet.**

Attach the Right Seat Frame (3) to the Right Upright (2) with an M8 x 78mm Bolt (82), an M8 x 96mm Bolt (83), an M8 Washer (98), and an M8 Nylon Locknut (91). **Do not tighten the Locknut yet.**

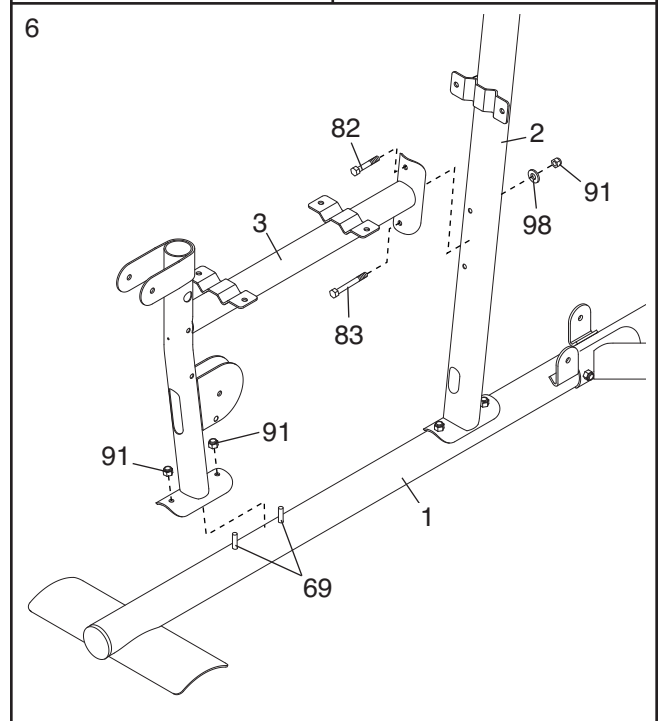

7. Attach the Left Seat Frame (27) to the Left Base (25) with the two indicated M8 x 75mm Carriage Bolts (69) and two M8 Nylon Locknuts (91). **Do not tighten the Locknuts yet.**

Attach the Left Seat Frame (27) to the Left Upright (26) with two M8 x 78mm Bolts (82), two M8 Washers (98), and two M8 Nylon Locknuts (91). **Do not tighten the Locknuts yet.**

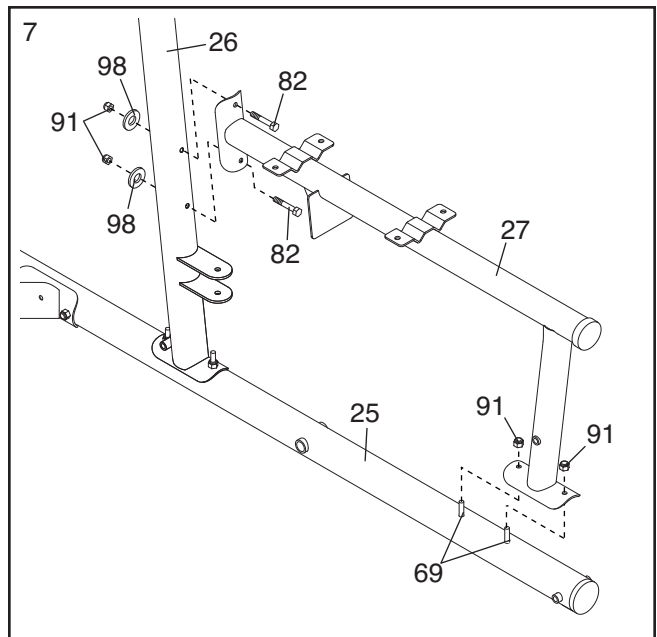

8. Orient the Weight Guides (44) with the indicated holes closer to the bottom. Attach the Weight Guides inside of the Center Base (52) with two M8 x 78mm Bolts (82), four M8 Washers (98), and two M8 Nylon Locknuts (91).

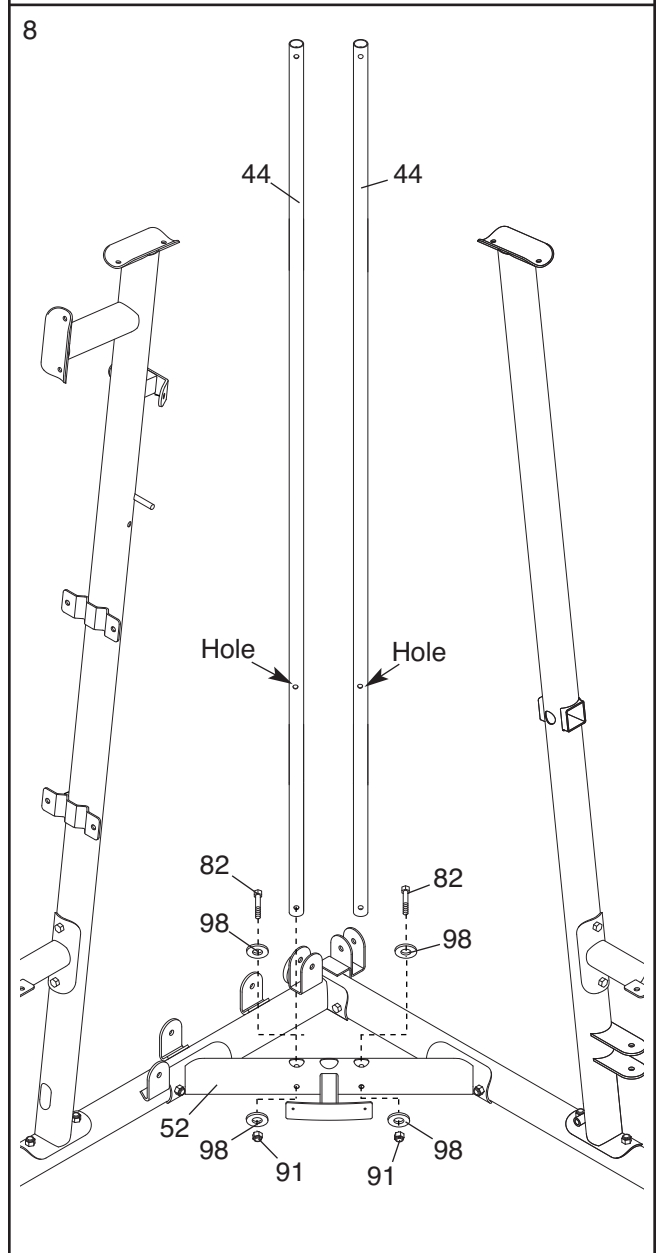



- Slide two Weight Bumpers (45) onto the Weight Guides (44). Slide the eight Weights (55), with the pin holes on the indicated side, onto the Weight Guides.

Press the Weight Tube Bumper (46) into the Weight Tube (47). Insert the Weight Tube into the stack of Weights (55). **Make sure the pin on the Weight Tube sits in the groove in the top Weight.**

Grease the indicated holes in the Top Weight (56) with an included grease pack. Slide the Top Weight onto the Weight Guides (44).

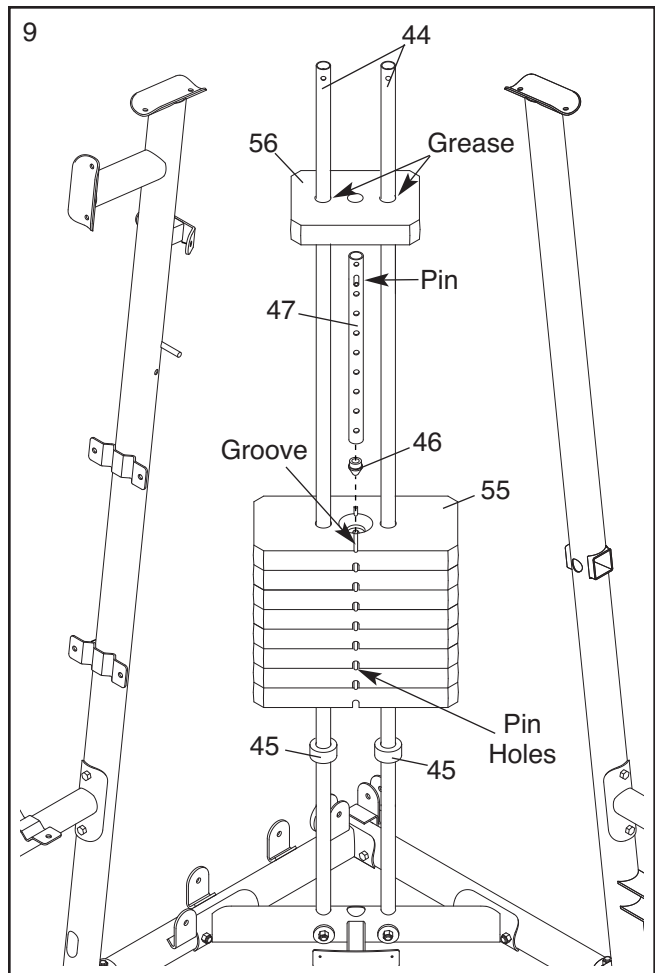

- Attach the Right Top Frame (5) to the Right Upright (2) with two M8 x 78mm Bolts (82), two M8 Washers (98), and two M8 Nylon Locknuts (91). **Do not tighten the Locknuts yet. Make sure the Weight Guides (44) are behind the Right Top Frame.**

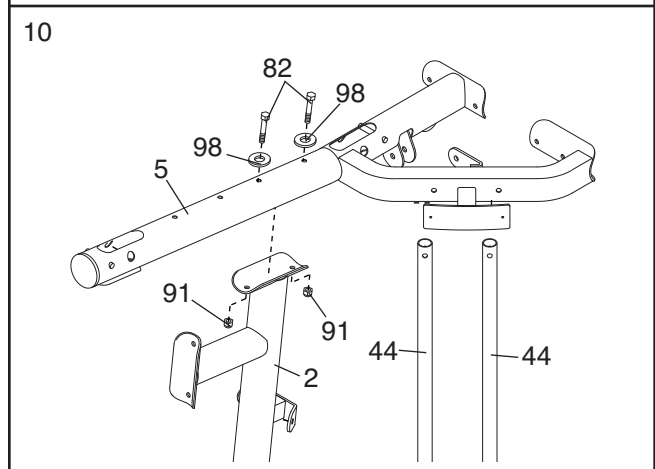

- Attach a Weight Guide (44) to the Right Top Frame (5) with an M8 x 78mm Bolt (82), two M8 Washers (98), and an M8 Nylon Locknut (91). **Do not tighten the Locknut yet.**

Repeat this step with the other Weight Guide (44).

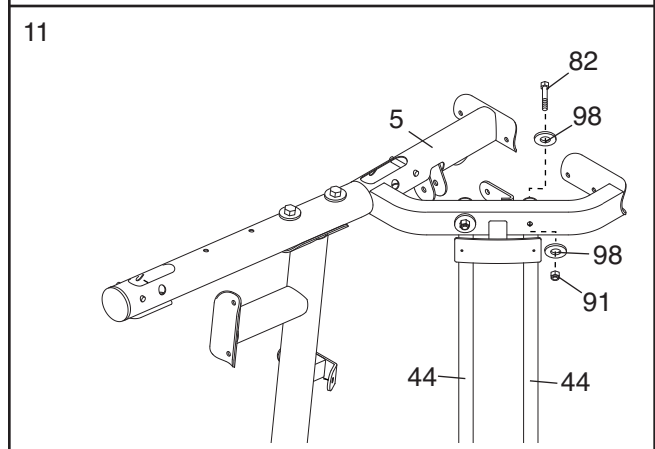

12. Attach the Left Top Frame (36) to the Right Top Frame (5) with four M8 x 78mm Bolts (82), two M8 Washers (98), a Support Plate (31), and four M8 Nylon Locknuts (91). **Do not tighten the Locknuts yet.**

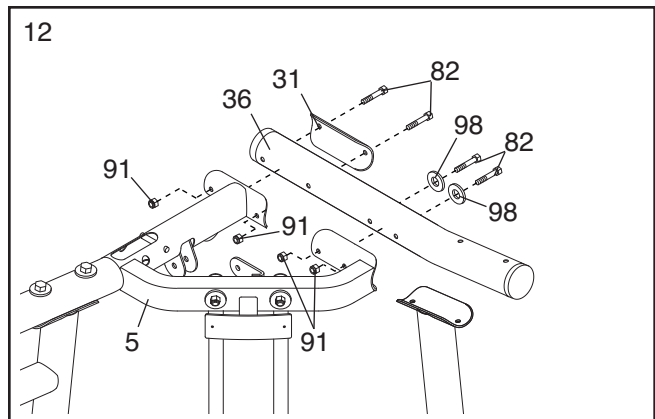

13. Attach the Left Top Frame (36) to the Left Upright (26) with two M8 x 78mm Bolts (82), a Support Plate (31), and two M8 Nylon Locknuts (91). **Do not tighten the Locknuts yet.**

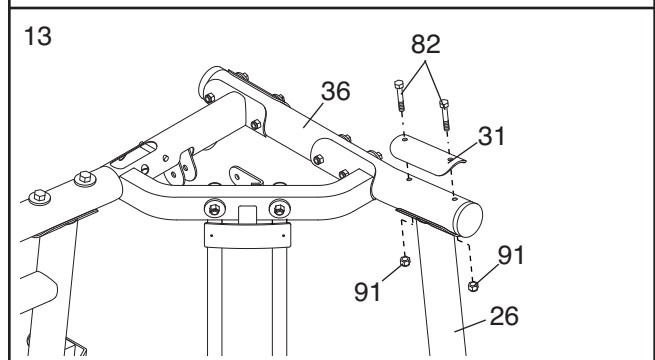

14. Orient the Butterfly Frame (14) as shown. Attach the Butterfly Frame to the Right Upright (2) with two M8 x 72mm Bolts (85), two M8 Washers (98), and two M8 Nylon Locknuts (91). **Do not tighten the Locknuts yet.**

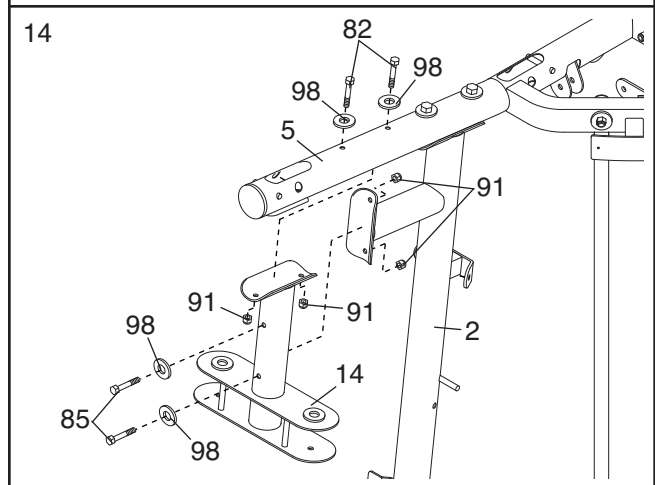

Attach the Butterfly Frame (14) to the Right Top Frame (5) with two M8 x 78mm Bolts (82), two M8 Washers (98), and two M8 Nylon Locknuts (91).

**Tighten the M8 Nylon Locknuts (91) used in steps 3–14.**

## Arm Assembly

15. Wet the lower end of the Left Butterfly Arm (6) with soapy water. Slide a Large Foam Pad (15) onto the Left Butterfly Arm.

**Note: an entire grease packet should be used for this step.** Grease an M10 x 85mm Bolt (74) and the indicated edges of two Arm Bushing (23) with a grease packet. Attach the Left Butterfly Arm (6) to the Butterfly Frame (14) with the Bolt (74), an M10 Large Washer (100), the two Arm Bushings, and an M10 Nylon Locknut (90). **Make sure the bolt head fits inside of the hole in the Butterfly Frame.**

**Repeat this step with the Right Butterfly Arm (7).**

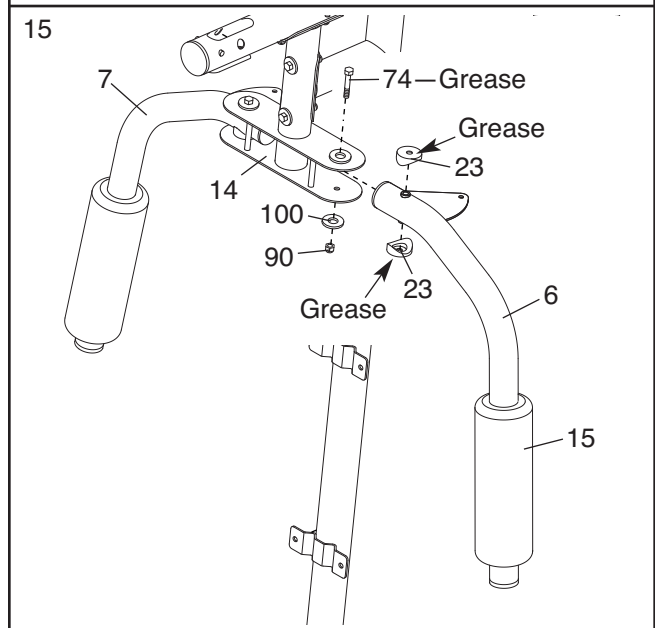

16. Attach the Leg Bumper (59) to the Right Seat Frame (3) with an M4 x 16mm Self-tapping Screw (89) and an M4 Washer (96).

Grease an M10 x 75mm Bolt (60). Attach the Leg Lever (4) to the Right Seat Frame (3) with the Bolt and an M10 Nylon Locknut (90). **Make sure the "U"-rod is on the indicated side of the Leg Lever. Do not overtighten the Locknut; the Leg Lever must be able to pivot easily.**

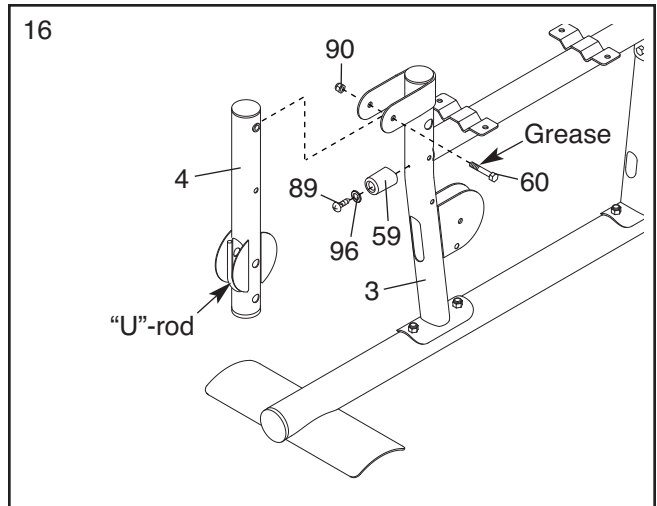

17. Grease an M10 x 108mm Bolt (72). Orient the Press Frame (29) so that the welded tube is on the side toward the Left Upright (26). Attach the Press Frame to the Left Base (25) with the Bolt and an M10 Nylon Locknut (90). **Do not overtighten the Locknut; the Press Frame must be able to pivot easily.**

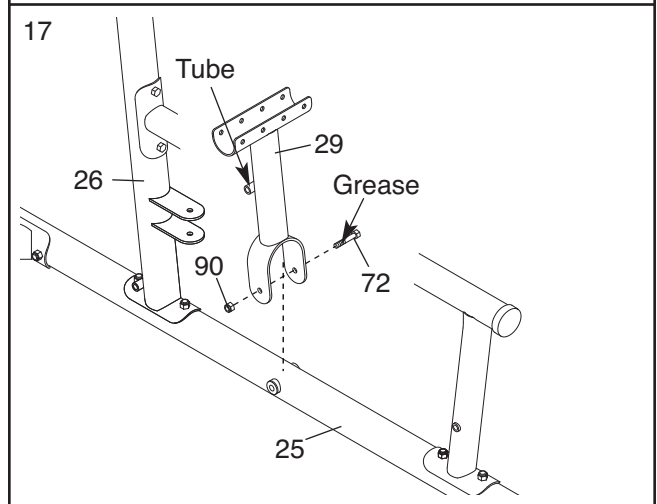

18. Attach a Press Handle (32) to a Press Arm (30) with an M10 x 65mm Bolt (77), two M10 Washers (99), two M10 x 12mm Spacers (101), and an M10 Nylon Locknut (90).

Attach a Press Arm Cap (34) to the Press Arm (30) with an M10 x 45mm Button Bolt (81) and an M10 Large Washer (100).

**Repeat this step with the other Press Arm (30).**

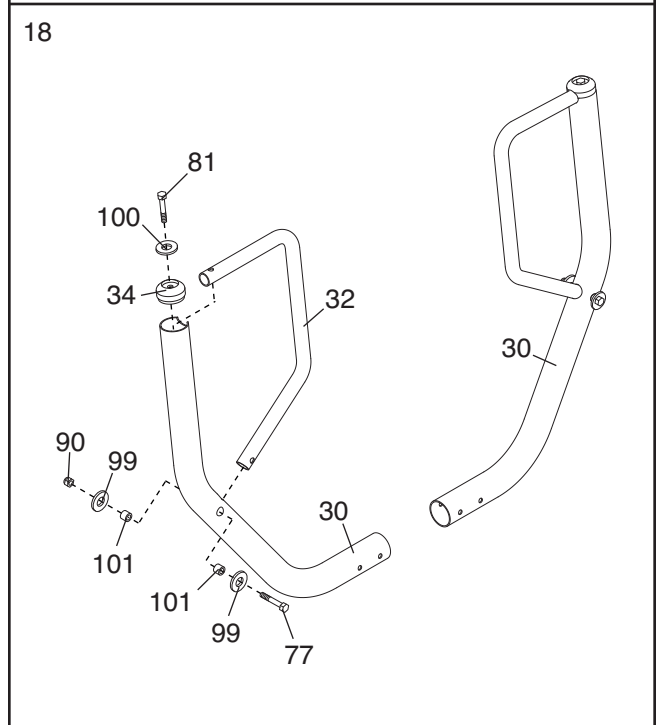

19. Attach a Press Arm (30) to the Press Frame (29) with two M8 x 69mm Bolt (86) and two M8 Nylon Locknuts (91).

**Repeat this step with the other Press Arm (30).**

20. Grease an M10 x 108mm Bolt (72). Attach the Leg Press Frame (28) to the Left Base (25) with the Bolt and an M10 Nylon Locknut (90). **Do not overtighten the Locknut; the Leg Press Frame must be able to pivot easily.**

21. Grease an M10 x 77mm Bolt (76). Attach the Foot Plate (38) to the Leg Press Frame (28) with the Bolt and an M10 Nylon Locknut (90). **Make sure the decal on the Foot Plate is right side up. Do not overtighten the Locknut; the Foot Plate must be able to pivot easily.**

## Cable Assembly

22. See the **CABLE DIAGRAMS** on pages 26 and 27 to identify the cables and to correctly assemble the cables.

**Identify the Press Cable (109).** Attach the Cable to the Leg Press Frame (28) with an M8 x 86mm Shoulder Bolt (37) and an M8 Nylon Locknut (91). **Do not overtighten the Locknut; the Cable must be able to pivot easily.**

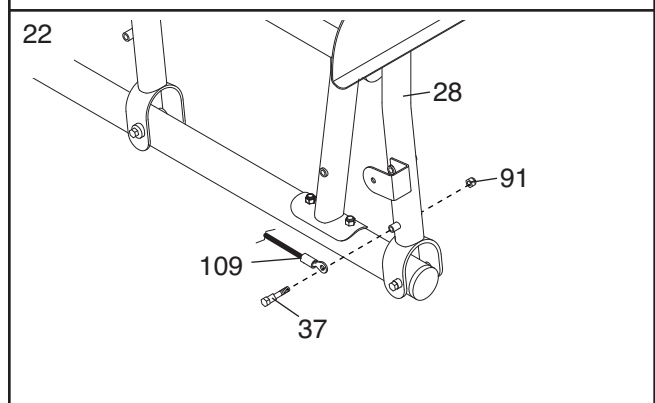
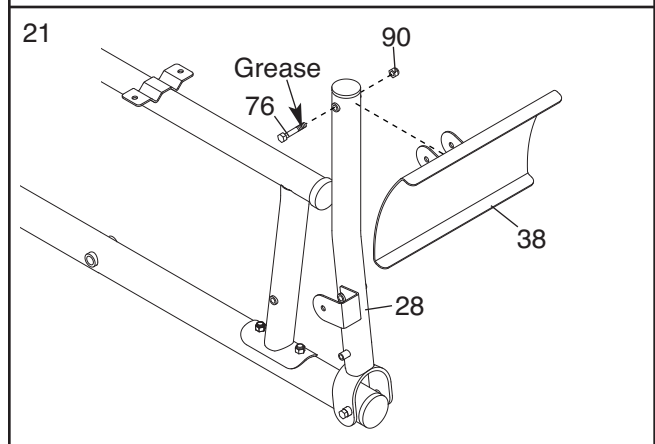
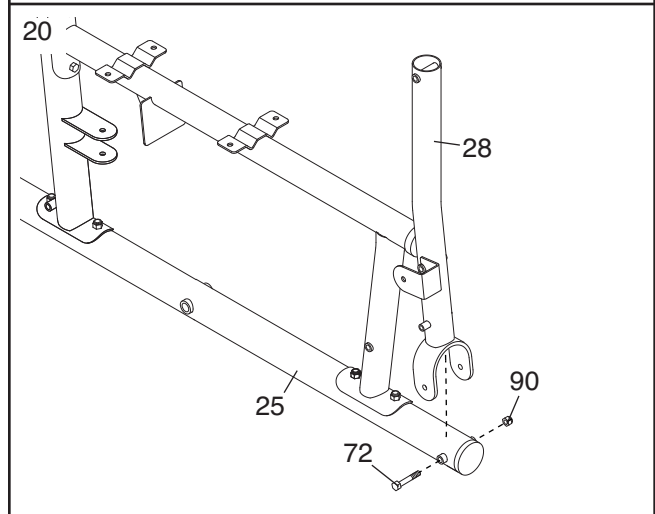
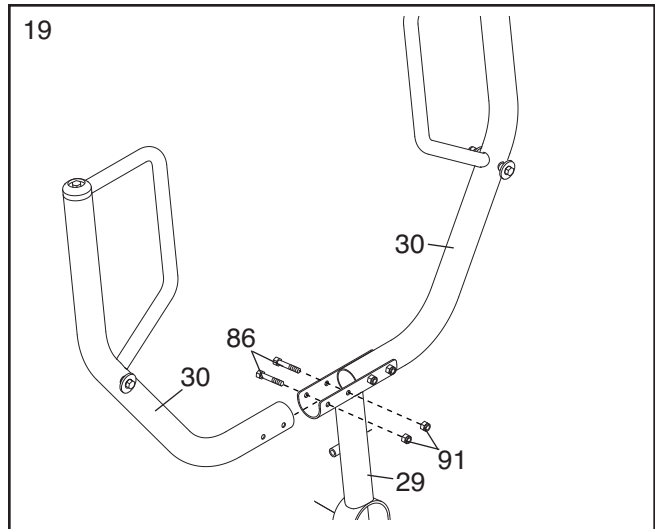

23. Wrap the Press Cable (109) around a 90mm Pulley (63). Attach the Pulley, two Half Finger Guards (66), a Cable Trap (68), and an M10 Washer (99) to the Left Seat Frame (27) with an M10 x 103mm Bolt (22) and an M10 Nylon Locknut (90). **Make sure the Cable Trap and the Finger Guards are oriented as shown.**

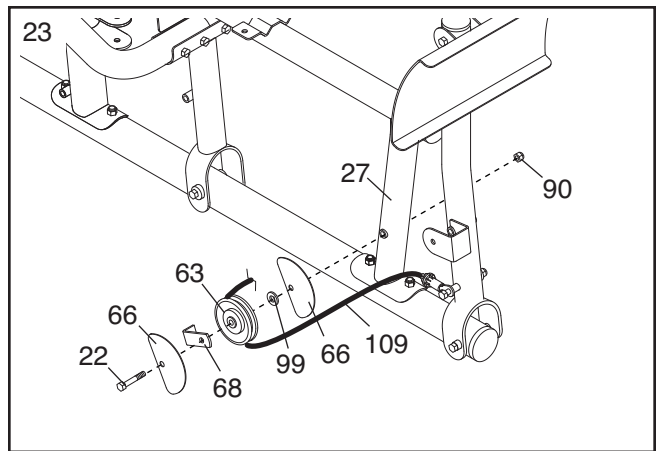

24. Wrap the Press Cable (109) around a "V"-pulley (62). Attach the "V"-pulley, two Half Finger Guards (66), and two M10 Washers (99) to the Leg Press Frame (28) with an M10 x 115mm Bolt (71) and an M10 Nylon Locknut (90). **Make sure the Finger Guards are oriented as shown.**

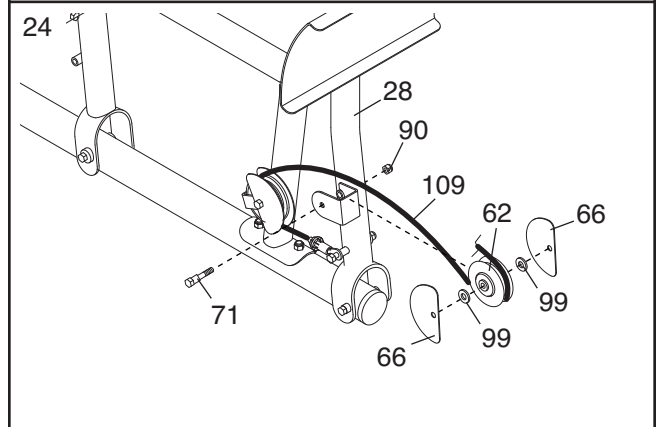

25. Wrap the Press Cable (109) around a 90mm Pulley (63). Attach the Pulley, two Half Finger Guards (66), a Cable Trap (68), and an M10 Washer (99) to the Left Upright (26) with an M10 x 108mm Bolt (72) and an M10 Nylon Locknut (90). **Make sure the Cable Trap and Finger Guards are oriented as shown.**

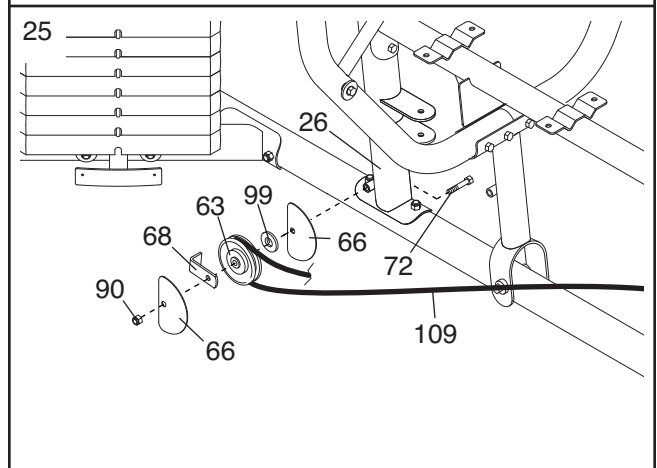

26. Wrap the Press Cable (109) around a 90mm Pulley (63). Attach the Pulley, two Half Finger Guards (66), a Cable Trap (68), and an M10 Washer (99) to the Press Frame (29) with an M10 x 135mm Bolt (70). **Make sure the Cable Trap and Finger Guards are oriented as shown.**

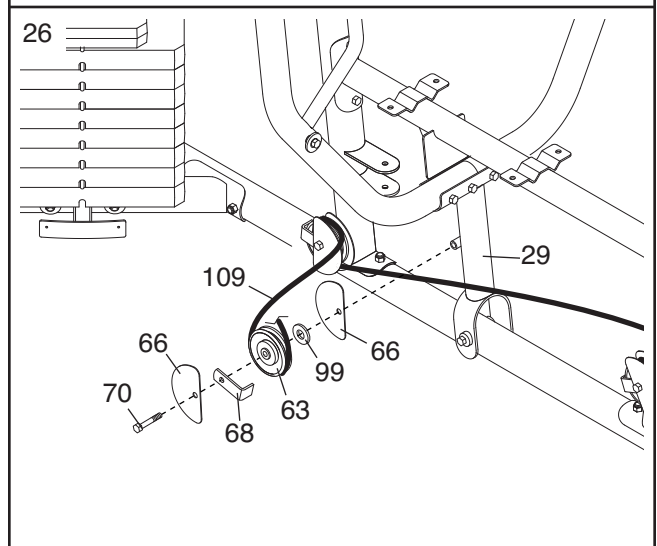

27. Wrap the Press Cable (109) around a “V”-pulley (62). Attach the “V”-pulley, two Half Finger Guards (66), a Large Cable Trap (111), and an M10 Washer (99) inside the bracket on the Left Upright (26) with an M10 x 65mm Bolt (77) and an M10 Nylon Locknut (90). **Make sure the Cable Trap and Finger Guards are oriented as shown.**

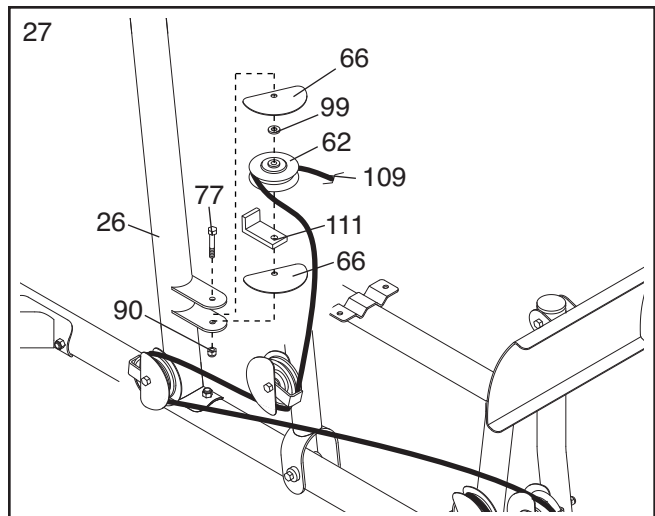

28. Wrap the Press Cable (109) around a 90mm Pulley (63). Attach the Pulley, two Half Finger Guards (66), a Cable Trap (68), and an M10 Washer (99) to the Press Frame (29) with the M10 x 135mm Bolt (70) used in step 26 and an M10 Nylon Locknut (90). **Make sure the Cable Trap and Finger Guards are oriented as shown.**

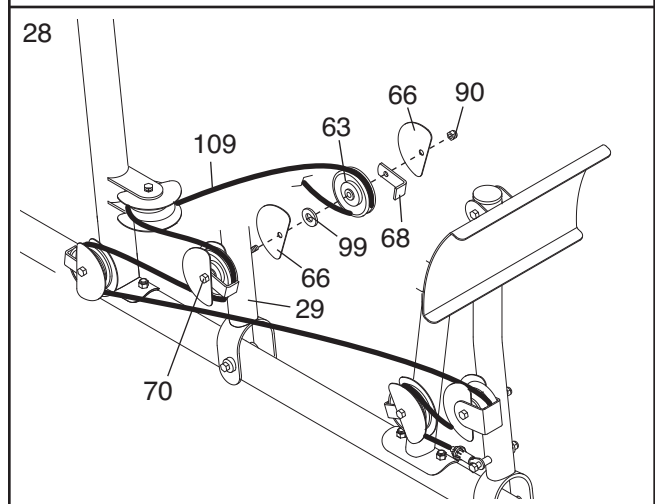

29. Wrap the Press Cable (109) under a 90mm Pulley (63). Attach the Pulley, two M10 Washers (99), and two Half Finger Guards (66) inside the bracket on the Left Base (25) with an M10 x 50mm Bolt (64) and an M10 Nylon Locknut (90). **Make sure the Finger Guards are oriented as shown.**

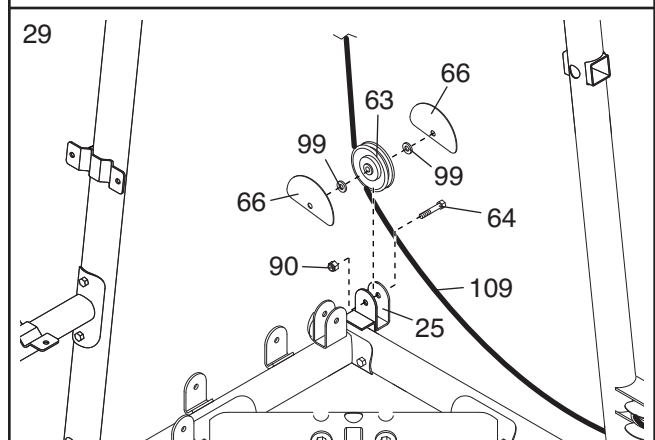

30. Wrap the Press Cable (109) over a 90mm Pulley (63). Attach the Pulley and a Cable Trap (68) to the Right Top Frame (5) with an M10 x 45mm Bolt (80) and an M10 Nylon Locknut (90). **Make sure the Cable Trap is oriented to hold the Cable in the groove of the Pulley.**

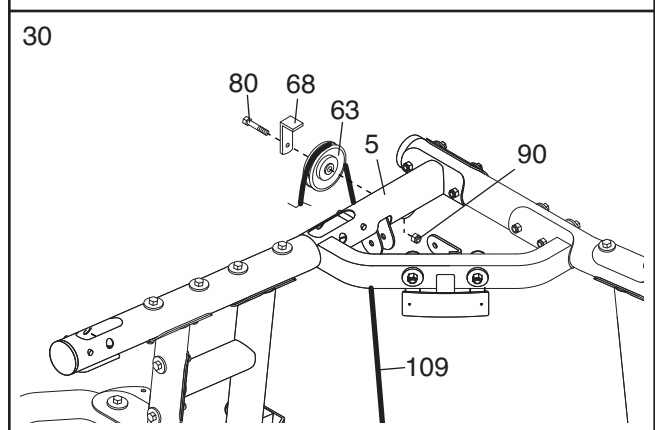

31. Attach the end of the Press Cable (109) to a “U”-bracket (50) with an M8 Washer (98) and an M8 Nylon Locknut (91). **Note: Do not completely tighten the Locknut; it should be tightened so that only two threads of the Cable show past the Locknut, as shown in the inset drawing.**

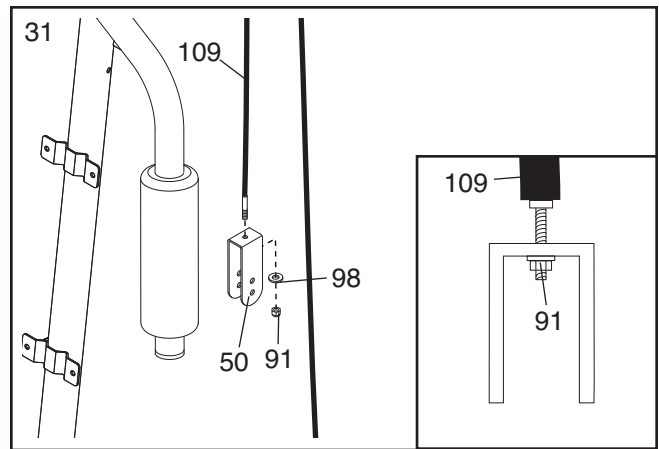

32. **Identify the Butterfly Cable (106).** Grease an M8 x 22mm Shoulder Bolt (39). Attach the Cable to the Left Butterfly Arm (6) with the Bolt and an M8 Nylon Locknut (91). **Make sure the flat edge of the Cable is against the Butterfly Arm.**

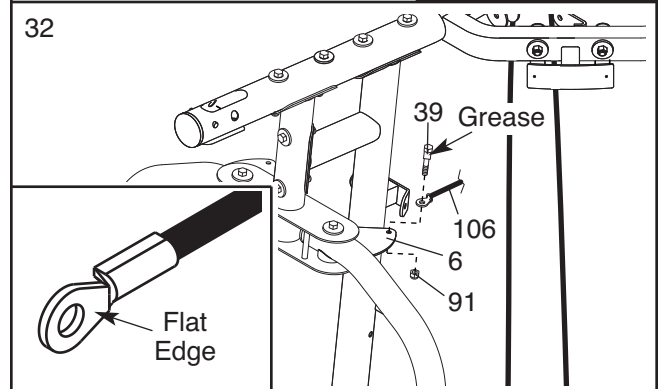

33. Wrap the Butterfly Cable (106) over a “V”-pulley (62). Attach the “V”-pulley, a Large Cable Trap (111), an M10 Washer (99), and two Full Finger Guards (104) to the Right Upright (2) with an M10 x 62mm Bolt (73) and an M10 Nylon Locknut (90).

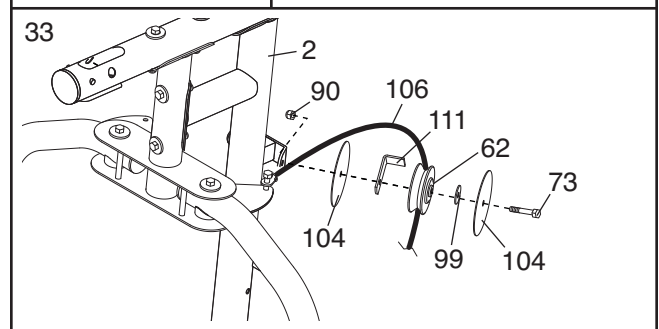

34. Wrap the Butterfly Cable (106) under a 90mm Pulley (63). Attach the Pulley and two Half Finger Guards (66) to the Double “U”-bracket (61) with an M10 x 48mm Bolt (84) and an M10 Nylon Locknut (90). **Make sure the Finger Guards are oriented as shown.**

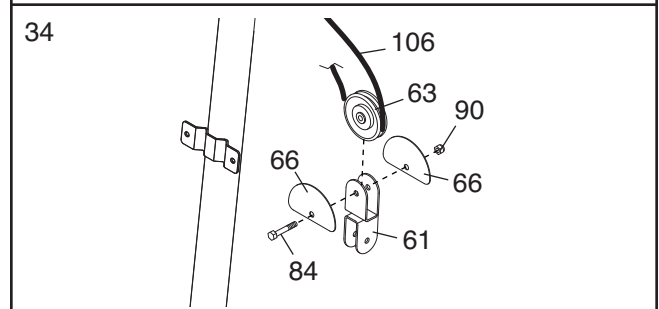

35. Wrap the Butterfly Cable (106) over a “V”-pulley (62). Attach the “V”-pulley, a Large Cable Trap (111), an M10 Washer (99), and two Full Finger Guards (104) to the Right Upright (2) with an M10 x 62mm Bolt (73) and an M10 Nylon Locknut (90).

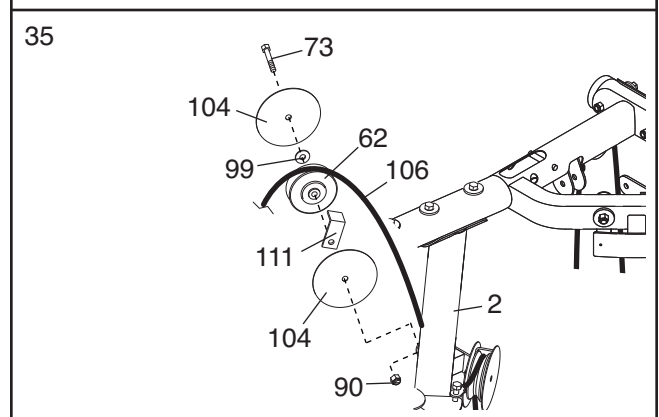



36. Grease an M8 x 22mm Shoulder Bolt (39). Attach the Butterfly Cable (106) to the Right Butterfly Arm (7) with the Bolt and an M8 Nylon Locknut (91). **Make sure the flat edge of the Cable is against the Butterfly Arm.**

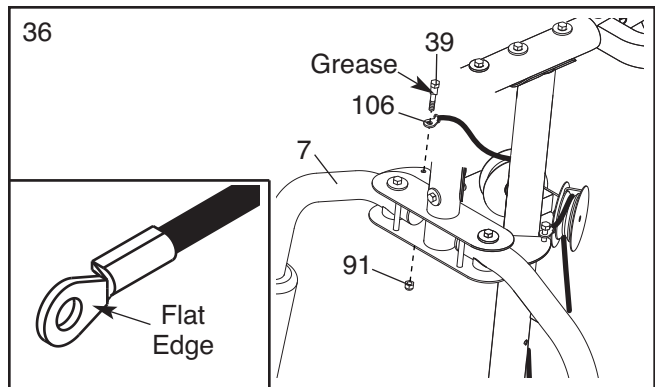

37. **Identify the Short Cable (108).** Attach the Cable to the M8 x 96mm Bolt (83) used in step 6 with an M8 Washer (98), an M8 x 13mm Spacer (103), and an M8 Nylon Locknut (91).

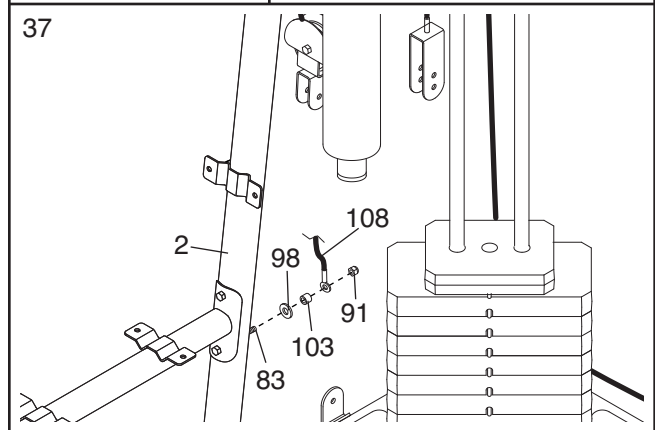

38. Wrap the Short Cable (108) over a 90mm Pulley (63). Attach the Pulley and two Half Finger Guards (66) to the Double "U"-bracket (61) with an M10 x 48mm Bolt (84) and an M10 Nylon Locknut (90). **Make sure the Finger Guards are oriented as shown.**

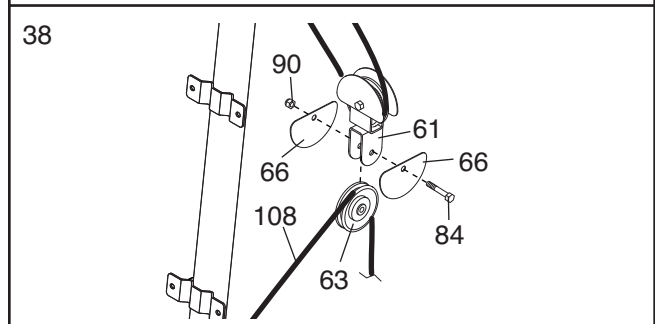

39. Attach the end of the Short Cable (108) to a "U"-bracket (50) with an M8 Washer (98) and an M8 Nylon Locknut (91). **Note: Do not completely tighten the Locknut; it should be tightened so that only two threads of the Cable show past the Locknut, as shown in the inset drawing.**

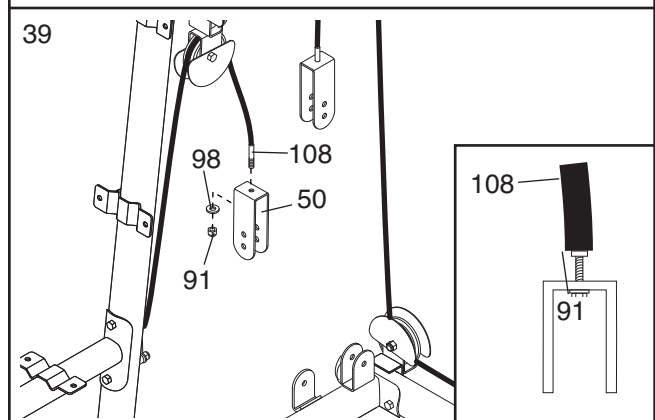

40. **Identify the Weight Cable (110).** Route the Cable up through the Right Top Frame (5) and over a 90mm Pulley (63). Attach the Pulley inside the Top Frame with an M10 x 80mm Bolt (75), two M10 Washers (99), two M10 x 19mm Spacers (102), and an M10 Nylon Locknut (90).

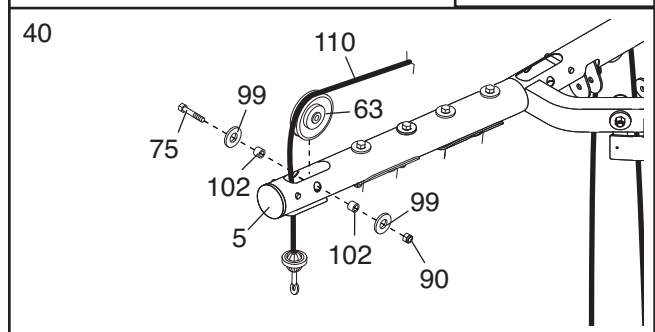



41. Route the Weight Cable (110) over a 90mm Pulley (63) and down through the Right Top Frame (5). Attach the Pulley inside the Top Frame with an M10 x 80mm Bolt (75), two M10 Washers (99), two M10 x 19mm Spacers (102), and an M10 Nylon Locknut (90).

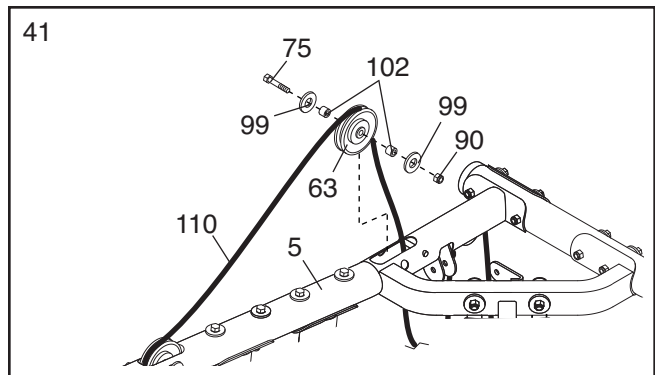

42. Wrap the Weight Cable (110) under a 90mm Pulley (63). Attach the Pulley, a Cable Trap (68), and two Half Finger Guards (66) at the second hole from the top of the two Pulley Plates (51) with an M10 x 50mm Bolt (64) and an M10 Nylon Locknut (90). **Make sure the Cable Trap and Finger Guards are oriented as shown.**

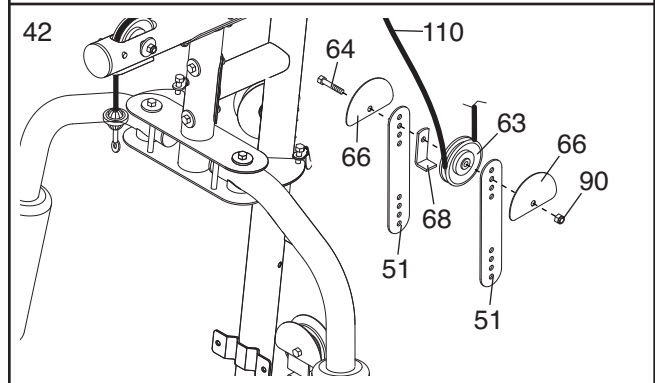

43. Wrap the Weight Cable (110) over a 90mm Pulley (63). Attach the Pulley to the indicated bracket on the Right Top Frame (5) with an M10 x 45mm Bolt (80) and an M10 Nylon Locknut (90).

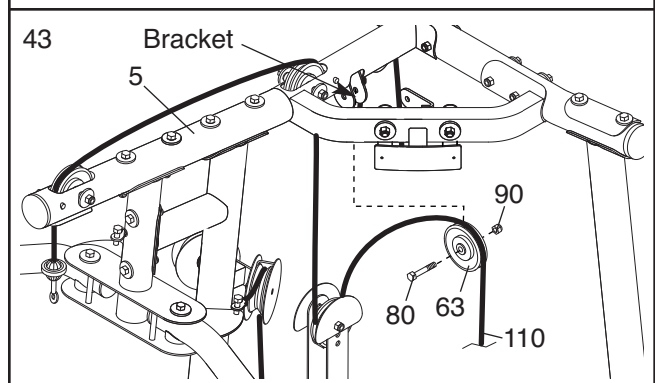

44. Wrap the Weight Cable (110) over a 90mm Pulley (63). Attach the Pulley and a Cable Trap (68) to the indicated bracket on the Right Top Frame (5) with an M10 x 45mm Bolt (80) and an M10 Nylon Locknut (90). **Make sure the Cable Trap is oriented to hold the Cable in the groove of the Pulley.**

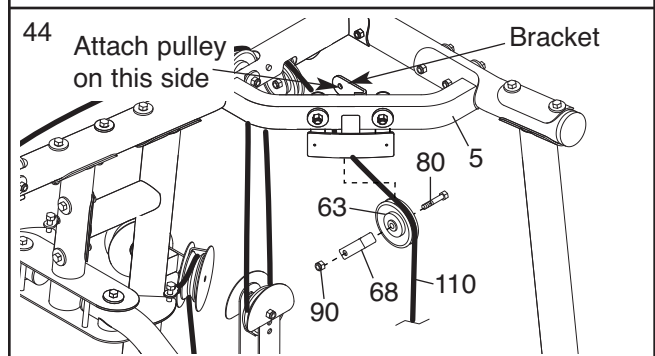

45. Set the M12 Washer (33) on top of the Weight Tube (47). Thread the M12 Nut (49) all the way onto the Weight Cable (110).

Thread the Weight Cable (110) into the Weight Tube (47) a couple of turns.

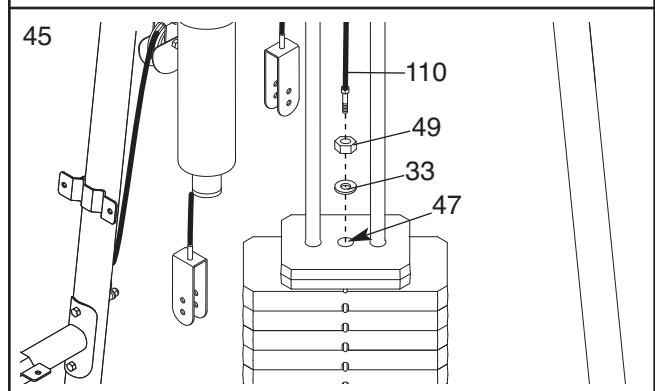

46. **Identify the Ab Cable (107).** Route the small ball on the Cable through the Leg Lever (4) and the Right Seat Frame (3). **Make sure the Cable is over the rod in the Seat Frame.**

Attach a 90mm Pulley (63) inside the Leg Lever (4), over the Ab Cable (107), with an M10 x 65mm Bolt (77), two M10 Washers (99), two M10 x 12mm Spacers (101), and an M10 Nylon Locknut (90).

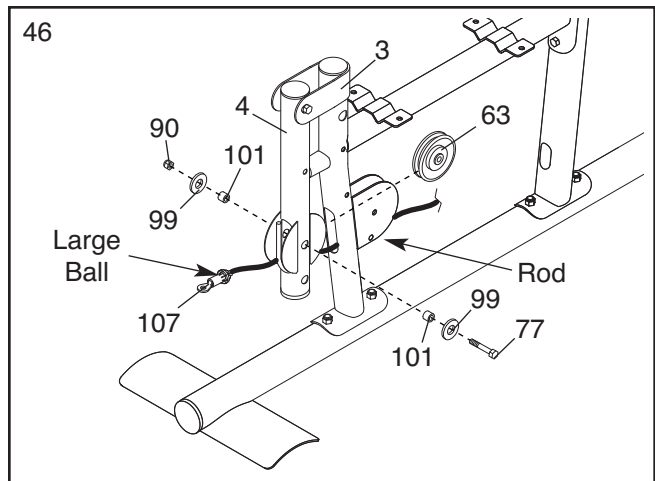

47. Attach a 90mm Pulley (63) inside the Right Seat Frame (3), over the Ab Cable (107), with an M10 x 45mm Bolt (80) and an M10 Nylon Locknut (90).

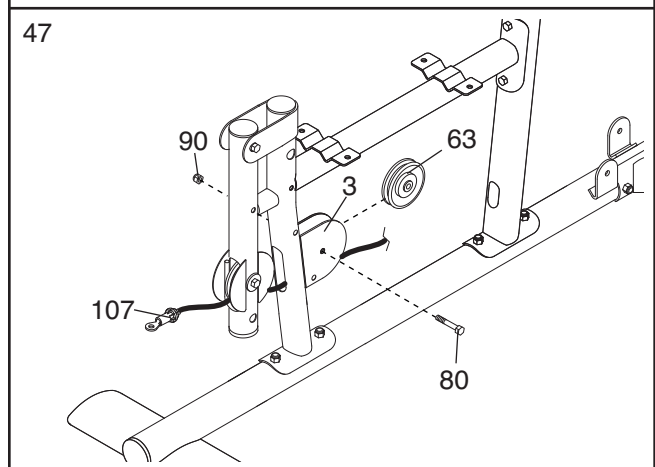

48. Route the Ab Cable (107) through the Right Upright (2) and under a 90mm Pulley (63). Attach the Pulley and two Half Finger Guards (66) to the Right Base (1) with an M10 x 50mm Bolt (64) and an M10 Nylon Locknut (90). **Make sure the Finger Guards are oriented as shown.**

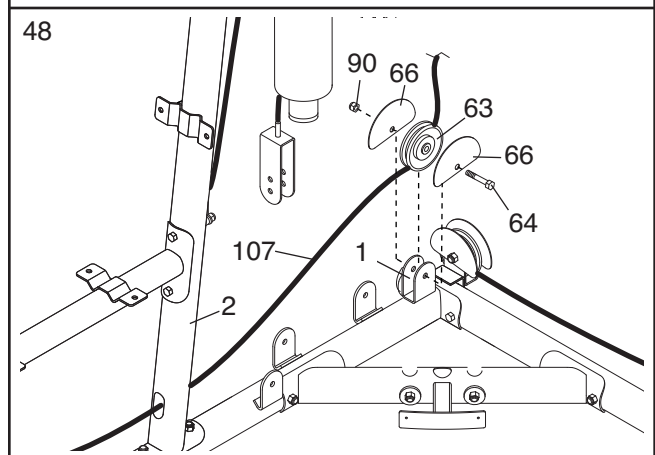

49. Wrap the Ab Cable (107) over a 90mm Pulley (63). Attach the Pulley, a Cable Trap (68), and two Half Finger Guards (66) to the lower hole in the indicated "U"-bracket (50) with an M10 x 50mm Bolt (64) and an M10 Nylon Locknut (90). **Make sure the Cable Trap and Finger Guards are oriented as shown.**

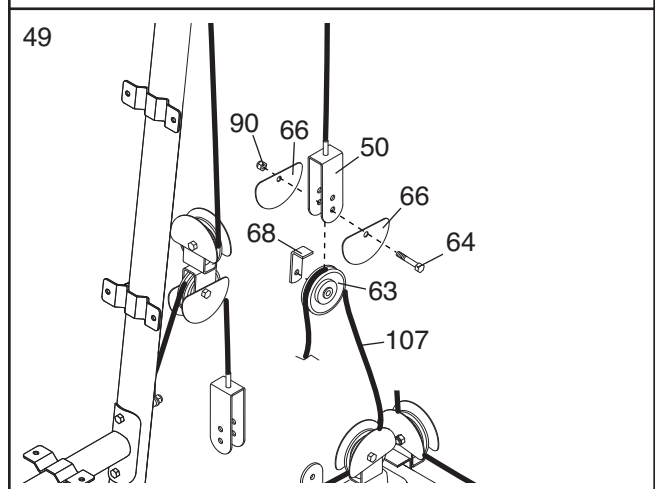

50. Wrap the Ab Cable (107) under a 90mm Pulley (63). Attach the Pulley, a Cable Trap (68), and two Half Finger Guards (66) to the Right Base (1) with an M10 x 50mm Bolt (64) and an M10 Nylon Locknut (90). **Make sure the Cable Trap and Finger Guards are oriented as shown.**

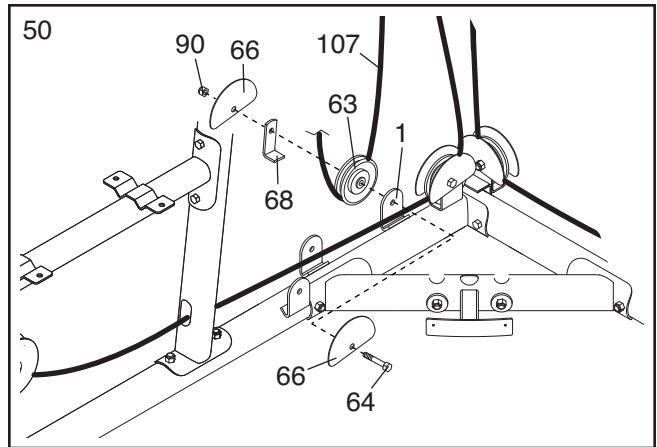

51. Wrap the Ab Cable (107) over a 90mm Pulley (63). Attach the Pulley, a Cable Trap (68), and two Half Finger Guards (66) at the second hole from the bottom of the two Pulley Plates (51) with an M10 x 50mm Bolt (64) and an M10 Nylon Locknut (90). **Make sure the Cable Trap and Finger Guards are oriented as shown.**

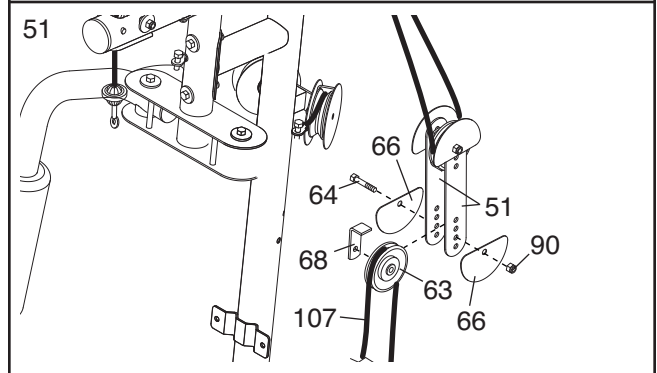

52. Wrap the Ab Cable (107) under a 90mm Pulley (63). Attach the Pulley, a Cable Trap (68), and two Half Finger Guards (66) to the Right Base (1) with an M10 x 50mm Bolt (64) and an M10 Nylon Locknut (90). **Make sure the Cable Trap and Finger Guards are oriented as shown.**

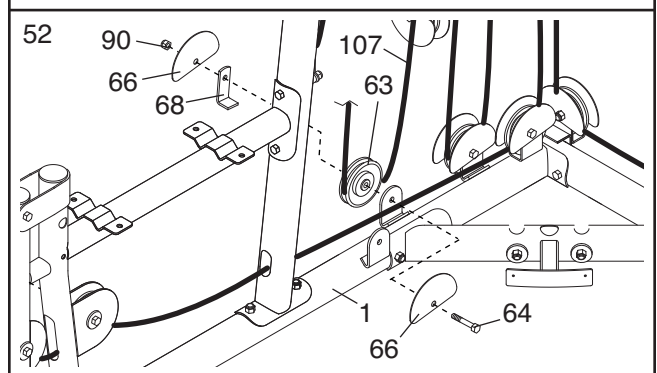

53. Wrap the Ab Cable (107) over a 90mm Pulley (63). Attach the Pulley, a Cable Trap (68), and two Half Finger Guards (66) to the lower hole in the indicated "U"-bracket (50) with an M10 x 50mm Bolt (64) and an M10 Nylon Locknut (90). **Make sure the Cable Trap and Finger Guards are oriented as shown.**

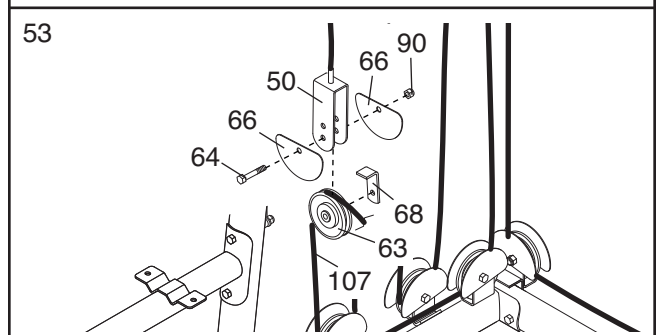

54. Wrap the Ab Cable (107) under a 90mm Pulley (63). Attach the Pulley, a Cable Trap (68) and two Half Finger Guards (66) to the Right Base (1) with an M10 x 50mm Bolt (64) and an M10 Nylon Locknut (90). **Make sure the Cable Trap and Finger Guards are oriented as shown.**

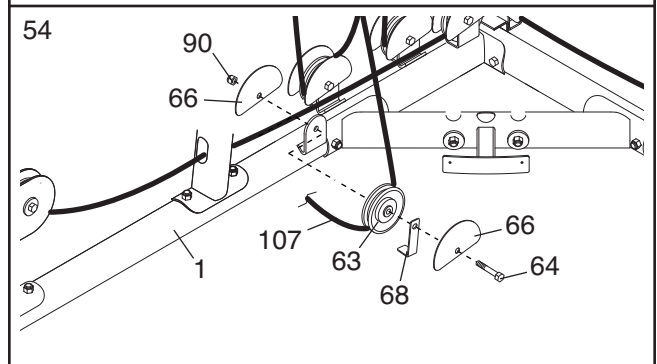

55. Wrap the Ab Cable (107) over a 90mm Pulley (63). Attach the Pulley and the two Quarter Finger Guards (105) to the Right Upright (2) with an M10 x 108mm Bolt (72), an M10 Washer (99), and an M10 Nylon Locknut (90). **Make sure that the rod is inserted through both Finger Guards and is over the Cable.**

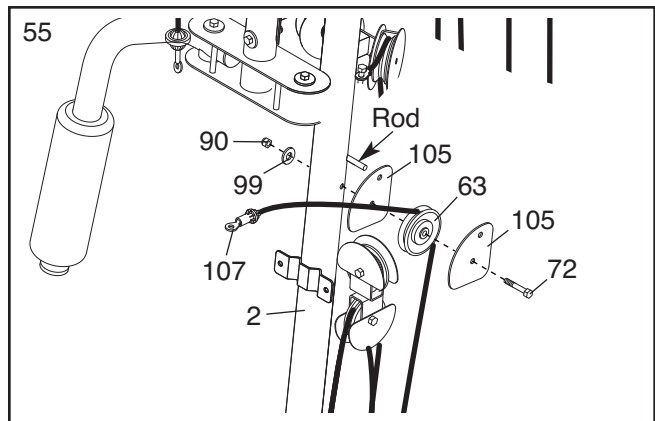

56. Tighten the Weight Cable (110) into the Weight Tube (not shown) until all the slack is taken out of the cables. Tighten the M12 Nut (49) on the Weight Cable against the M12 Washer (33).

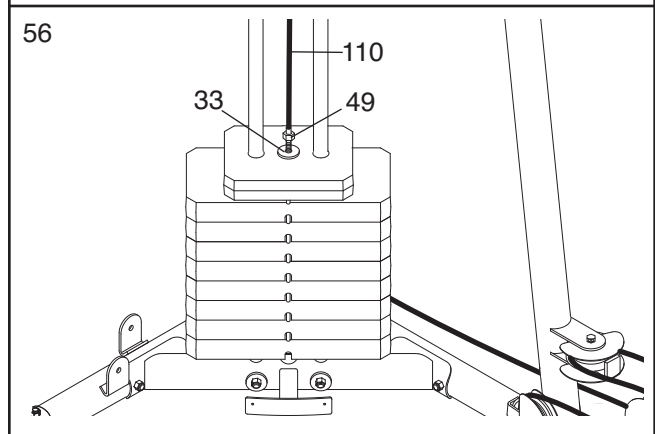

## Seat Assembly

57. Attach the Press Backrest (113) to the Backrest Frame (53) with two M6 x 16mm Screws (88), an M6 x 35mm Screw (78), and an M6 Washer (97).

Slide the Backrest Frame (53) into the Left Upright (26). Engage the Knob (43) into the Upright and Backrest Frame, and turn it clockwise until it is tight.

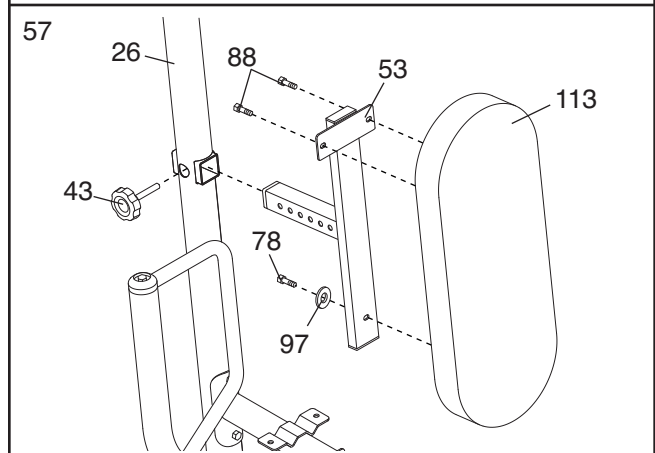

58. Attach the Seat With Tag (12) to the Left Seat Frame (27) with four M6 x 16mm Screws (88).

**Repeat this step with the Seat (8) and the Right Seat Frame (not shown).**

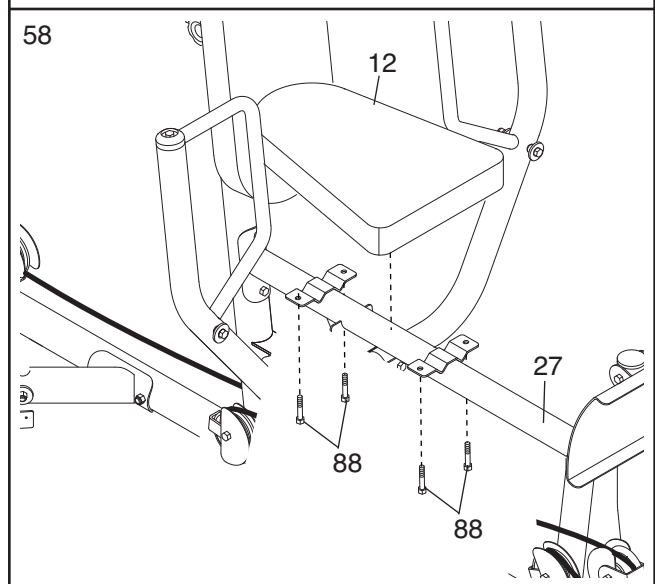

59. Attach the Butterfly Backrest (9) to the Right Upright (2) with four M6 x 16mm Screws (88).

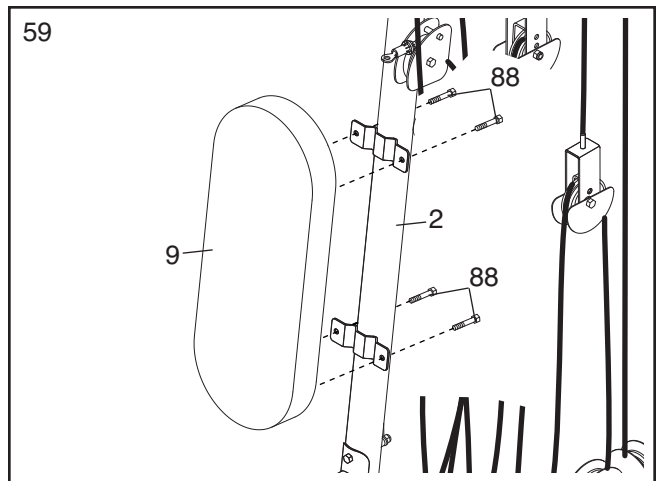

60. Press the two Shroud Covers (11) onto the Shroud (10). Attach the Shroud to the Right Top Frame (5) and the Center Base (52) with four M6 x 22mm Bolts (87), four M6 Washers (97), and four M6 Nylon Locknuts (92). **Be careful not to scratch yourself when reaching through the hole in the Shroud.**

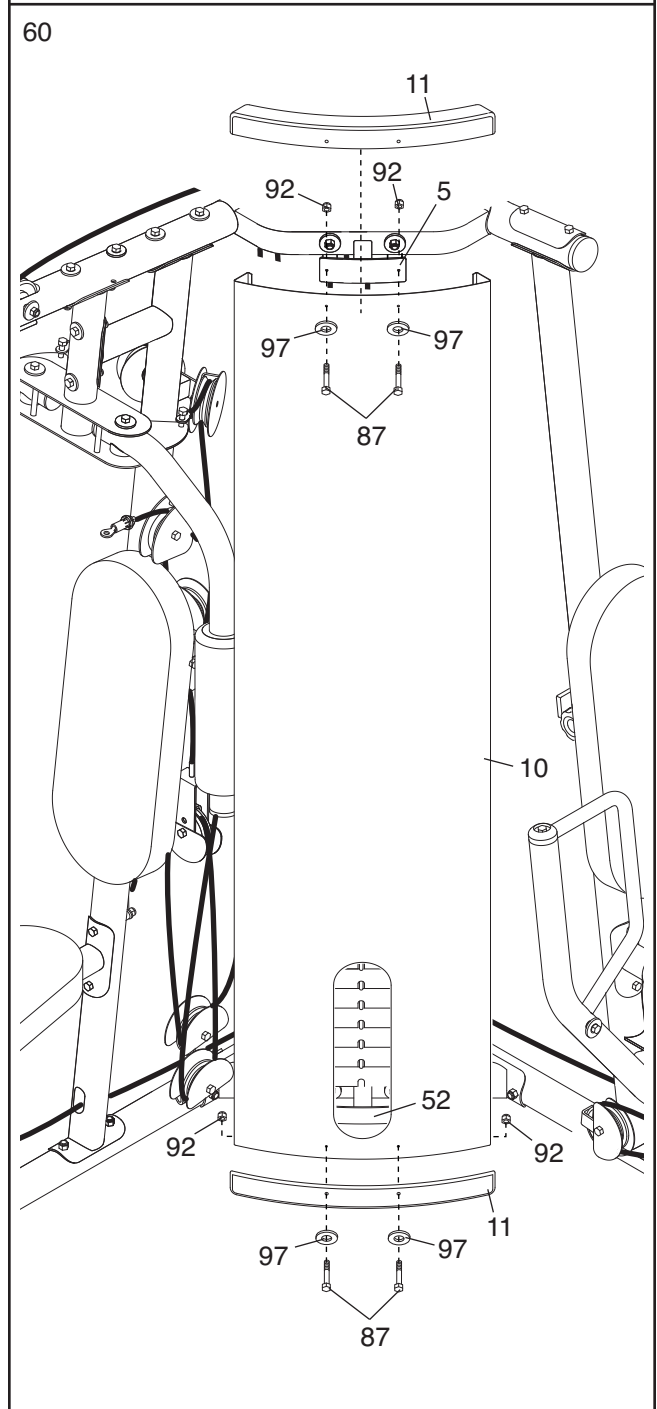

61. Attach the Lock Plate (21) to the Right Seat Frame (3) with an M8 x 68mm Shoulder Bolt (41), an M8 Washer (98), and an M8 Nylon Locknut (91). **Do not overtighten the Locknut; the Lock Plate must be able to pivot easily.**

Attach the Leg Pin (24) to the Right Seat Frame (3) with an M4 x 16mm Self-tapping Screw (89). Insert the Leg Pin through the Leg Lever (4) and the Lock Plate (21).

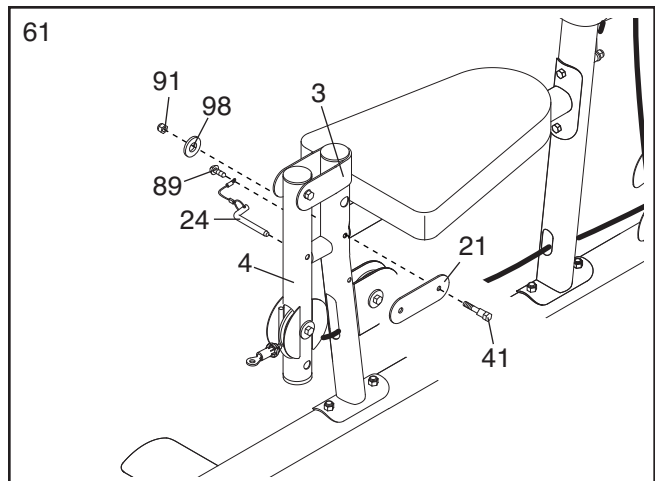

62. Insert the Long Pad Tube (16) into the Right Seat Frame (3). Slide two Small Foam Pads (18) onto the Pad Tube. Press two Foam Caps (17) into the Pad Tube.

**Repeat this step with the Leg Lever (4) and the Short Pad Tube (35).**

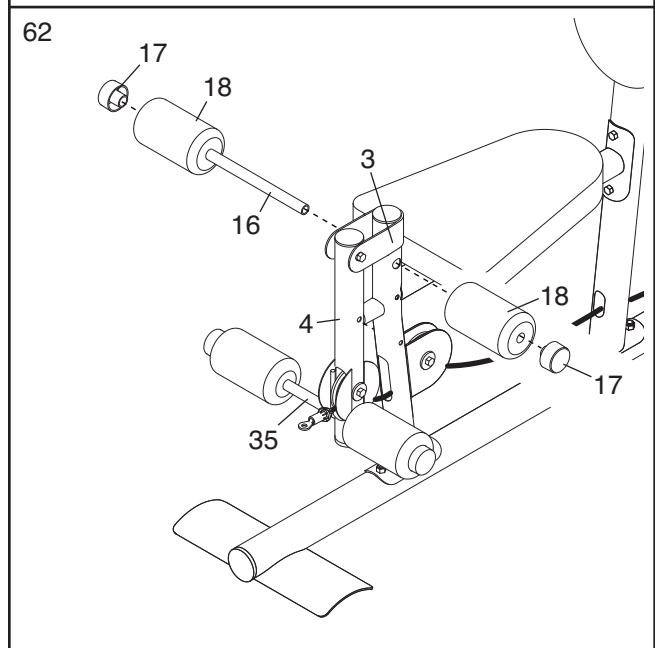

63. Make sure that all parts have been properly tightened. The use of the remaining parts will be explained in ADJUSTMENTS, beginning on the following page.

Before using the weight system, pull each cable a few times to make sure that the cables move smoothly over the pulleys. If one of the cables does not move smoothly, find and correct the problem. **IMPORTANT: If the cables are not properly installed, they may be damaged when heavy weight is used. See the CABLE DIAGRAMS on pages 26 and 27 of this manual for proper cable routing. If there is any slack in the cables, you will need to remove the slack by tightening the cables. See MAINTENANCE on page 28.**

**MAKE ASSEMBLY EASIER. REMOVE AND USE THIS  
PART IDENTIFICATION CHART DURING ASSEMBLY.**

**SAVE THIS PART IDENTIFICATION CHART FOR FUTURE REFERENCE**

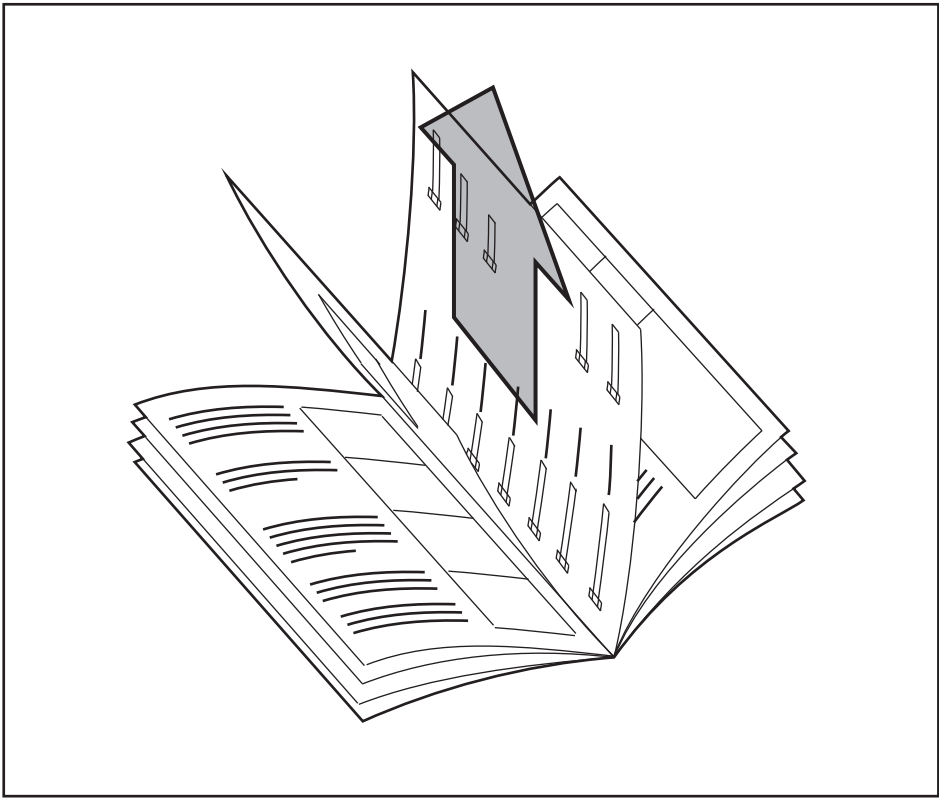

# PART IDENTIFICATION CHART – Model No. WEMSSY2915.0

See the drawings below to identify small parts used in assembly. The number in parentheses by each drawing is the key number of the part, from the PART LIST in the center of this manual. **Note: Some small parts may have been pre-attached. If a part is not in the parts bag, check to see if it has been pre-attached. If a part is missing, please call the telephone number on the warranty card accompanying this manual.**



M6 Nylon Locknut (92)

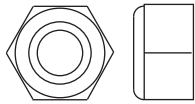

M8 Nylon Locknut (91)

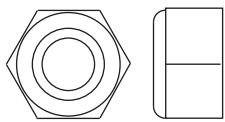

M10 Nylon Locknut (90)

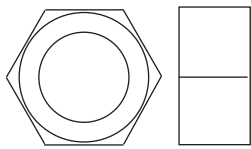

M12 Nut (49)

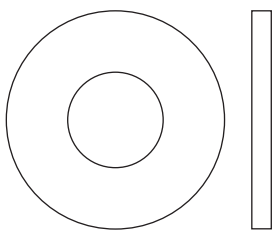

M12 Washer (33)

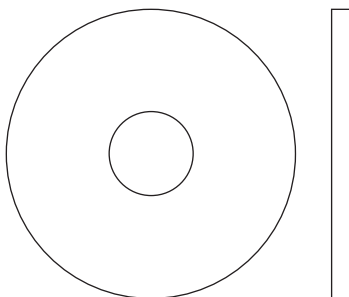

M10 Large Washer (100)



M4 Washer (96)

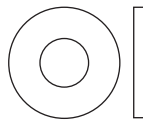

M6 Washer (97)

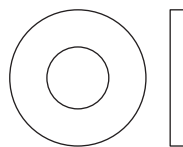

M8 Washer (98)

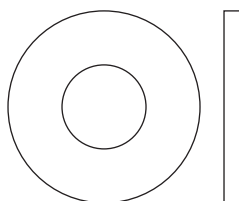

M10 Washer (99)



M10 x 75mm Bolt (60)

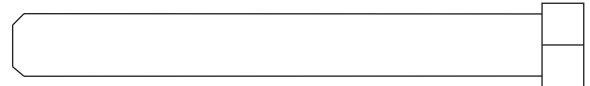

M8 x 72mm Bolt (85)

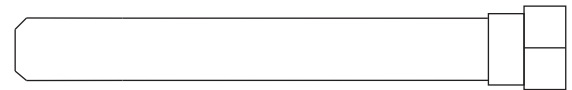

M8 x 68mm Shoulder Bolt (41)

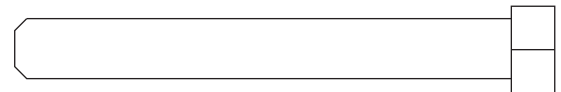

M8 x 69mm Bolt (86)

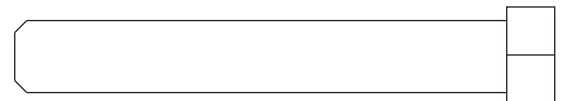

M10 x 65mm Bolt (77)

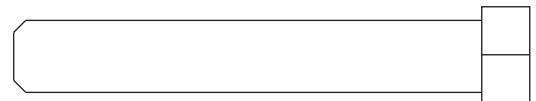

M10 x 62mm Bolt (73)

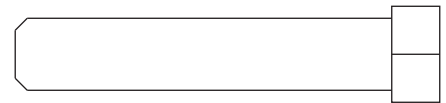

M10 x 50mm Bolt (64)

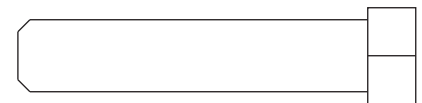

M10 x 48mm Bolt (84)

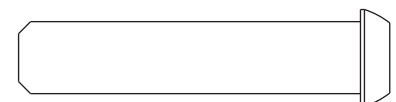

M10 x 45mm Button Bolt (81)



M10 x 45mm Bolt (80)



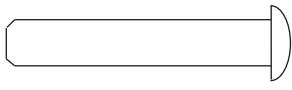

M6 x 35mm Screw (78)

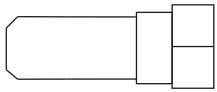

M8 x 22mm Shoulder Bolt (39)

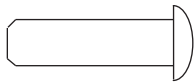

M6 x 22mm Bolt (87)

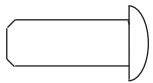

M6 x 16mm Screw (88)

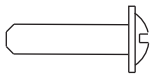

M4 x 16mm Self-tapping Screw (89)

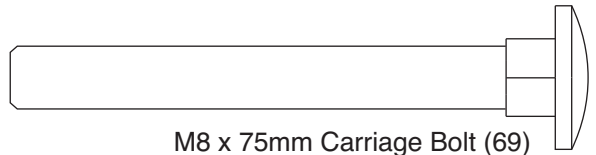

M8 x 75mm Carriage Bolt (69)



M10 x 77mm Bolt (76)

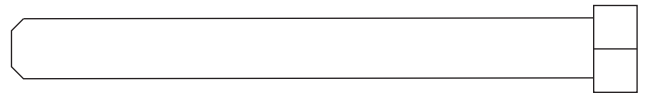

M8 x 78mm Bolt (82)

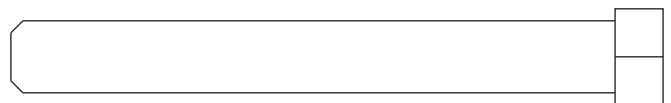

M10 x 80mm Bolt (75)

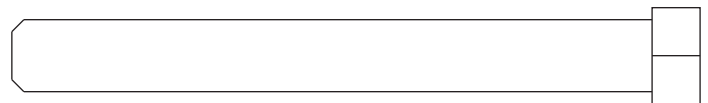

M10 x 85mm Bolt (74)

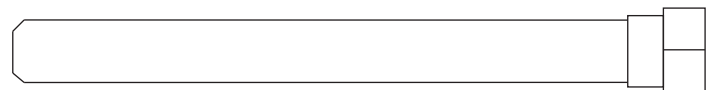

M8 x 86mm Shoulder Bolt (37)

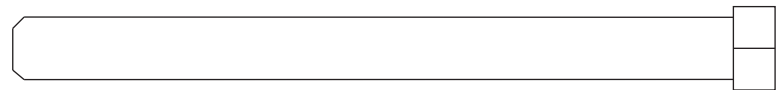

M8 x 96mm Bolt (83)

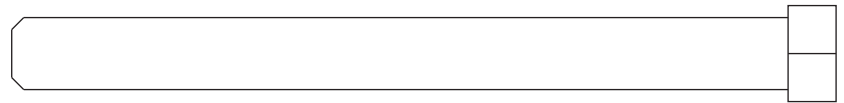

M10 x 103mm Bolt (22)



M10 x 108mm Bolt (72)

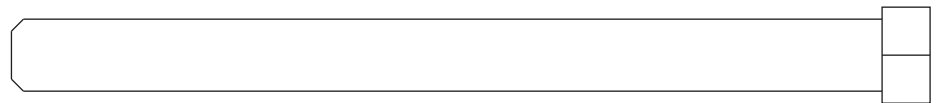

M10 x 115mm Bolt (71)

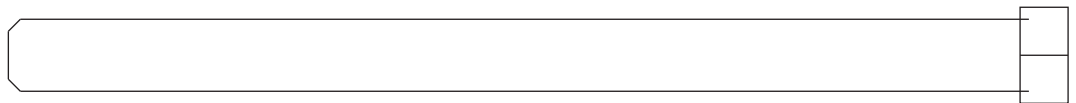

M10 x 135mm Bolt (70)

**MAKE ASSEMBLY EASIER. REMOVE AND USE THIS PART LIST/EXPLODED DRAWING DURING ASSEMBLY.**

**SAVE THIS PART LIST/EXPLODED DRAWING FOR FUTURE REFERENCE**

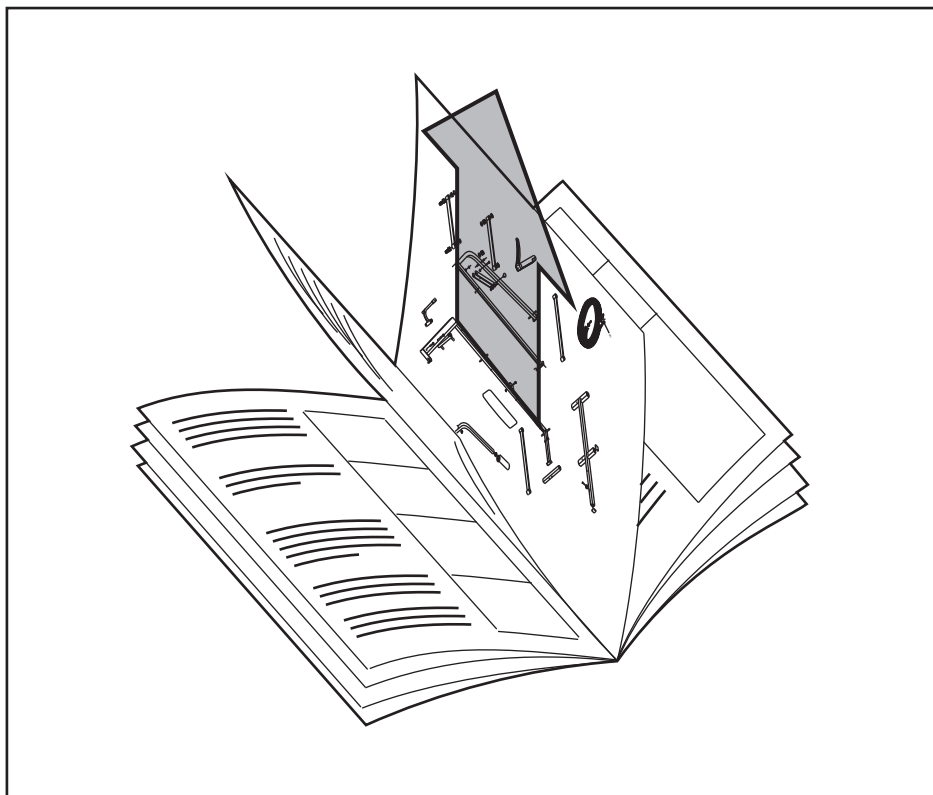

# PART LIST—Model No. WEMSSY2915.0

R0306A

Key No.	Qty.	Description	Key No.	Qty.	Description
1	1	Right Base	60	1	M10 x 75mm Bolt
2	1	Right Upright	61	1	Double "U"-bracket
3	1	Right Seat Frame	62	4	"V"-pulley
4	1	Leg Lever	63	23	90mm Pulley
5	1	Right Top Frame	64	9	M10 x 50mm Bolt
6	1	Left Butterfly Arm	65	1	Lock Pin
7	1	Right Butterfly Arm	66	34	Half Finger Guard
8	1	Seat	67	2	Base Bushing
9	1	Butterfly Backrest	68	13	Cable Trap
10	1	Shroud	69	8	M8 x 75mm Carriage Bolt
11	2	Shroud Cover	70	1	M10 x 135mm Bolt
12	1	Seat with Tag	71	1	M10 x 115mm Bolt
13	1	Lat Bar	72	4	M10 x 108mm Bolt
14	1	Butterfly Frame	73	2	M10 x 62mm Bolt
15	2	Large Foam Pad	74	2	M10 x 85mm Bolt
16	1	Long Pad Tube	75	2	M10 x 80mm Bolt
17	4	Foam Cap	76	1	M10 x 77mm Bolt
18	4	Small Foam Pad	77	4	M10 x 65mm Bolt
19	6	63mm Round Inner Cap	78	1	M6 x 35mm Screw
20	8	50mm Round Inner Cap	79	1	Ab Strap
21	1	Lock Plate	80	4	M10 x 45mm Bolt
22	1	M10 x 103mm Bolt	81	2	M10 x 45mm Button Bolt
23	4	Arm Bushing	82	23	M8 x 78mm Bolt
24	1	Leg Pin	83	1	M8 x 96mm Bolt
25	1	Left Base	84	2	M10 x 48mm Bolt
26	1	Left Upright	85	2	M8 x 72mm Bolt
27	1	Left Seat Frame	86	4	M8 x 69mm Bolt
28	1	Leg Press Frame	87	4	M6 x 22mm Bolt
29	1	Press Frame	88	14	M6 x 16mm Screw
30	2	Press Arm	89	2	M4 x 16mm Self-tapping Screw
31	2	Support Plate	90	34	M10 Nylon Locknut
32	2	Press Handle	91	42	M8 Nylon Locknut
33	2	M12 Washer	92	4	M6 Nylon Locknut
34	2	Press Arm Cap	93	1	Handle
35	1	Short Pad Tube	94	1	Chain
36	1	Left Top Frame	95	3	Cable Clip
37	1	M8 x 86mm Shoulder Bolt	96	1	M4 Washer
38	1	Foot Plate	97	5	M6 Washer
39	2	M8 x 22mm Shoulder Bolt	98	29	M8 Washer
40	1	50mm Round Outer Cap	99	22	M10 Washer
41	1	M8 x 68mm Shoulder Bolt	100	4	M10 Large Washer
42	1	56mm Round Inner Cap	101	6	M10 x 12mm Spacer
43	1	Knob	102	4	M10 x 19mm Spacer
44	2	Weight Guide	103	1	M8 x 13mm Spacer
45	2	Weight Bumper	104	4	Full Finger Guard
46	1	Weight Tube Bumper	105	2	Quarter Finger Guard
47	1	Weight Tube	106	1	Butterfly Cable
48	1	Lock	107	1	Ab Cable
49	1	M12 Nut	108	1	Short Cable
50	2	"U"-bracket	109	1	Press Cable
51	2	Pulley Plate	110	1	Weight Cable
52	1	Center Base	111	3	Large Cable Trap
53	1	Backrest Frame	112	2	20mm x 40mm Inner Cap
54	1	25mm x 40mm Inner Cap	113	1	Press Backrest
55	8	Weight	#	1	User's Manual
56	1	Top Weight	#	1	Exercise Guide
57	1	Weight Pin	#	2	Grease Packet
58	2	Handgrip	#	1	Hex Key
59	1	Leg Bumper			

Note: "#" indicates a non-illustrated part. Specifications are subject to change without notice. See the back cover of the user's manual for information about ordering replacement parts.

# EXPLODED DRAWING A—Model No. WEMSSY2915.0 R0306A

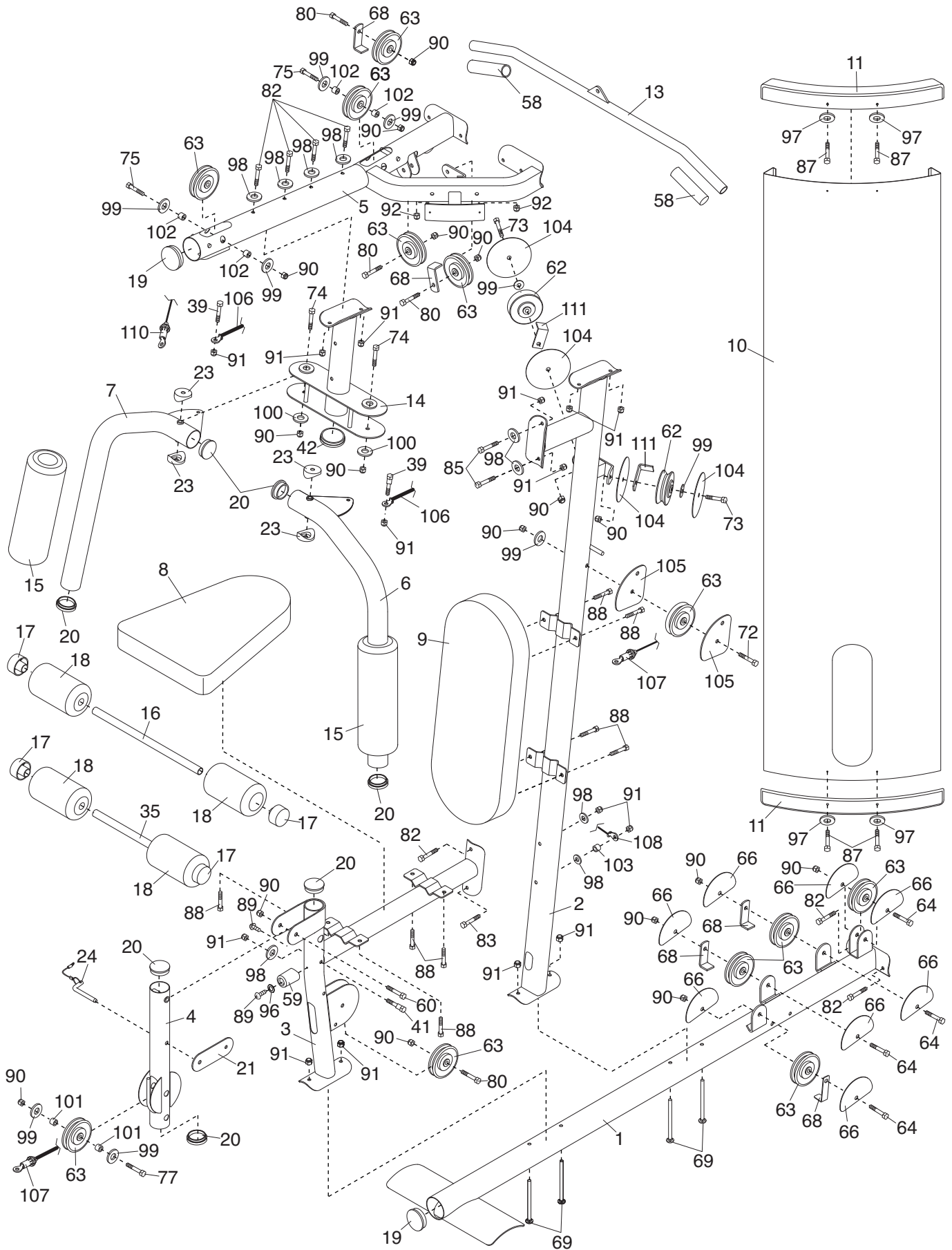

# EXPLODED DRAWING B—Model No. WEMSSY2915.0 R0306A

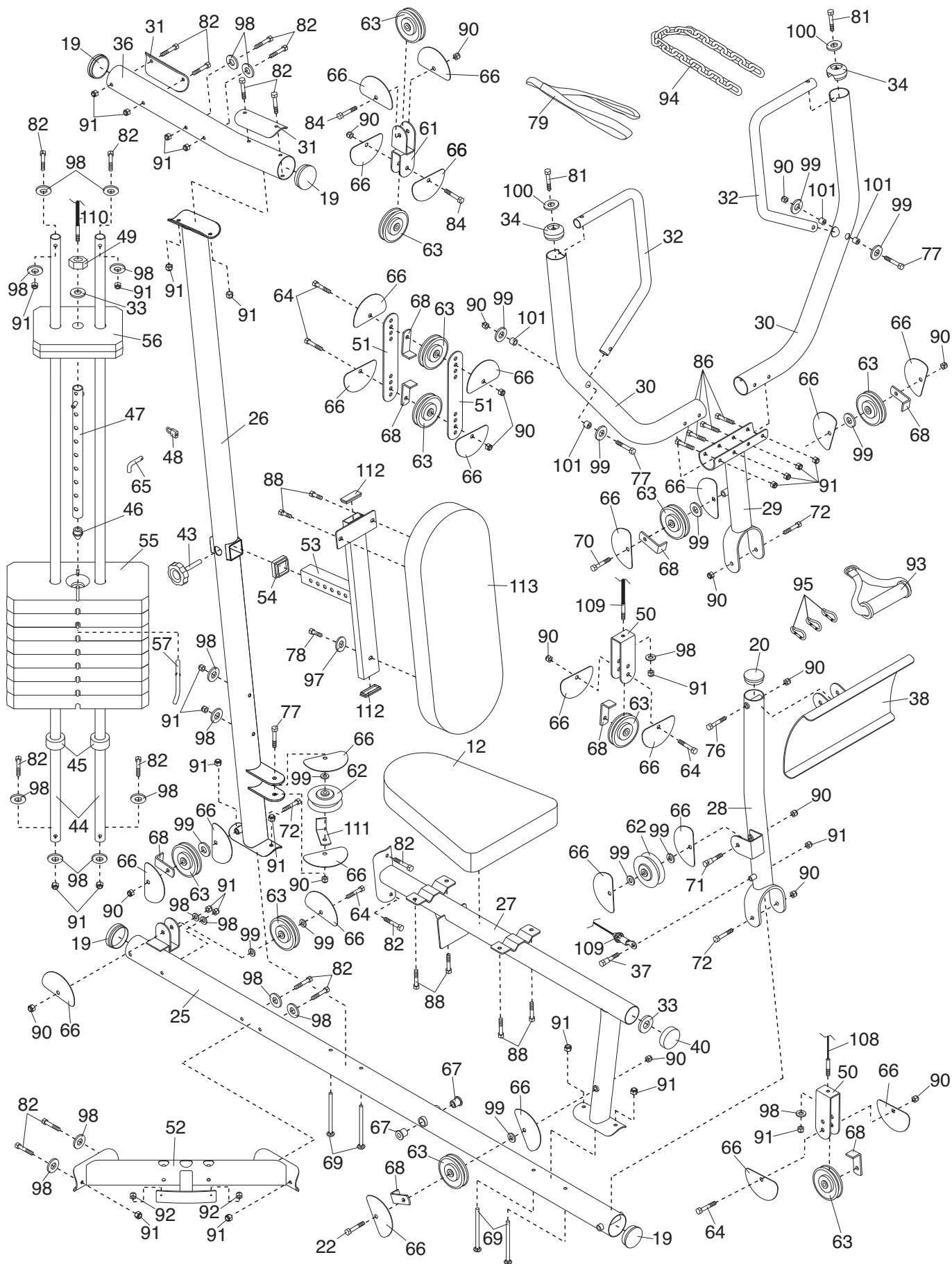

# ADJUSTMENTS

This section explains how to adjust the weight system. See the EXERCISE GUIDELINES on page 29 for important information about how to get the most benefit from your exercise program. Also, see the accompanying exercise guide to see the correct form for each exercise.

Make sure all parts are properly tightened each time the weight system is used. Replace any worn parts immediately. The weight system can be cleaned with a damp cloth and a mild, non-abrasive detergent. Do not use solvents.

## CHANGING THE WEIGHT SETTING

To change the setting of the weight stack, insert the Weight Pin (57) under the desired Weight (55). Insert the Weight Pin so that the bent end touches the weight stack. Turn the bent end down. **Note: Be careful not to scratch yourself when reaching through the hole in the Shroud (10). Do not use the Top Weight (56, not shown) by itself.**

**Note: Due to the cables and pulleys, the amount of resistance at each exercise station may vary from the weight setting. Use the WEIGHT RESISTANCE CHART on page 25 to find the approximate amount of resistance at each weight station.**

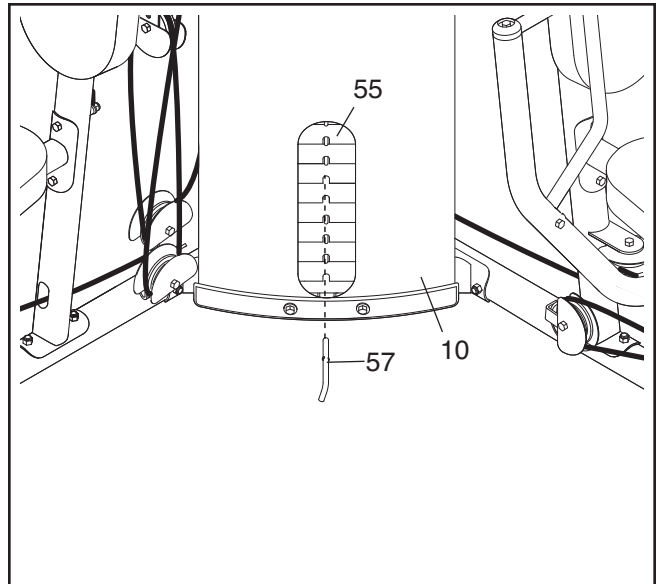

## ATTACHING THE ACCESSORIES TO A PULLEY STATION

Attach the Handle (93) to the Ab Cable (107) at the low pulley station with a Cable Clip (95). For some exercises, the Chain (94) should be attached between the Handle and the Cable with two Cable Clips. **Adjust the length of the Chain between the Handle and the Cable so that the Handle is in the correct starting position for the exercise to be performed.**

The Lat Bar (not shown), the Ab Strap (79), or the Handle (93) can be attached at any pulley station in the same manner. Always engage the Lock Plate (21) when using the low pulley station (see USING THE LOCK PLATE below).

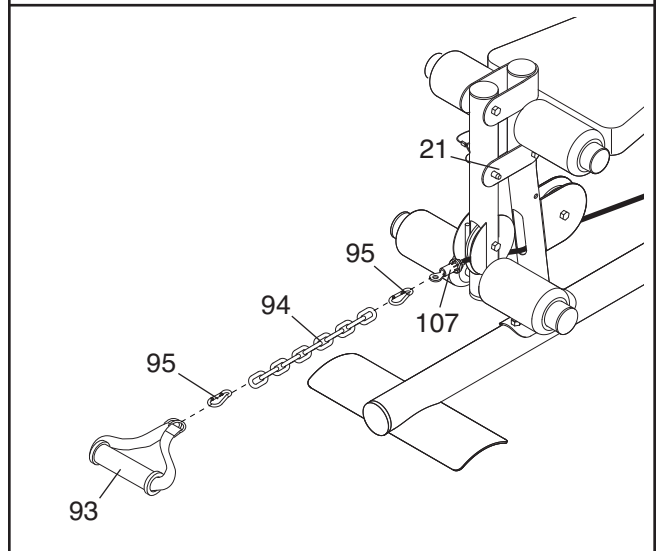

## USING THE LOCK PLATE

When using the low pulley station, engage the Leg Pin (24) into the Leg Lever (4) and the Lock Plate (21).

To use the Leg Lever (4), engage the Leg Pin (24) into the Right Seat Frame (3) and the Lock Plate (21).

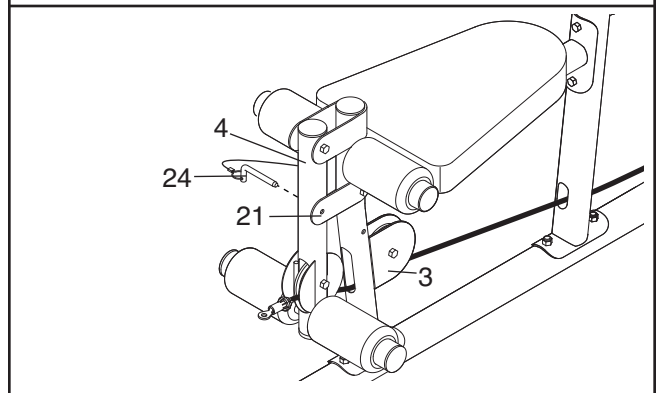

## ADJUSTING THE BACKREST

To adjust the position of the Press Backrest (113), disengaging the Knob (43) from the Left Upright (26) and move the Backrest to the desired position. Reengage the Knob into the Left Upright and the Backrest Frame (53). **Make sure the Knob is fully tightened.**

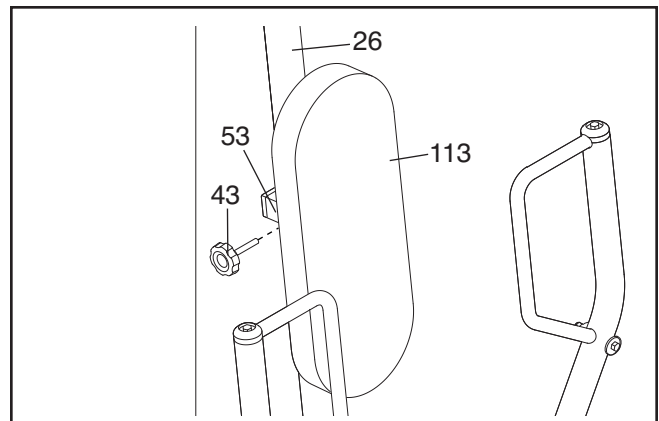

## LOCKING THE WEIGHT STACK

Lock the weight stack by inserting the Lock Pin (65) through a Weight Guide (44) and securing the Lock (48) onto the Lock Pin.

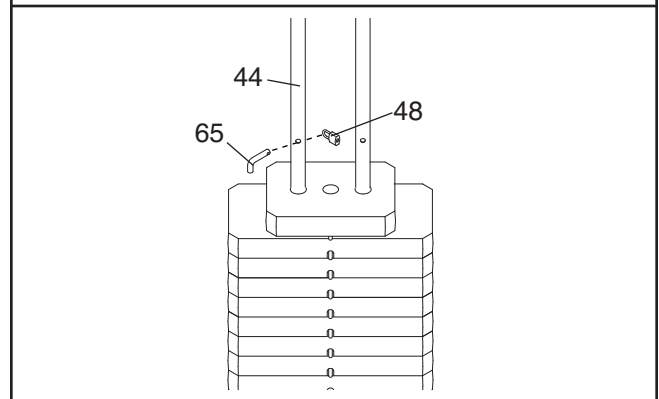

# WEIGHT RESISTANCE CHART

The chart below shows the approximate weight resistance at each exercise station. "Top" refers to the 6 lb. top weight. The other numbers refer to the 12.5 lb. weight plates. Weight resistance shown for the butterfly arm station is for each arm. **Note: The actual resistance at each station may vary due to differences in individual weight plates as well as friction between the cables, pulleys, and weight guides.**

WEIGHT	HIGH PULLEY (lbs.)	BUTTERFLY ARM (lbs.)	PRESS ARM (lbs.)	LEG LEVER (lbs.)	LOW PULLEY (lbs.)	LEG PRESS (lbs.)	AB STATION (lbs.)
<b>Top</b>	10	16	31	11	27	45	19
<b>1</b>	25	30	48	22	35	59	27
<b>2</b>	38	45	81	39	43	84	41
<b>3</b>	54	51	97	49	61	118	60
<b>4</b>	67	60	120	66	71	146	73
<b>5</b>	84	73	138	85	87	162	90
<b>6</b>	97	88	150	94	107	193	100
<b>7</b>	105	93	176	106	120	223	114
<b>8</b>	122	106	214	126	143	248	130

Note: 1 pound = .454 kg



# CABLE DIAGRAMS

The cable diagrams below show the proper routing of the Butterfly Cable (106), the Ab Cable (107), the Short Cable (108), the Press Cable (109), and the Weight Cable (110). Use the diagrams to make sure that the cables and the cable traps have been assembled correctly. If the cables have not been correctly routed, the weight system will not function properly and damage may occur. The numbers show the correct route for each cable. **Make sure that the cable traps do not touch or bind the cables.**

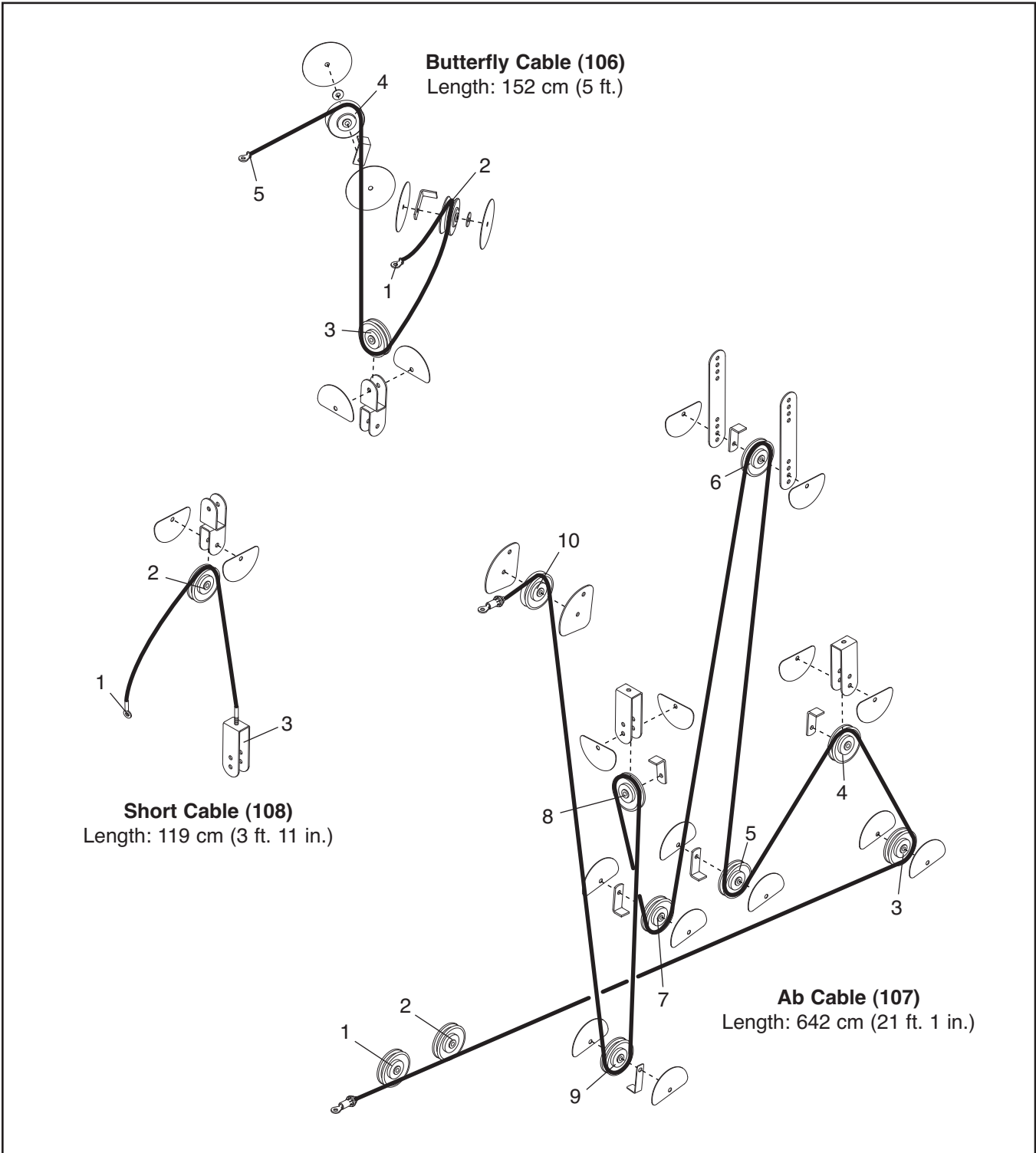

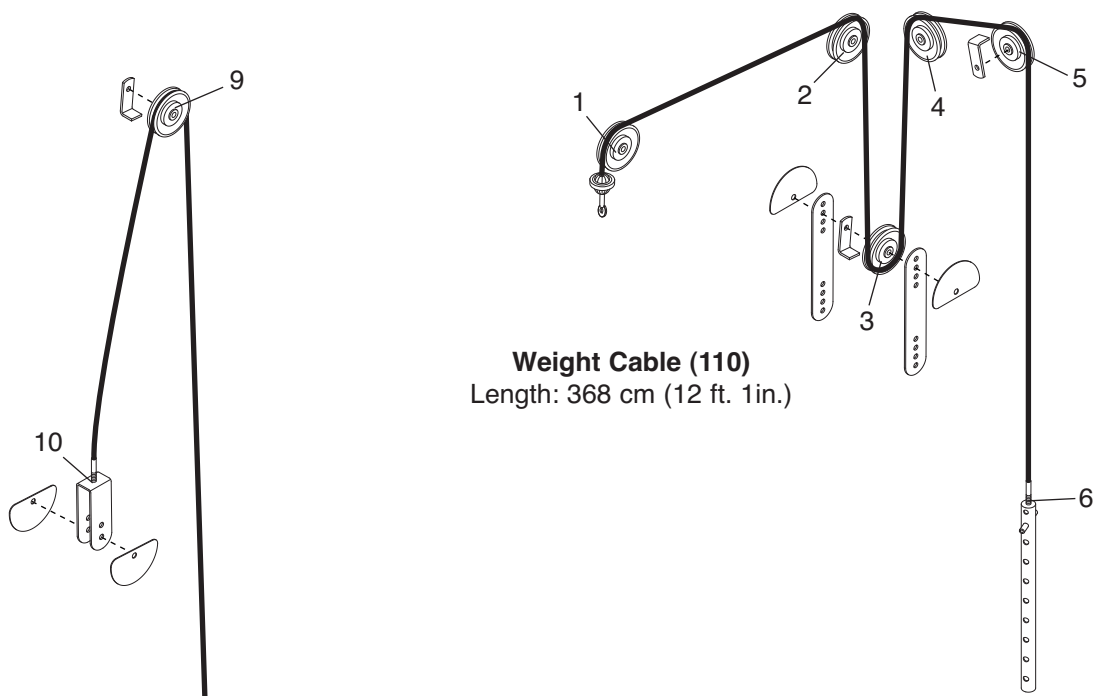

**Weight Cable (110)**  
 Length: 368 cm (12 ft. 1in.)

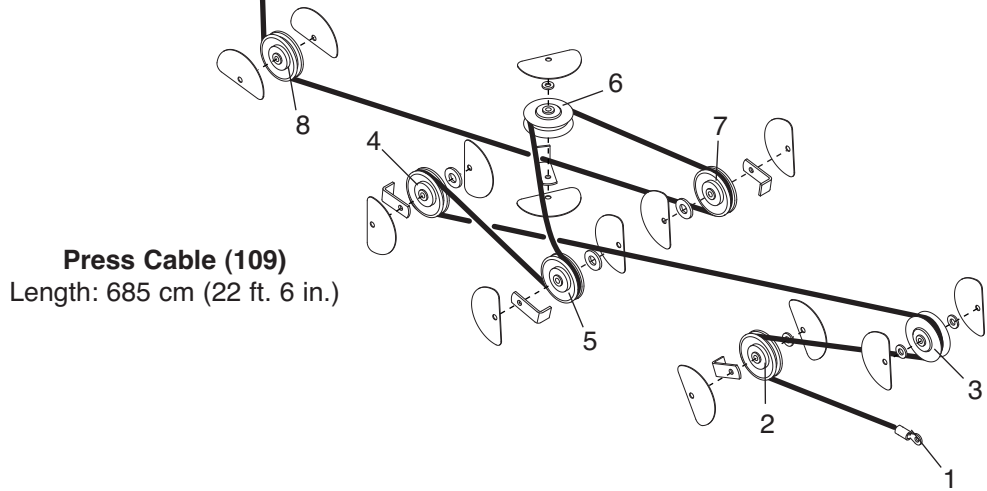

**Press Cable (109)**  
 Length: 685 cm (22 ft. 6 in.)

# MAINTENANCE

Make sure all parts are properly tightened each time the weight system is used. Replace any worn parts immediately. The weight system can be cleaned with a damp cloth and a mild, non-abrasive detergent. Do not use solvents.

## TIGHTENING THE CABLES

Woven cable, the type of cable used on the weight system, can stretch slightly when it is first used. If there is slack in the cables before resistance is felt, the cables should be tightened. To tighten the cables, first insert the weight pin into the middle of the weight stack. Slack can be removed from these cables several ways:

**See drawing 1.** Tighten the M8 Nylon Locknut (91) that connects the end of a cable to a “U”-bracket (50).

**See drawing 1.** Remove the M10 Nylon Locknut (90) and the M10 x 50mm Bolt (64) from the Cable Trap (68), the 90mm Pulley (63), the two Half Finger Guards (66), and a “U”-bracket (50). Reattach the Pulley, Cable Trap, and Finger Guards to the other hole in the “U”-bracket. **Make sure that the Cable Trap and Finger Guards are oriented as shown and that the cable and Pulley move smoothly.**

**See drawing 2.** Remove the M10 Nylon Locknut (90) and the M10 x 50mm Bolt (64) from the Cable Trap (68), the 90mm Pulley (63), the two Half Finger Guards (66), and the two Pulley Plates (51). Reattach the Pulley, Cable Trap, and Finger Guards to the next closer hole to the center of the Pulley Plates. **Make sure that the Cable Trap is oriented to hold the cable in the groove of the Pulley, that the Finger Guards are oriented as shown, and that the Cable and Pulley move smoothly.**

**See drawing 3.** Loosen the M12 Nut (49) on the Weight Cable (110). Tighten the Cable into the Weight Tube (not shown) until the slack is removed from the Cable. Retighten the M12 Nut against the M12 Washer (33).

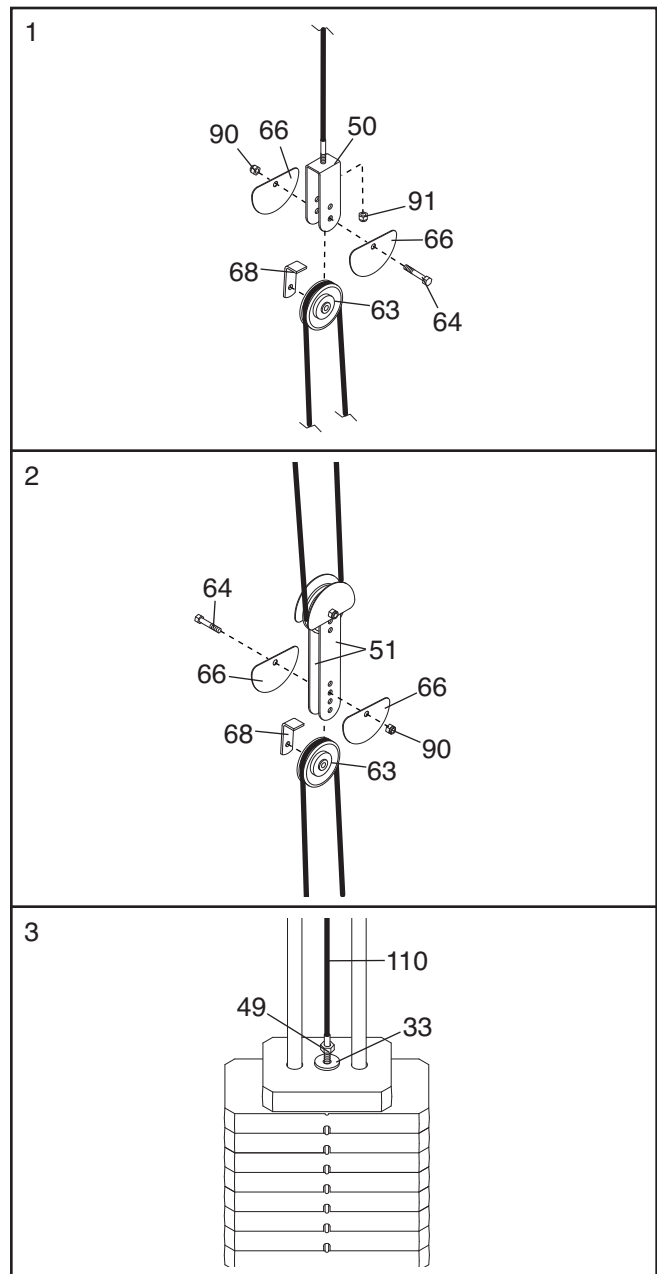

**Do not overtighten the cables. If the cables are overtightened, the top weight will be lifted off the weight stack. If a cable tends to slip off the pulleys often, it may have become twisted. Remove the cable and re-install it. If the cables need to be replaced, see the part ordering information on the back cover of this manual.**

---

# EXERCISE GUIDELINES

## THE FOUR BASIC TYPES OF WORKOUTS

### Muscle Building

To increase the size and strength of your muscles, push them close to their maximum capacity. Your muscles will continually adapt and grow as you progressively increase the intensity of your exercise. You can adjust the intensity level of an individual exercise in two ways:

- by changing the amount of weight used
- by changing the number of repetitions or sets performed. (A “repetition” is one complete cycle of an exercise, such as one sit-up. A “set” is a series of repetitions.)

The proper amount of weight for each exercise depends upon the individual user. You must gauge your limits and select the amount of weight that is right for you. Begin with 3 sets of 8 repetitions for each exercise you perform. Rest for three minutes after each set. When you can complete 3 sets of 12 repetitions without difficulty, increase the amount of weight.

### Toning

You can tone your muscles by pushing them to a moderate percentage of their capacity. Select a moderate amount of weight and increase the number of repetitions in each set. Complete as many sets of 15 to 20 repetitions as possible without discomfort. Rest for one minute after each set. Work your muscles by completing more sets rather than by using high amounts of weight.

### Weight Loss

To lose weight, use a low amount of weight and increase the number of repetitions in each set. Exercise for 20 to 30 minutes, resting for a maximum of 30 seconds between sets.

### Cross Training

Cross training is an efficient way to get a complete and well-balanced fitness program. An example of a balanced program is:

- Plan strength training workouts on Monday, Wednesday, and Friday.
- Plan 20 to 30 minutes of aerobic exercise, such as running on a treadmill or riding on an exercise cycle or an elliptical exerciser, on Tuesday and Thursday.
- Rest from both strength training and aerobic exercise for at least one full day each week to give your body time to regenerate.

The combination of strength training and aerobic exercise will reshape and strengthen your body, plus develop your heart and lungs.

## PERSONALIZING YOUR EXERCISE PROGRAM

Determining the exact length of time for each workout, as well as the number of repetitions or sets completed, is an individual matter. It is important to avoid overdoing it during the first few months of your exercise program. You should progress at your own pace and be sensitive to your body’s signals. If you experience pain or dizziness at any time while exercising, stop immediately and begin cooling down. Find out what is wrong before continuing. Remember that adequate rest and a proper diet are important factors in any exercise program.

### WARMING UP

Begin each workout with 5 to 10 minutes of stretching and light exercise to warm up. Warming up prepares your body for more strenuous exercise by increasing circulation, raising your body temperature and delivering more oxygen to your muscles.

### WORKING OUT

Each workout should include 6 to 10 different exercises. Select exercises for every major muscle group, emphasizing areas that you want to develop most. To give balance and variety to your workouts, vary the exercises from session to session.

Schedule your workouts for the time of day when your energy level is the highest. Each workout should be followed by at least one day of rest. Once you find the schedule that is right for you, stick with it.

### EXERCISE FORM

Maintaining proper form is an essential part of an effective exercise program. This requires moving through the full range of motion for each exercise, and moving only the appropriate parts of the body. Exercising in an uncontrolled manner will leave you feeling exhausted. On the exercise guide accompanying this manual you will find photographs showing the correct form for several exercises, and a list of the muscles affected. See the muscle chart on the next page to find the names of the muscles.

The repetitions in each set should be performed smoothly and without pausing. The exertion stage of each repetition should last about half as long as the return stage. Proper breathing is important. Exhale during the exertion stage of each repetition and inhale during the return stroke. Never hold your breath.

Rest for a short period of time after each set. The ideal resting periods are:

- Rest for three minutes after each set for a muscle building workout.
- Rest for one minute after each set for a toning workout.
- Rest for 30 seconds after each set for a weight loss workout.

Plan to spend the first couple of weeks familiarizing yourself with the equipment and learning the proper form for each exercise.

### COOLING DOWN

End each workout with 5 to 10 minutes of stretching. Include stretches for both your arms and legs. Move

slowly as you stretch and do not bounce. Ease into each stretch gradually and go only as far as you can without strain. Stretching at the end of each workout is an effective way to increase flexibility.

### STAYING MOTIVATED

For motivation, keep a record of each workout. The chart on page 31 of this manual can be photocopied and used to schedule and record your workouts. List the date, the exercises performed, the weight used, and the numbers of sets and repetitions completed. Record your weight and key body measurements at the end of every month. Remember, the key to achieving the greatest results is to make exercise a regular and enjoyable part of your everyday life.

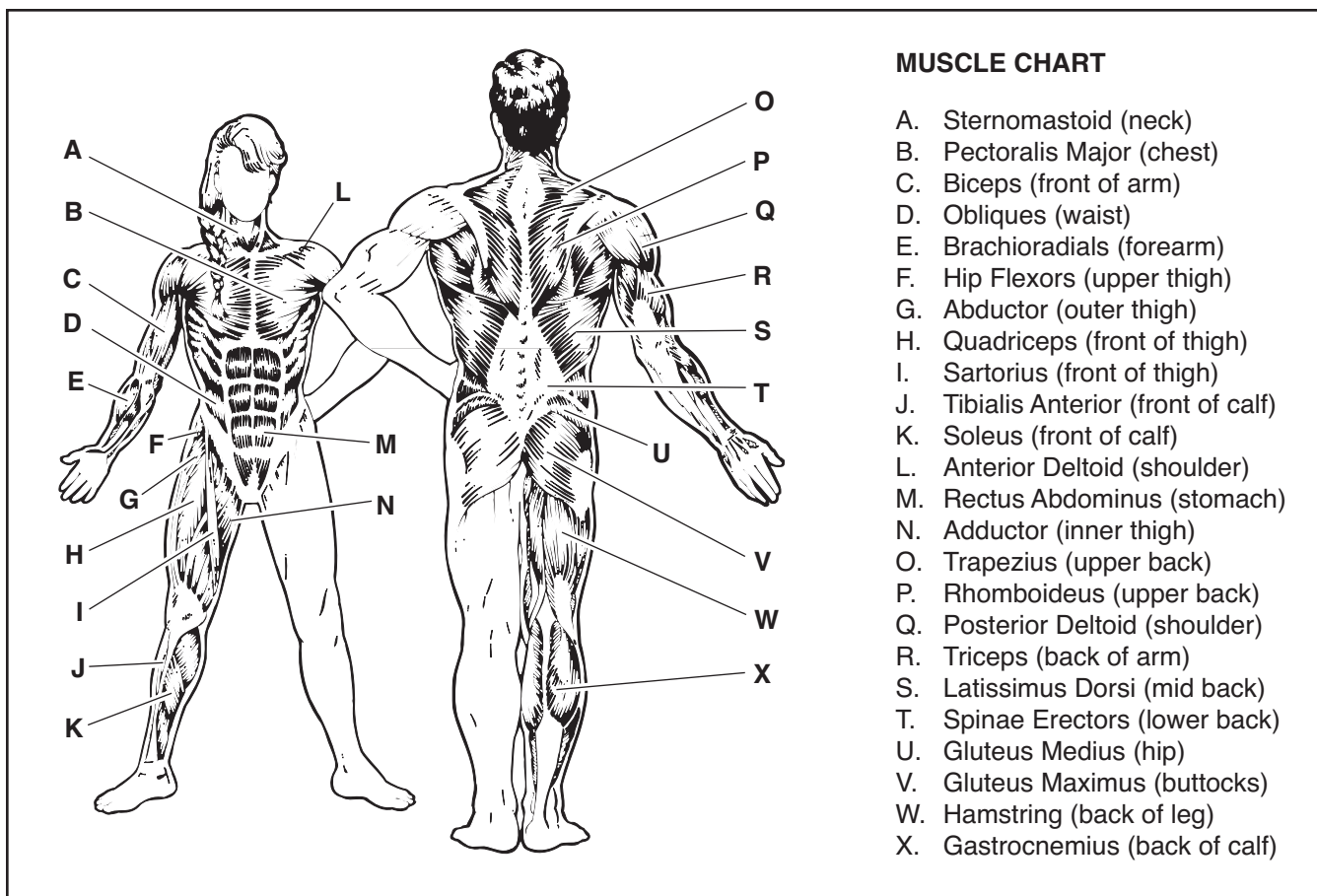

<b>MONDAY</b>	<b>EXERCISE</b>	<b>WEIGHT</b>	<b>SETS</b>	<b>REPS</b>
Date: / /				

**TUESDAY AEROBIC EXERCISE**

Date: / /

<b>WEDNESDAY</b>	<b>EXERCISE</b>	<b>WEIGHT</b>	<b>SETS</b>	<b>REPS</b>
Date: / /				

**THURSDAY AEROBIC EXERCISE**

Date: / /

<b>FRIDAY</b>	<b>EXERCISE</b>	<b>WEIGHT</b>	<b>SETS</b>	<b>REPS</b>
Date: / /				

Make photocopies of this page for scheduling and recording your workouts.

---

# ORDERING REPLACEMENT PARTS

To order replacement parts, please call the telephone number on the warranty card accompanying this manual.

Please provide the following information when ordering replacement parts:

- the MODEL NUMBER of the product (WEMSSY2915.0)
- the NAME of the product (WEIDER PRO 4250 weight system)
- the SERIAL NUMBER of the product (see the front cover of this manual)
- the KEY NUMBER and DESCRIPTION of the part(s) (see the PART LIST and EXPLODED DRAWING in the centre of this manual)