

PRO

9625TM

Model No. WESY96252

Serial No. _____

(Write the serial number in the space above for reference.)

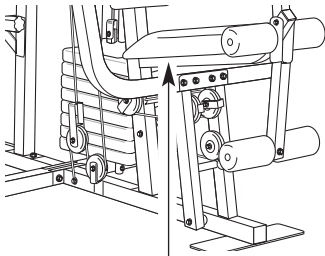

Serial Number Decal

USER'S MANUAL

QUESTIONS?

As a manufacturer, we are committed to providing complete customer satisfaction. If you have questions, or find there are missing or damaged parts, we will guarantee you complete satisfaction through direct assistance from our factory.

TO AVOID UNNECESSARY DELAYS, PLEASE CALL DIRECT TO OUR TOLL-FREE CUSTOMER HOT LINE. The trained technicians on our customer hot line will provide immediate assistance, free of charge to you.

CUSTOMER HOT LINE:

1-888-936-4266

Mon.-Fri., 8 a.m.-6:30 p.m. EST
(excluding holidays)



CAUTION

Read all precautions and instructions in this manual before using this equipment. Save this manual for future reference.

WEIDER[®]

TABLE OF CONTENTS

IMPORTANT PRECAUTIONS2
BEFORE YOU BEGIN3
ASSEMBLY4
ADJUSTMENT19
TROUBLE-SHOOTING AND MAINTENANCE22
LIMITED WARRANTY23
PART IDENTIFICATION CHART	End of Manual
PART LIST	End of Manual
EXPLODED DRAWING	End of Manual
ORDERING REPLACEMENT PARTS	Back Cover

IMPORTANT PRECAUTIONS

WARNING: To reduce the risk of serious injury, read the following important precautions before using the home gym system.

1. It is the responsibility of the owner to ensure that all users of the home gym system are adequately informed of all precautions.
2. Read all instructions in this manual and in the accompanying literature before using the home gym system.
3. If you feel pain or dizziness at any time while exercising, stop immediately and begin cooling down.
4. Use the home gym system only on a level surface. Cover the floor or carpet beneath the home gym system for protection.
5. Inspect and tighten all parts often. Replace any worn parts immediately.
6. Keep small children and pets away from the home gym system at all times.
7. The home gym system is designed to be used by only one person at a time.
8. Keep hands and feet away from moving parts.
9. Always wear athletic shoes for foot protection when exercising.
10. Always stand on a foot plate when performing an exercise that could cause the home gym system to tip.
11. Never release the press arm, butterfly arms, squat arm, leg lever, lat bar, or nylon strap while weights are raised. The weights will fall with great force.
12. Make sure that the cables remain on the pulleys at all times. If the cables bind while you are exercising, stop immediately and make sure that the cables are on all of the pulleys.
13. Always disconnect the lat bar from the home gym system when performing an exercise that does not use the lat bar.
14. The home gym system is intended for home use only. Do not use the home gym system in a commercial, rental, or institutional setting.

WARNING: Before beginning this or any exercise program, consult your physician. This is especially important for persons over the age of 35 or persons with pre-existing health problems. Read all instructions before using. ICON assumes no responsibility for personal injury or property damage sustained by or through the use of this product.

BEFORE YOU BEGIN

Thank you for selecting the WEIDER® PRO 9625 Home Gym System. The versatile PRO 9625 is designed to develop every major muscle group of the body. Whether your goal is a shapely figure, dramatic muscle size and strength, or a healthier cardiovascular system, the PRO 9625 will help you to achieve the specific results you want.

For your benefit, read this manual carefully before using the WEIDER® PRO 9625 Home Gym System. If you have additional questions, please call our

Customer Service Department toll-free at 1-888-936-4266, Mon.–Fri., 8 a.m.–6:30 p.m. EST (excluding holidays). To help us assist you, please note the product model number and serial number before calling. The model number is WESY96252. The serial number can be found on a decal attached to the WEIDER® PRO 9625 (see the front cover of this manual).

Before reading further, please review the drawing below and familiarize yourself with the parts that are labeled.

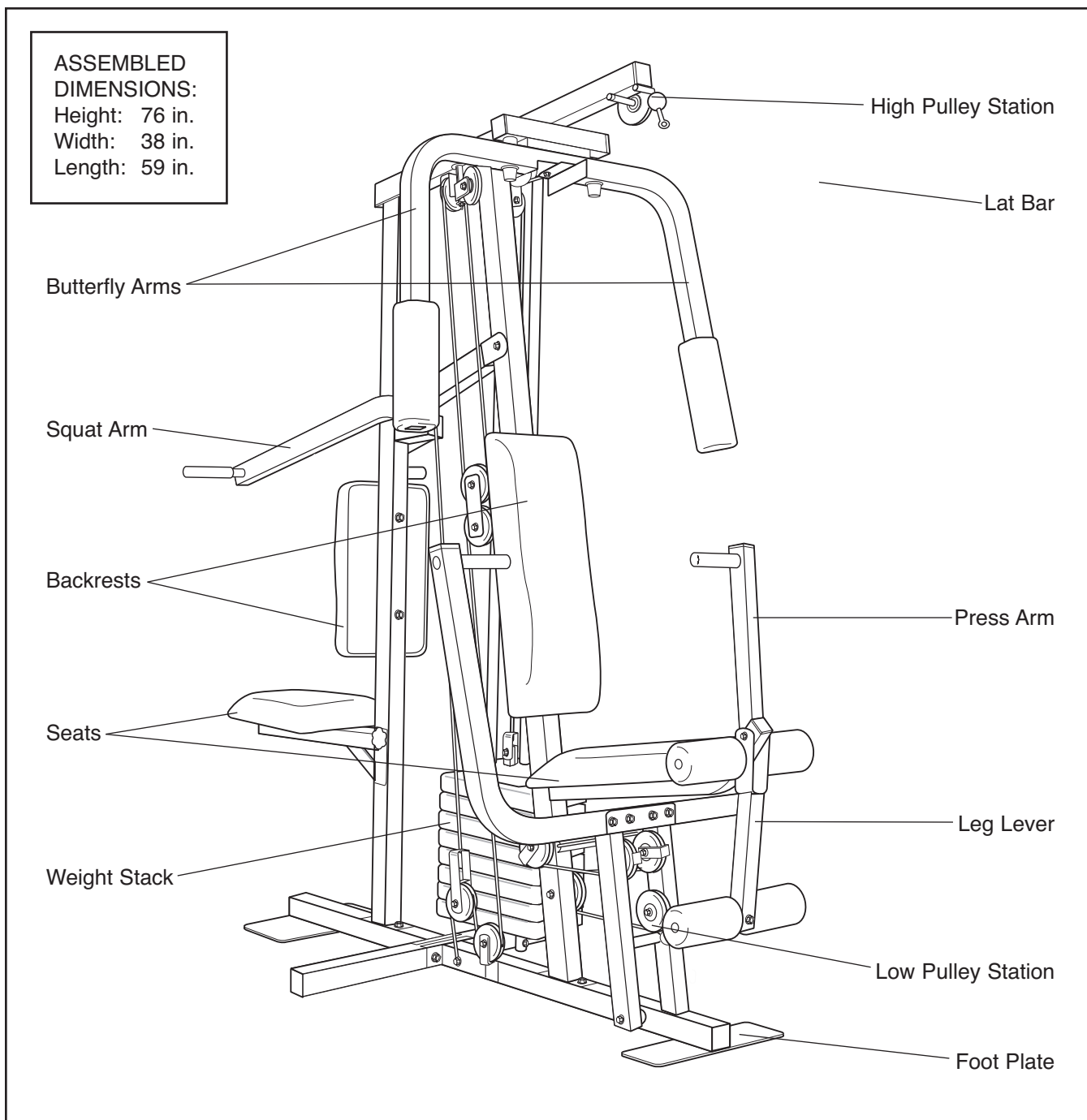



ASSEMBLY

Before beginning assembly, carefully read the following information and instructions:

- Place all parts of the home gym system in a cleared area and remove the packing materials; do not dispose of the packing materials until assembly is completed.
- The assembly is divided into four stages: 1) frame assembly, 2) press, squat, and butterfly arm assembly, 3) cable and pulley assembly, and 4) seat and backrest assembly. The hardware for each stage is packaged separately.
- Wait until you begin each assembly stage to open that parts bag.
- For help identifying the small parts used in assembly, **use the PART IDENTIFICATION CHART located in the center of this manual.**
Note: Some small parts may have been pre-attached for shipping. If a part is not in the parts bag, check to see if it has been pre-attached.

- As you assemble the home gym system, be sure that all parts are oriented as shown in the drawings.
- Tighten all parts as you assemble them, unless instructed to do otherwise.

THE FOLLOWING TOOLS (NOT INCLUDED) ARE REQUIRED FOR ASSEMBLY:

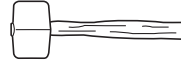
- **Two (2) adjustable wrenches** 
- **One (1) standard screwdriver** 
- **One (1) phillips screwdriver** 
- **One (1) rubber mallet** 
- **Lubricant, such as grease or petroleum jelly, and soapy water will also be needed.**

Assembly will be more convenient if you have the following tools: A socket set, a set of open-end or closed-end wrenches, or a set of ratchet wrenches.

FRAME ASSEMBLY

1. **Before beginning assembly, be sure that you have read and understand the information in the box above.**

Press a 2" Square Inner Cap (27) into the end of the Rear Base (51). Press a 2" Square Cover Cap (78) onto each end of the Stabilizer (5).

Insert two 5/16" x 2 1/2" Carriage Bolts (1) up through the Rear Base (51). Insert two 5/16" x 2 3/4" Bolts (11) through the Rear Base and Stabilizer (5) as shown.

2. Press a 2" Square Inner Cap (27) into the end of the Front Base (4).

Insert two 5/16" x 2 1/2" Carriage Bolts (1) up through the Front Base (4). Slide the Front Base onto the two 5/16" x 2 3/4" Bolts (11) in the Rear Base (51) and Stabilizer (5). Hand-tighten two 5/16" Nylon Locknuts (3) onto the Carriage Bolts. **Do not tighten the Nylon Locknuts yet.**

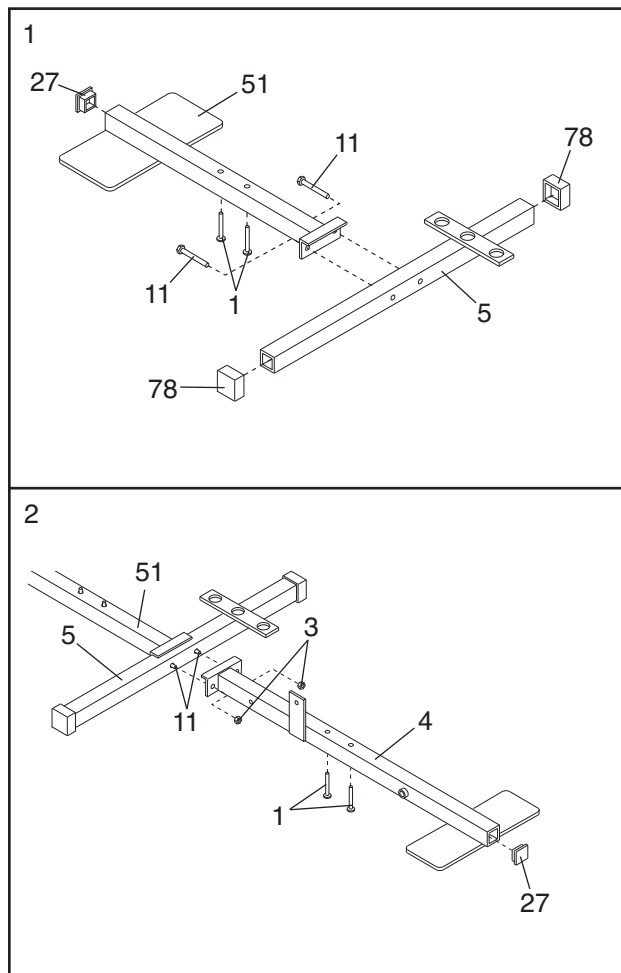

3. Press a 2" Square Inner Cap (27) into the Rear Upright (56).

Attach a Rubber Bumper (90) to the Rear Upright (56) with a #8 x 1/2" Tap Screw (89).

Slide the Rear Upright (56) onto the 5/16" x 2 1/2" Carriage Bolts (1) in the Rear Base (51). Hand tighten a 5/16" Nylon Locknut (3) onto each Carriage Bolt. **The high side of the bracket on the Rear Upright must be on the side shown. Do not tighten the Nylon Locknuts yet.**

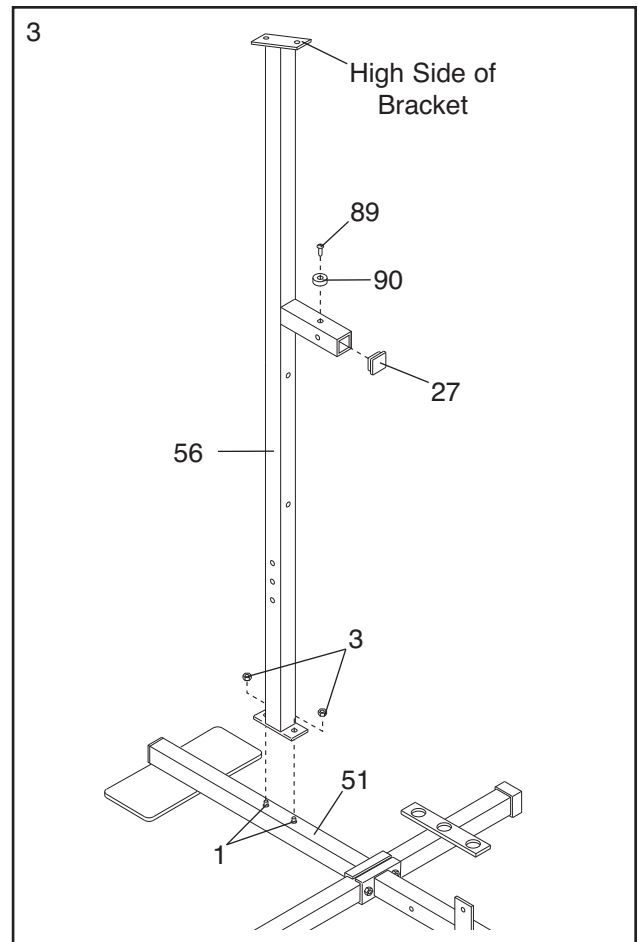

4. Press a 1" Square Inner Cap (65) into the Front Upright (42).

Slide the Front Upright (42) onto the 5/16" x 2 1/2" Carriage Bolts (1) in the Front Base (4). Hand tighten a 5/16" Nylon Locknut (3) onto each Carriage Bolt. **Do not tighten the Nylon Locknuts yet.**

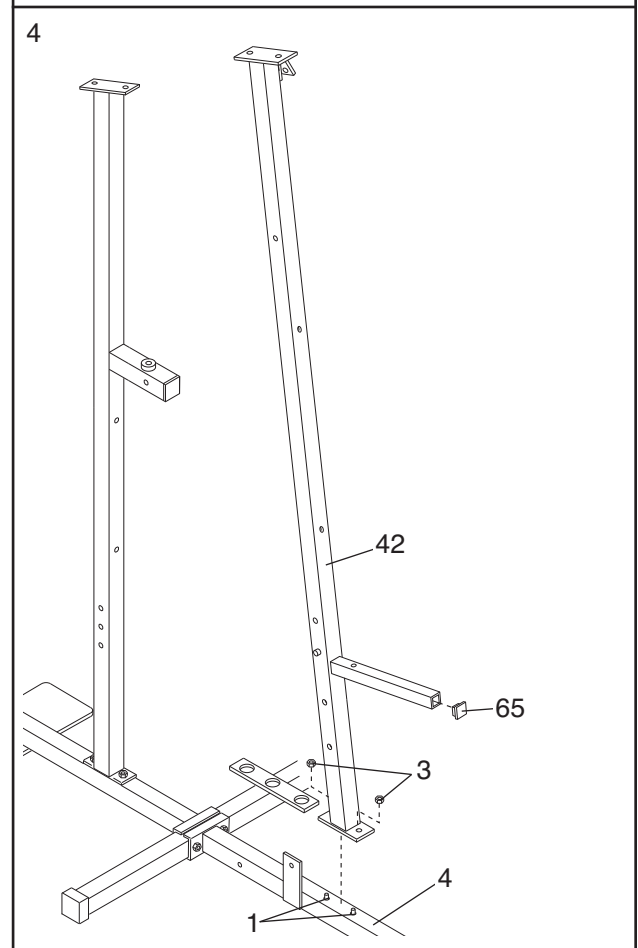

- Set two Weight Bumpers (19) onto the bracket on the Stabilizer (5). Insert both Weight Guides through the Weight Bumpers and the bracket on the Stabilizer. **Be sure that the drilled holes in the Weight Guides are at the top, as shown.** Press a 1" Round Cover Cap (70) onto the bottom of each Weight Guide (62).

Slide eight Weights (25) on the Weight Guides (62). **Be sure that all of the Weights are turned so the pin grooves are on the same side.**

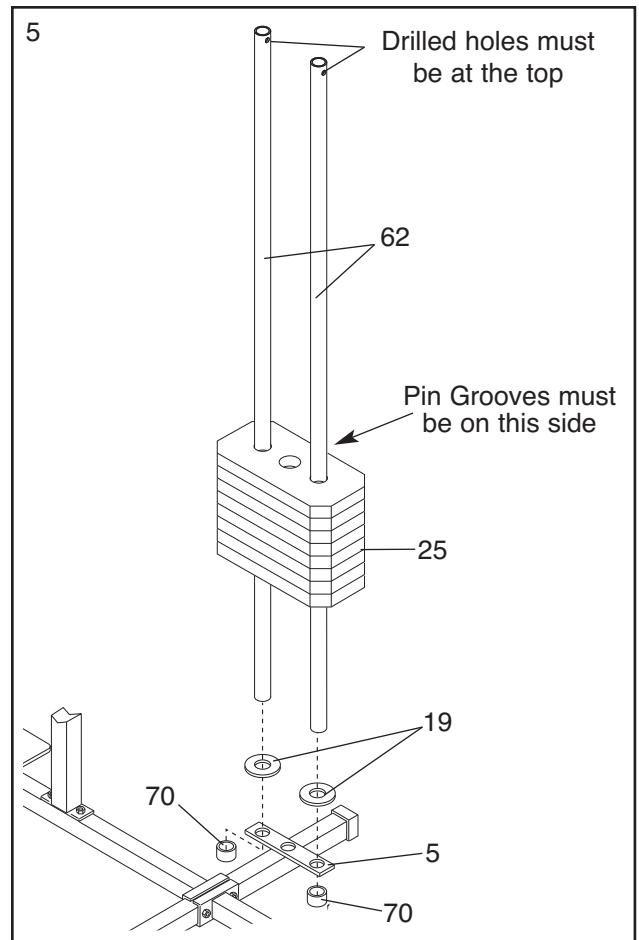

- Press the Weight Tube Bumper (64) into the end of the Weight Tube (63). Insert the Weight Tube into the stack of Weights (25). Be sure that the pins on the Weight Tube are resting in the pin grooves in the upper Weight.

Lubricate the insides of the holes in the Top Weight (76). Slide the Top Weight onto the Weight Guides (62) and set it on the stack of Weights (25).

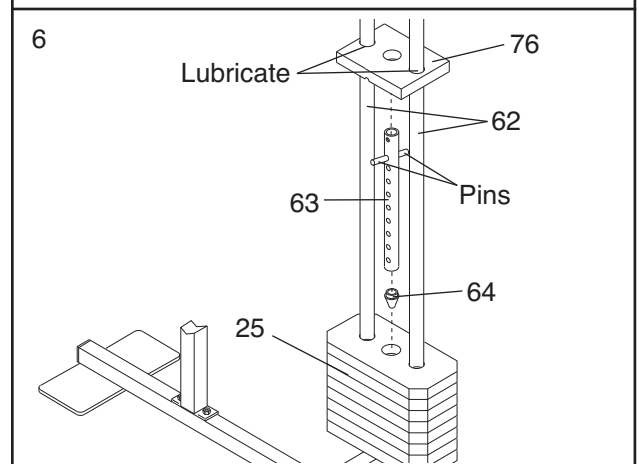

- Press a 2" Square Inner Cap (27) into each end of the Top Frame (55). Press a 1 3/4" Square Inner Cap (44) into each end of the crossbar on the Top Frame. Press two 1" Round Inner Caps (49) into the top of the crossbar.

Attach the Top Frame (55) to the Front Upright (42) and the Rear Upright (56) with four 5/16" x 2 3/4" Bolts (11), four 5/16" Flat Washers (8), and four 5/16" Nylon Locknuts (3).

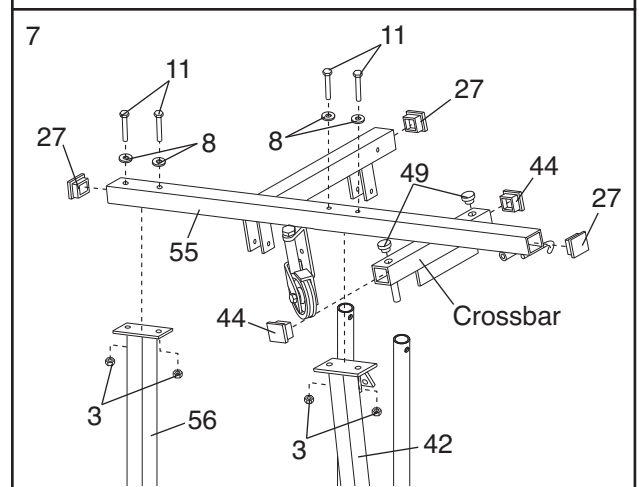

- Attach the upper ends of the Weight Guides (62) to the Top Frame (55) with the 5/16" x 6" Bolt (60), two 1/2" x 3/4" Spacers (61), and a 5/16" Nylon Locknut (3).

Tighten all Nylon Locknuts used in steps 2 through 8.

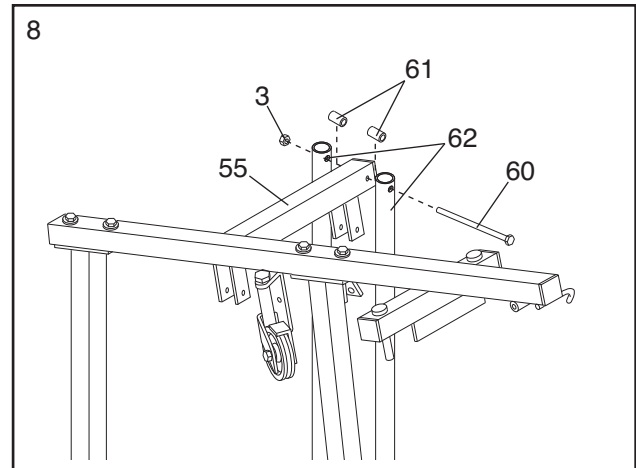

- Press a 1" x 7/8" Plastic Bushing (75) onto each welded spacer on the Press Frame (17). Slide the Press Frame into place on the Front Base (4). **Note: This will be a tight fit. The Plastic Bushings should fit onto each end of the indicated tube in the Base. Be sure that the indicated holes are on the side shown.**

Lubricate the 3/8" x 8" Bolt (59). Attach the Press Frame (17) to the Front Base (4) with the 3/8" x 8" Bolt and a 3/8" Nylon Locknut (21).

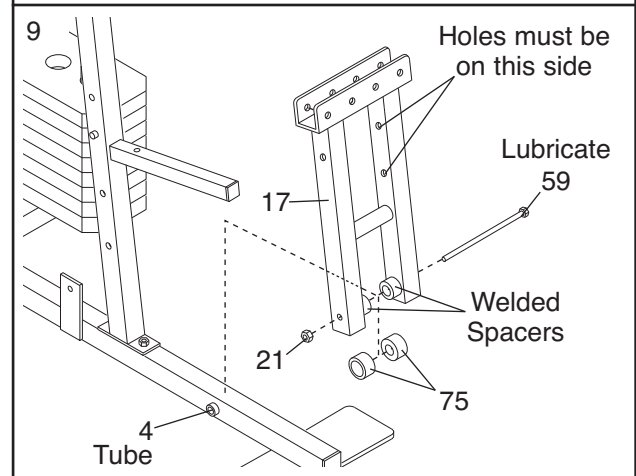

- Press a 1 3/4" Square Inner Cap (44) into the top of a Press Arm (46). Press a 1" Round Inner Cap (49) into the side of the Press Arm. Attach the Press Arm to one side of the Press Frame (17) with two 5/16" x 2 1/2" Bolts (22) and two 5/16" Nylon Locknuts (3).

Assemble the other Press Arm (46) in the same manner.

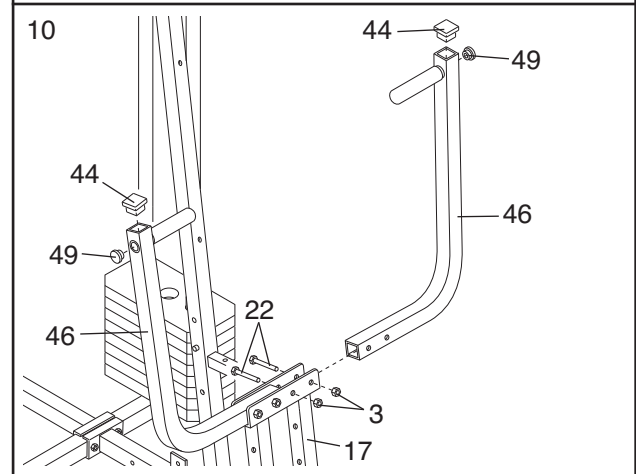

- Identify the Right Arm (48) and the Left Arm (47). Note the position of the welded bracket on each Arm. **Arm identification is very important for step 12.**

Attach a "V"-Pulley (6) and a Long Cable Trap (50) to the Right Arm (48) with a 3/8" x 2 1/2" Bolt (7) and a 3/8" Nylon Locknut (21).

Attach a "V"-Pulley (6) and a Long Cable Trap (50) to the Left Arm (47) with a 3/8" x 2 1/2" Bolt (7) and a 3/8" Nylon Locknut (21).

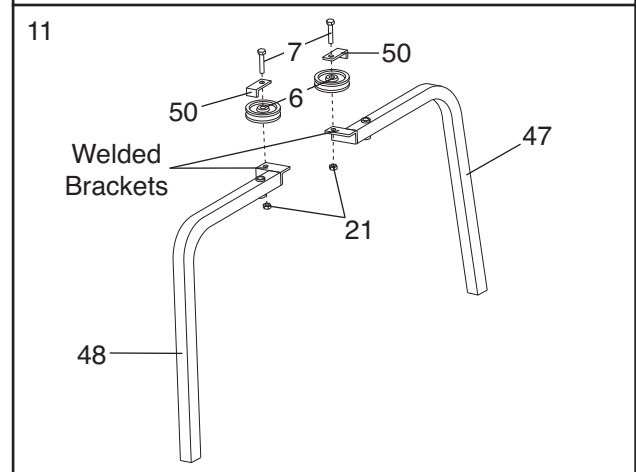

12. Lubricate both axles on the Top Frame (55).

Slide the Right Arm (48) onto the right axle.
Note: Be careful not to confuse the Right Arm with the Left Arm (47); refer to step 11 to identify the Right Arm. Be sure that the upper end of the Right Arm is behind the indicated bracket on the Top Frame (55).

Tap two 1" Retainers (69) and a 1" Round Cover Cap (70) onto the right axle. **Be sure that the teeth on the Retainers bend toward the Cover Cap, as shown in the inset drawing.**

Attach the Left Arm (47) in the same manner.

Press 1 3/4" Square Inner Caps (44) into the lower ends of the Right and Left Arms (47, 48). Wet the lower end of each Arm with soapy water. Slide a 10" Pad (45) onto the lower end of each Arm.

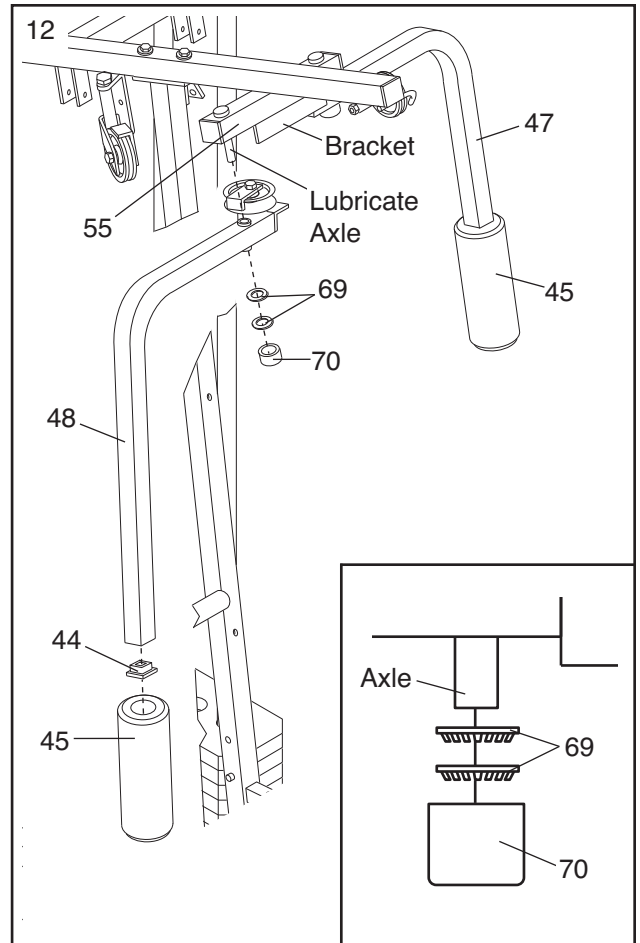

13. Press two 1" x 2" Inner Caps (83) into the indicated end of the Squat Arm (79).

Lubricate a 3/8" x 3 1/4" Bolt (85). Attach the Squat Arm (79) to the Front Upright (42) with the 3/8" x 3 1/4" Bolt and a 3/8" Nylon Locknut (21).

Attach a Handle (92) to one side of the Squat Arm (79) with a 5/16" x 2 1/2" Bolt (22), two 5/16" Flat Washers (8), a 1/2" x 17/32" Spacer (94), and a 5/16" Nylon Locknut (3).

Attach the other Handle (92) to the other side of the Squat Arm (79) in the same manner.

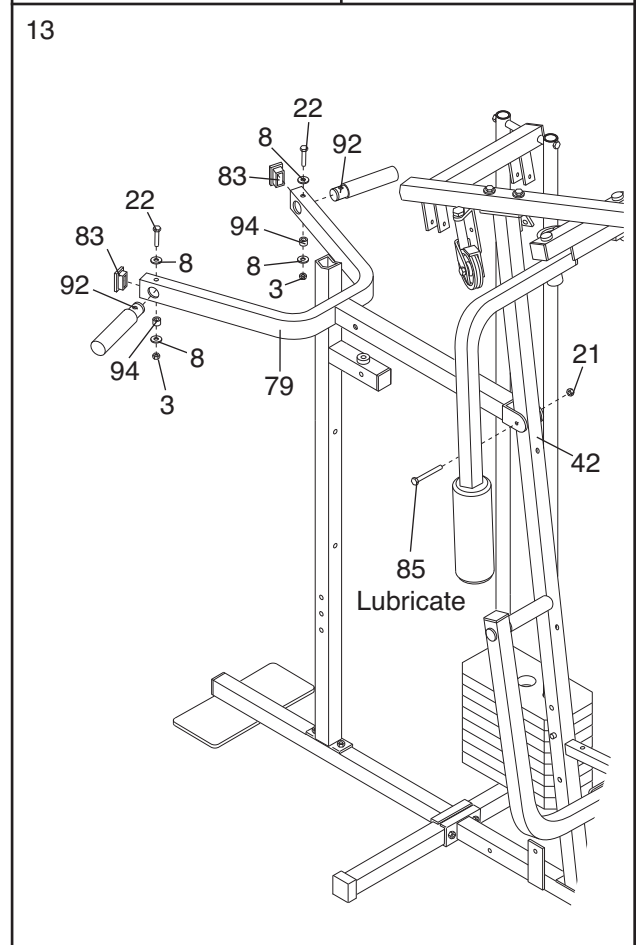

14. During steps 15 through 36, refer to the CABLE DIAGRAM attached to the PART ID Chart to verify proper cable routing. Before beginning this section, identify the Long Cable (86), the Medium Cable (23), and the Short Cable (58) by comparing the lengths and ends of the cables.

IMPORTANT: While assembling the cables, do not overtighten the bolts and nuts securing the pulleys. The pulleys must be able to turn freely.

15. **Locate the Medium Cable (23).** Wrap the Medium Cable around a 3 1/2" Pulley (15). Attach the Pulley to the Top Frame (55) with a 3/8" x 3 3/4" Bolt (71) and a 3/8" Nylon Locknut (21). **Be sure that the end of the Cable with the ball is on the indicated side of the Pulley and that the Cable is between the Pulley and the hook.**

16. Wrap the Medium Cable (23) around a "V"-Pulley (6). Attach the "V"-Pulley and a Long Cable Trap (50) to the indicated bracket on the Front Upright (42) with a 3/8" x 2 1/2" Bolt (7) and a 3/8" Nylon Locknut (21). **Be sure that the Long Cable Trap is positioned to hold the Cable in place.**

17. Route the Medium Cable (23) around the "V"-Pulley (6) on the Left Arm (47). **Be sure that the Cable is in the groove of the Pulley and that the Long Cable Trap (50) is positioned to hold the Cable in place.** Tighten the 3/8" x 2 1/2" Bolt (7) and the 3/8" Nylon Locknut (not shown).

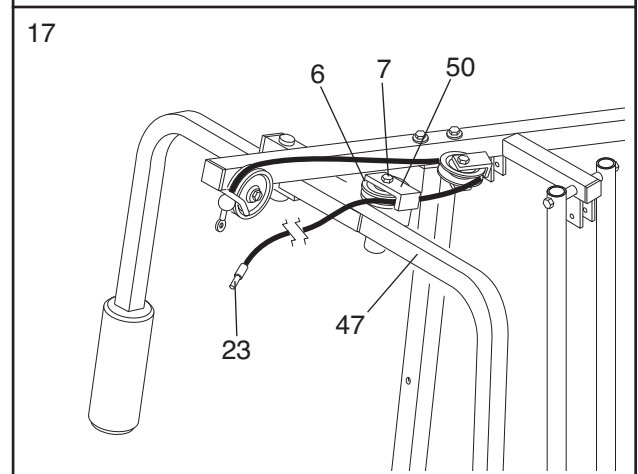
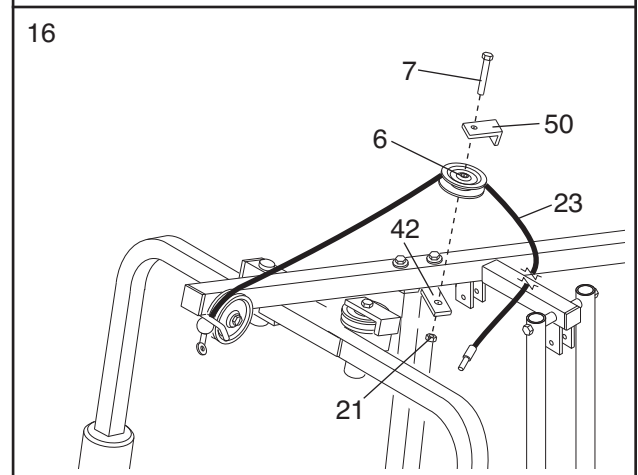
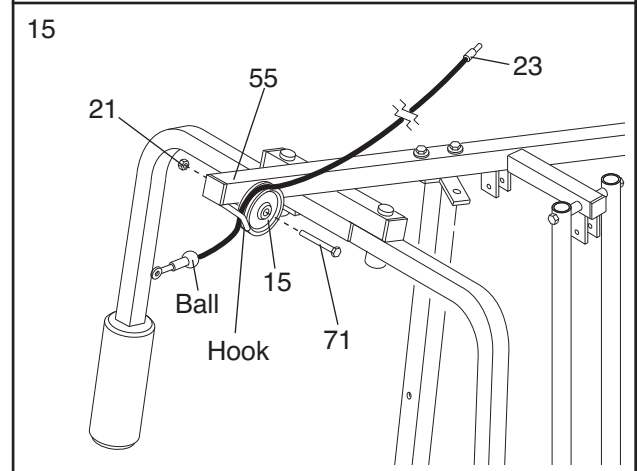
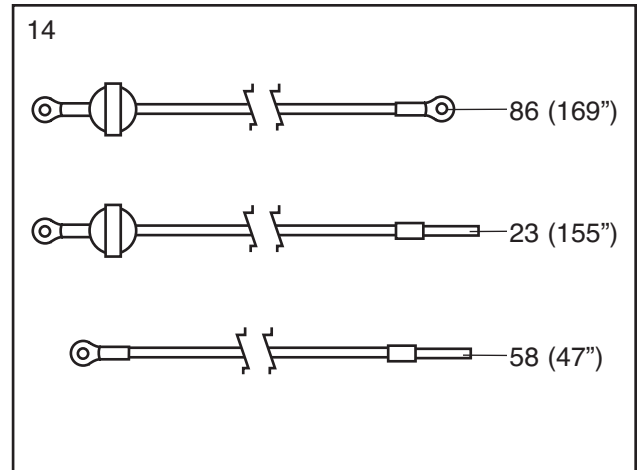

18. Route the Medium Cable (23) around the “V”-Pulley (6) on the Right Arm (48). **Be sure that the Cable is in the groove of the “V”-Pulley and that the Long Cable Trap (50) is turned to hold the Cable in place.** Tighten the 3/8” x 2 1/2” Bolt (7) and the 3/8” Nylon Locknut (not shown).

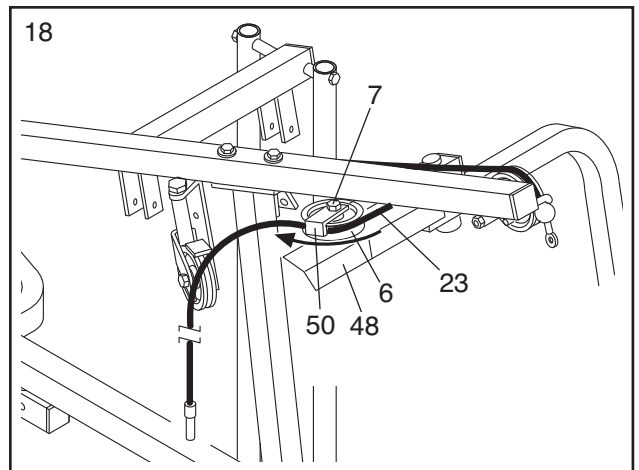

19. Route the Medium Cable (23) around the 3 1/2” Pulley (15) attached to the Pulley Bracket (20). **Be sure that the Cable is in the groove of the Pulley and that the Cable Trap (66) is turned to hold the Cable in place.** Tighten the 3/8” x 2” Bolt (12) and the 3/8” Nylon Locknut (not shown).

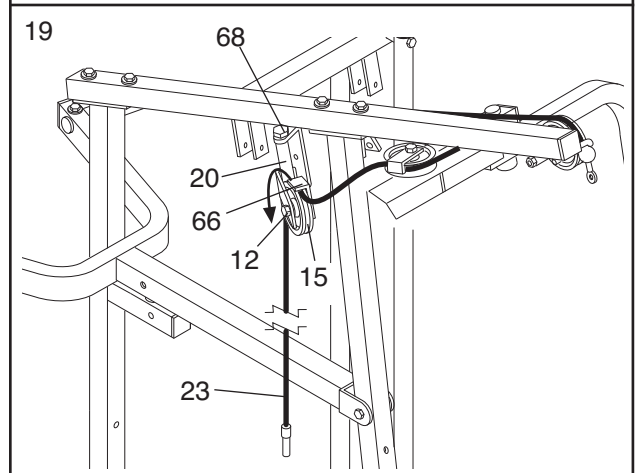

Be sure that the 5/16” x 5” Bolt (68) is properly tightened and that the Pulley Bracket (20) can move freely.

20. Route the Medium Cable (23) around one of the 3 1/2” Pulleys (15) attached to the “I” Plates (81). **Be sure that the Cable is in the groove of the Pulley and that the Cable and Pulley move smoothly.**

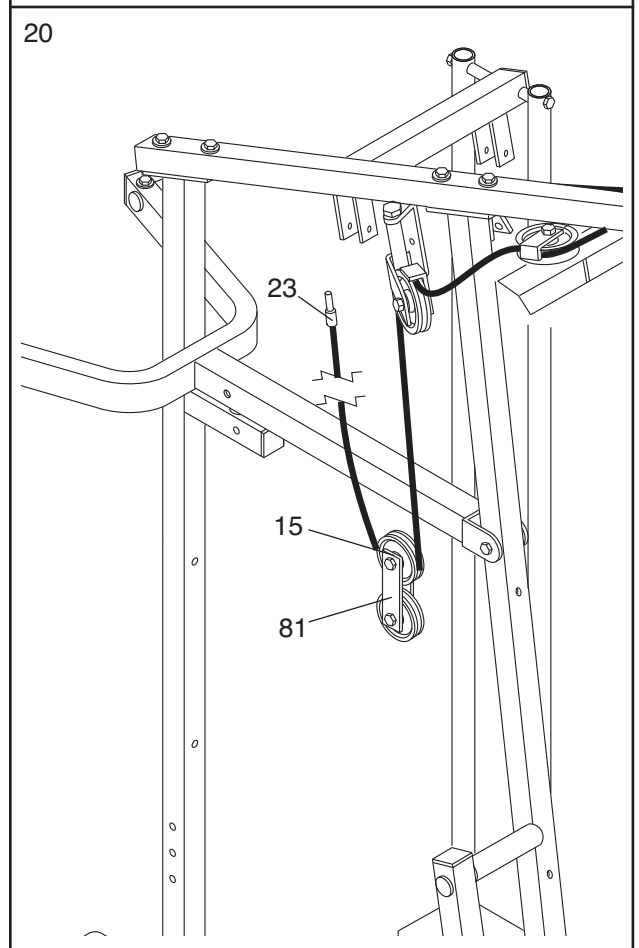

CABLE ASSEMBLY

21. Wrap the Medium Cable (23) around a 3 1/2" Pulley (15). Attach the Pulley to the Top Frame (55) with a 3/8" x 1 3/4" Bolt (87) and a 3/8" Nylon Locknut (21).

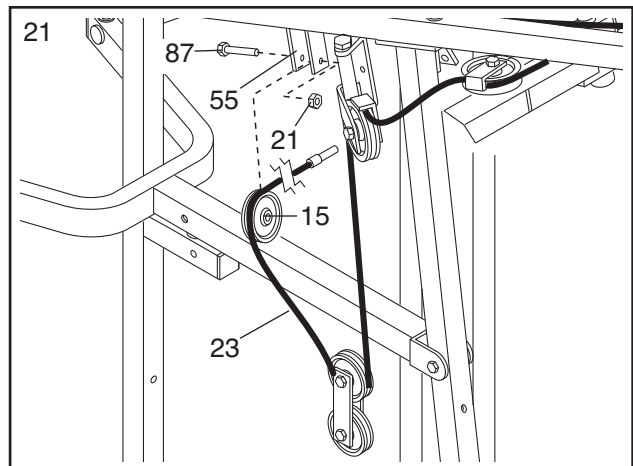

22. Wrap the Medium Cable (23) around a 3 1/2" Pulley (15). Attach the Pulley to the Top Frame (55) with a 3/8" x 1 3/4" Bolt (87) and a 3/8" Nylon Locknut (21).

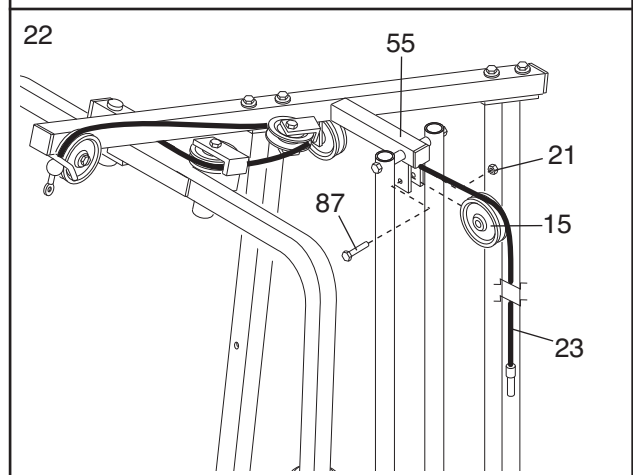

23. Attach the Medium Cable (23) to the Small "U"-Bracket (67) with a 1/4" Nylon Locknut (2) and a 1/4" Flat Washer (10). **Do not completely tighten the Nylon Locknut. It should be threaded onto the end of the Cable only a couple of turns, as shown in the inset drawing.**

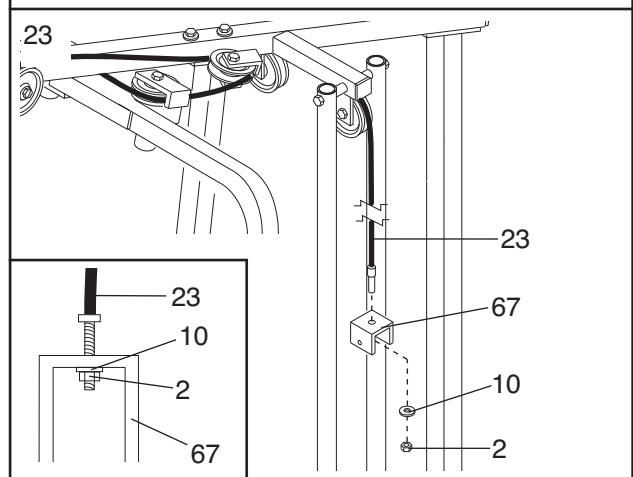

24. **Locate the Short Cable (58).** Attach the Short Cable to the Rear Upright (56) with a 5/16" x 3" Bolt (93), a 5/16" Flat Washer (8), and two 5/16" Nylon Jam Nuts (84). **The end of the Cable must be between the two Nylon Jam Nuts and there must be enough room between the Nylon Jam Nuts for the end of the Cable to pivot.**

Wrap the Short Cable (58) around a 3 1/2" Pulley (15). Attach the Pulley and a Cable Trap (66) to the Squat Arm (79) with a 3/8" x 3 3/4" Bolt (71), a 3/8" Flat Washer (9), and a 3/8" Nylon Lock Nut (21). **The Cable Trap must be turned to hold the Cable in place.**

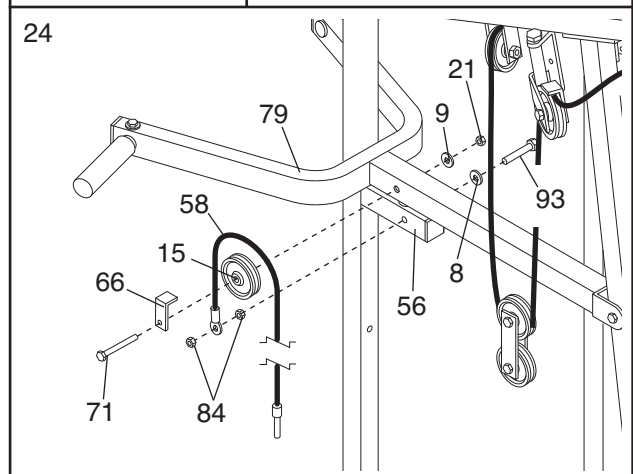

25. Attach the end of the Short Cable (58) to the Long "U"-Bracket (57) with a 1/4" Nylon Locknut (2) and a 1/4" Flat Washer (10). **Do not completely tighten the Nylon Locknut. It should be threaded onto the end of the Cable so only a couple of threads are showing above the nut, as shown in the inset drawing.**

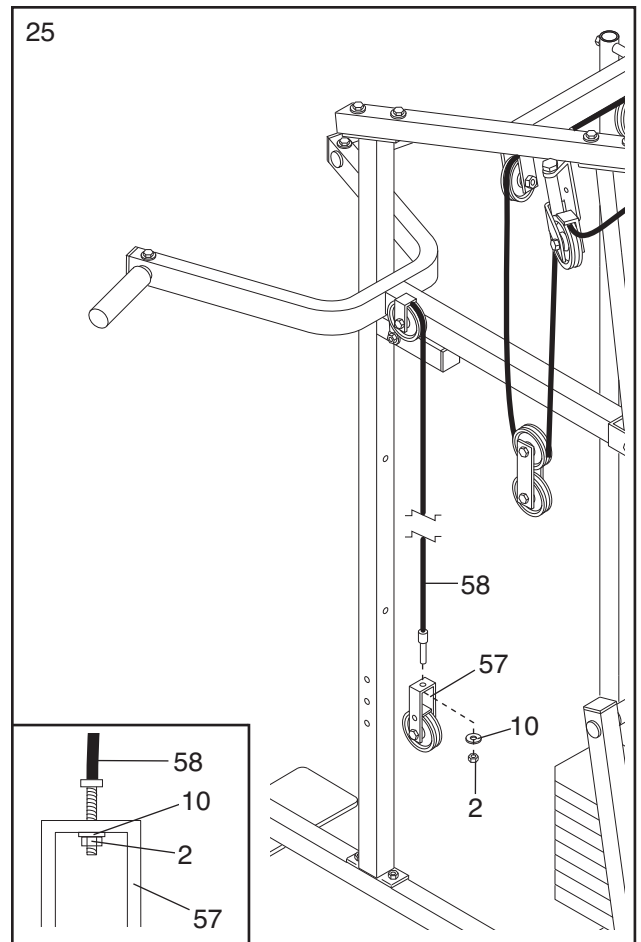

26. Attach the 3 1/2" Low Pulley (88) and the 5/8" x 9/16" Spacer (73) to the indicated hole in the Press Frame (17) with a 3/8" x 3 3/4" Bolt (71), a 3/8" Flat Washer (9), and a 3/8" Nylon Locknut (21). **Do not tighten the 3/8" Nylon Locknut (21) yet. Be sure that the 3/8" x 3 3/4" Bolt (71), the 3/8" Flat Washer (9), the 5/8" x 9/16" Spacer (73), the 3 1/2" Low Pulley (88), and the 3/8" Nylon Locknut (21) are oriented as shown.**

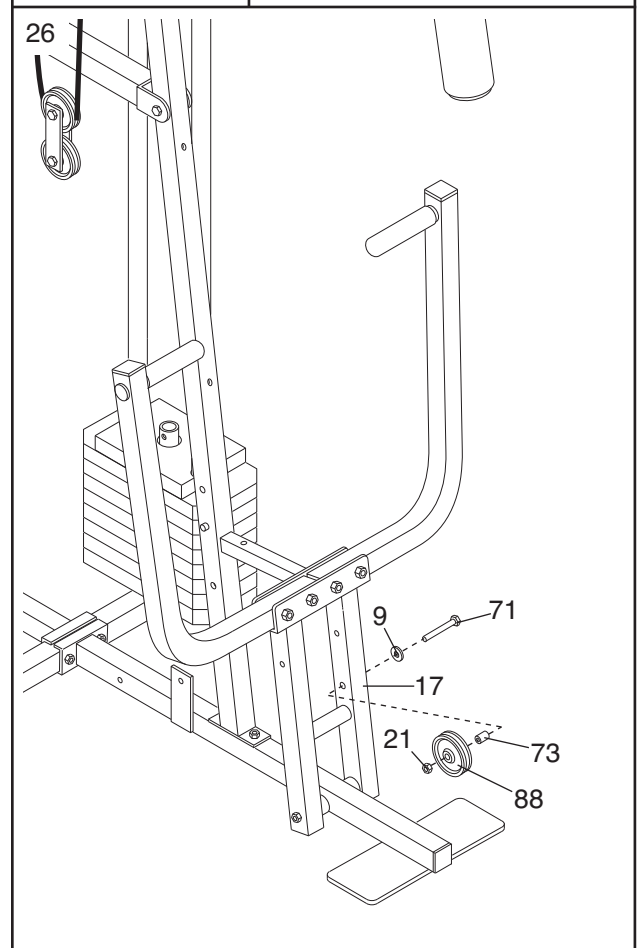

27. **Locate the Long Cable (86).** Route the Long Cable under the 3 1/2" Low Pulley (88). **Be sure that the end of the Cable with the ball is on the indicated side of the Press Frame (17) and that the Cable is between the Pulley and the crossbar on the Press Frame.** Tighten the 3/8" Nylon Locknut (21) and the 3/8" x 3 3/4" Bolt (not shown).

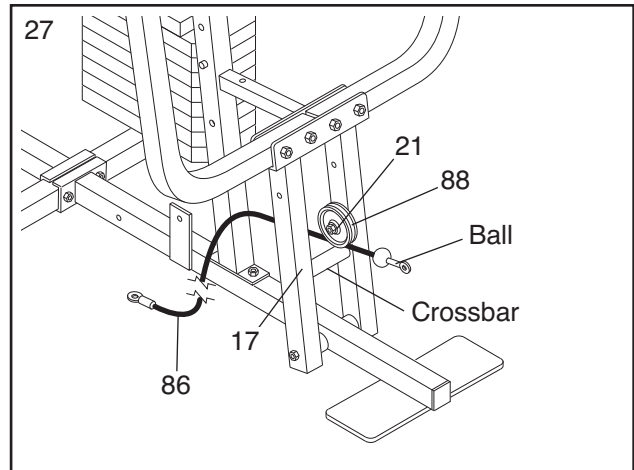

28. Wrap the Long Cable (86) around a 3 1/2" Pulley (15). Attach the Pulley and a Cable Trap (66) to the lower hole in the Front Upright (42) with a 3/8" x 3 3/4" Bolt (71), a 3/8" Flat Washer (9), and a 3/8" Nylon Locknut (21). **Be sure that the Cable Trap is turned to hold the Cable in place and that the Cable is routed around the Pulley as shown.**

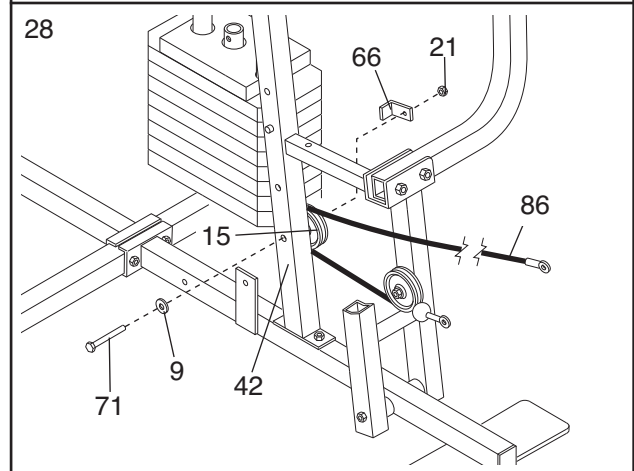

29. Wrap the Long Cable (86) around a 3 1/2" Pulley (15). Attach the Pulley and a Cable Trap (66) to the Press Frame (17) with a 3/8" x 3 1/2" Bolt (16), a 3/8" Flat Washer (9) and a 3/8" Nylon Locknut (21). **Be sure that the Cable Trap is turned to hold the Cable in place and that the Cable is routed around the Pulley as shown.**

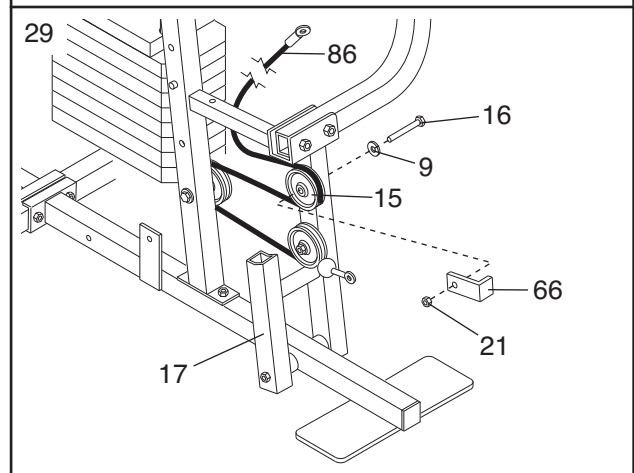

30. Wrap the Long Cable (86) around a "V"-Pulley (6). Attach the "V"-Pulley to the indicated hole in the Front Upright (42) with a 3/8" x 3 1/4" Bolt (85), a 3/8" Flat Washer (9), and a 3/8" Nylon Locknut (21). **Be sure that the Cable is in the groove of the "V"-Pulley and that the Cable is routed around the "V"-Pulley as shown.**

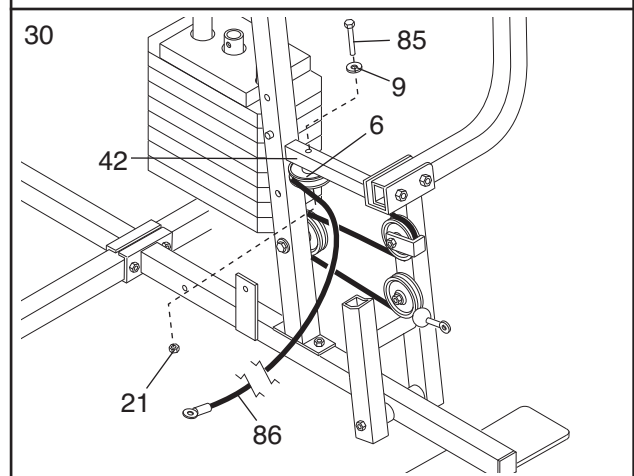

31. Wrap the Long Cable (86) around a 3 1/2" Pulley (15). Attach the Pulley and a Cable Trap (66) to the Press Frame (17) with a 3/8" x 3 1/2" Bolt (16), a 3/8" Flat Washer (9), and a 3/8" Nylon Locknut (21). **Be sure that the Cable Trap is turned to hold the Cable in place and that the Cable is routed around the Pulley as shown.**

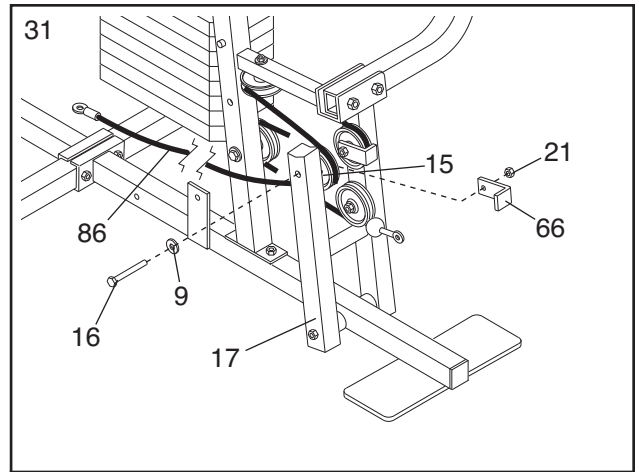

32. Wrap the Long Cable (86) around a 3 1/2" Pulley (15). Attach the Pulley and a Cable Trap (66) to the indicated hole in the Front Upright (42) with a 3/8" x 3 3/4" Bolt (71), a 3/8" Flat Washer (9), and a 3/8" Nylon Locknut (21). **Be sure that the Cable Trap is turned to hold the Cable in place and that the Cable is routed around the Pulley as shown.**

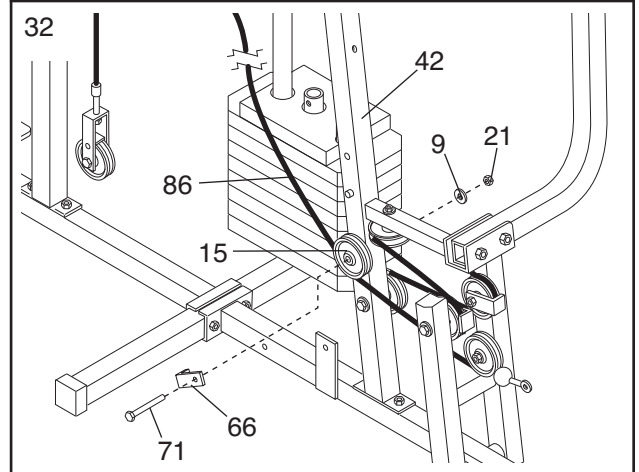

33. Route the Long Cable (86) over the lower 3 1/2" Pulley (15) attached to the "I"-Plates (81). The Cable must be routed from the direction shown.

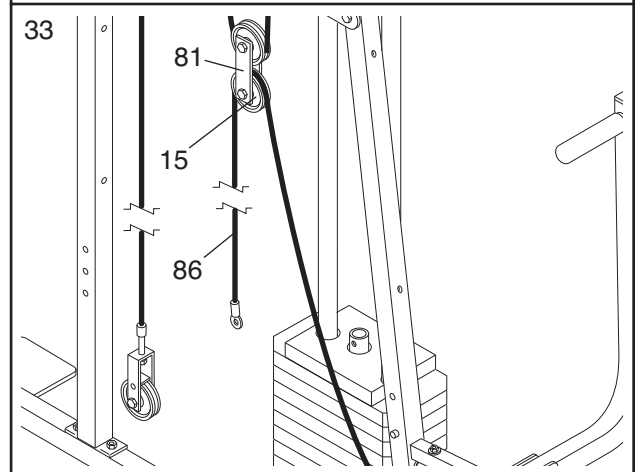

34. Wrap the Long Cable (86) around a 3 1/2" Pulley (15). Attach the Pulley and a Cable Trap (66) to the bracket on the Front Base (4) with a 3/8" x 2" Bolt (12) and a 3/8" Nylon Locknut (21). **Be sure that the Cable Trap is turned to hold the Cable in place and that the Cable is routed around the Pulley as shown.**

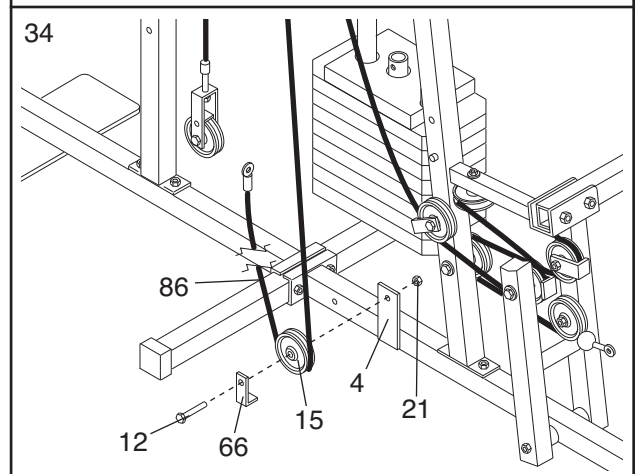

35. Route the Long Cable (86) around the indicated 3 1/2" Pulley (15) and through the Long "U"-Bracket (57). **The Cable must be between the Cable Trap (66) and the Pulley.** Tighten 3/8" x 2" Bolt (12) and the 3/8" Nylon Locknut (not shown). **Be sure that the Cable is in the groove of the Pulley and that the Cable and Pulley move smoothly.**

Attach the end of the Long Cable (86) to the Front Base (4) with a 5/16" x 2 3/4" Bolt (11), a 5/16" Flat Washer (8), and a 5/16" Nylon Locknut (3).

36. Attach the Small "U"-Bracket (67) to the Weight Tube (63) with the 5/16" x 1 3/4" Bolt (72) and a 5/16" Nylon Locknut (3).

37. Attach the Small Backrest (80) to the Rear Upright (56) with two 1/4" x 2 1/2" Screws (43) and two 1/4" Flat Washers (10).

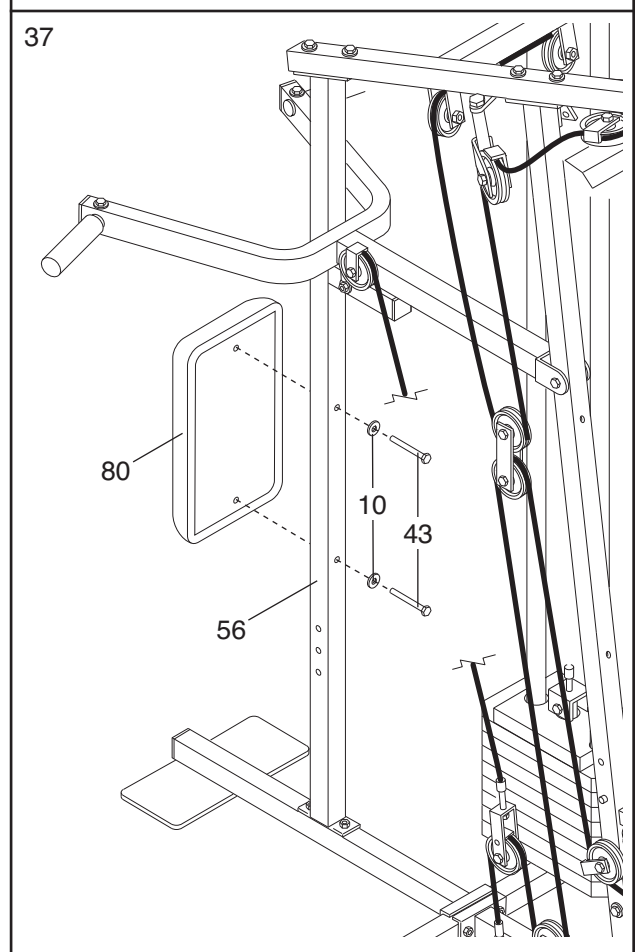
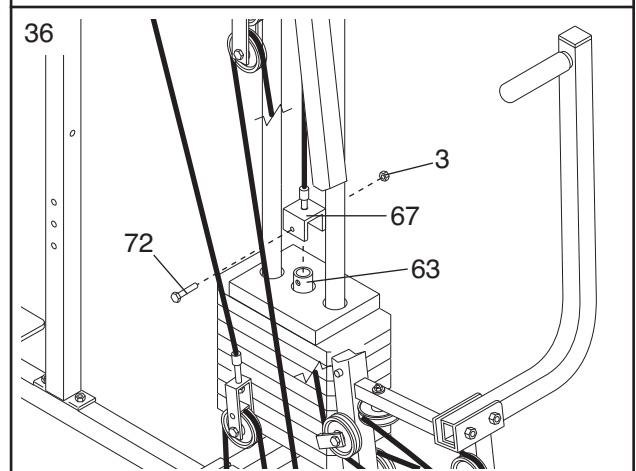
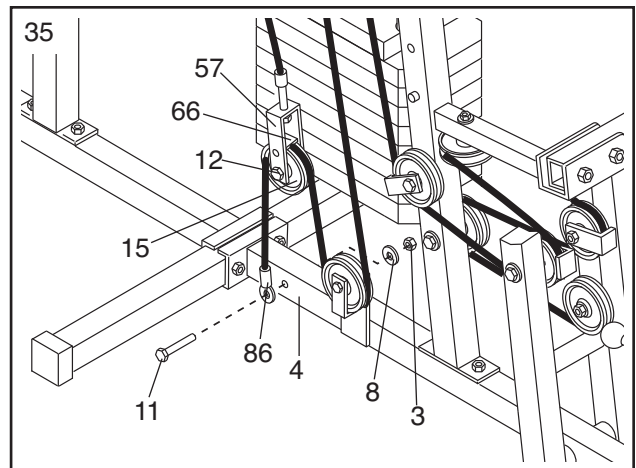

38. Press a 1 3/4" Square Inner Cap (44) into the Rear Seat Frame (77).

Insert the 1/4" x 2 1/2" Carriage Bolt (91) into the center hole in a Seat Plate (37). Attach the Seat Plate to a Seat (13) with two 1/4" x 1/2" Screws (18).

Insert the 1/4" x 2 1/2" Carriage Bolt (91) into the indicated hole in the Rear Seat Frame (77). Tighten a 1/4" Nylon Locknut (2) with a 1/4" Flat Washer (10) onto the Carriage Bolt.

Attach the other end of the Seat (13) to the Rear Seat Frame (77) with a 1/4" Flat Washer (10) and the 1/4" x 2 1/4" Screw (82).

39. Align the holes in the Rear Seat Frame (77) with one set of holes in the Rear Upright (56). Attach the Rear Seat Frame to the Rear Upright with a 5/16" x 2 3/4" Carriage Bolt (14) and a Seat Knob (40).

40. Attach the Large Backrest (41) to the Front Upright (42) with two 1/4" x 2 1/2" Screws (43) and two 1/4" Flat Washers (10). **The Backrest must be oriented as shown.**

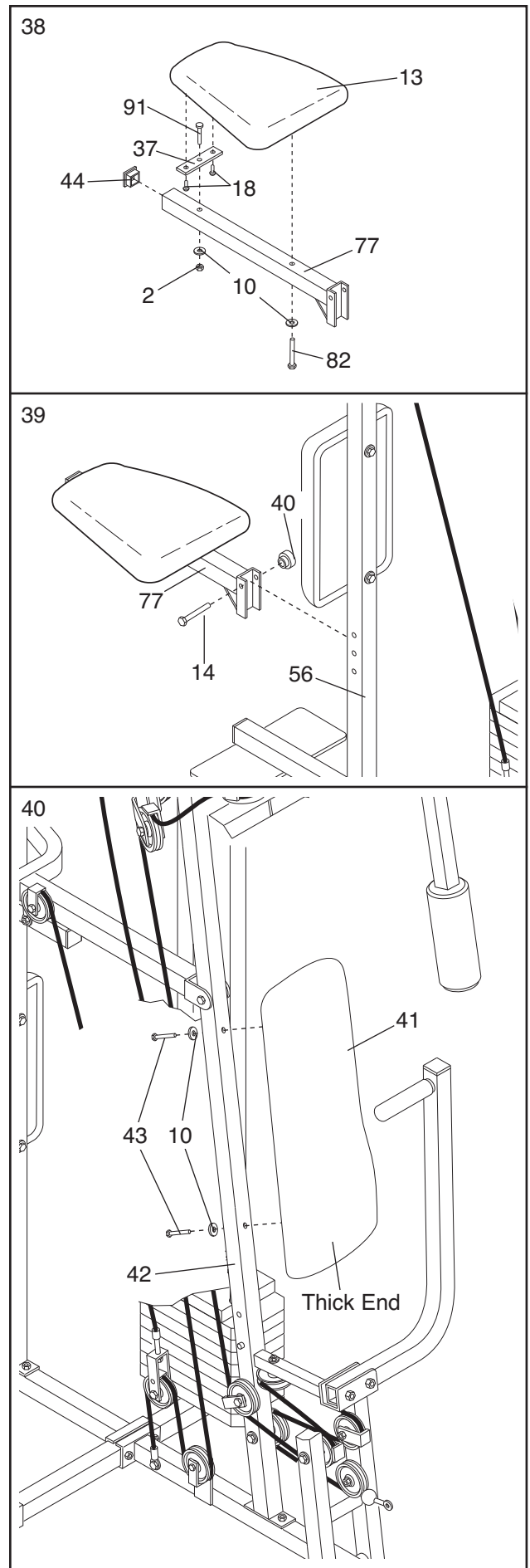

41. Press a 1 1/2" Square Inner Cap (32) into the Front Seat Frame (36).

Insert the 1/4" x 2 1/4" Carriage Bolt (38) into the center hole in a Seat Plate (37). Attach the Seat Plate to the Seat (13) with two 1/4" x 1/2" Screws (18).

Insert the 1/4" x 2 1/4" Carriage Bolt (38) into the indicated hole in the Front Seat Frame (36). Tighten a 1/4" Nylon Locknut (2) with a 1/4" Flat Washer (10) onto the Carriage Bolt.

Attach the other end of the Seat (13) to the Front Seat Frame (36) with a 1/4" Flat Washer (10) and the 1/4" x 2" Screw (24).

42. Press a 1 1/2" Square Inner Cap (32) into the Leg Lever (29).

Lubricate the 5/16" x 2 1/4" Bolt (33). Attach the Leg Lever (29) to the Seat Frame (36) with the 5/16" x 2 1/4" Bolt and a 3/8" Nylon Locknut (21). **Do not overtighten the Nylon Locknut. The Leg Lever must be able to pivot freely.**

Insert the 3/8" x 2" Eyebolt (35) into the Leg Lever (29) from the direction shown. Tighten a 3/8" Nylon Locknut (21) with a 3/8" Flat Washer (9) onto the Eyebolt.

43. Rest the Front Seat Frame (36) on the indicated pin in the Front Upright (42). Attach the Front Seat Frame to the Front Upright with a 5/16" x 2 3/4" Carriage Bolt (14) and the Seat Knob (40).

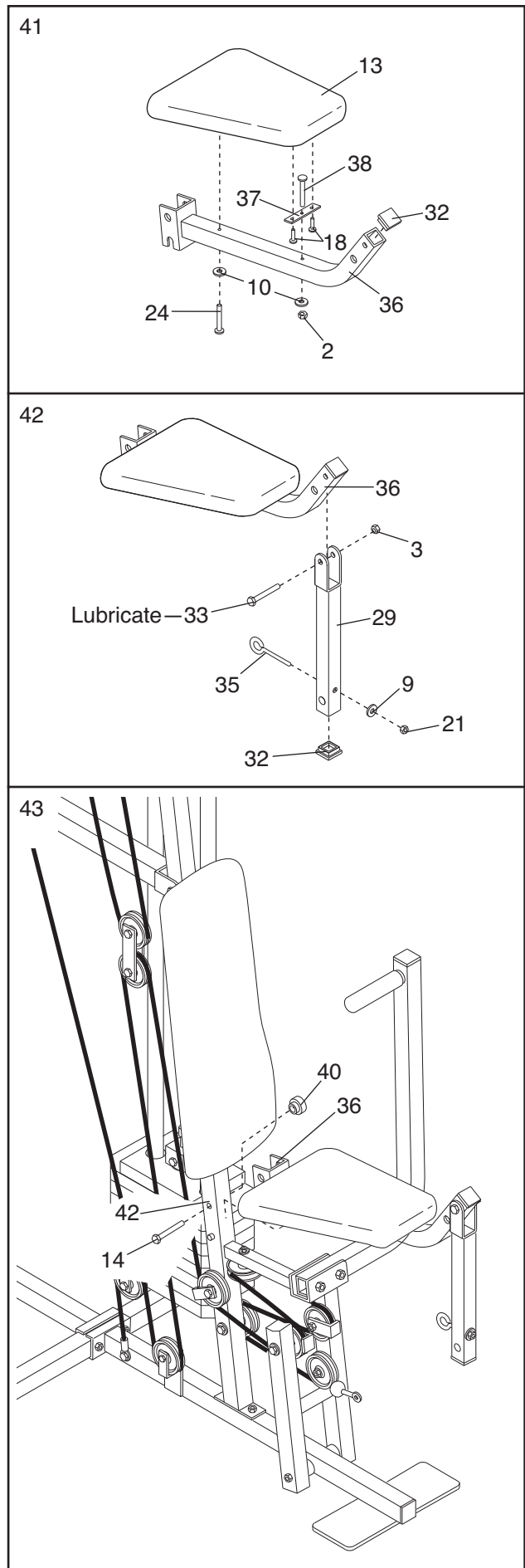

44. Press 3/4" Round Inner Caps (34) into the ends of both Pad Tubes (28).

Insert one Pad Tube (28) into the Front Seat Frame (36). Slide a Foam Pad (30) onto each end of the Pad Tube.

Insert the other Pad Tube (28) into the Leg Lever (29). Slide a Foam Pad (30) onto each end of the Pad Tube.

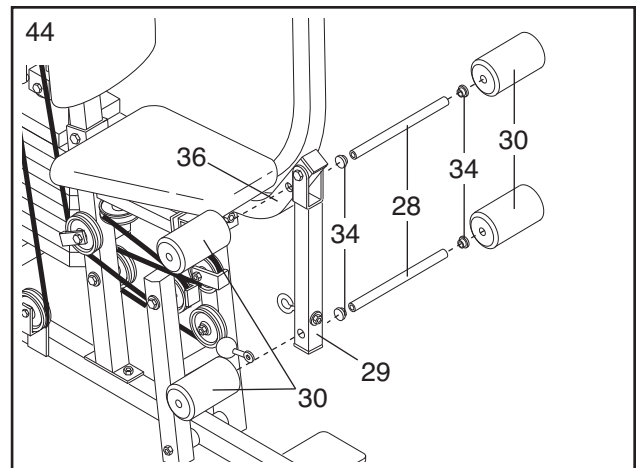

45. Remove the backing from the PRO 9625 decal and apply it to the home gym system as shown.

Make sure that all parts have been properly tightened. The use of the remaining parts will be explained in ADJUSTMENT, beginning on page 19 of this manual.

Before using the home gym system, pull each cable a few times to be sure that the cables move smoothly over the pulleys. If one of the cables does not move smoothly, find and correct the problem. **IMPORTANT: If the cables are not properly installed, they may be damaged when heavy weight is used. See the CABLE DIAGRAM attached to the PART ID CHART for proper cable routing. If there is any slack in the cables, you will need to remove it by tightening the cables. See TROUBLE-SHOOTING AND MAINTENANCE on page 22.**

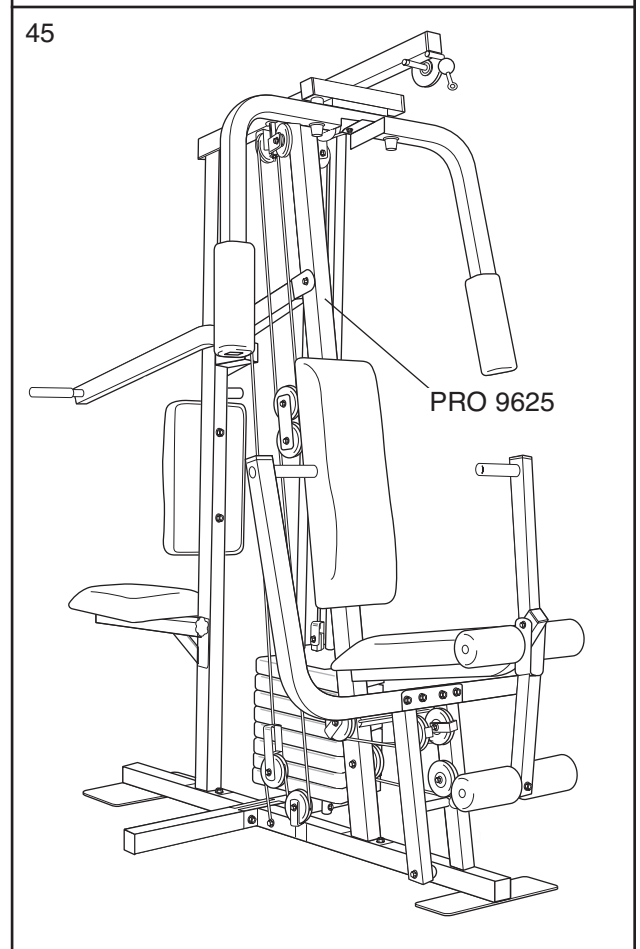

ADJUSTMENT

The instructions below describe how each part of the home gym system can be adjusted. Refer to the exercise poster accompanying this manual to see how the home gym system should be set up for each exercise.

IMPORTANT: When attaching the lat bar or nylon strap, make sure that the attachments are in the correct starting position for the exercise to be performed. If there is any slack in the cables or chain as an exercise is performed, the effectiveness of the exercise will be reduced.

CHANGING THE WEIGHT SETTING

To change the weight setting of the weight stack, insert a Weight Pin (26) under the desired Weight (25). Be sure to insert the Weight Pin until the bent end of the Weight Pin is touching the Weights, and turn the bent end downward. The weight setting of the weight stack can be changed from 6.5 pounds to 106.5 pounds, in increments of 12.5 pounds. **Note: Due to the cables and pulleys, the amount of resistance at each exercise station may vary from the weight setting. Use the WEIGHT RESISTANCE CHART on page 21 to find the approximate amount of resistance at each weight station.**

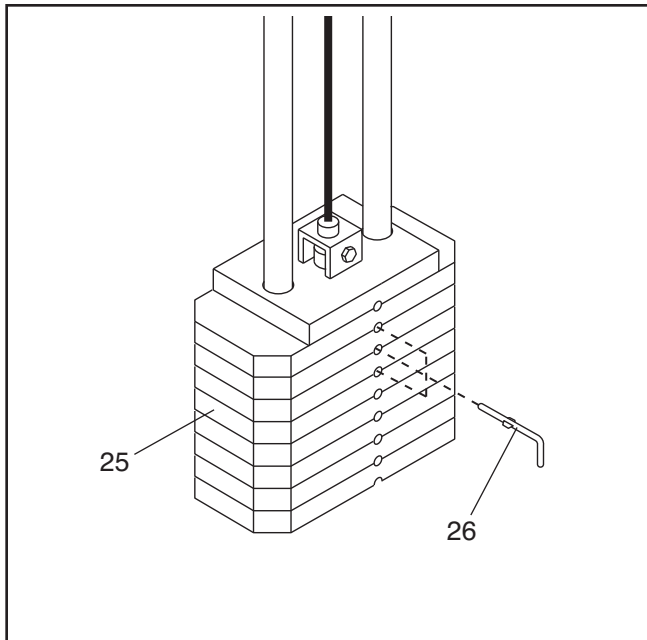

ATTACHING THE LAT BAR OR NYLON STRAP TO THE HIGH PULLEY STATION

Attach the Lat Bar (54) to the Medium Cable (23) with a Cable Clip (53). For some exercises, the Chain (52) should be attached between the Lat Bar and the Medium Cable with two Cable Clips. **Adjust the length of the Chain between the Lat Bar and the Medium Cable so the Lat Bar is in the correct starting position for the exercise to be performed.**

The Nylon Strap (39) can be attached in the same manner.

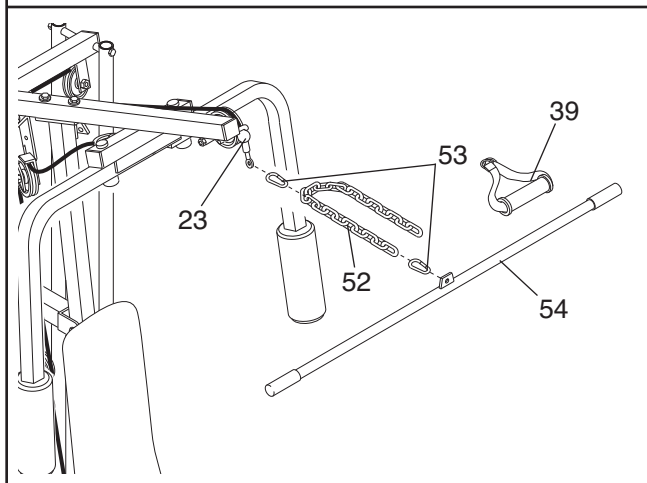

ATTACHING THE LAT BAR OR NYLON STRAP TO THE LOW PULLEY STATION

Attach the Lat Bar (54) to the Long Cable (86) with a Cable Clip (53). For some exercises, the Chain (52) should be attached between the Lat Bar and the Long Cable with two Cable Clips. **Adjust the length of the Chain between the Lat Bar and the Long Cable so the Lat Bar is in the correct starting position for the exercise to be performed.**

The Nylon Strap (39) can be attached in the same manner.

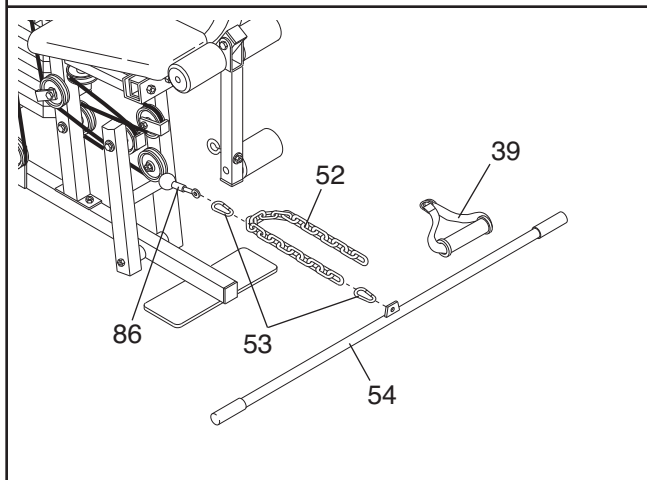

ATTACHING THE LEG LEVER TO THE LOW PULLEY STATION

To use the Leg Lever (29), the seat must be attached to the front upright (see ATTACHING AND REMOVING THE SEATS below).

Attach one end of the Chain (52) to the Long Cable (86) with a Cable Clip (53). Attach the other end of the Chain to the Eyebolt (35) with a Cable Clip. **Always remove the Chain (52) from the Eyebolt (35) before removing the seat.**

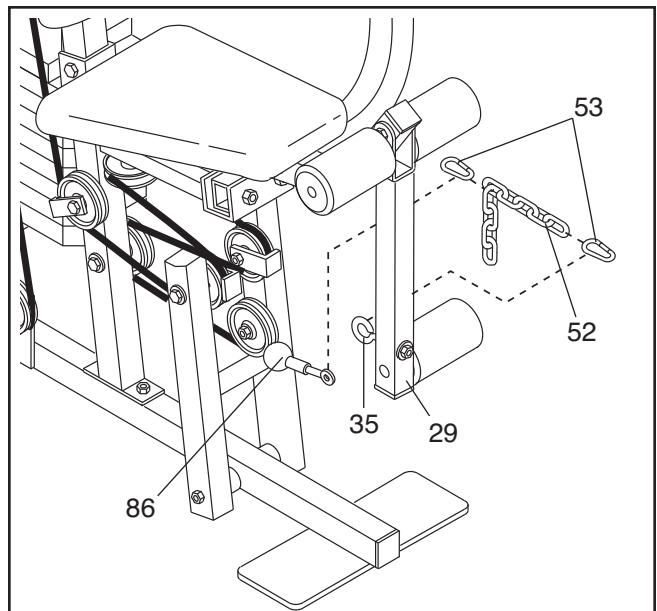

ATTACHING AND REMOVING THE SEATS

See drawing A. Set the bracket on the Front Seat Frame (36) onto the indicated pins on the Front Upright (42). Attach the Front Seat Frame to the Front Upright with the 5/16" x 2 3/4" Carriage Bolt (14) and the Seat Knob (40).

For some exercises, the Front Seat Frame (36) must be removed. First, be sure that the chain is not attached to the leg lever. Next, remove the Seat Knob (40) and the 5/16" x 2 3/4" Carriage Bolt (14) from the Front Seat Frame. Lift the Front Seat Frame off the Front Upright (42).

See drawing B. Align the holes in the Rear Seat Frame (77) with one set of holes in the Rear Upright (56). Attach the Rear Seat Frame to the Rear Upright with the 5/16" x 2 3/4" Carriage Bolt (14) and the Seat Knob (40).

For some exercises, the Rear Seat Frame (77) must be removed. Remove the Seat Knob (40) and the 5/16" x 2 3/4" Carriage Bolt (14) from the Rear Seat Frame. Lift the Seat Frame off the Rear Upright (56).

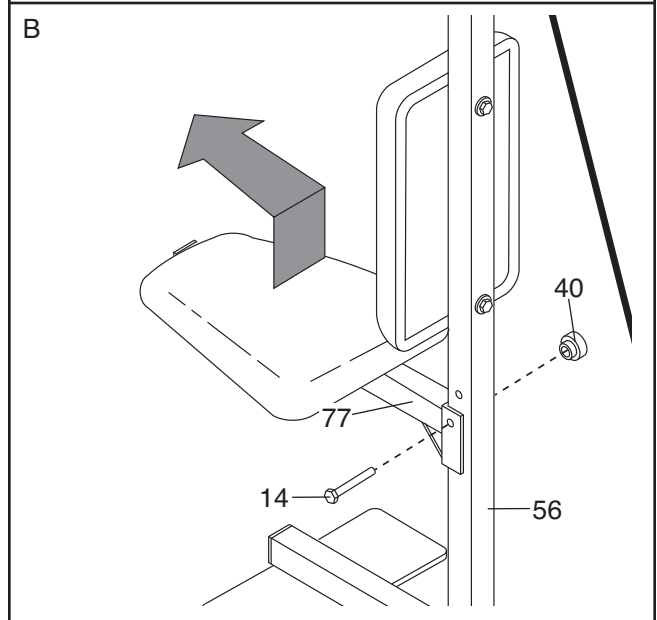
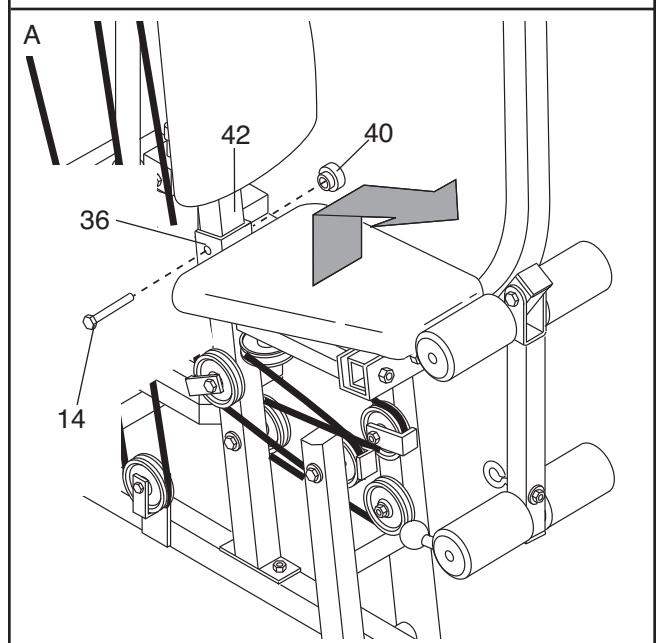

WEIGHT RESISTANCE CHART

This chart shows the approximate weight resistance at each station. "Top" refers to the 6.5 lb. top weight. The other numbers refer to the 12.5 lb. weight plates. Weight resistance shown for the butterfly arm station is for each butterfly arm.

WEIGHT PLATES	PRESS ARM (lbs.)	BUTTERFLY ARM (lbs.)	LEG LEVER (lbs.)	HIGH PULLEY (lbs.)	LOW PULLEY (lbs.)	SQUAT ARM (lbs.)
Top	24	14	21	15	19	31
1	45	21	41	30	34	58
2	69	42	60	43	52	77
3	98	51	76	58	68	102
4	117	65	87	74	82	143
5	142	86	101	92	98	169
6	162	94	116	106	117	196
7	191	118	140	121	128	204
8	210	126	169	134	147	215

The actual resistance at each weight station may vary due to differences in individual weight plates, as well as friction between the cables, pulleys, and weight guides.

TROUBLE-SHOOTING AND MAINTENANCE

Inspect and tighten all parts each time you use the home gym system. Replace any worn parts immediately. The home gym system can be cleaned using a damp cloth and mild non-abrasive detergent. Do not use solvents.

TIGHTENING THE CABLES

Woven cable, the type of cable used on the home gym system, can stretch slightly when it is first used. If there is slack in the cables before resistance is felt, the cables should be tightened. Insert the Weight Pin (26) under one of the indicated Weights (25). Slack can be removed from the cables by tightening the 1/4" Nylon Locknuts (2) at the end of the Medium Cable (23) (see drawing 1) and at the end of the Short Cable (58) (see drawing 2). To do this you may need to remove the Small "U"-Bracket (67) from the Weight Tube (not shown) or remove the 3 1/2" Pulley (15) from the Long "U"-Bracket (57). Make sure that the cables are not too tight or the Top Weight (76) will be lifted off the weight stack.

Additional slack can be removed by moving the 3 1/2" Pulley (15) to the other hole in the Long "U"-Bracket (57). Remove the 3/8" Nylon Locknut (21) and the 3/8" x 2" Bolt (12) from the Cable Trap (66), Pulley, and "U"-Bracket. Re-attach the Pulley and Cable Trap. Be sure that the Cable trap is in the proper position and that the Cable and Pulley move smoothly.

Note: If a cable tends to slip off the pulleys often, the cable may have become twisted. Remove the cable and re-install it.

If the cables need to be replaced, see ORDERING REPLACEMENT PARTS on the back cover of this manual.

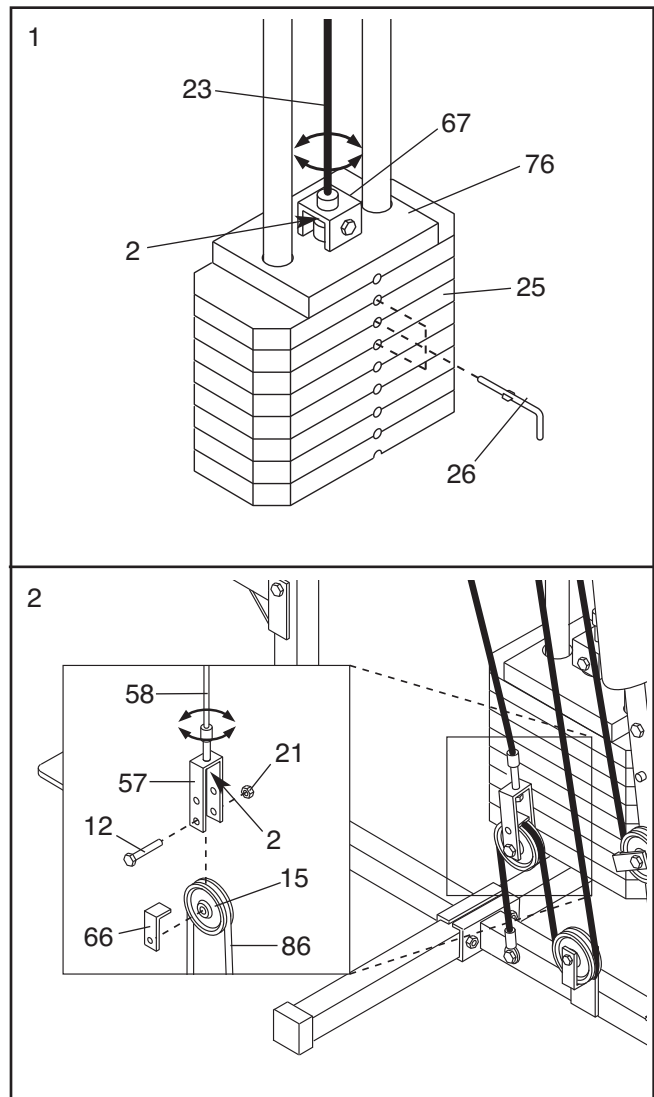

LIMITED WARRANTY

ICON OF/DU CANADA INC., (ICON), warrants this product to be free from defects in workmanship and material, under normal use and service conditions, for a period of ninety (90) days from the date of purchase. This warranty extends only to the original purchaser. ICON's obligation under this warranty is limited to replacing or repairing, at ICON's option, the product at one of its authorized service centers. All products for which warranty claim is made must be received by ICON at one of its authorized service centers with all freight and other transportation charges prepaid, accompanied by sufficient proof of purchase. All returns must be pre-authorized by ICON. This warranty does not extend to any product or damage to a product caused by or attributable to freight damage, abuse, misuse, improper or abnormal usage or repairs not provided by an ICON authorized service center, to products used for commercial or rental purposes, or to products used as store display models. No other warranty beyond that specifically set forth above is authorized by ICON.

ICON is not responsible or liable for indirect, special or consequential damages arising out of or in connection with the use or performance of the product or damages with respect to any economic loss, loss of property, loss of revenues or profits, loss of enjoyment or use, costs of removal, installation or other consequential damages of whatsoever nature. Some provinces do not allow the exclusion or limitation of incidental or consequential damages. Accordingly, the above limitation may not apply to you. The warranty extended hereunder is in lieu of any and all other warranties and any implied warranties of merchantability or fitness for a particular purpose is limited in its scope and duration to the terms set forth herein. Some provinces do not allow limitations on how long an implied warranty lasts. Accordingly, the above limitation may not apply to you.

The warranty extended hereunder is in lieu of any and all other warranties and any implied warranties of merchantability or fitness for a particular purpose is limited in its scope and duration to the terms set forth herein.

This warranty gives you specific legal rights. You may also have other rights which vary from province to province or so specified by the retailer of your equipment.

ICON OF/DU CANADA, 900 de l'Industrie, St-Jérôme, QC J7Y 4B8

**PLACE
STAMP
HERE**

ICON of Canada Inc.
900 de l'Industrie
St-Jérôme, Québec
Canada, J7Y 4B8

CABLE DIAGRAM

The cable diagram below shows the proper routing of the Short Cable (58), the Medium Cable (23), and the Long Cable (86). Use the diagram to be sure that the three cables and the cable traps have been assembled correctly. If the cables have not been correctly routed, the home gym system will not function properly and damage may occur. The numbers show the correct route for each cable. The starting and ending points of each cable are labeled. **Be sure that the cable traps do not touch or bind the cables.**

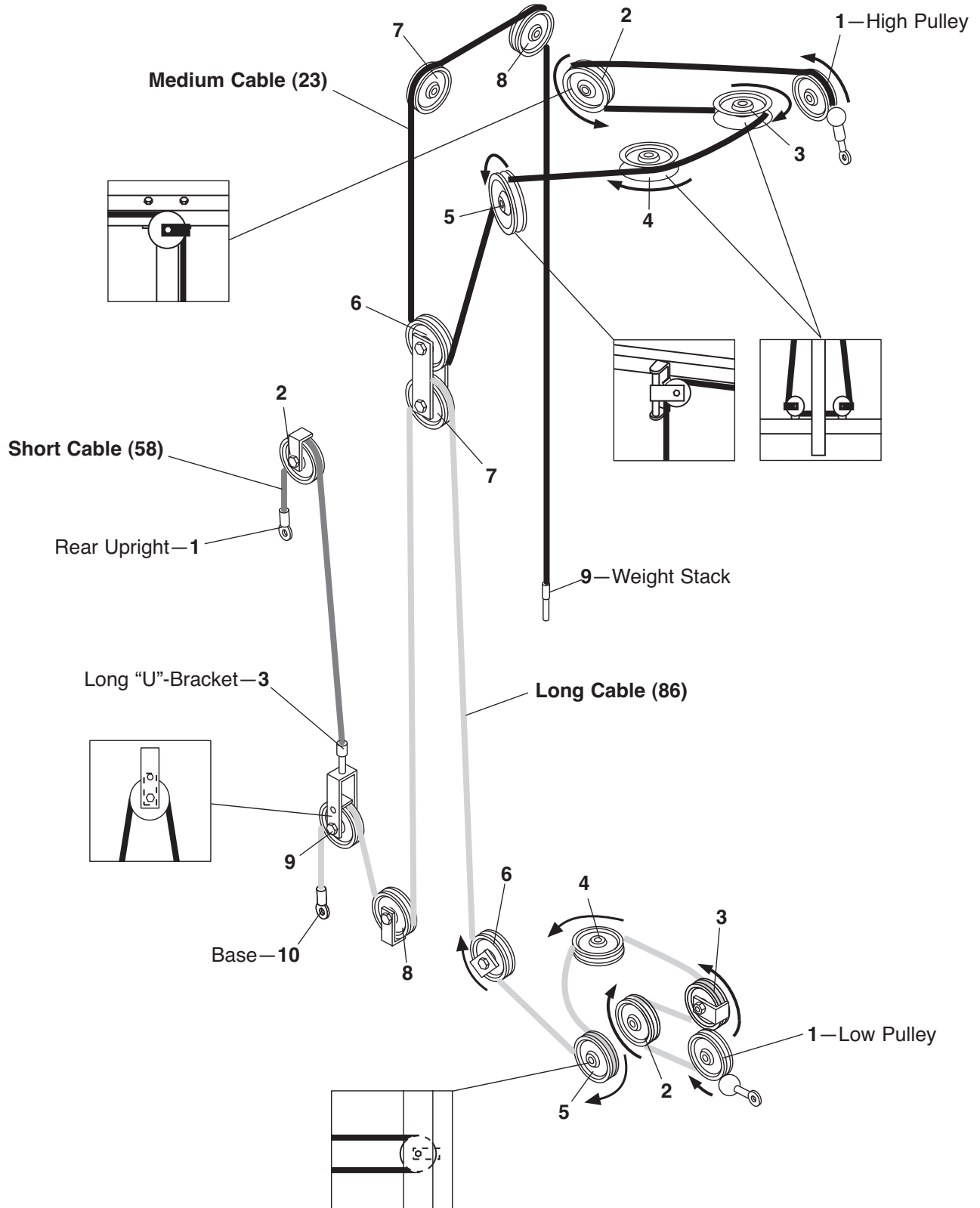

REMOVE THIS PART IDENTIFICATION CHART FROM THE MANUAL

This chart is provided to help you identify the small parts used in assembly. **Important: Some parts may have been pre-assembled for shipping purposes. If you cannot find a part in the parts bags, check to see if it has been pre-assembled.** The number in parenthesis below each part refers to the key number of the part. The second number refers to the quantity needed for assembly.

Please Note: The assembly is divided into four stages: 1) frame assembly, 2) press, squat, and butterfly arm assembly, 3) cable and pulley assembly, and 4) seat and backrest assembly. The hardware for each stage is packaged separately. Wait until you begin each assembly stage to open that parts bag.

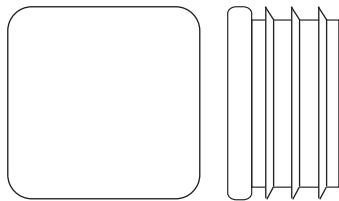

1" Square Inner Cap (65)—1

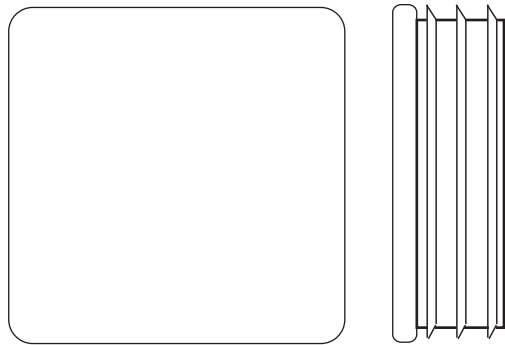

1 3/4" Square Inner Cap (44)—7

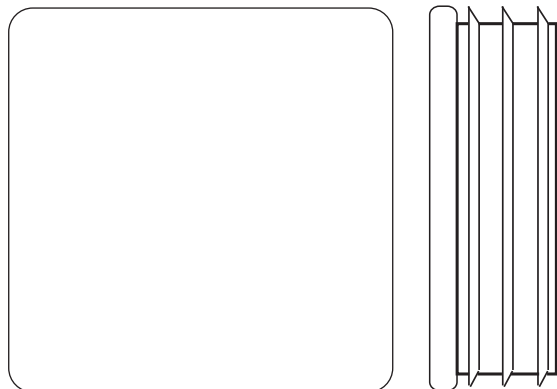

2" Square Inner Cap (27)—6



2" Square Cover Cap (78)—2

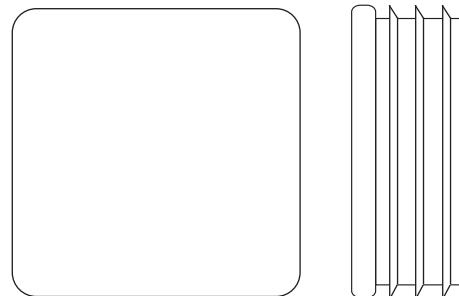

1 1/2" Square Inner Cap (32)—2



1" x 2" Endcap (83)—2

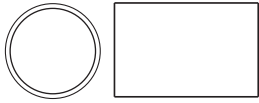

1/2" x 3/4" Spacer (61)-2

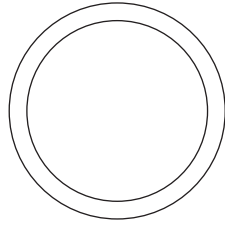

1 1/8" x 2 1/2" Plastic Bushing (74)-2

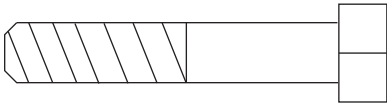

5/16" x 1 3/4" Bolt (72)-1

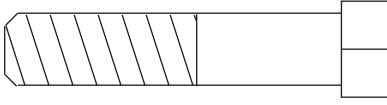

3/8" x 1 3/4" Bolt (87)-4

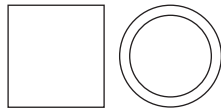

1/2" x 17/32" Spacer (94)-2

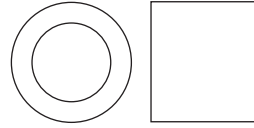

5/8" x 9/16" Spacer (73)-1



3/8" x 2" Bolt (12)-3

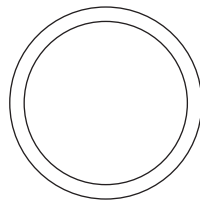

1" x 7/8" Plastic Bushing (75)-2

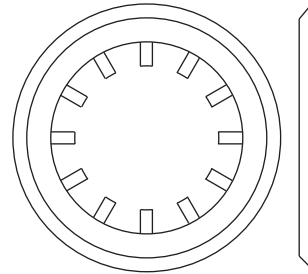

1" Retainer (69)-4



3/8" x 2 1/2" Bolt (7)-3

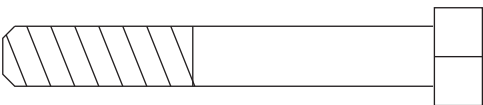

5/16" x 2 1/4" Bolt (33)-1



5/16" x 2 1/2" Bolt (22)-6

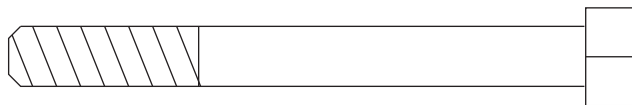

5/16" x 3" Bolt (93)-1

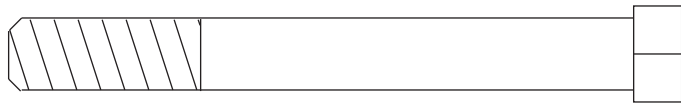

3/8" x 3 1/4" Bolt (85)-2

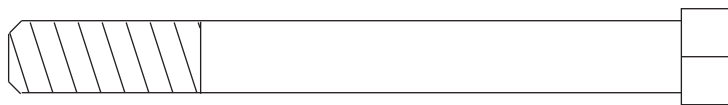

3/8" x 3 1/2" Bolt (16)-2

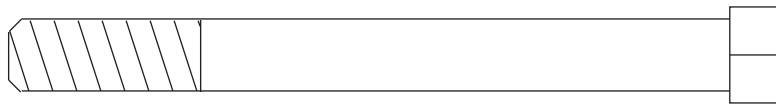

3/8" x 3 3/4" Bolt (71)-5

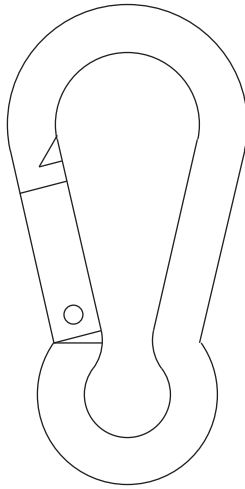

Cable Clip (53)-2

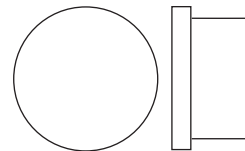

3/4" Round Inner Cap (34)-4

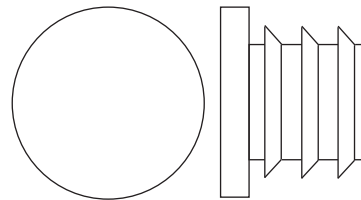

1" Round Inner Cap (49)-6

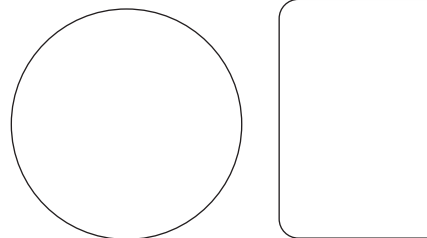

1" Round Cover Cap (70)-4

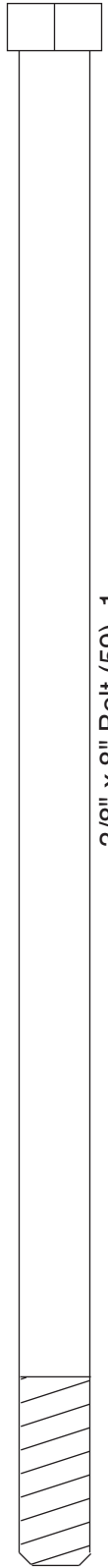

3/8" x 8" Bolt (59)-1

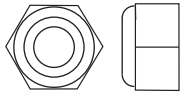

1/4" Nylon Locknut (2)-4



1/4" x 2" Screw (24)-1

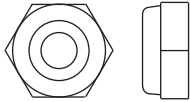

5/16" Nylon Jam Nut (84)-2

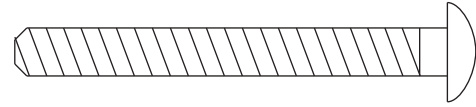

1/4" x 2 1/4" Carriage Bolt (38)-1

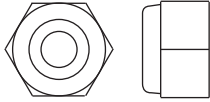

5/16" Nylon Locknut (3)-21

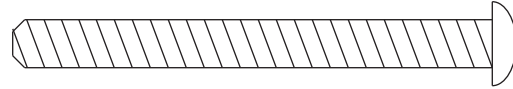

1/4" x 2 1/2" Screw (43)-4

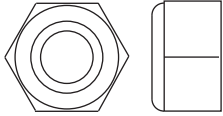

3/8" Nylon Locknut (21)-21

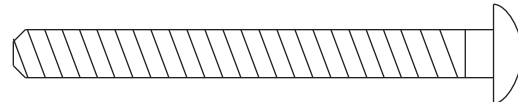

1/4" x 2 1/2" Carriage Bolt (91)-1

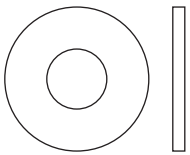

1/4" Flat Washer (10)-10

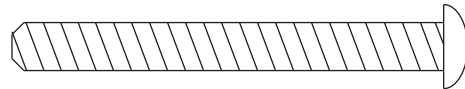

1/4" x 2 1/4" Screw (82)-1

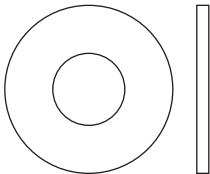

5/16" Flat Washer (8)-10

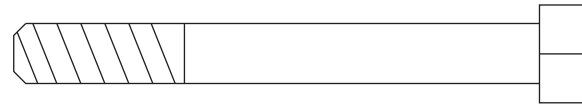

5/16" x 2 3/4" Bolt (11)-7

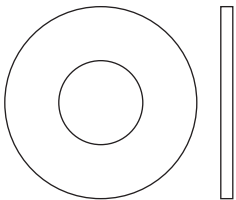

3/8" Flat Washer (9)-8

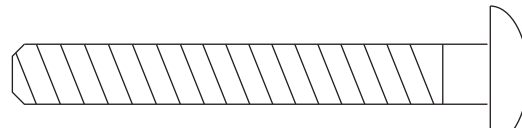

5/16" x 2 1/2" Carriage Bolt (1)-4

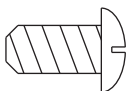

1/4" x 1/2" Screw (18)-4



5/16" x 2 3/4" Carriage Bolt (14)-2

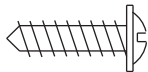

#8 x 1/2" Self Tapping Screw (89)-1

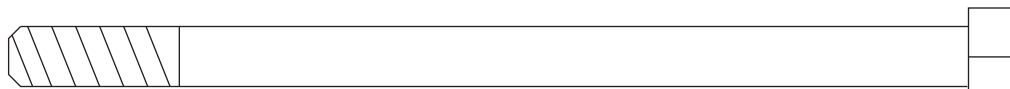

5/16" x 5" Bolt (68)-1

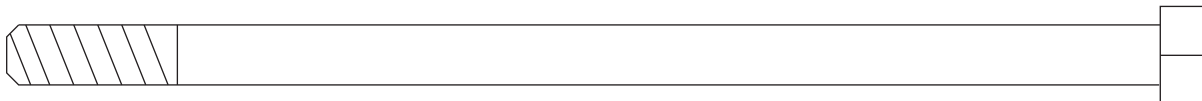

5/16" x 6" Bolt (60)-1

PART LIST—Model No. WESY96252

R0803A

Key No.	Qty.	Description	Key No.	Qty.	Description
1	4	5/16" x 2 1/2" Carriage Bolt	49	6	1" Round Inner Cap
2	4	1/4" Nylon Locknut	50	3	Long Cable Trap
3	21	5/16" Nylon Locknut	51	1	Rear Base
4	1	Front Base	52	1	Chain
5	1	Stabilizer	53	2	Cable Clip
6	4	"V"-Pulley	54	1	Lat Bar
7	3	3/8" x 2 1/2" Bolt	55	1	Top Frame
8	10	5/16" Flat Washer	56	1	Rear Upright
9	8	3/8" Flat Washer	57	1	Long "U"-Bracket
10	10	1/4" Flat Washer	58	1	Short Cable
11	7	5/16" x 2 3/4" Bolt	59	1	3/8" x 8" Bolt
12	5	3/8" x 2" Bolt	60	1	5/16" x 6" Bolt
13	2	Seat	61	2	1/2" x 3/4" Spacer
14	2	5/16" x 2 3/4" Carriage Bolt	62	2	Weight Guide
15	13	3 1/2" Pulley	63	1	Weight Tube
16	2	3/8" x 3 1/2" Bolt	64	1	Weight Tube Bumper
17	1	Press Frame	65	1	1" Square Inner Cap
18	4	1/4" x 1/2" Screw	66	8	Cable Trap
19	2	Weight Bumper	67	1	Small "U"-Bracket
20	1	Pulley Bracket	68	1	5/16" x 5" Bolt
21	21	3/8" Nylon Locknut	69	4	1" Retainer
22	6	5/16" x 2 1/2" Bolt	70	4	1" Round Cover Cap
23	1	Medium Cable	71	5	3/8" x 3 3/4" Bolt
24	1	1/4" x 2" Screw	72	1	5/16" x 1 3/4" Bolt
25	8	Weight	73	1	5/8" x 9/16" Spacer
26	1	Weight Pin	74	2	1 1/8" x 2 1/2" Plastic Bushing
27	6	2" Square Inner Cap	75	2	1" x 7/8" Plastic Bushing
28	2	Pad Tube	76	1	Top Weight
29	1	Leg Lever	77	1	Rear Seat Frame
30	4	Foam Pad	78	2	2" Square Cover Cap
31	6	Hand Grip	79	1	Squat Arm
32	2	1 1/2" Square Inner Cap	80	1	Small Backrest
33	1	5/16" x 2 1/4" Bolt	81	2	"I" Plate
34	4	3/4" Round Inner Cap	82	1	1/4" x 2 1/4" Screw
35	1	3/8" x 2" Eyebolt	83	2	1" x 2" Inner Cap
36	1	Front Seat Frame	84	2	5/16" Nylon Jam Nut
37	2	Seat Plate	85	2	3/8" x 3 1/4" Bolt
38	1	1/4" x 2 1/4" Carriage Bolt	86	1	Long Cable
39	1	Nylon Strap	87	2	3/8" x 1 3/4" Bolt
40	2	Seat Knob	88	1	3 1/2" Low Pulley
41	1	Large Backrest	89	1	#8 x 1/2" Tap Screw
42	1	Front Upright	90	1	Rubber Bumper
43	4	1/4" x 2 1/2" Screw	91	1	1/4" x 2 1/2" Carriage Bolt
44	7	1 3/4" Square Inner Cap	92	2	Handle
45	2	10" Pad	93	1	5/16" x 3" Bolt
46	2	Press Arm	94	2	1/2" x 17/32" Spacer
47	1	Left Arm	#	1	User's Manual
48	1	Right Arm	#	1	Exercise Poster

Note: "#" indicates a non-illustrated part. Specifications are subject to change without notice.

EXPLODED DRAWING—Model No. WESY96252

R0803A

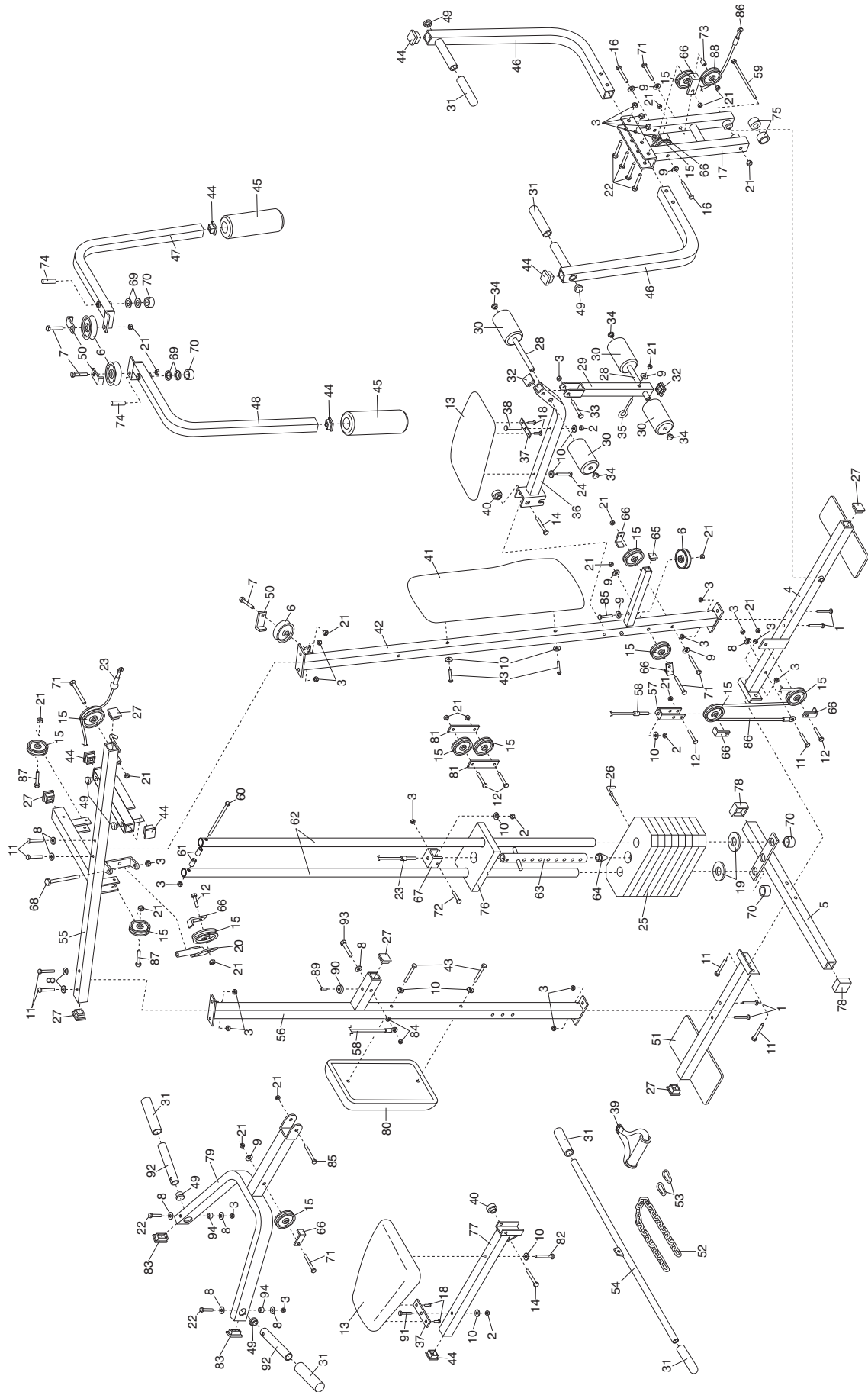

ORDERING REPLACEMENT PARTS

To order replacement parts, simply call our Customer Service Department toll-free at 1-800-936-4266, Monday through Friday, 8 a.m. until 6:30 p.m. EST (excluding holidays). To help us assist you, please be prepared to give the following information:

1. The MODEL NUMBER of the product (WESY96252).
2. The NAME of the product (WEIDER® 9625 Home Gym System).
3. The SERIAL NUMBER of the product (see the front cover of this manual).
4. The KEY NUMBER and DESCRIPTION of the part(s) (see the PART LIST and EXPLODED DRAWING at the center of this manual).

Part No. 185136 R0803A

Printed in Canada © 2003 ICON Health & Fitness, Inc.

		PRODUCT WARRANTY REGISTRATION	
IMPORTANT: MAIL WITHIN 14 DAYS OF PURCHASE			
NAME: _____		PHONE: _____	
ADDRESS: _____			
COUNTY: _____		POSTCODE: _____	
MODEL NO. _____	SERIAL NO. _____	PURCHASE DATE: _____	
RETAILER NAME: _____		RETAILER ADDRESS: _____	
1) Primary user(s) of product: <input type="checkbox"/> Male <input type="checkbox"/> Female <input type="checkbox"/> Family		8) Did you consider purchasing fitness equipment from another manufacturer? <input type="checkbox"/> No <input type="checkbox"/> Yes What other Manufacturer? _____	
2) Age of primary user: <input type="checkbox"/> 0-24 <input type="checkbox"/> 35-44 <input type="checkbox"/> 55-64 <input type="checkbox"/> 25-34 <input type="checkbox"/> 45-54 <input type="checkbox"/> 65 and over		9) Based on your impression of what you have purchased, would you buy another ICON product? <input type="checkbox"/> Yes <input type="checkbox"/> No <input type="checkbox"/> No Opinion If not, what other brand name equipment would you purchase? _____	
3) Annual household income: <input type="checkbox"/> 0-9,999 <input type="checkbox"/> 15,000-19,999 <input type="checkbox"/> 10,000-14,999 <input type="checkbox"/> 20,000+		10) What other type of exercise equipment do you own? <input type="checkbox"/> Bicycle <input type="checkbox"/> Exercise Cycle <input type="checkbox"/> Treadmill <input type="checkbox"/> Home Gym <input type="checkbox"/> Weight Bench <input type="checkbox"/> Stepper <input type="checkbox"/> Cardio Glide <input type="checkbox"/> Other	
4) How many times a week do you exercise? <input type="checkbox"/> Less than 3 times <input type="checkbox"/> 3 times or more		11) Which type of magazines do you read regularly? <input type="checkbox"/> Sports <input type="checkbox"/> Fitness <input type="checkbox"/> Motoring <input type="checkbox"/> Business <input type="checkbox"/> Computer <input type="checkbox"/> General	
5) Have you ever purchased an ICON product before? <input type="checkbox"/> Yes <input type="checkbox"/> No		12) Do you wish to be sent further bulletins about ICON products? <input type="checkbox"/> Yes <input type="checkbox"/> No	
6) Where did you first see or hear about ICON products? <input type="checkbox"/> Magazine <input type="checkbox"/> Friend/relative <input type="checkbox"/> Newspaper Ad <input type="checkbox"/> Store <input type="checkbox"/> Other		7) What was the primary reason for purchasing this ICON product? <input type="checkbox"/> Store Employee <input type="checkbox"/> Television Ads <input type="checkbox"/> Colour <input type="checkbox"/> Electronic Features <input type="checkbox"/> Magazine Ads <input type="checkbox"/> Price <input type="checkbox"/> Product Design <input type="checkbox"/> Product Innovation <input type="checkbox"/> Other Features	
THANK YOU FOR YOUR TIME			
© 2003 ICON of Canada, Inc. Printed in Canada			