



blood pressure monitor

upper arm



instruction manual



Contents

Introduction 5

Symbols and key words used in these instructions 6

About this device 7

Safety instructions 8

Frequently Asked Questions 12

Before taking your blood pressure measurement..... 16

How does the blood pressure monitor work..... 18

What’s included 19

Overview of the monitor 20

Preparing the device 23

Basic Settings..... 25

Switch device on and off 31

Measuring your blood pressure and pulse..... 32

Retrieving saved measurements..... 42





Error messages and troubleshooting	45
Cleaning, storing and servicing your blood pressure monitor.....	47
Disposal.....	48
Technical specifications	49
FCC Statement	50
Limited Warranty.....	52





Introduction

Thank you for purchasing the Welby® Upper Arm Blood Pressure Monitor. This fully automatic device measures blood pressure and pulse rate and detects an irregular heart beat (arrhythmia) fast and easily and then displays the results on the LCD screen. It works using the oscillometric method of blood pressure measurement. This means the monitor detects your blood's movement through your brachial artery and converts the movements into a digital reading. An oscillometric monitor does not need a stethoscope so the monitor is simple to use by oneself.

Please read this manual thoroughly before use and save it for future reference.



NOTE

We highly recommend that you consult with your physician or licensed healthcare professional if you have any questions about your blood pressure either before or as a result of using this monitor.

Please also save your original receipt as proof of purchase. It may be required to validate your warranty in case you need service for this device.



Symbols and key words used in these instructions



CAUTION!

Please note the following guidelines to avoid possibly injury and/or property damage.



NOTICE!

Additional information on using the device.

- Bulleted item/information on operating steps and results
- ▶ Tasks to be performed





About this device

This device is intended for use in dry, indoor areas only. The device is only intended for private use and not for industrial or commercial use. Use under extreme environmental conditions may result in damage to the device.

If the results obtained give you cause to be concerned about your health, please discuss them with your physician or licensed healthcare professional. Do not take any treatment or medication as a result of the values unless you have discussed this with your physician. Do not change any treatments or dosage of medication.

The manufacturer is not liable for damages that are caused by improper use or operation.

Improper use

Do not use this blood pressure monitor for medical diagnosis. It cannot replace medical intervention.





Safety instructions

General

- This device is intended for personal home use only.
- Do not use this device for self-diagnosis or self-treatment. Contact your physician or other licensed health care provider if you are concerned about your blood pressure.
- Keep plastic packaging out of the reach of children. There is a risk of suffocation.
- Keep the device and its accessories out of reach of children.
- Do not inflate (with the button) until the device is attached correctly to the arm.
- Do not drop the device and do not place objects on top of it.
- Avoid contact with water or moisture.
- Do not use or store the device in extreme temperature conditions.
- Do not bend or fold the fixed part of the cuff.





Safe handling of batteries

Batteries may contain combustible materials. If not handled correctly, batteries can leak, become very hot, ignite or even explode, which could damage your device and/or cause injuries. It is very important that you follow the instructions below:

- Keep batteries away from children. If batteries are mistakenly swallowed, call poison control or 911 immediately.
- Before inserting the batteries, check that the contacts in the device and on the batteries are clean and, if necessary, clean them.
- Never charge batteries (unless it is expressly specified). Risk of explosion!
- Never short-circuit the batteries.
- Do not dismantle or deform the batteries. You could injure your hands or fingers or battery fluid could come into contact with your eyes or skin. If this happens, rinse the affected areas immediately with a large amount of clean water and contact your physician immediately.
- Never expose the batteries to excessive heat (such as direct sunlight, fire or similar).
- Always observe the correct polarity. Make sure that the plus (+) and minus (-) poles are correctly inserted to avoid short circuits.
- Remove discharged batteries from the device immediately.



- Remove the batteries from the device if you do not intend to use it for an extended period.
- Replace all of the old batteries in a device with new batteries of the same type.

Service & Repairs

Please contact the Customer Care line if you have questions about the device or experience technical problems.

Never try to open or repair the device yourself. There are no user serviceable parts inside and it will void your warranty.





Danger of disruption from electrical fields

Measurements may be inaccurate in the proximity of strong electrical fields. Do not take any measurements near:

- High voltage power lines
- Microwave appliances
- TV sets
- Wireless telephones





Frequently Asked Questions

What is blood pressure?

Blood pressure is the force exerted by blood against the walls of the arteries as blood is pumped through the circulatory system and is measured in millimeters of mercury (mmHg). The higher the pressure, the harder the heart has to work to supply blood to the vital organs in the body.

What are systolic and diastolic values?

With every heartbeat, blood pressure fluctuates between a maximum value (systolic), when the heart contracts and pumps blood into the circulatory system, and a minimum value when the heart expands and fills up with blood again (diastolic).

What is High Blood Pressure and how is it controlled?

High Blood Pressure, also called by its medical term Hypertension, is an abnormally high arterial blood pressure. If left unattended, it can cause many health problems including stroke and heart attack.

Blood pressure can be higher than usual if parts of the circulatory system are restricted,

12





diseased or abnormal in other ways High Blood Pressure can be controlled by altering one's lifestyle, avoiding stress, and with medication under a physician's supervision. To prevent hypertension or to keep it under control:

- Do not smoke
- Exercise regularly
- Reduce salt and fat intake
- Have regular physical checkups
- Maintain proper weight

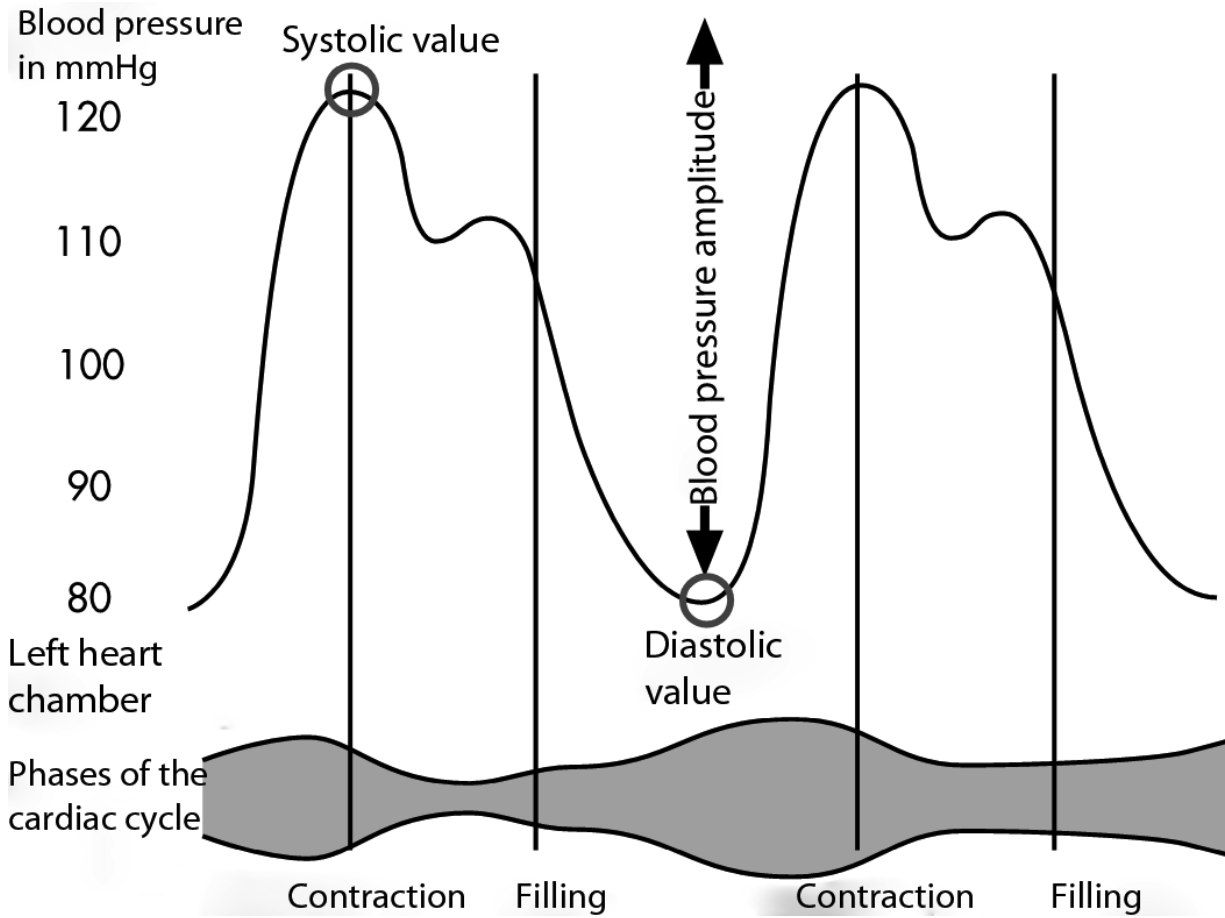

Measuring blood pressure

Everybody's blood pressure changes constantly. Fluctuations may be caused by mental and physical factors (such as diet, exertion, smoking, caffeine or stress). Blood pressure can also be affected by the time of day, time of year or temperature.

This blood pressure measuring device helps you to take regular, comparative measurements. Individual, irregular measurements are therefore not very meaningful. The guidelines for normal and high blood pressure (diastolic and systolic value) have been defined by the World Health Organization (WHO) as shown in the following table.

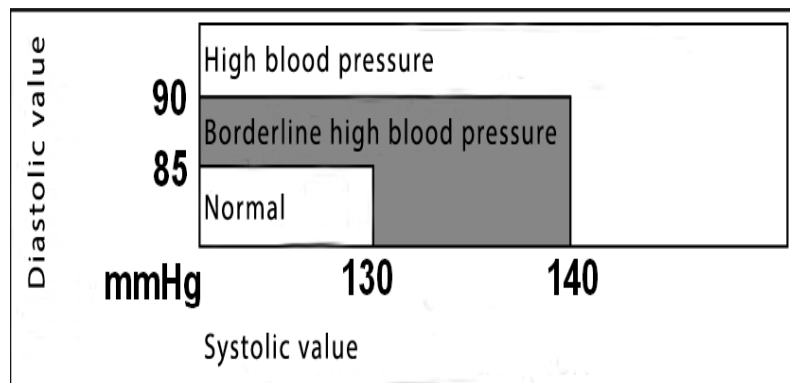



Before taking your blood pressure measurement



Using this device, you can get an overview of your blood pressure by measuring it regularly and keeping clear records.

To make sure that the values give a realistic picture of your blood pressure, please follow the instructions below:

- Measure your blood pressure several times during the day.
- Always measure your blood pressure at the same time of day.
- Always take blood pressure measurements under the same conditions. Always use the same arm.
- Measure your pressure when you are relaxed. Try to rest for fifteen minutes before measuring your blood pressure.
- You should wait an hour after a large meal before measuring your blood pressure.
- Do not smoke or drink alcohol before measuring your blood pressure.
- Do not exercise for at least 60 minutes before measuring your blood pressure.
- Do not measure your blood pressure if you are under stress or are tense.
- Measure your blood pressure at normal body temperature, but not if you are too hot or cold.
- Wait approximately five minutes before repeating the measurement.

16





If you record a value that differs greatly from your normal blood pressure measurement, you should take another measurement around five minutes later. This will allow you to rule out any of the factors mentioned above, which could result in an incorrect measurement.

About your measurement results



CAUTION!

If the measurements obtained give you cause to be concerned about your health, consult with your physician or licensed health care professional. Do not change your current treatments and/or dosages of medication(s) as a result of your measurements unless you have discussed this first with your physician.

By using your device regularly and recording your results, you can get a clear overview of your blood pressure. Everybody's blood pressure changes constantly. Fluctuations may be caused by mental and physical factors such as diet, stress, exertion, smoking and caffeine. Blood pressure can also be affected by the time of day, time of year and temperature. In addition, arrhythmia (irregular heartbeat) can lead to imprecise results. In this case, discuss with your physician whether you should be using this device.



How does the blood pressure monitor work

Your blood measuring monitor contains high quality technical components and materials for measuring and to show the results on the display. It also measures and displays your pulse rate.

The blood pressure monitor measures blood pressure indirectly using a cuff around the upper arm. Inflating the cuff presses the arteries together so that no more blood can flow through them. If the pressure in the cuff is then reduced, this creates a relation between the cuff pressure and the blood pressure.

The monitor has electronic step valves that can detect even slight changes during the measurement, which can be evened out using the cuff pressure.

By reducing the pressure step-by-step, fluctuations in the cuff are recorded by the monitor and included in the assessment. If no fluctuations are recorded for a step, the air pressure is reduced. Existing fluctuations are assessed at the corresponding step level until they can be determined precisely.





What's included

The following items were included in the box:

- Blood pressure measurement device
- 2 arm cuffs (standard and XXL cuff)
- 4 x 1.5V batteries type R6/LR6/AA
- Storage bag
- Blood pressure daily log
- Instruction Manual and Quick Start Guide
- Warranty



Overview of the monitor

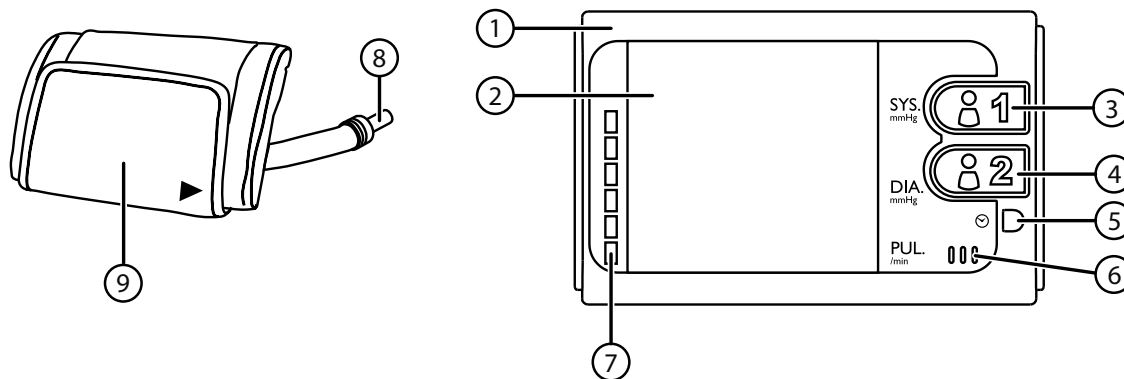

No.	Description	No.	Description
1	Blood pressure measurement device	6	Speaker
2	Display	7	WHO Blood pressure range indicator scale
3	User 1 Button/Set-up key	8	Plug for arm cuff tube
4	User 2 Button/Set-up key	9	Arm cuff
5	Button CLOCK		





Display

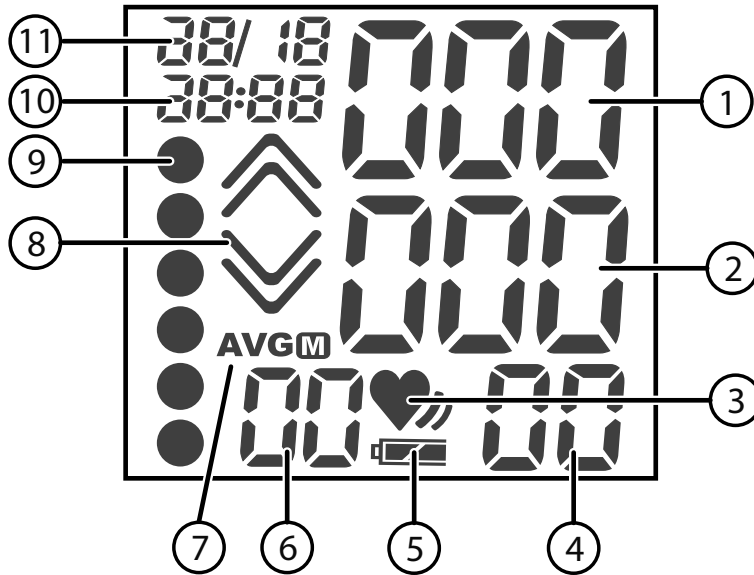



No.	Description
1	Systolic value in mmHg
2	Diastolic value in mmHg
3	Heart beat and irregular heart beat (arrhythmia) detection indicator
4	Pulse rate (heart beats per minute)
5	Battery power remaining
6	Number of stored values
7	AVG (average values)
8	Cuff inflating/deflating indicator
9	WHO blood pressure range indicator display
10	Time
11	Date



Preparing the device

Inserting batteries

- ▶ Open the battery compartment on the bottom.

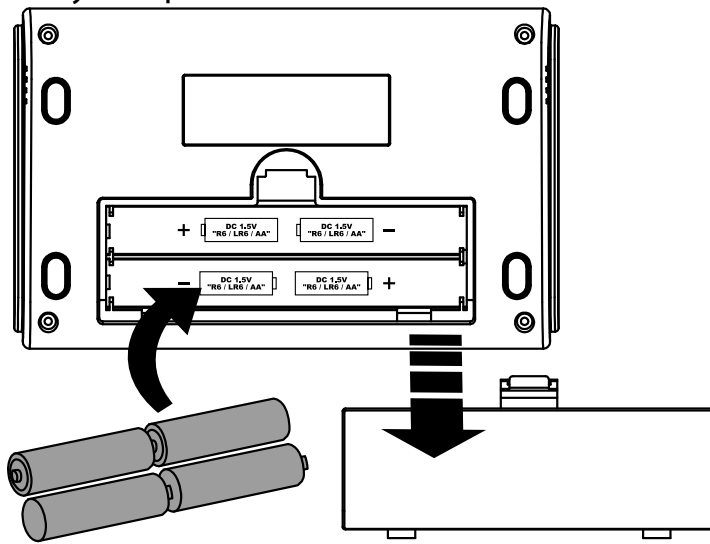



- ▶ Insert four 1.5V batteries of type R6/LR6/AA, observing the correct polarity.
- ▶ Close the battery compartment.

Basic settings must be reset after changing the batteries. See page 25.



NOTE

Existing measurement values will be stored.





Basic Settings

You must make the following basic settings before using the device for the first time or after changing the batteries:

- Volume
- Language
- Year
- Date (month, day)
- Time (hour, minute)
- ▶ Press the TIME button for approximately 3 seconds.



NOTE

If you do not press any buttons for approximately 10 seconds, the monitor will switch into standby mode.



The volume display flashes.

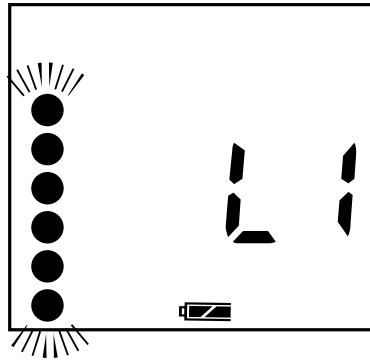

- ▶ To increase the volume, press button 1.
- ▶ To decrease the volume, press button 2.

After pressing the button you will hear a confirmation tone in the corresponding volume.

- ▶ Press the TIME key.





The language setting display flashes.

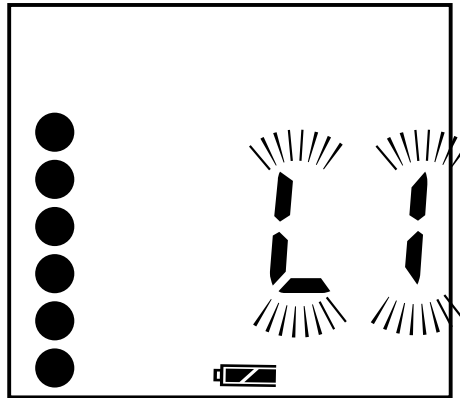

- ▶ This monitor can provide your measurement results verbally. To select your language, choose from the list below. Then, using buttons 1 or 2, scroll up or down until you find the abbreviation next to your desired language in the table below.
- ▶ If you want no language output, select **L0**.

Display	Language
L1	German
L2	English
L3	French
L4	Turkish
L0	No language output





- ▶ Press the TIME key.

The digits indicating the year will flash.



- ▶ To set the required year, press User 1 button to advance or User 2 button to move backward.

- ▶ Press the TIME key.

The digits indicating the month will flash.

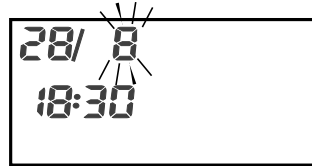

- ▶ To set the required month, press User 1 button to advance or User 2 button to move backward.

- ▶ Press the TIME key.

The digits indicating the day will flash.

28



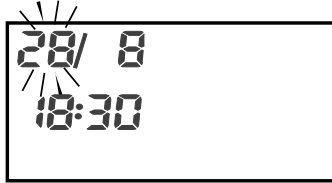

- ▶ To set the required day, press User 1 button to advance or User 2 button to move backward.
- ▶ Press the TIME key.

The digits indicating the hours will flash.

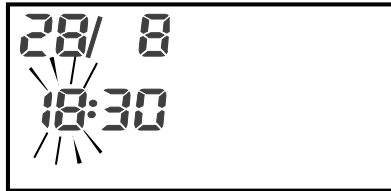

- ▶ To set the required hour, User 1 button to advance or User 2 button to move backward.
- ▶ Press the TIME key.

The digits indicating the minutes will flash.



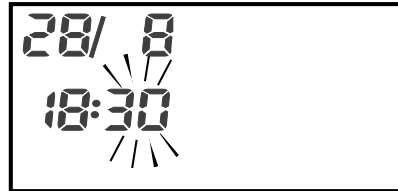

- ▶ To set the required minutes, press User 1 button to advance or User 2 button to move backward.
- ▶ Press the TIME key.

The settings you have made are saved.

You will see the following display:

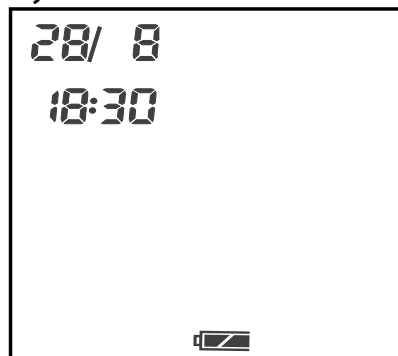



Switch device on and off

- ▶ Press either User 1 or User 2 button to switch on the monitor.
The corresponding button will light up.
The measurement starts automatically.
- ▶ Press User 1 or User 2 button again to switch off the monitor.
Press the TIME button to switch the monitor into standby mode.
The monitor is in standby mode.

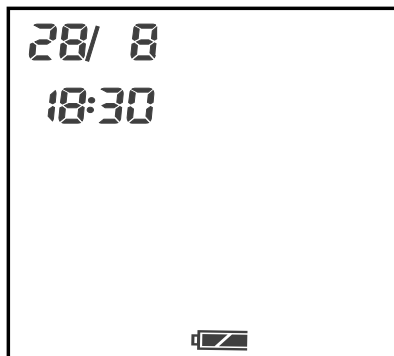

The monitor will switch off if you do not press any buttons for approximately 2 minutes.





Measuring your blood pressure and pulse

Putting on the cuff

The cuff is suitable for an arm circumference of 8.6 to 12.6 inches.

- ▶ Remove any watches, jewellery etc.

The upper arm must be exposed because the cuff must lie directly on the skin.

- ▶ Do not roll up tight shirt sleeves, as this will squash the arm and could produce an inaccurate measurement.
- ▶ Remove this item of clothing if the shirt sleeves cannot easily be rolled up.

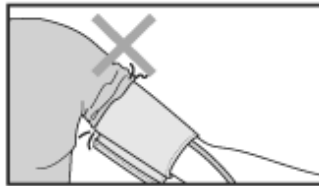

- ▶ Pull the end of the cuff through the frame at the other end.
The Velcro fastener must face out.



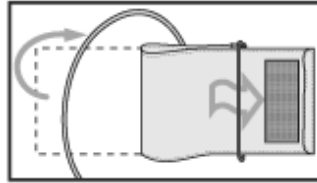

- ▶ Pull the cuff over the arm so that the tube lies over the top of the upper arm, in the direction of the underarm. The blue mark on the cuff points to the hand.

The bottom edge of the cuff must end 0.8 to 1.2 inches above the elbow.

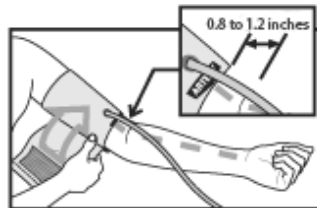

- ▶ Pull on the cuff and fold down its ends.
- ▶ Secure the end with the Velcro fastener.





The cuff is in the right position on the arm:

- When there is room for one finger between the cuff and the arm,
- When it sits securely and doesn't slip.



The cuff must not be too tight because the pressure on the arm will increase further when the cuff is pumped up.

If the shape of the arm does not allow the cuff to be wrapped around it properly, the cuff can sit at a slight diagonal.

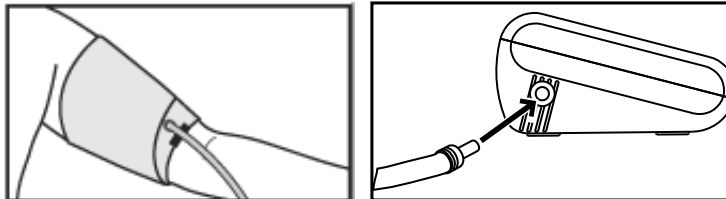

- ▶ Stick the cuff's tube plug into the connection provided on the monitor.





Posture

- ▶ To measure your blood pressure you should be sitting comfortably on a chair.
- ▶ Take five or six deep breaths and relax.
- ▶ Rest your elbows on the table or other surface.
- ▶ Hold your arm so that the cuff is level with your heart.
- ▶ Relax your arm and turn up the palm of your hand.

You can also take the measurement lying down:

- ▶ Lie on your back.
- ▶ Rest your arm alongside your body.
- ▶ Have your palm facing up.

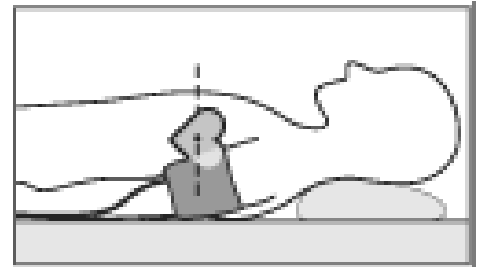
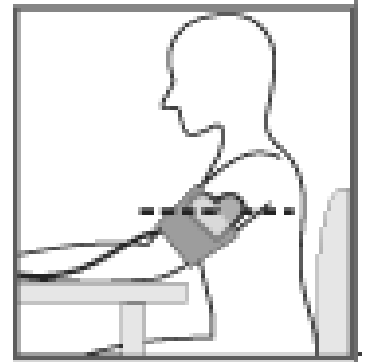



Measuring and storing values

If you know that your blood pressure is higher than 230mmHg, proceed as described on page 38.

- ▶ Press button 1 or 2 to interrupt the measurement.
- ▶ Make sure that the air tube is not kinked or being squashed.



NOTE

You can save 30 measurement values for each of two users in separate memories.

- ▶ To store the values for the first user, press button 1.
- ▶ To store the values for the second user, or, if only one person uses this monitor to store additional values, press button 2.

The selected button will light up.

- ▶ During measurement, do not move the cuff or your arm or hand muscles.

After a few seconds, the monitor will pump up the cuff. When the cuff pressure is stable, the monitor will start measuring automatically.

The current values are shown in the display.

- ▶ Press button 1 or 2 if you want to interrupt the measurement.

The cuff deflates.

36





- ▶ If you want to repeat the measurement, you should wait at least five minutes.

The cuff must be fully deflated.

Measurement starts when the correct cuff pressure has been reached. The monitor also measures your pulse. The value displayed will fall during measurement.

If the cuff pressure is too low, the monitor stops measuring and inflates the cuff again until sufficient cuff pressure is reached for the measurement.

The cuff deflates when the measurement is complete. The systolic and diastolic blood pressure and the pulse with the pulse symbol appear on the display.

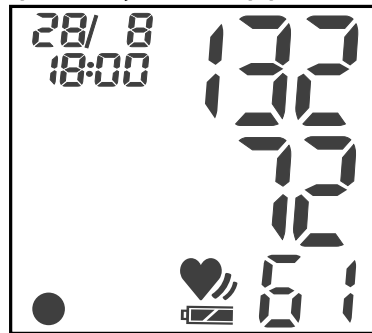

The values measured will be automatically stored with the date and time once measuring is complete. 30 storage spaces are available, whether you start measuring using button 1 or 2. Two people can record their values separately, for example. If there are more than 30 measurements, the oldest value will be overwritten.





Irregular heartbeat (arrhythmia) detection

Normally, the pulse beats with a regular rhythm (rhythmically). When the device detects an abnormal pulse rhythm, the ♥// symbol appears on the display.

In this case, repeat the measurement.

Abnormal pulse rhythms can have different causes. If the pulse is constantly arrhythmic, please consult your physician or licensed healthcare provider.

Measuring without storing values

You can also measure your blood pressure without storing the values.

▶ To do so, press button 1 or 2 at the same time.

The buttons light up.

The measurement is taken as described above.

The values measured are not saved.

Taking measurements if your blood pressure is higher than 230mmHg

If your blood pressure is higher than 230mmHg you must pump up the cuff manually.





NOTE

User 1 and User 2 button are used interchangeably in the following description.

If you want to store the values in memory 1, use the first button mentioned for each action.

If you want to store the values in memory 2, use the second button mentioned.

- ▶ Press User 1 or User 2 button and hold the button down for approximately 3 seconds.

The average values of the last three measurements from the selected memory will be shown in the display.

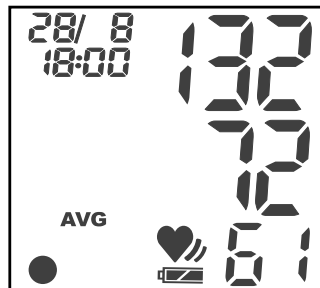

- ▶ Press User 1 or User 2 button and hold the button down for approximately 3 seconds. The de-pressurisation symbol will be shown.



- ▶ Wait until "0" is shown on the display.

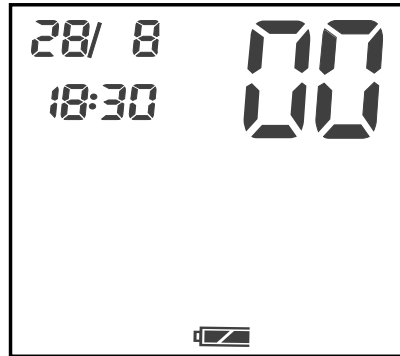

- ▶ Press User 1 or User 2 button and hold it down until the required starting value has been reached, e.g. 250mmHg.

The measurement is taken.

The values measured are saved.



Classifying blood pressure

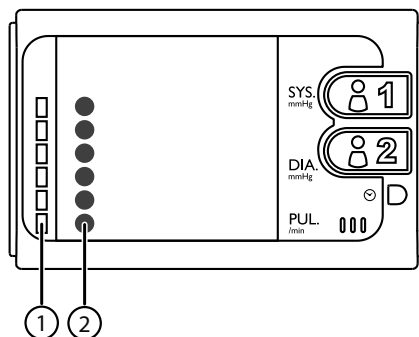

- 1 WHO blood pressure range indicator scale
- 2 WHO blood pressure range indicator display

The colored bar chart to the left of the display has the following meanings:

Color	Explanation	SYS. [mmHg]	DIA. [mmHg]
red	Severe high blood pressure	Above 181	Above 111
light red	Moderate high blood pressure	161 to 180	101 to 110
orange	Mild high blood pressure	141 to 150	91 to 100
yellow	Borderline high blood pressure	131 to 140	86 to 90
green	Normal blood pressure	121 to 130	81 to 85
light green	Optimum blood pressure	Below 120	Below 80



Retrieving saved measurements

Retrieving average measurements

Proceed as follows to retrieve the average values of the last three measurements:

- ▶ Press User 1 or User 2 button and hold the button down for approximately 3 seconds.

The average values of the last three measurements from the selected memory will be shown in the display.

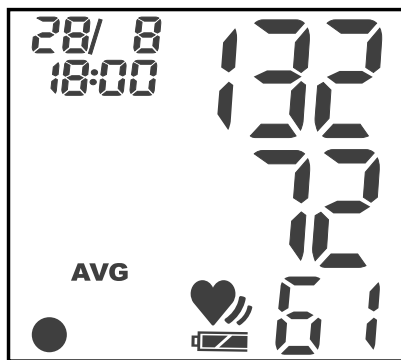

If you have switched on language output, this value will also be given verbally.





Retrieving values of individual measurements

Saved measurement values can be displayed.

- ▶ To retrieve the measurements stored in User 1 memory, press button 1 and hold it down for approximately 3 seconds.
- ▶ To retrieve the measurements stored in User 2 memory, press button 2 and hold it down for approximately 3 seconds.

The average values of the last three measurements from the selected memory will be shown in the display.

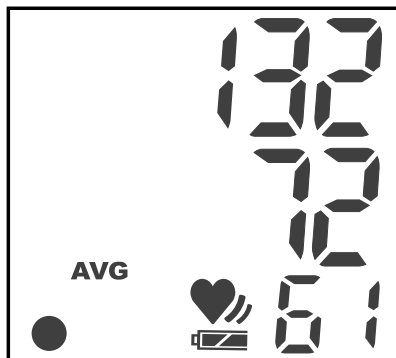

If you have switched on language output, this value will also be given verbally..

- ▶ Press button 1 or 2 to call up the stored values individually. You can scroll through the newest to the oldest values by pressing the button.



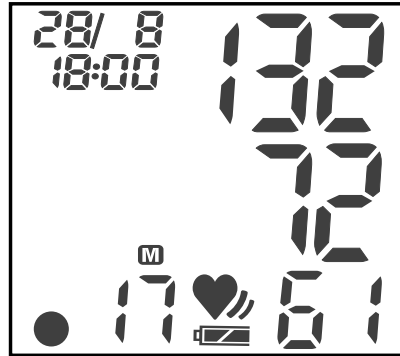

If you have switched on language output, this value will also be given verbally.

- ▶ To switch off the monitor, press the corresponding button for approximately three seconds.

Deleting the values of a user

- ▶ Press button 1 for deleting User 1 memory (or button 2 for deleting User 2 memory) and hold it down for approximately 2 seconds.
- ▶ Press button 1 (or button 2) again to get into the menu.
- ▶ To clear all values of the User 1 memory (or User 2 memory), press button 2 and 1 and hold it down simultaneously until **CLOO** is displayed.



Error messages and troubleshooting

Error message	Possible cause	Remedy
E1	Pulse rate measurement has failed.	Put the cuff on correctly and take the measurement again.
E2	Measurement has failed because you moved or spoke.	Keep still and do not speak during measurement.
E3	The cuff is not in the right position on the arm.	Put the cuff on correctly and take measurement again. See page 32.
E4	Measurement error	Put the cuff on correctly and take the measurement again. See page 32.
E5	The pressure is beyond the measurement range.	Read the instructions on measuring correctly. See page 16. Measure again after 5 minutes.
E6	The battery power is too low.	Insert four new batteries. See page 23.
The battery symbol flashes	The battery power is low.	Insert four new batteries. See page 23.



Error message	Possible cause	Remedy
The results of measurement are abnormally high or too low.	The cuff is not at heart level.	Read the instructions on measuring correctly. See page 16.
	The cuff is not in the right position on the arm.	Put the cuff on correctly. See page 32.
	The cuff tube is not connected correctly to the monitor.	Attach the cuff's tube plug correctly to the monitor.





Cleaning, storing and servicing your blood pressure monitor

- ▶ Only use a dry, soft cloth to clean the monitor. Do not use chemical solutions and cleaning products as these may damage the monitor's surface and/or inscriptions.
- ▶ Do not wash the cuff. Do not have the cuff dry-cleaned.
- ▶ If the monitor is not going to be used for long periods, remove the batteries.
- ▶ Put the monitor in its original box for storage and transport.

It is recommended that you check the operability of the monitor at least every three years.





Disposal

Packaging

Your monitor has been packaged to protect it against transportation damage. The packaging is made of environmentally friendly material which can be recycled.

Monitor

At the end of its life, this device should not be disposed of in household trash. Enquire about the options for environmentally friendly disposal.

Batteries

Do not throw used batteries out with your household trash. Take them to a recycling center for old batteries.





Technical specifications

Measurement method	Oscillometric
Blood pressure measurement range	30 to 250mmHg
Pulse measurement range	40 to 180 beats/minute
Blood pressure measurement accuracy	± 3 mmHg
Pulse measurement accuracy	$\pm 5\%$ of value displayed
Number of storage spaces	2 x 30
Cuffs for arm circumference	8.6 to 12.6 inches (standard cuff) 12.6 to 17.3 inches (XXL cuff)
Operating conditions	Temperature: +50 to +104°F Relative humidity: 30 to 85%
Storage conditions	Temperature: -4 to +140°F Relative humidity: 10 to 95 %
Power supply	4 x 1.5V batteries of type R6/LR6/AA.

Specifications subject to change without notice.





FCC Statement

NOTE:

POTENTIAL FOR RADIO/TELEVISION INTERFERENCE (for U.S.A. only)

This product has been tested and found to comply with the limits for a Class B digital device, pursuant to Part 15 of the FCC rules.

These limits are designed to provide reasonable protection against harmful interference in a residential installation. This equipment generates, uses and can radiate radio interference energy and, if not installed and used in accordance with the instructions, may cause harmful interference to radio communications. However, there is no guarantee that interference will not occur in a particular installation. If this equipment does cause harmful interference to radio or television reception, which can be determined by turning the equipment off and on, the user is encouraged to try to correct the interference by one or more of the following measures:

- Reorient or relocate the receiving antenna.
- Increase the separation between the equipment and the receiver.
- Connect the equipment into an outlet or on a circuit different from that to which the receiver is connected.
- Consult the dealer or an experienced radio/TV technician for help.

50





You may also find helpful the following booklet, prepared by the FCC: "How to Identify and Resolve Radio-TV Interference Problems." This booklet is available from the U.S. Government Printing Office, Washington D. C. 20402.

Changes or modifications not expressly approved by the manufacturer or registrant of this equipment can void your authority to operate this equipment under Federal Communications Commissions rules.

Status: 08/2012





Limited Warranty

PLEASE READ THIS LIMITED WARRANTY CAREFULLY TO UNDERSTAND YOUR RIGHTS AND OBLIGATIONS.

MEDION warrants that the Welby® Premium Wrist Blood Pressure Monitor (MD 12450, Item 90115) accompanied by this limited warranty is free from manufacturing defects in material or workmanship for a period of 36 months from the date of original purchase. Please save your original cash register receipt as it may be required to validate original date of purchase. The limited warranty period also applies to any implied warranties that may exist under applicable law. Some States do not allow limitations on how long an implied warranty lasts, so the above limitation may not apply to you.

This limited warranty does not apply to products that have been opened, repaired (except by MEDION or its authorized Service representatives), or otherwise altered. This limited warranty does also not apply to defects resulting from misuse, abuse, accident, neglect, improper maintenance or handling.

If you believe the product is defective please return it to MEDION in the manner described below within the limited warranty period. If MEDION determines a defect covered by this limited warranty, MEDION will, at its option, repair or replace the product. This limited warranty extends to repaired products and replacement products

52





only through the end of the original limited warranty period.

In no event shall MEDION or any of its distributors or resellers be liable for incidental, indirect or consequential damages relating to the product (including any repaired product or replacement product) or its use. Some States do not allow the exclusion or limitation of incidental or consequential damages, so the above limitation and exclusion may not apply to you.

This limited warranty gives you specific legal rights, and you may have other rights which vary from State to State.

To make a claim under this limited warranty you must first contact MEDION Customer Care using one of the options below to obtain a return merchandise authorization (RMA) number. Once you have received the RMA, please return the product as instructed by the RMA. This warranty does not apply to any products returned to MEDION without a RMA.

To obtain a RMA please contact MEDION Toll Free Customer Care at:

866-633-4660

Daily 8:00 am - 8:00 pm CST

except holidays

Web Support (Available 24 x 7, with response generally within 24 hours)

www.medion.us







Model: MD 12450 / 90115

<p>AFTER SALES SUPPORT</p> <hr/> <p> 866-633-4660</p> <hr/> <p>MODEL: MD 12450 / ITEM CODE# 90115 / 02/2013</p>	<p>3</p> <p>YEAR LIMITED WARRANTY</p>
--	--

Daily 8:00 am - 8:00 pm CST
except holidays

