

Sigma

Industrial Remote Controller

OPERATION GUIDE

Sigma S300 -6 single step buttons

Sigma S400 -8 single step buttons

Σ Sigma makes convenience!!

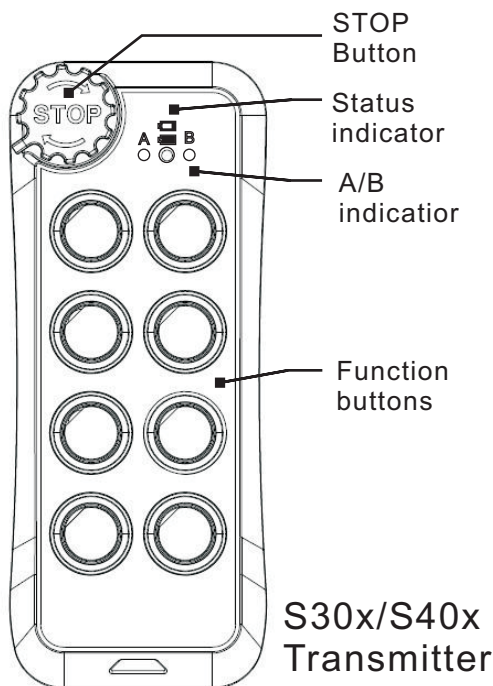

Σ Transmitter specification-

Frequency range :

419.2MHz

Transmitting power : <0.03mW

Transmitting mode : F1D

Modulation mode : FSK

Security codes : 4.2billion sets

Power source :

2 x AA (LR6) 1.5V alkaline batteries

Power consumption : < 8mA

Operation temperature :

-10°C ~ + 40°C

Enclosure rating: IP60

Size : S30x / S40x

175mm X 70mm X 43mm

S50x / S60x

230mm X 70mm X 43mm

Weight: S30x / S40x 250g

S50x / S60x 310g

(batteries included)

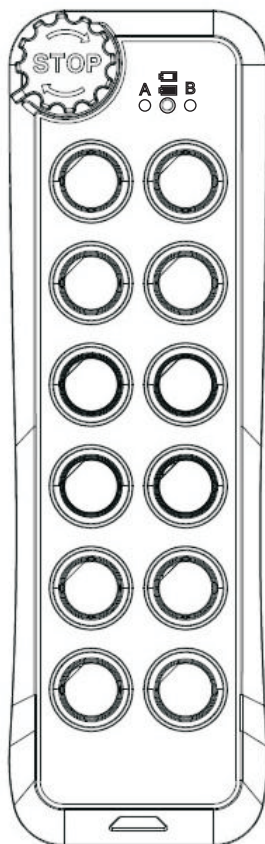

Σ Indicators of transmittor-

1. Red ON(2sec) : When STOP Button is pressed down, the Red LED would light on 2 secs. Now it is in the STOP Mode.
2. Green ON : After clockwise turning ON the STOP button, press any button(or press the Start-up Button, it depends on the set up) then the Green LED would light on. It is in the Start-up Procedure.
3. Green flash : During operation, the Green LED would flash every 2 secs.
4. Red flash : During operation, if the Red LED flashes per sec., it is telling you that the battery power is low. Please renew 2 x AA alkaline batteries.
5. A/B indicator : In the type S40xAB, S50xAB and S60xAB, this indicator can show which hoist (A and/or B) is controlled.

Σ Sigma makes convenience!!

Σ Receiver specification-

Frequency range : 419.2MHz

Receive Sensitivity : $< -115\text{dBm}$

Security codes : 4.2billion sets

Contacts ability : 5A @ 250VAC

Power source : AC 110 V

Current rating : 0.5 A

Power consumption : $< 8\text{W}$

Operation temperature :
 $-10^{\circ}\text{C} \sim +40^{\circ}\text{C}$

Enclosure rating: IP60

Size : S30x / S40x

220mm X 120mm X 75mm

S50x / S60x

240mm X 120mm X 90mm

Weight : S30x / S40x 760g

S50x / S60x 950g

(Cable excluded)

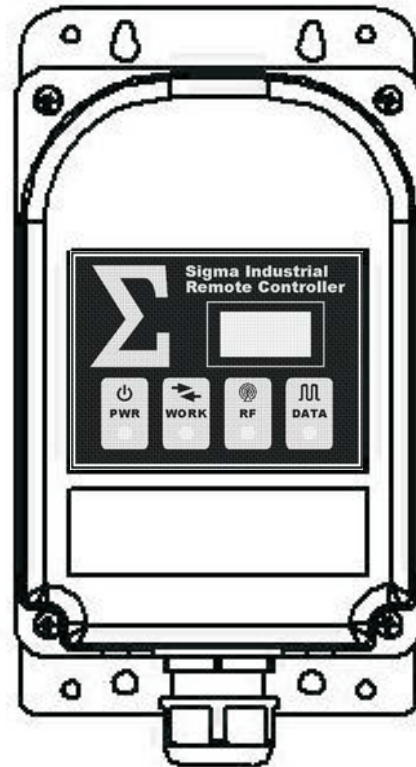

S30x/S40x Receiver

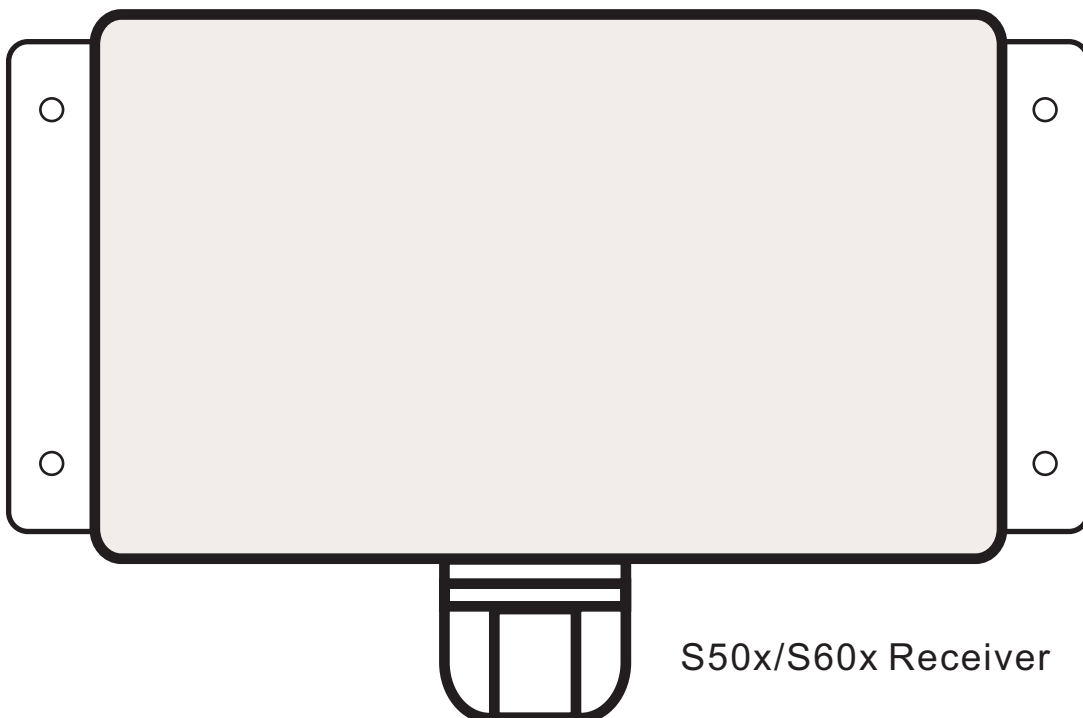

S50x/S60x Receiver

Σ Sigma makes convenience!!

Σ Indicators of receiver -

1. **PWR**(Green) :
Power indicator. It lightens on when the power is fed in.
2. **WORK** :
Green ON - The Receiver got the Start-up command, and is in Working Mode, ready for the operation anytime.
Green OFF - The Receiver is still in the Stand-by Mode, and it needs to receive the Start-up command to operate.
Red Flash - The Receiver is in the Security Code Learning Mode.
3. **RF** :
Red ON - The RF signal is received.
Red OFF - Non RF signal or low signal.
4. **DATA** :
Red ON - The Receiver is waiting for the RF signal.
Red OFF - The RF signal received and decoded correctly.
Red fast Flash - 5 times/sec , The RF Signal received, but the Security Code does not match with each other.
Red slow Flash - 1 times/sec, The RF signal received, but it is not Sigma's Code. The receiver is interfered by other RF signals.

Σ Opration of Sigma-

Start up -

1. Power on the receiver and check the **PWR LED** lightening or not.
2. Turn the **STOP** Button clockwise and release, the **STOP** will spring up. (Please placed batteries into the transmitters at first, if have't placed batteries)
3. Push any button, or the **Start-up** Button (if already set by **Set-up program**). Wait till the Transmitter indicator **Green LED** lightenen, and the Transmitter will send the **Start-up** command to the Receiver. Mean time, if the Receiver got the **Start-up** command, its **WORK LED** will lighten. Release the pressed button(s), and the transmitter's **Green LED** will be off.
4. It is ready, and you can operate **Sigma** now.

Power off -

1. Push down the **STOP** Button anytime, the transmitter will send out the **STOP** command to the Receiver. The Receiver will cut down any output, and the **WORK LED** should be shut off. The transmitter's **RED LED** will still lights on and sending **STOP** command 2 secs.
2. Now, you may power off the Receiver.

Σ **Sigma makes convenience!!**

Σ **Cautions-**

- ① If you are not a professional, please do not install or uninstall **Sigma**. The equipments (or/and **Sigma**) would be damaged from your errors.
- ② The equipments must have the **Main Power N.F.B., Main Power Relay, Limits SW.....**, and other safety protecting equipments.
- ③ To avoid the influence caused by electromagnetic wave, the location of receiver should be away from motor/converter/welding machine and so on which may bring it.
- ④ The **Sigma's** receiver should not be mounted inside of any metal box. It will weaken the strength of the RF signals, and may cause bad receiving condition for your operation. The receiver should be mounted outside of any metal box or other safe places that wouldn't cause bad receiving condition.
- ⑤ If you will not use **Sigma** for a long time, about a week or more, the batteries should be taken off to prevent the batteries electrolyte leakage to etch the **PCB**.
- ⑥ For PERMANENTLY CONNECTED EQUIPMENT, a readily accessible disconnect device shall be incorporated external to the equipment.

Σ Sigma makes convenience!!

Σ Sigma Functions -

1. Interlocked -

Left/ right button is interlocked from each other.

2. Non_Interlocked -

Left/ right button is not interlocked, and its Two kinds of movements as below.

① **Normal** - Push down is **ON**, and release to be **OFF**.

② **Toggle** - Push down would output **ON**. Release and push down again, output **OFF**. (This function could be set by passing EMS.)

3. ON/OFF -

In this Function, you can set the Left/ Right Button as **ON/ OFF** function. The Left Button as **OFF**, and the Right Button as **ON**. (This function could be set by passing EMS.)

4. Special 2nd Step -

This function only supports the Special Two Step Button, and the movement is like the below diagram.

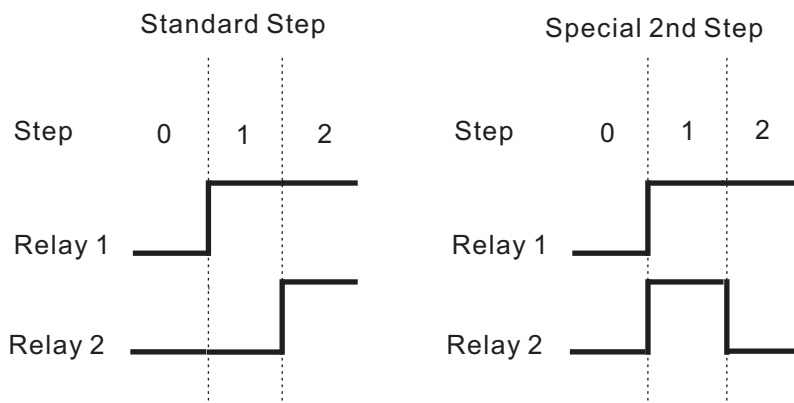

5. A/B Selector -

This Function only supports **Button H** in S40xAB, **Button J** in S50xAB and **Button L** in S60 x AB, as the A/B Selector to choose **Hoist A**, **Hoist B**, or A + (plus) B to work together. The moves in turns like this, **OFF -> A-> A+B -> B -> OFF** (Repeatedly). At the transmitter, it has the corresponding **LED A/ B** to indicate which Hoist being controlled.

6. Start Up mode -

For the safety and convenience, Sigma has 2 kinds of Start-up Mode.

① Any button to start up - More convenience, but less safety.

② Specified button to start up - In S4xx, press **G + H** at the same time, in S5xx, press **I + J**, while in S6xx, press **K + L** to start-up Sigma.

This mode could prevent from starting-up by mistake. It provides you more safety.

Σ Sigma makes convenience!!

7. Working Mode -

Sigma has 2 kinds of Working Modes to meet the need of various working places.

- ① **No Auto Stop** - During operation, the Transmitter would not be shut down automatically. You need to press the **STOP** Button for shutting **Sigma** down.
- ② **Auto Stop** - After starting up, the Transmitter could be automatically shut down after the set time-out period.

Notes -

*1 - In the previous ② **Auto Stop** mode and **mode**:

The Transmitter consistently consumes power all the time. You need to additionally set up the **Auto Stop** time. It can be selected among 3, 1, 2, 5, 10 minute(s) for shutting down the Transmitter. To resume the operation, you can press the **STOP** Button at first, then release it to spring-up---- if the **Auto Stop** occurred.

*2 - Working Modes are for you to choose among Safety, Power Consumption, and Convenience. The below table is for your reference.

	No Auto Stop	Auto Stop
Safety	Low	Middle
Power Consumption	Low	Middle
Convenience	High	Low

Σ Sigma makes convenience!!

Sigma S300 series installation wiring diagram

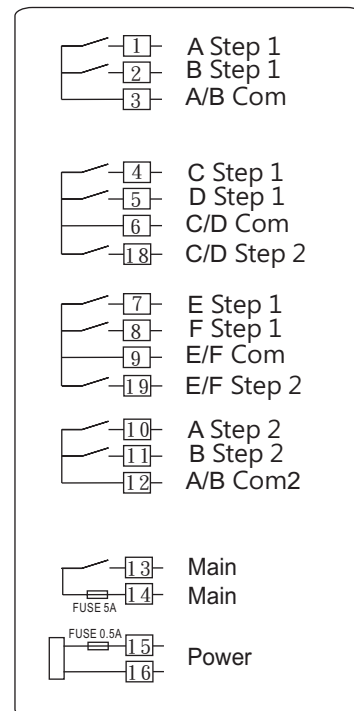
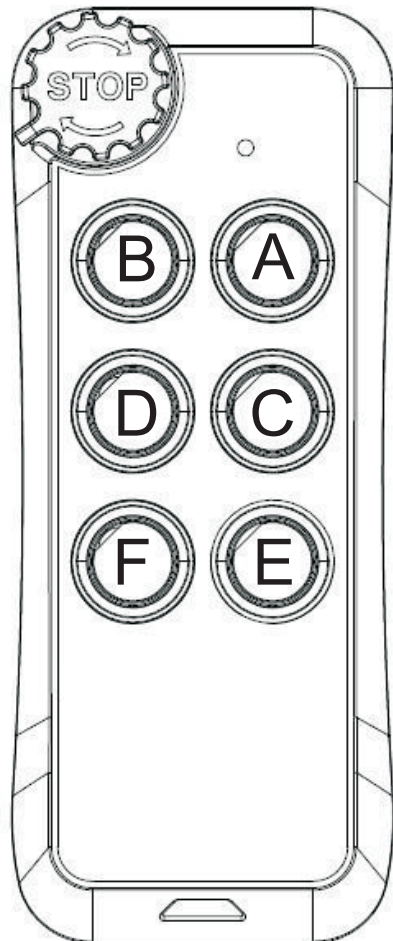

Sigma S300 series wiring

Σ Sigma makes convenience!!

Sigma S400 series installation wiring diagram

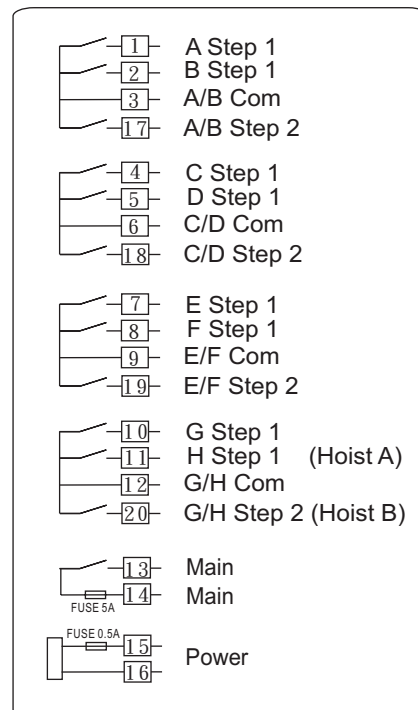
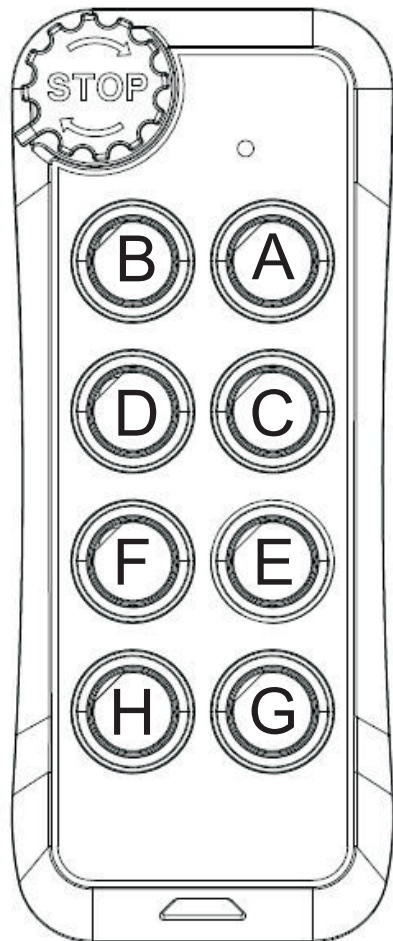

Sigma S40x series wiring

You are cautioned that changes or modifications not expressly approved by the party responsible for compliance could void your authority to operate the equipment.

This device complies with part 15 of the FCC rules. Operation is subject to the following two conditions

- (1) This device may not cause harmful interference and
- (2) this device must accept any interference received, including interference that may cause undesired operation.

Note: This equipment has been tested and found to comply with the limits for a Class A digital device, pursuant to part 15 of the FCC Rules. These limits are designed to provide reasonable protection against harmful interference when the equipment is operated in a commercial environment. This equipment generates, uses, and can radiate radio frequency energy and, if not installed and used in accordance with the instruction manual, may cause harmful interference to radio communication. Operation of the equipment in a residential area is likely to cause harmful interference in which case the user will be required to correct the interference at his own expense.