

Cellular Specialties, Inc.

Model 565_{AMPS} In-Building Amplifier

Installation and Users Manual



The serial number may be found on the label on the rear panel of the unit. For your convenience, note this number below, and retain this manual, along with proof of purchase, to serve as a permanent record of your purchase in the event of a theft, or for future reference.

MODEL NUMBER

565

DATE OF PURCHASE

SERIAL NUMBER

NAME OF COMPANY



FCC ID: NVRBA56X-02

IC: 4307A-BA56X8

THIS DEVICE COMPLIES WITH PARTS 22 AND 2 OF THE FCC RULES, AND WITH INDUSTRY CANADA SPECIFICATION RSS-131.

The term "IC" before the certification/registration number only signifies that the Industry Canada specifications were met.

DISCLAIMER

All information and statements contained herein are accurate to the best of the knowledge of Cellular Specialties, but Cellular Specialties makes no warranty with respect thereto, including without limitation any results which may be obtained from the products described herein or the infringement by such products of any proprietary rights of any persons. Use or application of such information or statements is at the user's sole risk, without any liability on the part of Cellular Specialties, Inc. Nothing herein shall be construed as license or of recommendation for use, which infringes upon any proprietary rights of any person. Product material and specifications are subject to change without notice. All sales of the product or products described herein are subject to Cellular Specialties' standard terms of sale and the specific terms of any particular sale.

TABLE OF CONTENTS

1.0 SAFETY GUIDELINES	3
2.0 PRODUCT DESCRIPTION	4
MECHANICAL OUTLINE DRAWING	5
3.0 GENERAL SPECIFICATIONS	6
4.0 INSTALLATION	7
5.0 AMPLIFIER ADJUSTMENT	9
6.0 TROUBLESHOOTING	10



The general safety information in this guideline applies to both operating and service personnel. Specific warnings and cautions will be found in other parts of this manual where they apply, but may not appear in this summary. Failure to comply with these precautions or specific warnings elsewhere in the manual violates safety standards of design, manufacture, and intended use of equipment. Cellular Specialties, Inc. assumes no liability for the customer's failure to comply with these requirements.

➤ **GROUNDING**

This amplifier system is designed to operate from single-phase 120VAC power and should always be operated with both the neutral and ground wires properly connected. Do not remove or otherwise alter the grounding lug on the power cord.

➤ **EXPLOSIVE ATMOSPHERES**

To avoid explosion or fire, do not operate this product in the presence of flammable gases or fumes.

➤ **LIGHTNING DANGER**

Do not install or make adjustments to this unit during an electrical storm.

➤ **NO USER SERVICEABLE PARTS INSIDE**

HAZARDOUS VOLTAGES ARE PRESENT WHEN THE COVER IS REMOVED. Opening the chassis will void your warranty. If you suspect a malfunction with this product, call your dealer or the Cellular Specialties Support Line at (603) 626-6677.

Cellular Specialties, Inc. developed the Model 565AMPS Bi-Directional Amplifier (BDA) for use in enclosed structures where sufficient signal from local cell sites to operate cell phones was unavailable within the building. It is necessary that sufficient signal be available on the roof of the structure. The BDA is connected to an external antenna, usually on the roof, and to one or more internal antennas placed strategically throughout the area where phone service is desired.

The external antenna is an omni-directional antenna. Internal antennas are usually omni-directional although various other types may be used for certain installations. The BDA amplifies both the "uplink" (phone to tower) and "downlink" (tower to phone) signals thus facilitating communications to and from the local cell site.

There are four amplification stages on the downlink and four on the uplink for a total of +65dB nominal gain for each link. Both links have manual gain control settings accessed through DIP switches on the rear of the unit plus an AGC control for both the uplink and downlink. There are LED indicators for power on, transmitter on, uplink overload and downlink overload.

An automatic amplifier safety shutdown circuit is also provided, which will disable the transmitters for ten seconds should the uplink or downlink overloads be reached to prevent excessive intermodulation and oscillation.

The BDA is equipped with an interface connector designed for use with the optional CSI-MHH External Monitor. The pin-out of the MONITOR connector is shown below.

Pin	Description
1	Alarm Relay - Common
2	N/C
3	Shutdown (Input TTL)
4	Uplink Power
5	Alarm Relay – Active Open
6	N/C
7	Uplink AGC Level
8	Ground
9	Alarm Relay – Active Closed
10	N/C
11	Downlink AGC Level
12	+5 VDC
13	Uplink Overload
14	Downlink Overload
15	Downlink Power

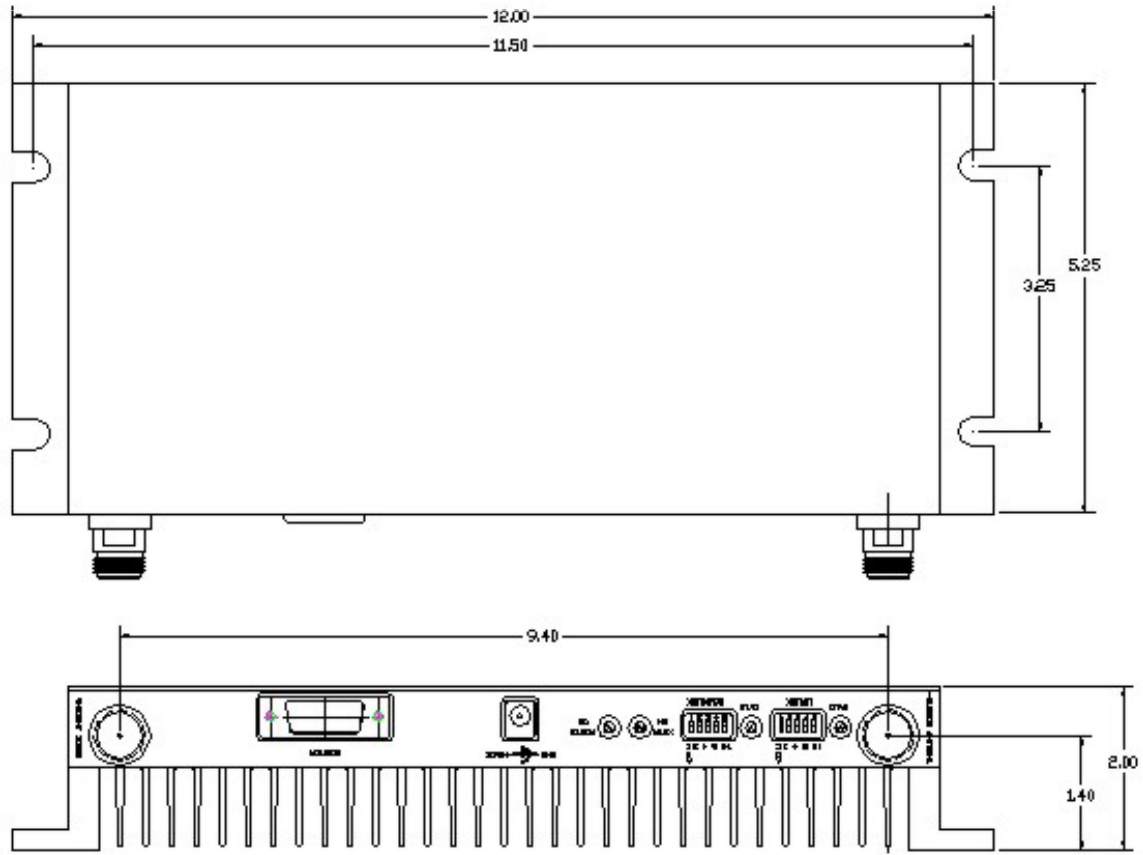

OUTLINE DRAWING

3.0

GENERAL SPECIFICATIONS

All specifications stated as typical unless otherwise noted.

	Uplink (Phone to Tower)	Downlink (Tower to Phone)
Frequency (SMR)	824 - 849 MHz	869 - 894 MHz
Pass Band Ripple	±2.5 dB	±2.5 dB
Gain @ Zero Attenuation	+65dB	+65dB
Gain Adjustment Range	-30dB	-30dB
Linear Output Power * **	+27dBm	+27dBm
Noise Figure	4.5dB	4.5dB
Maximum Input Power***	+15dBm	+15dBm
VSWR	1.7:1 Max	
Propagation Delay	<200 nsec.	
Impedance	50 Ohms	
Connectors	'N' Female	
Power Requirements	+5 VDC @ 4000mA	
Size	5.3" x 12.4" x 1.9"	
Weight	8.8 Lbs., 4 kg	
Operating Temperature	0 to +45° C	
Indicator LEDs	Power, Transmitter On, Uplink Overload, Downlink Overload	
Controls	AGC switch, Uplink and Downlink attenuation switches 0-30dB in 2dB steps.	

NOTES

* The manufacturer's rated output power of this equipment is for single carrier operation. For situations when multiple carrier signals are present, the rating must be reduced by 3.5 dB, especially where the output signal is re-radiated and can cause interference to adjacent band users. This power reduction is to be by means of input power or gain reduction and not by an attenuator at the output of the device.

** Maximum total output power without exceeding the FCC allowable emissions of -13 dBm.

*** Maximum safe input power at maximum gain with no damage.

Cellular Specialties, Inc. reserves the right to change these specifications at any time without notice.

CSI recommends that all BDA installations be coordinated through the local wireless provider.

Note:

The Installer should refer to the ***Safety Precautions***, in the following section, for proper antenna selection and installation



WARNING!

AMPLIFIER DAMAGE **WILL** OCCUR IF A HANDSET IS
CONNECTED DIRECTLY TO THE BDA OR THE COAX THAT
LEADS TO THE BDA.

Important note: A high degree of isolation must be afforded to prevent any regenerative feedback in the system. Feedback of this nature causes the amplifier to emit a continuous signal of maximum amplitude and could, in some cases, interfere with normal operation of the cell site. The minimum required isolation of 80 dB can usually be obtained by mounting the outside antenna away from the edges of the roof. The use of window mounts or other non-rooftop mountings should be avoided.

SAFETY PRECAUTIONS



For **INDOOR** use, an Omni-Directional Antenna with a maximum gain of 3 dBi is authorized for use with this unit.

Inside antennas must be positioned to observe minimum separation of 20 cm. (~ 8 in.) from all users and bystanders. For the protection of personnel working in the vicinity of inside (downlink) antennas, the following guidelines for minimum distances between the human body and the antenna must be observed.

The installation of an **INDOOR** antenna must be such that, under normal conditions, all personnel cannot come within 20 cm. (~ 8.0 in.) from any inside antenna. Exceeding this minimum separation will ensure that the employee or bystander does not receive RF-exposure beyond the Maximum Permissible Exposure according to section 1.1310 Limits for General Population/Uncontrolled Exposure.



For **OUTDOOR** use, an Omni-Directional Antenna with a maximum gain of 3dBi is authorized for use with this unit.

Outside antennas must be positioned to observe minimum separation of 20 cm. (~ 8 in.) from all users and bystanders. For the protection of personnel working in the vicinity of inside (downlink) antennas, the following guidelines for minimum distances between the human body and the antenna must be observed.

The installation of an **OUTDOOR** antenna must be such that, under normal conditions, all personnel cannot come within 20 cm. (~ 8.0 in.) from any inside antenna. Exceeding this minimum separation will ensure that the employee or bystander does not receive RF-exposure beyond the Maximum Permissible Exposure according to section 1.1310 Limits for General Population/Uncontrolled Exposure.

Example: Standard Single Internal Antenna System Design

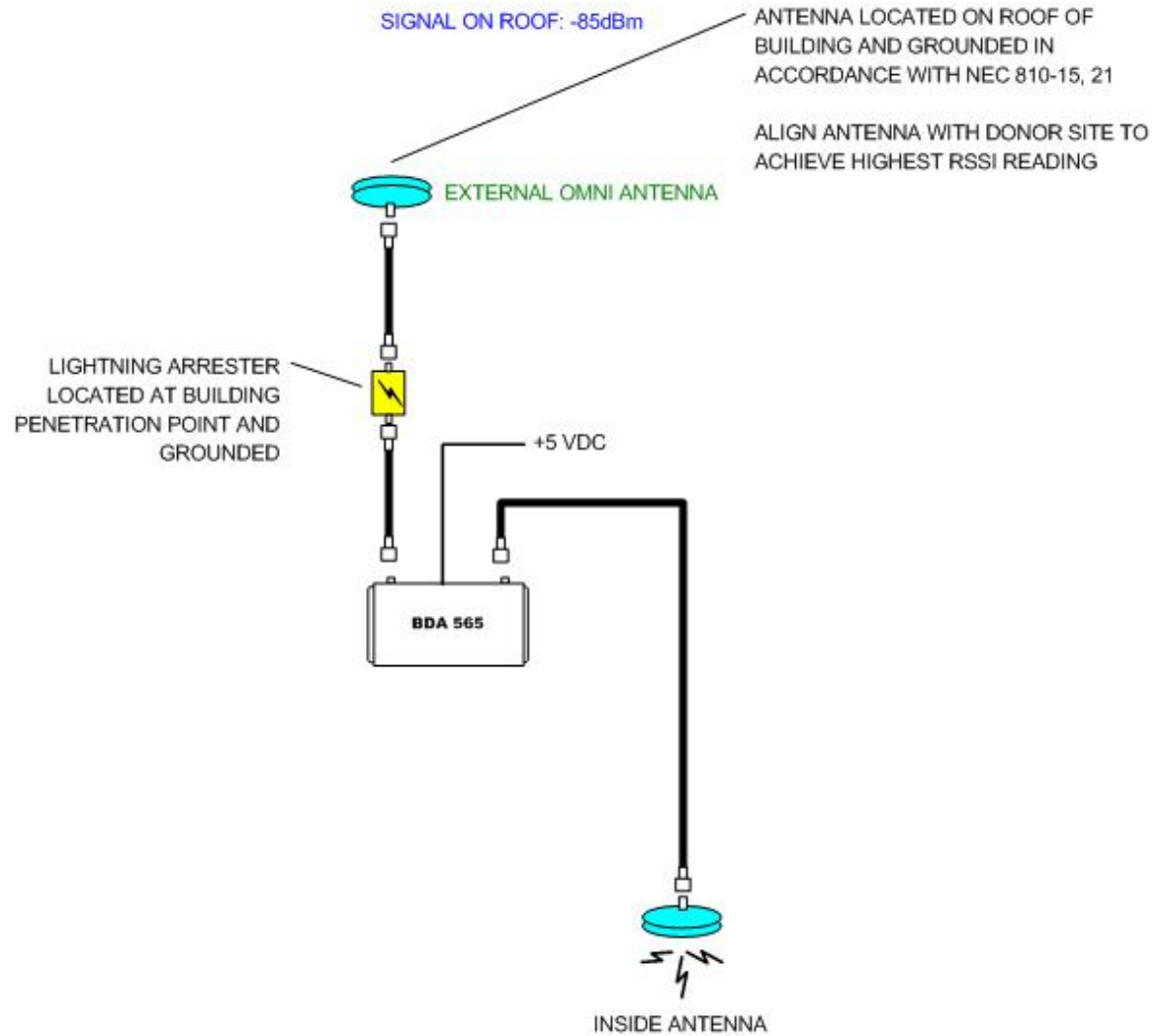

5.0

AMPLIFIER ADJUSTMENT

In most cases the BDA will need very little adjustment. After connecting the coax and powering up the BDA, the signal levels within the previously surveyed areas should be checked for adequate RSSI levels. Measurements should be made at the perimeter of the building both inside and outside. It is important that the RSSI levels measured outside the building remain close to those measured prior to installation of the BDA.

Both the uplink and downlink overload indicators should remain off. If either indicator is illuminated, the gain of the appropriate link should be reduced.

If the gain of the amplifier needs adjustment the uplink and the downlink may be adjusted by means of the step attenuators on the rear of the unit. Attenuation from 0 dB to 30 dB in steps of 2 dB may be inserted by proper selection of the 2, 4, 8 and 16 dB attenuators. If satisfactory cell (or two-way) phone performance is not obtained when the phone is in close proximity to the interior antenna it may be necessary to decrease the gain of one or both of the links.

All cables should be carefully checked for “shorts” and “opens.”

If cables are O.K. it may be necessary to use a spectrum analyzer to examine the signal environment in which the BDA is operating. The existence of strong analog signals within the frequency bands can cause problems particularly on the downlink. In some cases additional filtering might be required to reject these unwanted signals. There may be some cases where the interference from outside signals is so great that they can not be filtered or otherwise reduced or eliminated without expensive and possibly prohibitive measures. In these cases it may not be practical to use the BDA for providing coverage at these sites.