

**FCC PART 24 TYPE APPROVAL
EUT USER MANUAL
FOR
CELLULAR SPECIALTIES, INC.**

670 N. Commercial St.
Manchester NH 03101

FCC ID: NVRCSI110-02

February 4, 2000

This Report Concerns: <input checked="" type="checkbox"/> Original Report	Equipment Type: Amplifier
Test Engineer: John Chan	
Test Date: January 24, 2000	
Reviewed By: John Y. Chan – Engineering Manager	
Prepared By: Bay Area Compliance Laboratory Corporation 230 Commercial Street, Suite 2 Sunnyvale, CA 94086 (408) 732-9162	

Note: This report may not be duplicated without prior written consent of Bay Area Compliance Laboratory Corporation. This report **must not** be used by the client to claim product endorsement by NVLAP or any agency of the U.S. Government.

TABLE OF CONTENTS

1 - GENERAL INFORMATION..... 3

- 1.1 PRODUCT DESCRIPTION FOR EQUIPMENT UNDER TEST (EUT)..... 3
- 1.2 OBJECTIVE 3
- 1.3 RELATED SUBMITTAL(S)/GRANT(S) 3
- 1.4 TEST METHODOLOGY..... 3
- 1.5 TEST FACILITY 4
- 1.6 TEST EQUIPMENT LIST 4
- 1.7 EQUIPMENT UNDER TEST (EUT)..... 5
- 1.8 SUPPORT EQUIPMENT 5
- 1.9 EUT CONFIGURATION DETAILS AND LIST 5
- 1.10 EXTERNAL I/O CABLING..... 5

2 - SYSTEM TEST CONFIGURATION..... 6

- 2.1 JUSTIFICATION 6
- 2.2 BLOCK DIAGRAM 6
- 2.3 TEST SETUP BLOCK DIAGRAM 7
- 2.4 EQUIPMENT MODIFICATIONS 8

APPENDIX A – AGENCY AUTHORIZATION LETTER..... 9

APPENDIX B – EUT USER MANUAL 11

1 - GENERAL INFORMATION

1.1 Product Description for Equipment Under Test (EUT)

The *Cellular Specialties, Inc.*, FCC ID *NVRCSE1110-02 (AMPLIFIER)* or the "EUT" as referred to in this report is a device using in enclosed structures where sufficient signal from local cell sites to operate cell phones was unavailable within the building. The device is connected to an external antenna, usually on the roof, and to one or more internal antennas placed strategically throughout the area where phone service is desired. The EUT measures 4.0" L x 3.5" W x 1.0" H.

1.2 Objective

This type approval report is prepared on behalf of *Cellular Specialties, Inc.* in accordance with Part 2, Subpart J, Part 15, Subparts A and B, and Part 24 Subpart E, of the Federal Communication Commissions rules.

The objective of the manufacturer is to demonstrate compliance with FCC rules for output power, 20 dB bandwidth, occupied bandwidth, spurious emission at antenna terminal, two-tone test, conducted and radiated margin.

1.3 Related Submittal(s)/Grant(s)

No Related Submittals

1.4 Test Methodology

All measurements contained in this report were conducted with ANSI C63.4 –1992, American National Standard for Methods of Measurement of Radio-Noise Emissions from Low-Voltage Electrical and Electronic Equipment in the range of 9 kHz to 40 GHz. All radiated and conducted emissions measurement was performed at Bay Area Compliance Laboratory, Corp. The radiated testing was performed at an antenna-to-EUT distance of 3 meters.

1.5 Test Facility

The Open Area Test site used by Bay Area Compliance Laboratory Corporation to collect radiated and conducted emission measurement data is located in the back parking lot of the building at 230 Commercial Street, Suite 2, Sunnyvale, California, USA.

Test sites at Bay Area Compliance Laboratory Corporation has been fully described in reports submitted to the Federal Communication Commission (FCC) and Voluntary Control Council for Interference (VCCI). The details of these reports has been found to be in compliance with the requirements of Section 2.948 of the FCC Rules on February 11 and December 10, 1997 and Article 8 of the VCCI regulations on December 25, 1997. The facility also complies with the radiated and AC line conducted test site criteria set forth in ANSI C63.4-1992.

The Federal Communications Commission and Voluntary Control Council for Interference has the reports on file and is listed under FCC file 31040/SIT 1300F2 and VCCI Registration No.: C-674 and R-657. The test sites has been approved by the FCC and VCCI for public use and is listed in the FCC Public Access Link (PAL) database.

Additionally, Bay Area Compliance Laboratory Corporation is a National Institute of Standards and Technology (NIST) accredited laboratory, under the National Voluntary Laboratory Accredited Program (NVLAP). The scope of the accreditation covers the FCC Method - 47 CFR Part 15 - Digital Devices, IEC/CISPR 22: 1993, and AS/NZS 3548: Electromagnetic Interference - Limits and Methods of Measurement of Information Technology Equipment test methods under NVLAP Lab Code 200167.

1.6 Test Equipment List

Manufacturer	Description	Model	Serial Number	Cal. Due Data
HP	Spectrum Analyzer	8566B	2610A02165	12/6/00
HP	Spectrum Analyzer	8593B	2919A00242	12/20/00
HP	Amplifier	8349B	2644A02662	12/20/00
HP	Quasi-Peak Adapter	85650A	917059	12/6/00
HP	Amplifier	8447E	1937A01046	12/6/00
A.H. System	Horn Antenna	SAS0200/571	261	12/27/00
Com-Power	Log Periodic Antenna	AL-100	16005	11/2/00
Com-Power	Biconical Antenna	AB-100	14012	11/2/00
Solar Electronics	LISN	8012-50-R-24-BNC	968447	12/28/00
Com-Power	LISN	LI-200	12208	12/20/00
Com-Power	LISN	LI-200	12005	12/20/00
BACL	Data Entry Software	DES1	0001	12/20/00
Rohde & Schwarz	Signal Generator	SMIQ03B	1125.5555.03	7/10/2002
Rohde & Schwarz	I/Q Modulation Generator	AMIQ	1110.2003.02	8/10/2002

1.7 Equipment Under Test (EUT)

Manufacturer	Description	Model	Serial Number	FCC ID
Cellular Specialties, Inc.	Amplifier	110 PCS	None	NVRCSI110-02

1.8 Support Equipment

Manufacturer	Description	Model	Serial Number	FCC ID
Rohde & Schwarz	Signal Generator	SMIQ03B	1125.5555.03	Doc
Rohde & Schwarz	I/Q Modulation Generator	AMIQ	1110.2003.02	Doc

1.9 EUT Configuration Details and List

NOT APPLICABLE

1.10 External I/O Cabling

Cable Description	Length (M)	Port/From	To
Shielded BNC Cable	2.0	Rohde & Schwarz	EUT

2 - SYSTEM TEST CONFIGURATION

2.1 Justification

The EUT was configured for testing in a typical fashion (as normally used in a typical application).

The final qualification test was performed with the EUT operating at normal mode.

2.2 Block Diagram

Appendix A contains a copy of the EUT's block diagram as reference.

2.3 Test Setup Block Diagram

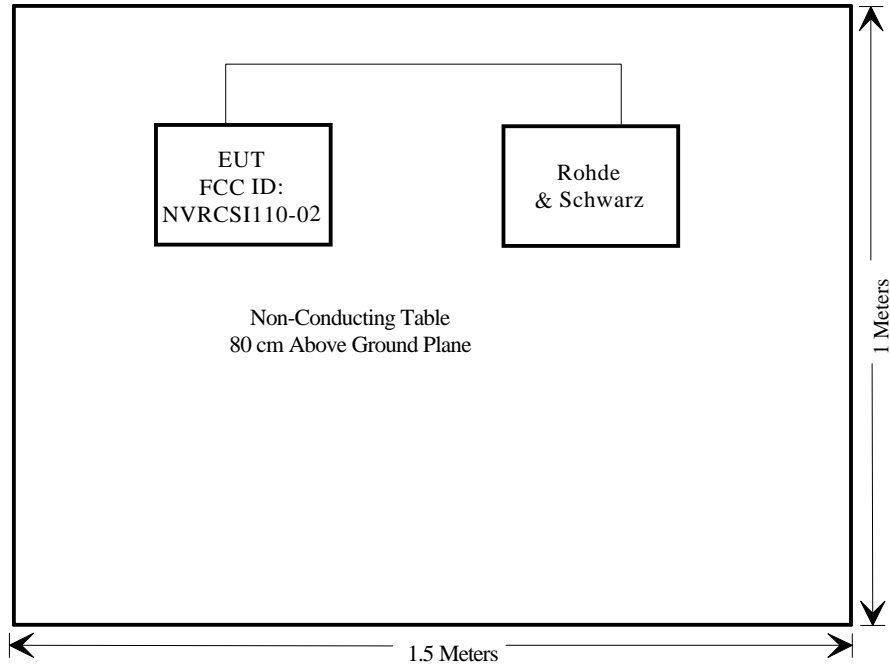

2.4 Equipment Modifications

No modifications were necessary for the EUT to comply.

Appendix A – AGENCY AUTHORIZATION LETTER



Cellular Specialties 670 N. Commercial St. Manchester NH 03101
Ph: 603-626-6677 Fax: 603-626-6042

17 January 2000

FEDERAL COMMUNICATIONS COMMISSIONS
Authorization and Evaluation Division
7435 Oakland Mills Road
Columbia, MD 21046

Subject: Agent Authorization

To whom it may concern:

Cellular Specialties, Inc. hereby authorizes Bay Area Compliance Laboratory Corporation to act on its behalf in all matters relating to application for equipment authorization, including the signing of all documents relating to these matters. All acts carried out by Bay Area Compliance Laboratory Corporation on our behalf shall have the same effect as our own action.

Sincerely,

A handwritten signature in cursive script, appearing to read "Fred Goodrich".

Fred Goodrich, President
Cellular Specialties, Inc.

Appendix B – EUT USER MANUAL

Cellular Specialties, Inc.

Model 110_{pcs} Miniature In-Building Amplifier

Operation and Users Manual

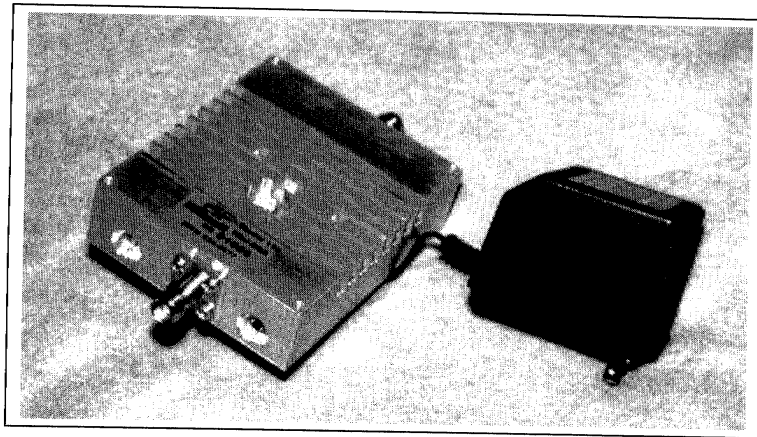

Table of Contents

- 1. Product Description**
 - Background
 - Functional Description
 - Circuit Description
 - Functional Block Diagram
 - Outline Drawing
- 2. General Specifications**
- 3. Inspection and Installation**
 - Inspection of Contents
 - Package Contents
 - Installation
 - Safety

1. Product Description

Background

The performance of a cell phone can be easily degraded when in enclosed structures where signals from a local cell site are not sufficient for reliable phone operation. The Model 110_{pcs} Miniature In-Building Amplifier (Mini-IBA) was developed by Cellular Specialties, Inc. (CSI) to enhance cellular performance within these enclosed structures. Specifically, the Mini-IBA is designed to cover small areas such as home offices, small workshops, etc.

Functional Description

The Mini-IBA boosts the cellular performance by providing amplification of both transmit and receive signals. The unit receives the portable phone's signal through an interior antenna, amplifies it and then sends it to an outside antenna. This signal is referred to as the "Uplink". The Mini-IBA also receives signals from the Cell Site base station through the outside antenna. This signal is amplified and re-radiated to the portable phone and is referred to as the "Downlink". It is necessary that sufficient signal be available at the external antenna.

The external antenna is usually a directional type such as a "Yagi", however an Omni-directional antenna may be used when the structure is located in close proximity to one or more cell sites. Internal antennas are usually Omni-directional although other types, such as low profile wall or ceiling mount, may be used for special installations.

As shown in Figure 1, there are three stages of gain in the Downlink and 2 stages in the Uplink for a maximum gain of 40 dB in each link. The maximum linear output power for the Uplink is 100 milli-Watts and 30 milli-Watts for the Downlink.

An LED indicator on the unit shows the application of power.

Circuit Description

Uplink

The uplink rf circuit consists of two stages of gain. Each gain stage is a monolithic integrated circuit (mmic) mounted to a printed circuit board (PCB). The signal received by the inside antenna is directed to the 1st mmic stage by a frequency diplexer, which separates the uplink frequency (1850-1865 MHz) from the downlink frequency (1930-1945 MHz). This signal is amplified by both mmic stages and directed to an identical diplexer at the output of the 2nd stage. Both stages are biased for linear operation. The overall gain from the inside antenna terminal to the outside antenna terminal is a maximum 40 dB. Each diplexer provides 60 dB of rejection between the uplink amplifier chain and the downlink.

Downlink

The downlink circuit is similar in operation to the uplink, except that it uses three stages of mmic amplification. The major differences are the downlink frequency (1930-1945 MHz) and signal flow in the opposite direction.

Power Supply

All the mmic amplification stages, in both the uplink and downlink, operate from a single supply voltage of +5 Vdc. A "Wall" power supply and dc-dc converter is used to provide the 5 volts from an input of 110 Vac. All internal dc circuits are filtered and de-coupled from the rf circuits. The overall current at 5 Vdc is less than 1.0 Amp.

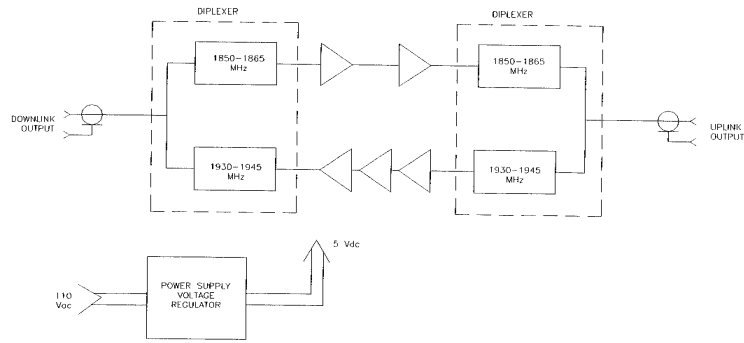

FIGURE 1 Functional Block Diagram

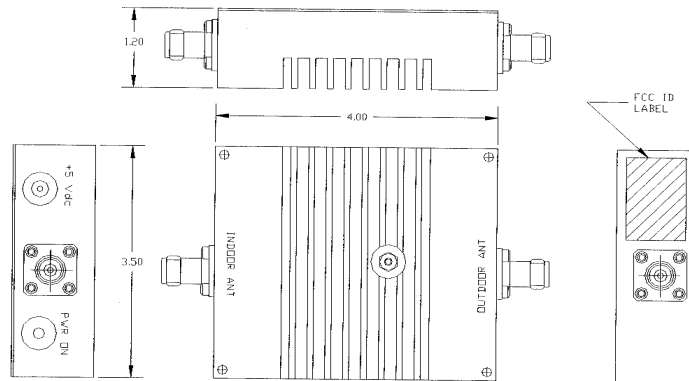

FIGURE 2 Outline Drawing

2. General Specifications

All specifications stated as typical unless otherwise noted. Cellular Specialties, Inc. reserves the right to change these specifications at any time without prior notice.

	Uplink	Downlink
Frequency Band	1850-1865 MHz	1930-1945 MHz
Linear Gain (dB)	35 min / 40 max	35 min / 40 max
Typical Power Out (max)		
1 dB Compression	+23 dBm	+17 dBm
Linear	+20 dBm	+15 dBm
Noise Figure	6 dB	6 dB
3 rd Order Intercept	+38 dBm	+27 dBm
Propagation Delay	<1 microsecond	<1 microsecond
VSWR	<2:1	<2:1
Passband Ripple (max)	2 dB pk-pk	2 dB pk-pk
Connectors	Mini-UHF	
Power Requirements	+5 Vdc, 1.0 A	
Dimensions	3.5"x4.0"x1.2"	
Weight	1 lbs.	
Indicator LED	"Power-On"	

3. Inspection and Installation

Inspection

Inspect the equipment as soon as possible after purchase. If any part of the equipment has been damaged in transit, report the damage to the transportation company and also to the company where purchased.

Contents

The unit package contains the following:

Model 110_{pcs} Mini-IBA
Power Transformer, 110 volt to 5 volt – model number ()
User Manual

Optional Accessories

Accessories are available directly from Cellular Specialties, Inc. or any of CSI's distributors.

Exterior High Gain Antenna – model number ()
Interior Omni Antenna – model number ()

Installation

Note:

The Installer should refer to the ***Safety Precautions***, in the following section, for proper antenna selection and installation

The installation of the Mini-IBA is relatively simple. If possible, measurements of the Received Signal Strength Indicator (RSSI) should be recorded as close as possible to the proposed exterior antenna location. Optimum performance will be obtained with RSSI readings greater than -85 dBm.

With the exact location of the exterior antenna and the coordinates of the cell sites closest to the building in which the unit is being installed, the distance and bearings to each of the local cells can be determined. The first choice would be the closest site unless there is blockage in the form of buildings or terrain. If blockage exists, an alternate site may be available.

If coordinates are not available, measure the RSSI at the external antenna output by connecting a phone to the external antenna and slowly rotating the antenna until a maximum reading is obtained.

The Mini-IBA and interior antenna should be centrally located, keeping coaxial cable runs to a minimum. A maximum length of 100 feet of low loss cable is recommended. The actual coax used should be RG-8 type with a flame retardant rating as a minimum. If the coax is run through an area where heating and/or cooling air is channeled, a plenum rated coax should be used. When mounting the amplifier, take care to avoid areas of high heat or extreme cold. In general, do not place the unit on or near the top of high ceilings, by heaters or in cold storage areas.

During installation, care must be taken to provide the maximum isolation between interior and exterior antennas. This isolation should be in the order of 70 dB to prevent any re-generative feedback in the system. Feedback of this nature may cause the amplifier to emit a continuous signal at maximum amplitude and could, in some cases, interfere with the normal operation of the cell site.

There are no installation or user adjustments or tuning on this unit.

*Safety Precautions***CAUTION**

For **INDOOR** use, an Omni-Directional Antenna with a maximum gain of 8dBi is authorized for use with this unit.

Inside antennas must be positioned to observe minimum separation of 20 cm. (~ 8 in.) from all users and bystanders. For the protection of personnel working in the vicinity of inside (downlink) antennas, the following guidelines for minimum distances between the human body and the antenna must be observed.

The installation of an **INDOOR** antenna must be such that, under normal conditions, all personnel cannot come within 20 cm. (~ 8.0 in.) from any inside antenna. Exceeding this minimum separation will ensure that the employee or bystander does not receive RF-exposure beyond the Maximum Permissible Exposure according to section 1.1310 i.e. limits for General Population/Uncontrolled Exposure.



For **OUTDOOR** use, a Directional Antenna up to a maximum gain of 13dBi is authorized for use with this unit.

The Outside antenna must be positioned to observe minimum separation of 20 cm. (~ 8 in.) from all users and bystanders. For the protection of personnel working in the vicinity of outside (uplink) antennas, the following guidelines for minimum distances between the human body and the antenna must be observed.

The installation of an **OUTDOOR** antenna must be such that, under normal conditions, all personnel cannot come within 20 cm. (~ 8 in.) from the outside antenna. In all installations, the antenna should never be mounted such that the main beam is directed toward an area where workers or bystanders may be present. Exceeding this minimum separation will ensure that the worker or bystander does not receive RF-exposure beyond the Maximum Permissible Exposure according to section 1.1310 i.e. limits for General Population/Uncontrolled Exposure.

MODEL 110_{pcs} Mini-BDA Circuit Description

Uplink

The uplink RF circuit consists of two stages of gain. Each gain stage is a monolithic integrated circuit (mmic) mounted to a printed circuit board (PCB). The signal received by the inside antenna is directed to the 1st mmic stage by a frequency diplexer, which separates the uplink frequency (1850-1865 MHz) from the downlink frequency (1930-1945 MHz). This signal is amplified by both mmic stages and directed to an identical diplexer at the output of the 2nd stage. Both stages are biased for linear operation. The overall gain from the inside antenna terminal to the outside antenna terminal is a maximum 40 dB. Each diplexer provides 60 dB of rejection between the uplink amplifier chain and the downlink.

Downlink

The downlink circuit is similar in operation to the uplink, except that it uses three stages of mmic amplification. The major differences are the downlink frequency (1930-1945 MHz) and signal flow in the opposite direction.

Power Supply

All the mmic amplification stages, in both the uplink and downlink, operate from a single supply voltage of +5 Vdc. A "Wall" power supply and dc-dc converter is used to provide the 5 volts from an input of 110 Vac. All internal dc circuits are filtered and de-coupled from the RF circuits. The overall current at 5 Vdc is less than 1.0 Amp.

**Evaluation of the CSI Model 110_{pcs} BDA
For
Compliance with FCC Guidelines
For Human Exposure to Radio Frequency
Electromagnetic Fields**

14 December 1999

General

The CSI Model 110_{pcs} Bi-directional amplifier is considered to be a “mobile” device operating in the Personal Communications Service authorized under part 24. As such, the equipment is required to be evaluated for RF exposure if operated above 1.5 GHz with an effective radiated power (ERP) of 3.0 watts or more, as defined in 2.1091 of FCC rules.

Downlink

For the downlink portion of the Model 110_{pcs} BDA, the maximum rated output power is +17dBm (50 mW). As stated in the Model 110_{pcs} Manual, the maximum authorized antenna gain is 8 dBi, corresponding to a Co-Linear Omni-Directional antenna. Neglecting cable losses, the worst-case EIRP will be 0.32 watts or an ERP of 0.19 watts, (ERP=EIRP/1.64). This is well below the 3.0 watts ERP limit and therefore excludes the downlink from routine evaluation. The Cautions in the Model 110_{pcs} manual clearly define the antenna selection and installation criteria in order to maintain a minimum 20-centimeter separation.

Uplink

For the uplink portion of the Model 110_{pcs} BDA, the maximum rated output power is +23dBm (200 mW). As stated in the Model 110_{pcs} Manual, the maximum authorized antenna gain is 13 dBi, corresponding to a Yagi Directional antenna. Neglecting cable losses, the worst-case EIRP will be 3.99 watts or an ERP of 2.43 watts, (ERP=EIRP/1.64). This is below the 3.0 watts ERP limit and therefore excludes the uplink from routine evaluation. The Cautions in the Model 110_{pcs} manual clearly define the antenna selection and installation criteria in order to maintain a minimum 20-centimeter separation.

Conclusion

Because of the low output power and antenna gains, both the uplink and downlink will satisfy the requirements for RF Exposure per FCC rules 1.1311.

MODEL 110 mini-BDA POWER PER CHANNEL

Channels	UpLink dBm	DownLink dBm
1	20.0	15
2	16.0	11.0
3	13.7	8.7
4	12.0	7.0
5	10.7	5.7
6	9.7	4.7
7	8.8	3.8
8	8.0	3.0
9	7.3	2.3
10	6.7	1.7
11	6.2	1.2
12	5.7	0.7
13	5.2	0.2
14	4.8	-0.2
15	4.4	-0.6
16	4.0	-1.0
17	3.6	-1.4
18	3.3	-1.7
19	3.0	-2.0
20	2.7	-2.3

Power per Channel-PCS-Rev A.xls

1/3/00

