



# VHF 1/4W Public Safety Signal Booster

## Users Guide

# PRODUCT MANUAL

## DISCLAIMER

All information and statements contained herein are accurate to the best of Westell Technologies knowledge. Westell makes no warranty with respect there to, including without limitation any results that may be obtained from the products described herein or the infringement by such products of any property rights of any persons. Use or application of such information or statements is at the users' sole risk, without any liability on the part of Westell. Nothing herein shall be construed as license or recommendation for use, which infringes upon any propriety rights of any person. Product material and specifications are subject to change without notice. Westell standard terms of sale and the specific terms of any particular sale apply.

# Table of Contents

<b>PREFACE.....</b>	<b>7</b>
Purpose.....	7
Scope.....	7
Audience.....	7
Document Organization .....	8
References.....	9
Document Conventions.....	9
Safety Notices .....	10
Technical Support.....	10
Acronyms and Abbreviations .....	10
Copyright and Trademark Acknowledgements .....	10
<b>1 GENERAL INFORMATION .....</b>	<b>11</b>
1.1 Document Purpose and Intended Users .....	11
1.2 Application.....	11
1.2.1 Product Registration Information .....	11
1.3 Safety Guidelines.....	12
1.3.1 Important Safety Information .....	13
1.4 FCC Part 90 Signal Boosters .....	13
1.5 FCC Contact Information .....	15
<b>2 PRODUCT OVERVIEW .....</b>	<b>16</b>
2.1 Product Information.....	16
2.2 Product Features .....	17

2.3 Included Accessories.....	17
2.4 Optional Accessories .....	19
<b>3 PRODUCT SPECIFICATION .....</b>	<b>18</b>
3.1 RF Specifications .....	18
3.2 Power Specification .....	Error! Bookmark not defined.18
3.3 Mechanical Specification .....	Error! Bookmark not defined.18
<b>4 PRODUCT APPEARANCE.....</b>	<b>ERROR! BOOKMARK NOT DEFINED.</b>
4.1 External Configuration .....	Error! Bookmark not defined.
<b>5 INSTALLATION GUIDELINES.....</b>	<b>ERROR! BOOKMARK NOT DEFINED.22</b>
5.1 Important Installation Guidelines .....	Error! Bookmark not defined.22
5.2 Donor Antenna Installation Guidelines .....	Error! Bookmark not defined.23
5.3 Indoor Antenna Installation Guidelines.....	Error! Bookmark not defined.23
5.4 Mounting the Signal Booster .....	Error! Bookmark not defined.24
<b>6 CONNECTING THE SIGNAL BOOSTER.....</b>	<b>ERROR! BOOKMARK NOT DEFINED.36</b>
6.1 Connecting Step-By-Step.....	Error! Bookmark not defined.36
<b>7.0 SYSTEM OPERATION .....</b>	<b>38</b>
<b>8.0 STATUS INDICATORS.....</b>	<b>43</b>
<b>9.0 SOFTWARE .....</b>	<b>45</b>
9.1 Introduction.....	Error! Bookmark not defined.45
9.2 Local Software.....	Error! Bookmark not defined.45
<b>10.0 REMOTE WEB SERVER OPTION .....</b>	<b>51</b>

10.1 Introduction.....	<b>Error!</b>
<b>Bookmark not defined.51</b>	
10.2 Webpage Description.....	<b>Error!</b>
<b>Bookmark not defined.52</b>	
<b>11.0 RF PARAMETER DESCRIPTIONS .....</b>	<b>62</b>
<b>12.0 SPECTRUM ANALYZER .....</b>	<b>70</b>
<b>13.0 SNMP AGENT .....</b>	<b>73</b>
<b>14.0 SNMP TRAPS.....</b>	<b>83</b>
<b>APPENDIX A IMPORTANT PRODUCT INFORMATION.....</b>	<b>94</b>
A.1 Registration Number.....	94
A.2 UL.....	94
<b>APPENDIX B ACRONYMS AND ABBREVIATIONS.....</b>	<b>95</b>

**INTENTIONALLY BLANK**

## Preface

This Preface includes the following:

- Purpose
- Scope
- Audience
- Document Organization
- References
- Document Conventions
- Safety Notices
- Technical Support
- Acronyms and Abbreviations
- Copyright and Trademark Acknowledgements

### Purpose

This manual contains information and procedures for the operation of the Westell VHF Public Safety Signal Booster.

Changes that occur after the publishing date may be incorporated by a complete manual revision or as additions.

### Scope

Reference this manual when there is a need to add enhanced signal capability to a new or existing system, to monitor a system, make maintenance adjustments, or address alarms.

### Audience

This manual is intended for installers and users who are familiar with similar types of equipment.

## Document Organization

This manual includes the following chapters:

- **Chapter 1: General Information** – Outlines the document purpose and intended users, application, product registration, safety guidelines, disclaimer and FCC Part 90, FCC Warning Labels.
- **Chapter 2: Product Overview** – Provides product information, describes product features and lists accessories.
- **Chapter 3: Product Specification** – Provides tables containing RF, power, mechanical and environmental specifications. Also provides information about GUI items, alarm status and alarm relay.
- **Chapter 4: Product Appearance** – Provides physical specifications, photographs and information about the external and internal Signal Booster configuration.
- **Chapter 5: Installation Guidelines** – Lists guidelines for installing the Signal Booster and antennas.
- **Chapter 6: Connecting the Signal Booster** – Provides guidelines on connecting the signal booster to power, antennas, etc.
- **Chapter 7: System Operation** – Describes product operation, including how to open the communication port and describes the functions in the Status and Control pages.
- **Chapter 8: Status Indicators** – Outlines the LEDs status lights on the signal booster.
- **Chapter 9: Software Installation** – Outlines the steps required to install the software.
- **Chapter 10: Remote Web Server Option** – Outlines the steps required to connect remotely.
- **Chapter 11: RF Parameters** – Outlines the signal booster's RF parameters in the GUI.
- **Chapter 12: Spectrum Analyzer** – Outlines the steps required to use the imbedded spectrum analyzer.
- **Chapter 13: SNMP Agent** – Outlines the steps required to use the SNMP Agent.
- **Chapter 14: SNMP Traps** – Outlines the traps for the SNMP Agent.
- **Appendix A: Important Product Information** – Provides the product registration number and internal power supply information.
- **Appendix B: Acronyms and Abbreviations** – A table of acronyms and abbreviations and definitions for each.



## References

- FCC Part 90

## Document Conventions

Table P-1 lists the conventions used throughout this document.

Table P-1: Document Conventions

Convention	Description
<b>DANGER!</b>	Description of an imminent hazard that, if not avoided, may result in severe personal injury or death. Before you work on equipment, be aware of the hazards involved with electrical and RF circuitry and be familiar with standard practices for preventing accidents.
<b>WARNING!</b>	Description of an imminent hazard that, if not avoided, may result in personal injury or serious equipment damage.
<b>CAUTION</b>	Description of a conditions or practice that could cause damage to equipment or property. Communicates information that is crucial to preventing loss of data or damage to hardware or software, and actions that could result in equipment failure.
<b>IMPORTANT</b>	Additional important information that the user must be aware of, but is not related to a hazard.
<b>NOTE</b>	Additional information that is beneficial for the user to know, but is not related to a hazard.
<b>Bold</b>	Bold text indicates an action or provides emphasis.
<b>Click</b>	Instructs the user to press the primary (typically left) mouse button while the pointer is over the specified location.
<b>Right-click</b>	Instructs the user to press the secondary (typically right) mouse button while the pointer is over the specified location.
<b>Double-click</b>	Instructs the user to press the primary (typically left) mouse button twice, rapidly, while the pointer is over the specified location.
<b>Select</b>	Instructs the user to perform a selection on the screen by clicking an active object.
<b>Enter</b>	Instructs the user to type text using the keyboard.

>	Indicates a level in a menu. For example, <b>Start&gt;Programs</b> prompts the user to click on Start, then locate and click Programs under the Start menu.
---	---

## Safety Notices

This general safety information applies to both operating and service personnel. Specific warnings and cautions are located in other parts of this manual where they apply and may not appear in this summary. Failure to comply with these precautions or specific warnings elsewhere in the manual violates the safety standards of design, manufacture, and intended use of equipment.

Westell assumes no liability for the customer's or user's failure to comply with these requirements:

- **Explosive atmospheres** - To avoid explosion or fire, do not operate this product in the presence of flammable gases or fumes.
- **Lightning danger** - Do not install or make adjustments to this unit during an electrical storm.

## WARNING!

Changes and Modifications not expressly approved by Westell can void your authority to operate this equipment under Federal Communications Commission's rules.

## Technical Support

If you suspect a malfunction with this product or have a technical question, call your dealer or the Westell Support Line at: (603) 626-6677, Toll Free (USA) 1-877-844-4274, press option 2, and then option 1. Westell Support can also be reached via email at [IBWsupport@westell.com](mailto:IBWsupport@westell.com).

## Acronyms and Abbreviations

Refer to Appendix B for definitions of the acronyms and abbreviations used in this manual.

## Copyright and Trademark Acknowledgements

The following products are referred to in this manual:

-  **WESTELL** is a registered trademark of Westell Technologies, Inc.

## 1 General Information

### 1.1 Document Purpose and Intended Users

The purpose of this document is to provide a step-by-step procedure to help experienced technicians or engineers install and commission an in-building Passive Wireless Distributed Antenna System (DAS) using Westell's VHF Public Safety Signal Booster. Follow the instructions in this guide to minimize risks associated with modifying a live system and preclude service interruptions. This document assumes the technician or engineer understands the basic principles and functionality involved with an RF Signal Booster and in-building wireless systems. This guide has been written to address the practical concerns of the installer.

### 1.2 Application

Use this guide whenever there is a need to add enhanced signal capability to an existing system or when a Signal Booster is included in a new installation.

#### 1.2.1 Product Registration Information

The serial number is located on the label on the panel near the power connectors. Record this number in Figure 1-1. Retain this manual, along with proof of purchase, to serve as a permanent record of your purchase.

MODEL NUMBER	SERIAL NUMBER	PURCHASE DATE
<input type="text"/>	<input type="text"/>	<input type="text"/>
POINT OF SALE COMPANY		
<input type="text"/>		

Figure 1-1: Product Registration

### 1.3 Safety Guidelines

The general safety information in this guideline applies to both operations and service personnel. Specific warnings and cautions are located in the applicable manual sections, but may not appear in this summary. Failure to comply with these precautions or specific warnings elsewhere in the manual violates safety standards of design, manufacture, and intended use of equipment. Westell assumes no liability for the customer's failure to comply with these requirements:

**Grounding:** This Signal Booster is designed to operate at 110VAC or +24/-48VDC and must always be operated with the ground wire properly connected.

**Explosive atmospheres:** To avoid explosion or fire, do not operate this product in the presence of flammable gases or fumes.

**Lightning danger:** Do not install or adjust this unit during an electrical storm.

No user-serviceable parts are inside the unit. Hazardous voltages are present when the cover is removed. Opening the chassis will void your warranty. If you suspect a malfunction with this product, call your dealer or Westell's technical support line at 1.877.844.4274.

## CAUTION

Turn the Signal Booster power off when connecting or disconnecting cables.

### 1.3.1 Important Safety Information

Antennas used for the purpose of radiating signals indoors are limited to a maximum gain of 10 dBi. Each antenna must be positioned to observe minimum separation requirements from all users and bystanders.

The following guidelines must be used when considering separation distances:

- Indoor antennas must be placed so that under normal conditions, personnel cannot come within 55 cm of any inside antenna. Adhering to this minimum separation will ensure that the employee or bystander cannot exceed RF exposures beyond the maximum permissible limit as defined by FCC Regulations section 1.1310 Limits for general population/uncontrolled exposure.
- Outdoor antenna must be positioned so that under normal conditions, personnel cannot approach closer than 55 cm. A directional antenna having a maximum gain of 10 dBi is used, and precautions should be taken to prevent personnel from routinely passing through the main radiation beam at a distance closer than specified.

### 1.4 FCC Part 90 Signal Boosters

#### **WARNING!**

THIS IS A 90.219 CLASS B DEVICE

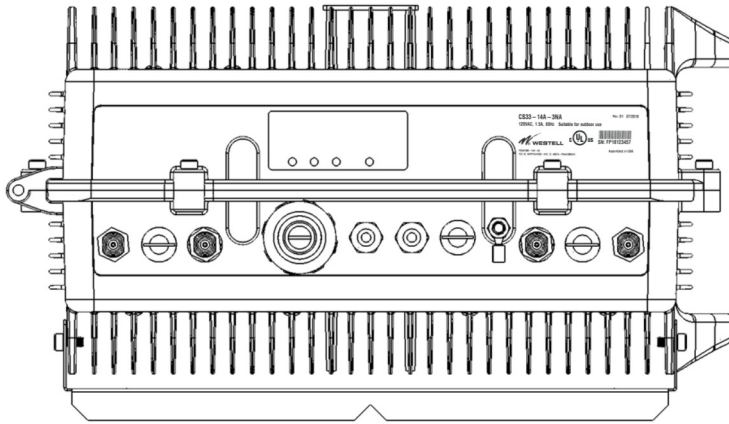
**This is not a consumer device.** It is designed for installation by FCC licensees and qualified installers. You must have an FCC license or express consent of an FCC Licensee to operate this device. You must register class B signal boosters (as defined in 47 CFR 90.219) online at [www.fcc.gov/signal-boosters/registration](http://www.fcc.gov/signal-boosters/registration). Unauthorized use may result in significant forfeiture penalties, including penalties in excess of \$100,000 for each continuing violation.

#### FCC Warning Label

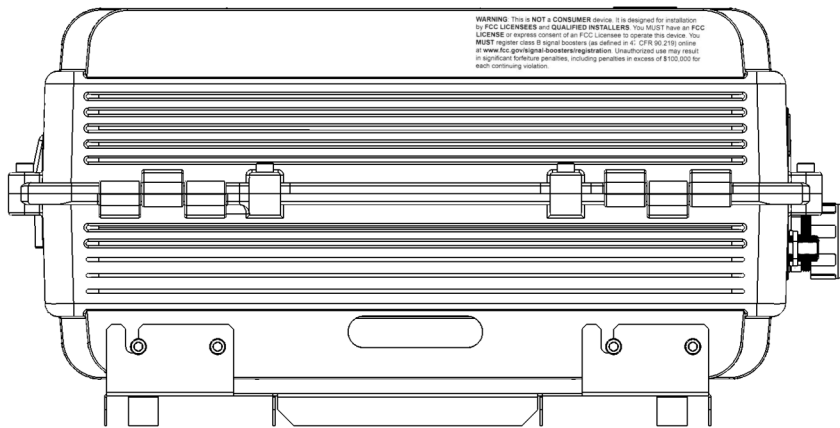
The following label will appear on the VHF Signal Booster in accordance with the FCC:

**WARNING** This is **NOT** a **CONSUMER** device. It is designed for installation by **FCC LICENSEES** and **QUALIFIED INSTALLERS**. You **MUST** have an **FCC LICENSE** or express consent of an FCC Licensee to operate this device. You **MUST** register Class B signal boosters (as defined in 47 CFR 90.219) online at [www.fcc.gov/signal-boosters/registration](http://www.fcc.gov/signal-boosters/registration). Unauthorized use may result in significant forfeiture penalties, including penalties in excess of \$100,000 for each continuing violation.

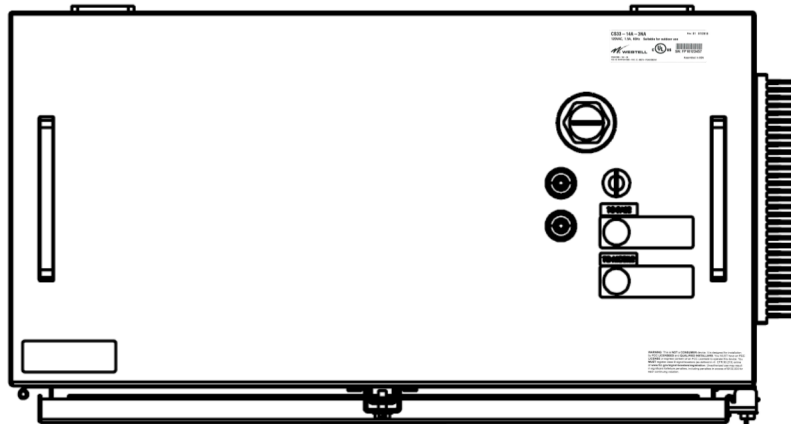
FCC Label Placement on the VHF Signal Booster:



Top View



Side View



Top View

## 1.5 FCC Contact Information:

Federal Communications Commission  
445 12th Street SW  
Washington, DC 20554

Phone: 1-888-225-5322

TTY: 1-888-835-5322

Fax: 1-866-418-0232

## IC Compliance

As per RSS-131 Issue 3:

- Nominal passband gain: 80dB
- Nominal bandwidth: 2MHz
- Rated mean output power: +24dBm
- Input and Output impedances: 50 ohms

The Manufacturer's rated output power of this equipment is for single carrier operation. For situations when multiple carrier signals are present the rating would have to be reduced by 3.5dB especially where the signal is re-radiated and can cause interference to adjacent band users. This power reduction is to be by means of input power or gain reduction and not by an attenuator at the output of the device.

RF exposure statement for ISSED: "This device complies with Health Canada's Safety Code. The installer of this radio equipment must ensure that the antenna is located or pointed such that it does not emit RF field in excess of Health Canada limits for the general population; consult safety code 6, obtainable from Health Canada's website at [www.hc-sc.gc.ca/rpb](http://www.hc-sc.gc.ca/rpb)"

The antenna/s used for this transmitter must be installed to provide a separation of at least 55 cm in DL and 55 cm in UL from all persons and must not be collocated or operating in conjunction with any other antenna or transmitter. Changes or modifications not expressly approved by the party responsible for compliance could void the user's authority to operate the equipment.

Selon RSS-131 Issue 3 :

- Gain de bande passante nominale : 80dB
- Band passante nominale: 2MHz
- Puissance nominale de sortie moyenne: +24dBm
- Entrée et sortie impédances: 50 ohms

Puissance de sortie nominale du fabricant de cet équipement est pour opération porteuse unique. Pour les situations lorsque plusieurs signaux porteurs figurent la notation devra être réduite de 3.5dB surtout où le signal est re-rayonné et peut causer des interférences aux utilisateurs de la bande adjacente. Cette réduction de puissance doit être au moyen de la réduction de puissance ou de gain d'entrée et non par un atténuateur à la sortie de l'appareil.

Déclaration d'exposition aux RF pour ISED : « Cet appareil est conforme avec le Code de sécurité de Santé Canada. Le programme d'installation de cet équipement radio doit s'assurer que l'antenne est située ou fait telle qu'elle n'émet pas de RF a déposé plus de limites de Santé Canada pour la population générale ; consulter le code de sécurité 6, disponible depuis le site Web de Santé Canada à [www.hc-sc.gc.ca/rpb](http://www.hc-sc.gc.ca/rpb) »

L'antenne/s utilisée pour ce transmetteur doit être installé pour fournir une séparation d'au moins 55 cm en DL et UL 55 cm de toute personne et ne doit pas être colocalisés ou fonctionner en conjonction avec toute autre antenne ou transmetteur. Changements ou modifications non expressément approuvées par la partie responsable de la conformité pourraient annuler autorisation votre d'utiliser l'équipement.

## 2 Product Overview

### 2.1 Product Information

The VHF Signal Booster was developed for use in enclosed structures where signals from local public safety towers to operate mobile units is poor or unavailable. Adequate signal strength must be available outside the structure as a prerequisite to achieving in-building coverage. The device is connected to an external antenna, normally located on a roof, and to one or more internal antennas placed strategically throughout the area where wireless service is desired.

The VHF Signal Booster Series is a Digital Signal Booster that operates in the 136 – 174 MHz frequency range.

The external antenna is typically directional, such as a Yagi or Panel antenna. Internal antennas are typically omnidirectional, although various other types may be used, depending on the coverage application. The Signal Booster amplifies both the uplink (mobile to base) and downlink (base to mobile) signals, thus facilitating communications to and from the intended wireless infrastructure. With a maximum total of 80 dB nominal gain on both the uplink and downlink, gain can be adjusted over a range from 52 dB to 80 dB in 1 dB steps.



Each band has a separate intermediate filtering. The intermediate filtering is done using FPGA based Digital Signal Processing that, among many, has the following features:

- High Selectivity vs Low Delay
- AGC per channel and per time slot
- Squelch per channel and per time slot
- Integrated Spectrum Analyzer

This Signal Booster is capable of handling 32 filters in uplink and 32 filters in downlink. The center frequency and BW of each one of the filters can be tuned via a software interface.

This Digital Signal Booster is intended to be used in P25Ph1, P25Ph2, TETRA, DMR, Mototrbo and Conventional radio systems.

This Digital Signal Booster has a heavy duty IP67/NEMA4X cabinet for outdoor usage, it is designed to be wall or pole mounted.

## 2.2 Product Features

- Digital Class A
- Channel Selective
- 24 dBm (1/4 Watt)
- Supports up to 32 Channels (Uplink and Downlink)
- NFPA 1221 & 72 (2016) compliant
- IP67/NEMA 4X enclosure
- Uplink and Downlink squelch, per channel
- UL Listed
- Independent power and gain control per channel
- 80 dB Gain
- Integrated spectrum analyzer
- Dry Contacts for fire panel connection
- Supports SNMP
- Web-Based GUI

## 2.3 Included Accessories

Table 2-1 contains the items that are shipped with the UHF Public Safety Signal Booster.











Table 2-1: Included Accessories

Quantity	Description
1	AC or DC Power Cord
1	Hex Key


## 2.4 Optional Accessories

A complete line of accessories is available from Westell. Check with your Westell distributor for any additional items needed. Some products that are suitable for most in-building needs are listed in Table 2-2.

Table 2-2: Optional Accessories

Donor Antenna			
CSI-AY/746-896/11	Yagi, 11 dB, Public Safety 700/800 (746-896 MHz)		
Clearlink-APD/698-940/-153/15/4310f	Panel Donor Antenna, Low-Band, 698-960, High Isolation		
Server/Coverage Antenna			
ClearLink-O/698-2.7K/N	CS03-011-429		
ClearLink-D/698-2.7K/N	CS03-012-389		
Hybird Coupler		4.3-10 Type Connector	N-Type Connector
3 dB	ClearLink-HC3/340-2.7K/N	ClearLink-HC3/340-2.7K/4310	
Power Tapper (Non-PIM Rated)		4.3-10 Type Connector	N-Type Connector
6 dB	ClearLink-PT6/340-2.7K/4310	ClearLink-PT6/340-2.7K/N	
7 dB	ClearLink-PT7/340-2.7K/4310	ClearLink-PT7/340-2.7K/N	
8 dB	ClearLink-PT8/340-2.7K/4310	ClearLink-PT8/340-2.7K/N	
10 dB	ClearLink-PT10/340-2.7K/4310	ClearLink-PT10/340-2.7K/N	
13 dB	ClearLink-PT13/340-2.7K/4310	ClearLink-PT13/340-2.7K/N	
15 dB	ClearLink-PT15/340-2.7K/4310	ClearLink-PT15/340-2.7K/N	
20 dB	ClearLink-PT20/340-2.7K/4310	ClearLink-PT20/340-2.7K/N	
30 dB	ClearLink-PT30/340-2.7K/4310	ClearLink-PT30/340-2.7K/N	
Directional Coupler (Non-PIM Rated)		4.3-10 Type Connector	N-Type Connector
5 dB	ClearLink-DC5/340-2.7K/4310	ClearLink-DC5/340-2.7K/N	
6 dB	ClearLink-DC6/340-2.7K/4310	ClearLink-DC6/340-2.7K/N	
10 dB	ClearLink-DC10/340-2.7K/4310	ClearLink-DC10/340-2.7K/N	
15 dB	ClearLink-DC15/340-2.7K/4310	ClearLink-DC15/340-2.7K/N	
20 dB	ClearLink-DC20/340-2.7K/4310	ClearLink-DC20/340-2.7K/N	
30 dB	ClearLink-DC30/340-2.7K/4310	ClearLink-DC30/340-2.7K/N	
Power Divider (Non-PIM Rated)		4.3-10 Type Connector	N-Type Connector
2:1	CLEARLINK-SPD2/340-2.7K/4310	ClearLink-SPD2/340-2.7K/N	
3:1	ClearLink-SPD3/340-2.7K/4310	ClearLink-SPD3/340-2.7K/N	
4:1	ClearLink-SPD4/340-2.7K/4310	ClearLink-SPD4/340-2.7K/N	
Adapter			
4.3-10 (M) to N (F)	CS48-132-633		
Battery Back-up			
12/24 Hour Battery Back-up	PS-BBU-01		

### 3 Product Specifications

#### 3.1 RF Specifications

<b>Frequency Range</b>	136-174 MHz
<b>Downlink Output Power</b>	24 dBm (1/4 Watt)
<b>Uplink Power</b>	24 dBm (1/4 Watt)
<b>Channels Supported</b>	Up to 32 Uplink and Downlink
<b>Gain</b>	80 dBm
<b>Attenuation Range</b>	52-80 dB, 1 dB increments
<b>Passband</b>	Channel Selective (90 KHz, 45 KHz, 30 KHz, 20 KHz, and 15 KHz BW)
<b>IMD</b>	<-13 dBm
<b>Noise Figure</b>	9.0 dB Max
<b>Delay</b>	90 KHz, 14µs 45 KHz, 23µs 30 KHz, 32µs 20 KHz, 45µs 15 KHz, 55µs
<b>Input Power (w/o Damage)</b>	0 dBm Uplink (Max) -20 dBm Downlink (Max)
<b>VSWR</b>	1.5:1 Max

#### 3.2 Electrical Specifications

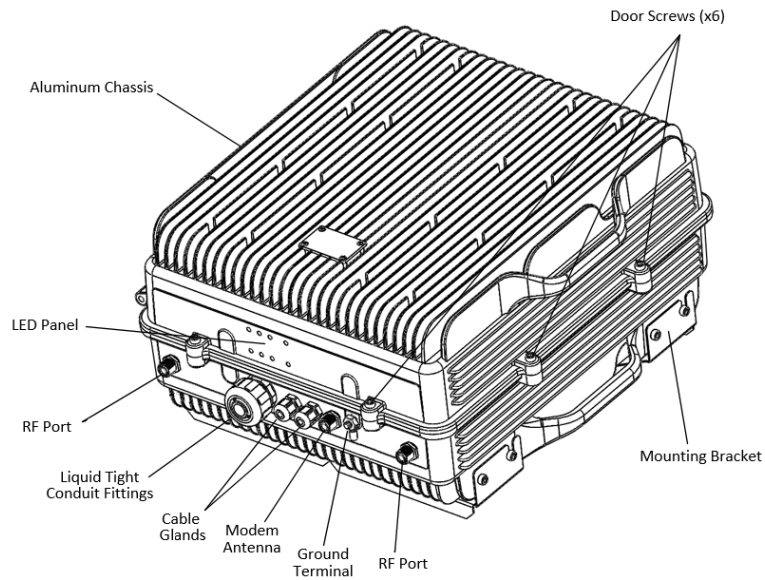
<b>Main Power Input Voltage</b>	110/220 VAC or DC (+24VDC to -48VDC)
<b>Power Consumption 1/4W Power Output</b>	<170W Max.

#### 3.3 Mechanical Specifications

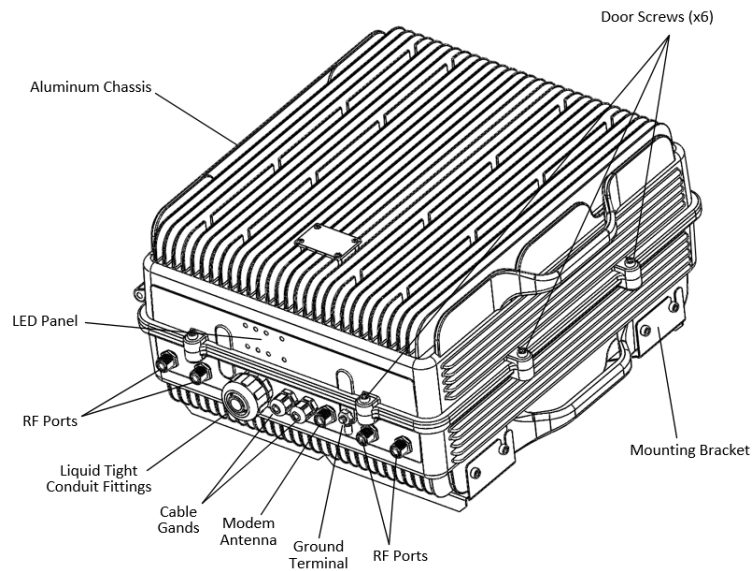
<b>Dimensions (LxWxD)</b>	20.2 x 18.2 x 9 inches (WST012)
<b>Weight</b>	55 lbs. (WST012)
<b>Cooling</b>	Passive
<b>Weatherproofing</b>	IP-67/NEMA 4X
<b>Connectors</b>	
<b>Antenna Ports</b>	N-Type Female
<b>User Interface</b>	USB
<b>Alarm Relay</b>	6-Wire Dry Contact Connector
<b>Operating Temperature</b>	-25 ° to +55 ° C
<b>Mounting</b>	Wall, Rack or Pole mounting

## 4 Product Appearance

### 4.1 External Configuration



**Figure:** VHF "2 Port" Duplexed Configuration



**Figure:** VHF "4 Port" Non-Duplexed Configuration

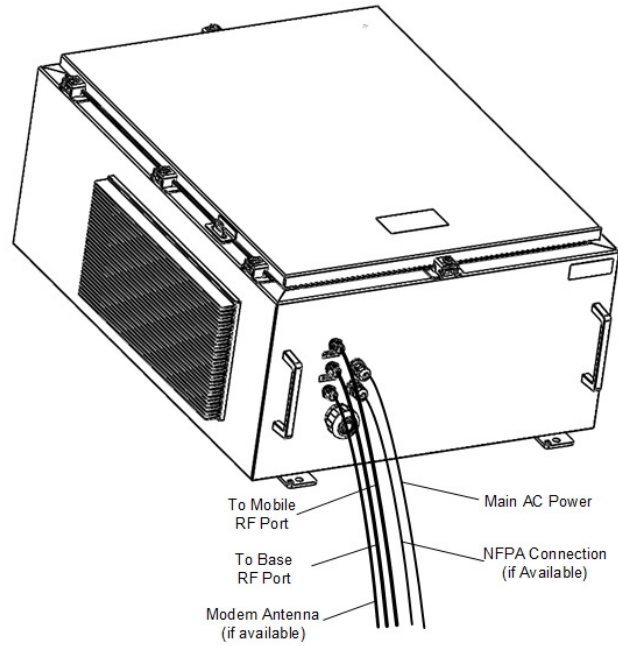


Figure: *WST021 Configuration*

### 5 Product Dimensions

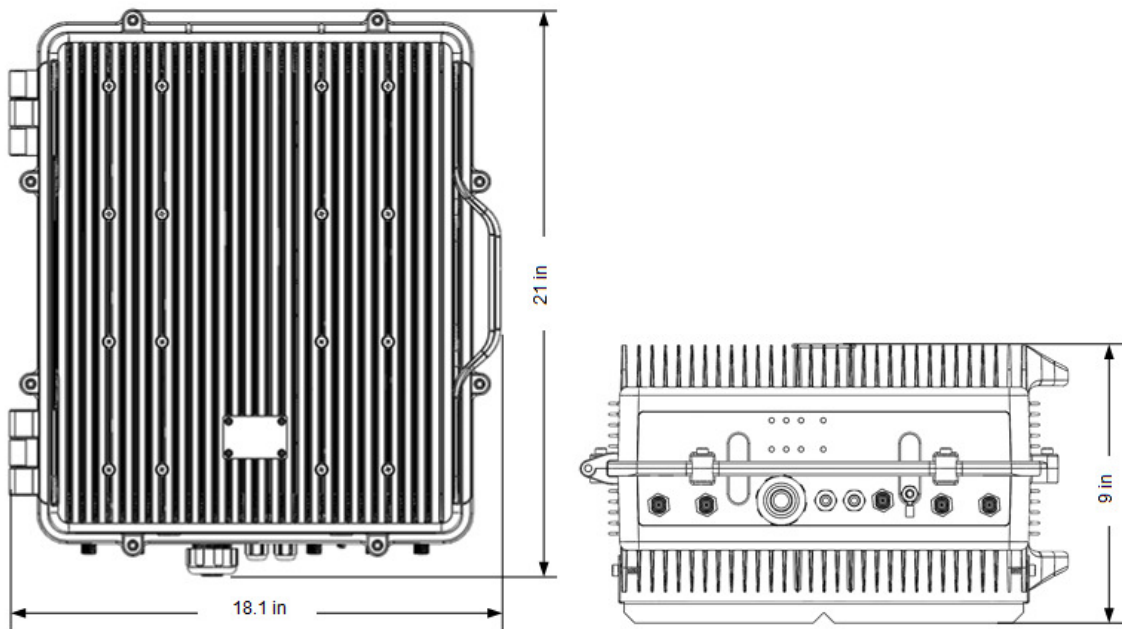


Figure: *WST012 dimensions*

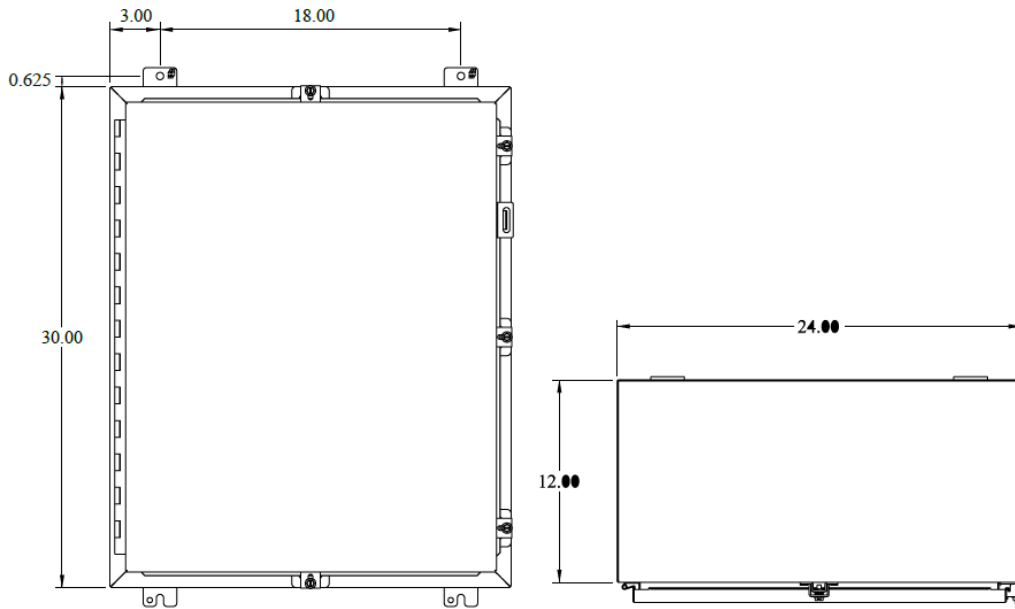


Figure: *WST021 dimensions*

## 5 Installation Guidelines

### 5.1 Important Installation Guidelines

- Westell Signal Boosters are designed for outdoor usage with a weather proof outdoor NEMA4 cabinet that can be mounted without any kind of shelter from rain, snow or hail.
- The Signal Booster must be installed in a vertical orientation (i.e. Connectors on the bottom of the unit).
- Inadequate isolation between the outside and inside antennas may cause regenerative feedback in the system.
  - This feedback can cause the amplifier to emit a continuous signal at maximum Amplitude, and, in some cases, interfere with normal operation of the donor site. Careful consideration of the layout and placement of the system is imperative to minimize this possibility and to minimize the amount of signal leaking from the Building.
- Do not disassemble the Signal Booster.

#### **Danger!**

- Refer to the 1.3 Safety Guidelines section for proper antenna selection and installation. To avoid serious injury, death and/or damage to the Signal Booster, do not install donor or server antennas near overhead power lines or high power components. Allow enough distance so that falling antennas would not come in contact with those components.
- Electric shock may occur if the Signal Booster is installed in close proximity to water.

#### **WARNING!**

- Amplifier or handset damage may occur if a handset is connected directly to the Signal Booster or to the coax that leads to the Signal Booster.
- The Signal Booster must be connected to ground for protection.
- We recommend that installers do not wear jewelry or metal accessories when installing this Signal Booster.
- Do not place cables or tools that may damage the Signal Booster in close proximity to it.
- Check the installation site for hazardous conditions such as water-covered floors or badly worn or damaged cables prior to installation.
- Lifespan and performance of the Signal Booster may be reduced if the unit is operating outside its nominal temperature range.
- However, to improve reliability, it is recommended to mount the Signal Booster on a site with shelter from direct exposure to sun, rain, snow and hailing.
- It is not recommended to install the Signal Booster under bad weather conditions, such as:
  - Intense rainfall, snowfall or hail
  - Storm or high wind
  - Extremely low or high temperature
  - High humidity of the air



## 5.2 Donor Antenna Installation Guidelines

- Accurately determine the azimuth to the donor site. Obtain the donor site information and approval from the service provider/carrier.
- Ensure that the radiation path to the donor site is unobstructed.
- Mount the donor antenna at or toward the edge of the roof, in the direction of the donor site. Avoid having the RF signal from the donor pass above the location(s) of the service antennas. Normally, the service antennas are installed behind and below the donor antenna, as viewed from above. This approach helps avoid interference and feedback to and from the service antennas.
- Normally, mounting the donor antenna higher will allow a less obstructed path to the donor site. However, in high traffic metro areas, avoid mounting the donor antenna higher than necessary, as the quality of the donor signal may become less stable and it is more likely to encounter adjacent channel interference.
- When possible, shield the rear of a donor antenna by locating it so that any HVAC units and/or penthouse structures are behind the antenna, relative to the donor cell site location.

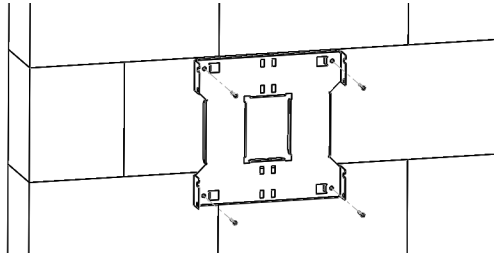
## 5.3 Indoor Antenna Installation Guidelines

- Use omnidirectional antennas (see section 2.4. Optional Accessories) indoors and locate them centrally with respect to the intended coverage area to minimize signal leakage to the outside. Only use directional antennas indoors in special cases when higher gain and directionality would be helpful and RF exposure limits will not be exceeded.
- To avoid Signal Booster uplink overload and gain limiting, mount the indoor antennas away from areas where mobile subscribers frequently use their phones / radios, such as desks or dispatch areas.
- To determine the quantity and locations of indoor antennas, measure Received Signal Strength Indication (RSSI) using DM Tool software to determine areas of weak signals. These are the approximate areas where indoor antennas may be needed.
- Be aware that the signal from an indoor antenna, in most cases, can be expected to penetrate approximately two standard sheet rock walls to reach users. If the signal must travel through more than two walls, or if the walls are made of materials other than sheet rock, it may be necessary to split the available signal and add more antennas.

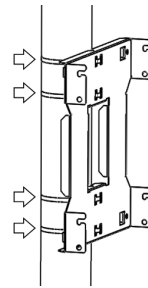
## 5.4 Mounting the Signal Booster

### A. Mount the bracket

The Signal Booster can be mounted on a wall or pole. The bracket is provided with the Signal Booster.

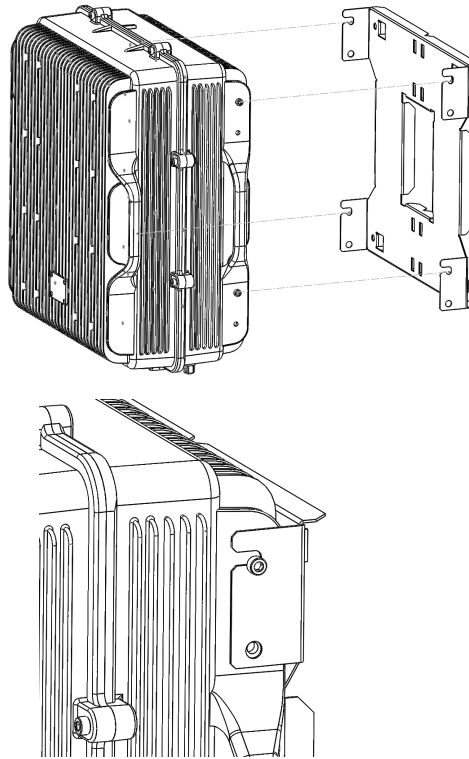


**Figure:** *Bracket attachment to a wall using three fixing screws*



**Figure:** *Bracket attachment to a pipe using four inox hose clamps*

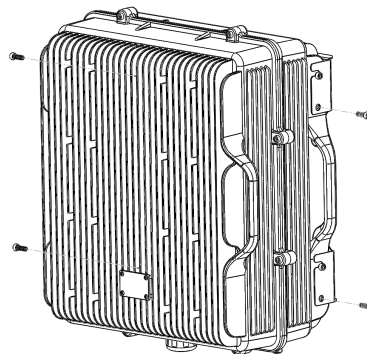
B. After attaching the bracket hang the Signal Booster.



**Figure:** *Hang the Signal Booster*

C. Secure the cabinet to the bracket.

To attach the Signal Booster's cabinet to the bracket use the provided four M6 x 1/2" allen screws and follow the indicated steps:

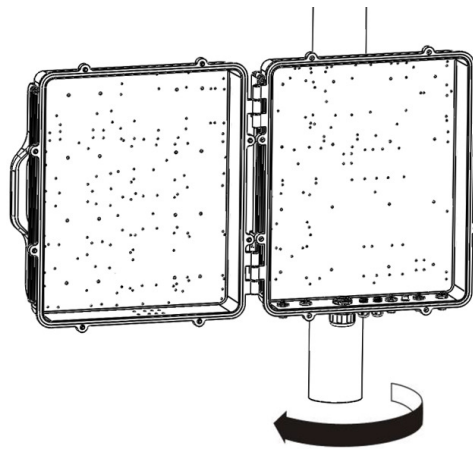


**Figure:** *Secure the cabinet to the bracket*

D. To open the cabinet, release the 8 door screws using the provided special allen key.



**Figure:** Release Signal Booster cover



**Figure:** Open the Signal Booster

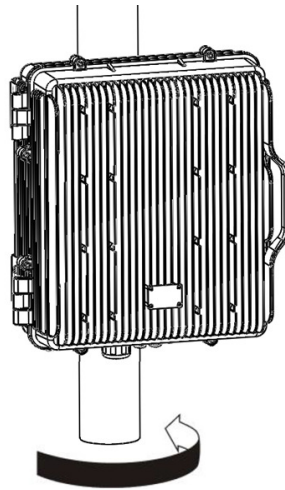


Figure: Close the Signal Booster

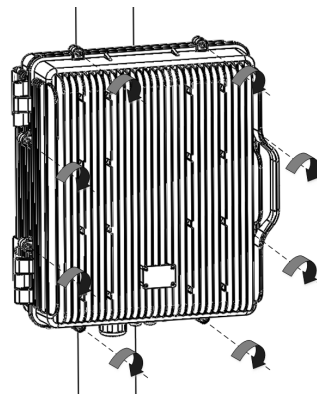
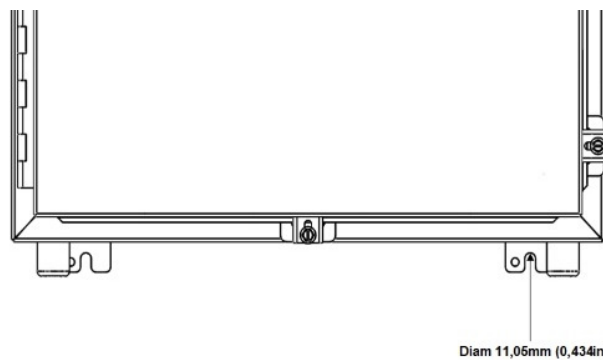


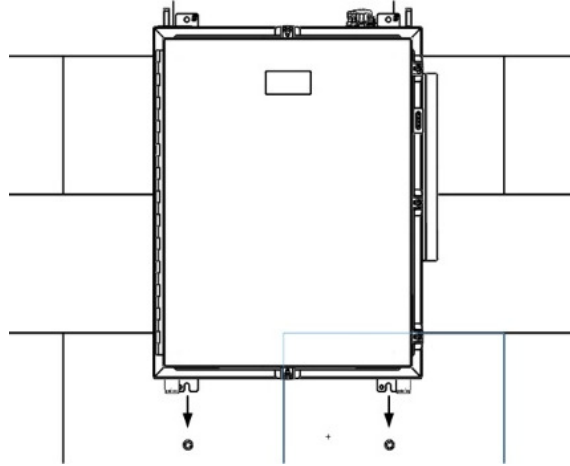
Figure: Secure Signal Booster

### Mounting Cabinet WST021

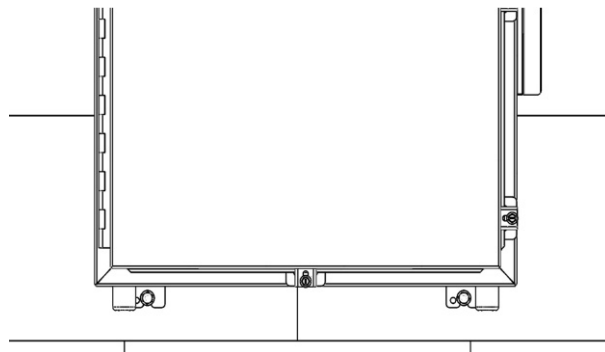
A. This cabinet can be mounted on a wall.



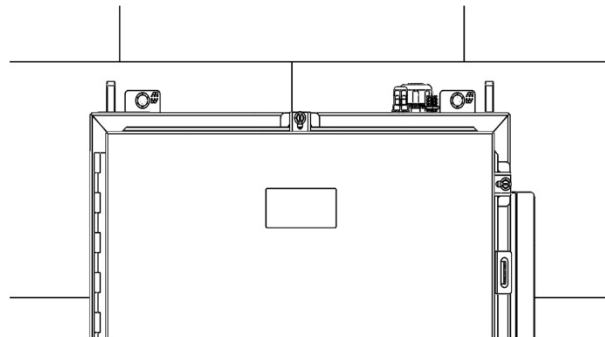
**Figure:** *Secure Signal Booster*



**Figure:** *Hang the Signal Booster*

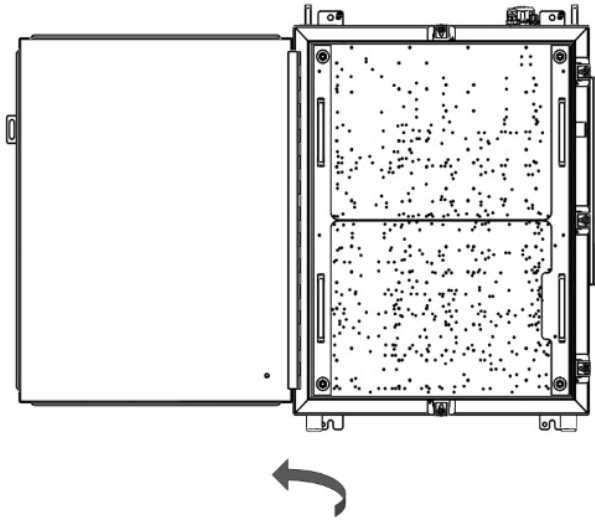


**Figure:** *Secure Signal Booster cover*

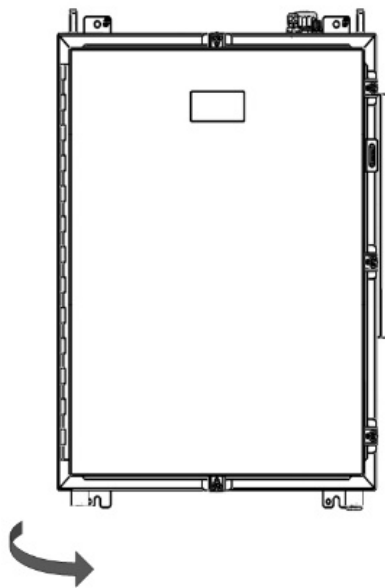


**Figure:** *Secure Signal Booster cover*

B. To open the cabinet, release the door screws using a flat screw driver.



**Figure:** *Open the Signal Booster cover*



**Figure:** *Close the Signal Booster cover*



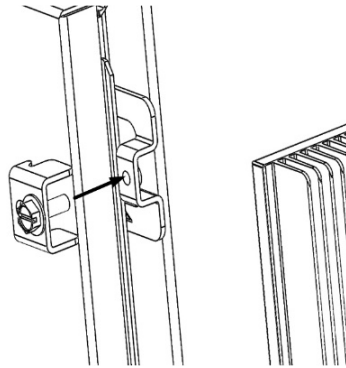


Figure: Secure Signal Booster cover

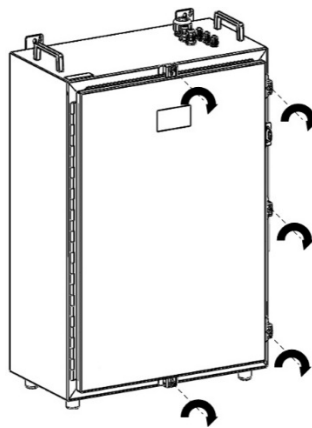


Figure: Secure Signal Booster cover

### Use of Liquid Tight Conduit

The unit has available a Liquid Tight Conduit Fitting connector for ¼" tubes. The unit as standard has the connector installed, so if the user requires to use this connector, if available, the NFPA cables, Ethernet, DC or AC cables can be routed through this connector.

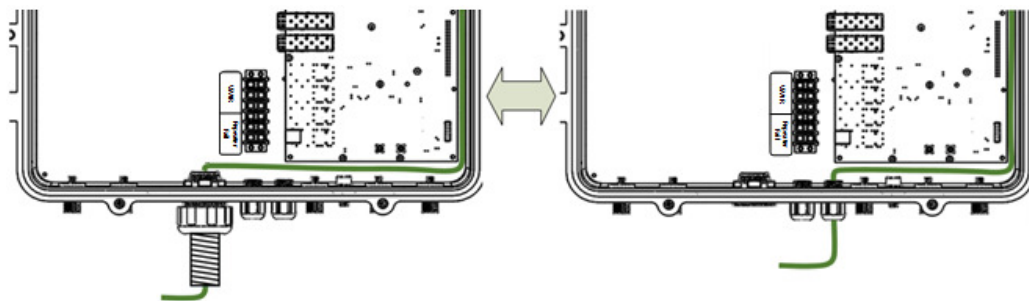


Figure: AC Routing through cable gland or conduit connector

If the is not going to use Liquid Tight Conduits, then the connector should be replaced by the provided sealing cup.

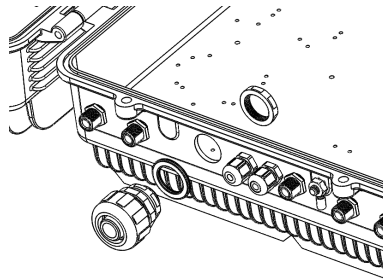


Figure: Remove the conduit connector

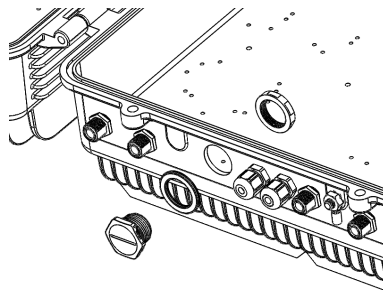


Figure: Install the sealing cup

#### Replacement of Conduit connector to sealing cup

##### NEMA4 considerations

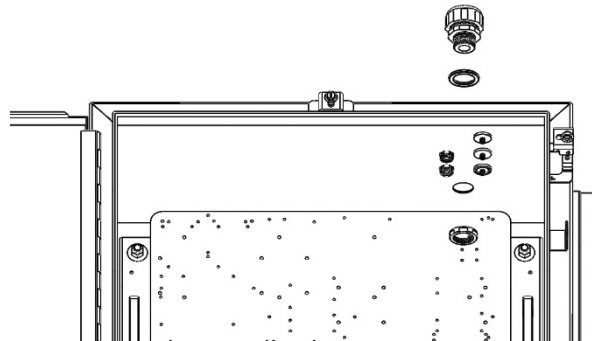
This device is equipped with a NEMA4 enclosure, however, to ensure the NEMA rating, the user must have the following considerations:

1. Correct use of the Liquid Tight Conduit. In case this interface is not used, it should be replaced with the sealing cup.
2. Sealing cups should be installed in the non-used cable glands.
3. The RF Ports should be perfectly mated.

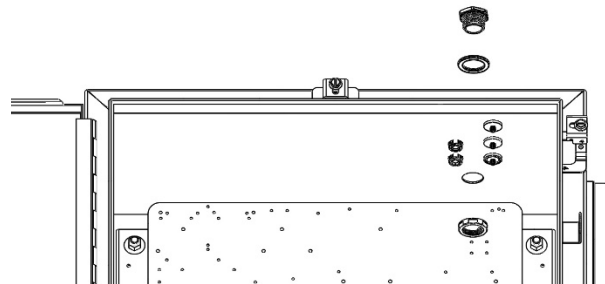
## Mounting Cabinet WST021

The unit has available a Liquid Tight Conduit Fitting connector for  $\frac{3}{4}$ " tubes. The unit as standard has the connector installed, so if the user requires to use this connector, if available, the NFPA cables, Ethernet, DC or AC cables can be routed through this connector.

If the is not going to use Liquid Tight Conduits, then the connector should be replaced by the provided sealing cup.



**Figure:** *Remove the conduit connector*



**Figure:** *Install the sealing cup*

### Replacement of Conduit connector to sealing cup

#### NEMA4 considerations

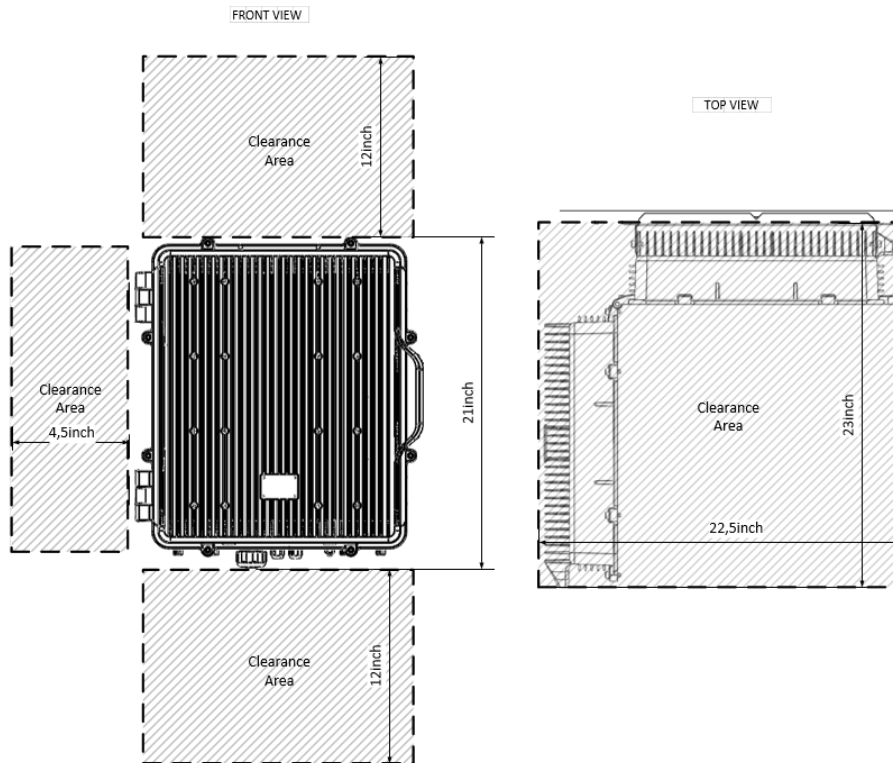
This device is equipped with a NEMA4 enclosure, however, to ensure the NEMA rating, the user must have the following considerations:

1. Correct use of the Liquid Tight Conduit. In case this interface is not used, it should be replaced with the sealing cup.
2. Sealing cups should be installed in the non-used cable glands.
3. The RF Ports should be perfectly mated.



### Mounting clearance

When mounting the cabinet, the clearances around it should be considered to allow a clear open door and heat dissipation.



**Figure:** *Mounting clearance WST012*

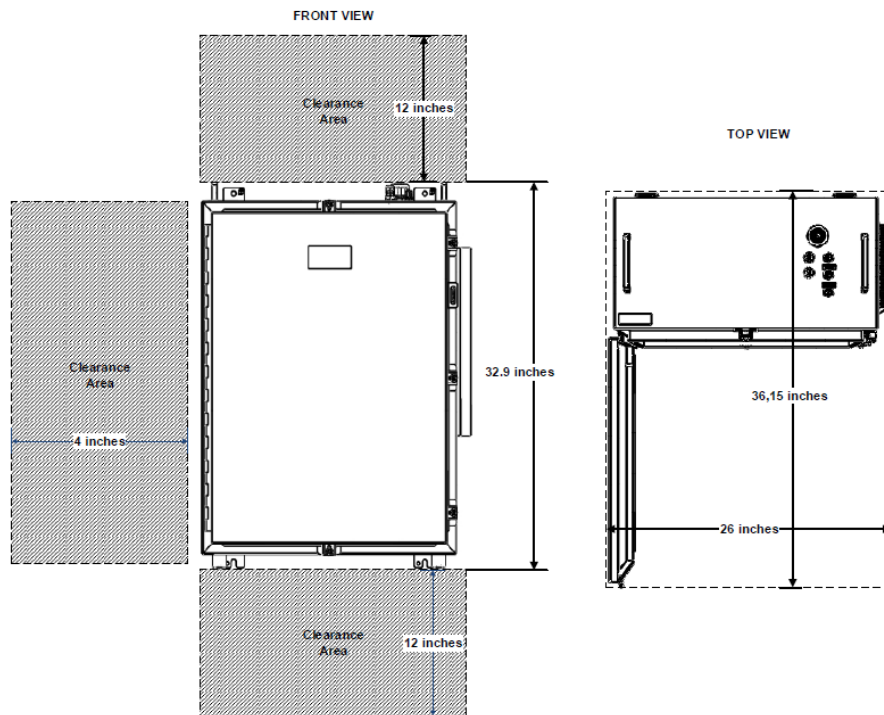


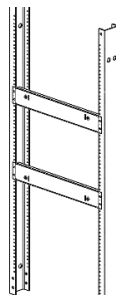
Figure: Mounting clearance WST021

### Rack mount option

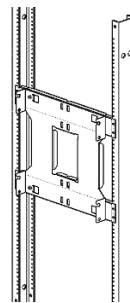
Even though this cabinet is designed mainly to be wall or pole mounted, it has the option to be installed in a 19" standard rack using the Rack Mount Option.

The Rack Mount Option are adaptors that allow the installation of the cabinet bracket to the 19" rack.

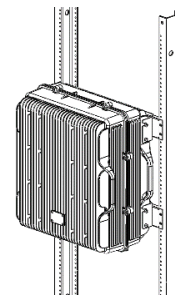
It is recommended to use 2 post racks, this way, using back-to-back installation, 4 cabinets can be installed in a single 2 post RU rack.



Mount the 19" rack adaptors.



Mount the cabinet bracket to the adaptors.

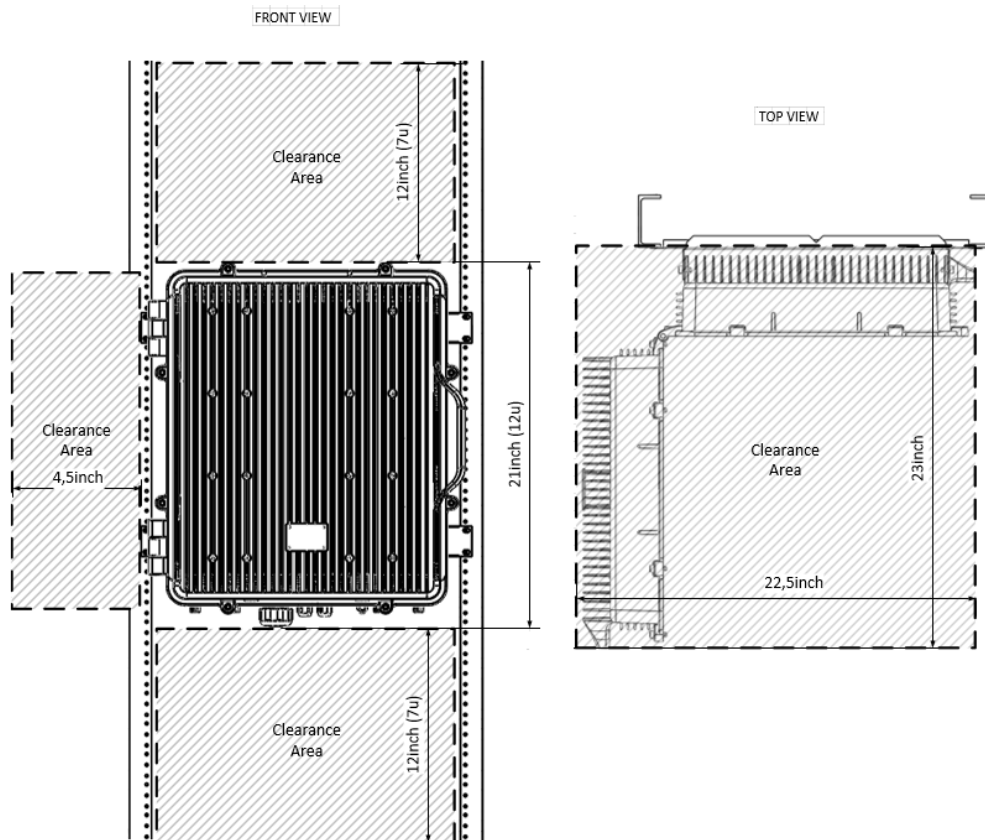


Mount and Fix the Signal Booster to the bracket.

**Figure:** *Installation steps for the rack mount option WST012*

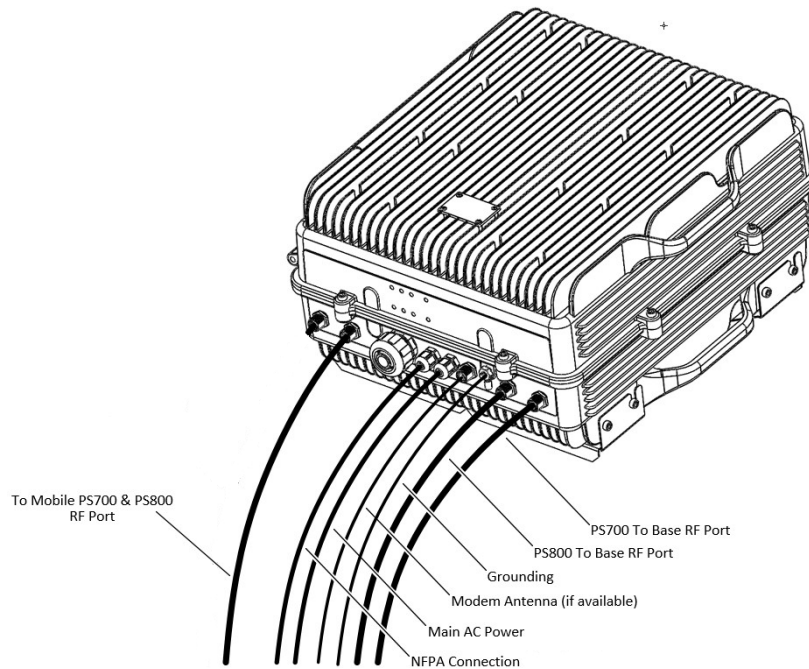
### Mounting clearance on rack mount option

When mounting the cabinet in a 19" rack, the clearances around it should be considered to allow a clear open door and heat dissipation.



**Figure:** *Mounting clearance for the rack mount option WST012*

## 6 Connecting the Signal Booster



**Figure:** *RF ports and Power Cable Glands location*

### 6.1 Connection step by step

A. RF Ports: Connect the service antennas to the To Mobile Port and each PS700 and PS800 donor antennas to the To Base RF Ports. N type female connectors are used in this Signal Booster.

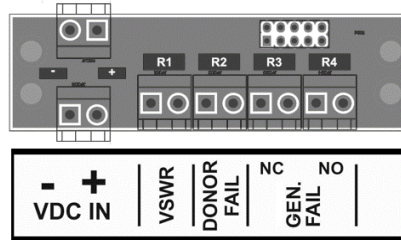
B. Once the RF ports of the Signal Booster are properly loaded connect the Main AC power. If using the AC model, electrical installation must provide differential and thermo-magnetic breaker elements according to electric safety international regulations.

C. Make sure that not used cable glands are properly sealed. For this, use the seal plug and self-amalgamating tape.

D. Auxiliary DC connection can be provided to the device from an external DC source. There is a dedicated port for this purpose, and a dedicated DC connector labelled "VDC IN" located inside the cabinet. Please check appropriate DC voltage at Signal Booster specification sheet.



E. NFPA Dry Contacts: there is a dedicated cable gland for this purpose. A multi-conductor cable can be used to connect the NFPA dry contacts to the Fire Department Control Box.



**Figure:** *NFPA Dry Contact connection location inside the cabinet*

F. Once the Signal Booster is connected to the power source, it takes about 40 seconds to run a booting routine. After that time, the Signal Booster is ready to be connected via USB cable to a computer running Westell Control Software (WCS) to be properly configured.

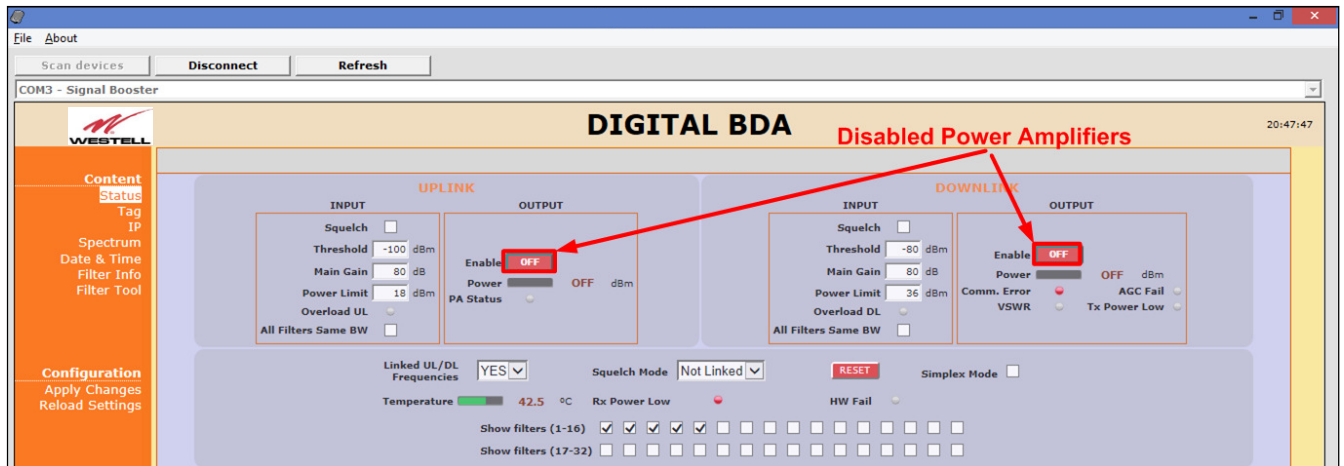
## 7 System Operation



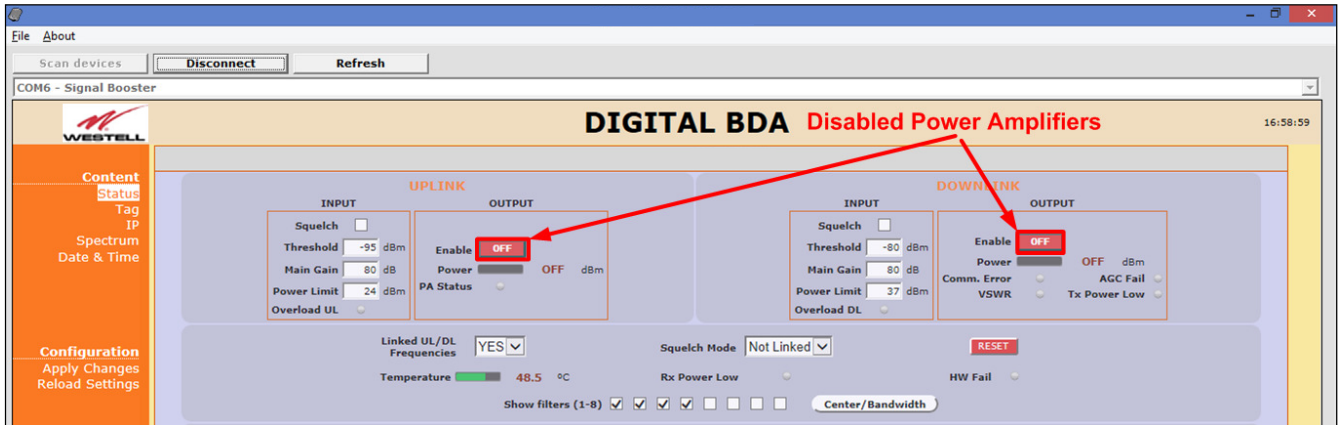
**BE SURE THAT “TO MOBILE” AND “TO BASE” PORTS ARE PROPERLY LOADED EITHER WITH 50 OHMS DUMMY LOADS, OR RADIATING SYSTEM.**

The Digital Signal Booster may come in one out of two versions: a 32 narrow-band filters version or an up-to-8 adjustable-bandwidth filters version. It is even possible to have both versions in one device so that the user can choose either of them. Depending on which version is actually running, the main screen of the Westell Control Software will have a slightly different look.

1. Turn on the Digital Signal Booster, connect computer to Signal Booster through Ethernet or USB cable, and run Westell Control Software. It is recommend to turn off the power amplifiers.



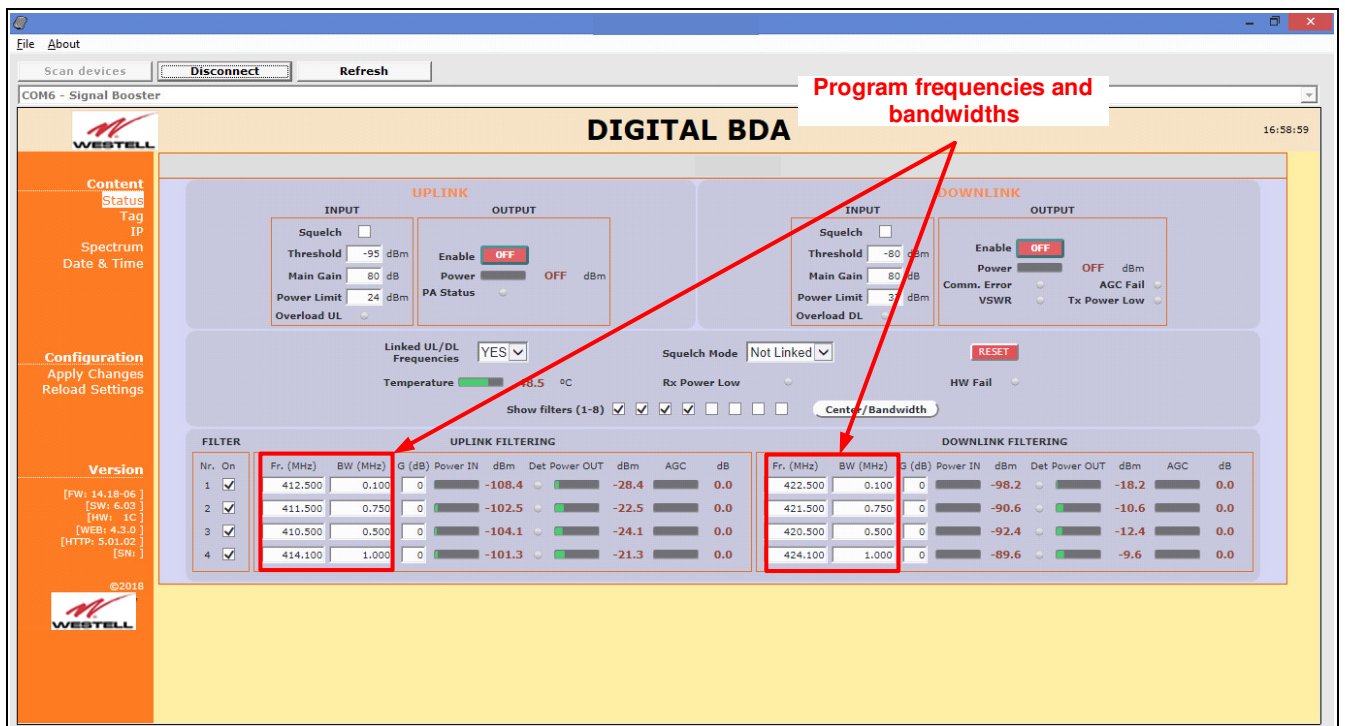
PA OFF in narrow-band version



PA OFF in adjustable bandwidth version

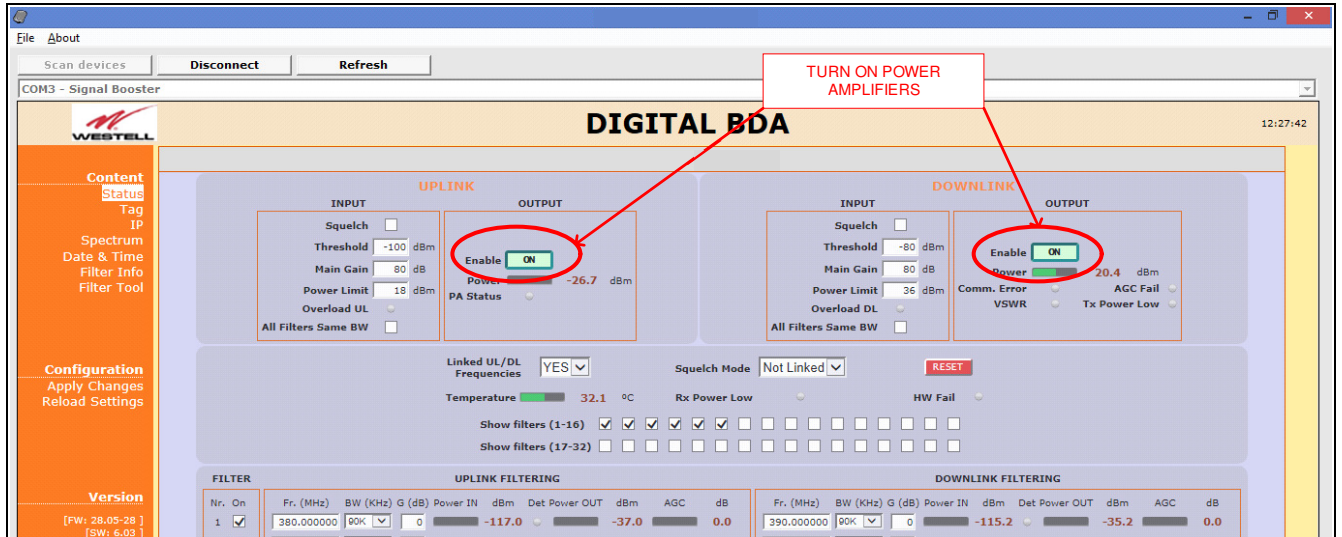
2. Setup desired channel frequencies. Since Westell Signal Booster is channel selective, user has to know what frequencies are used in base station.

Narrow-band filter frequency settings

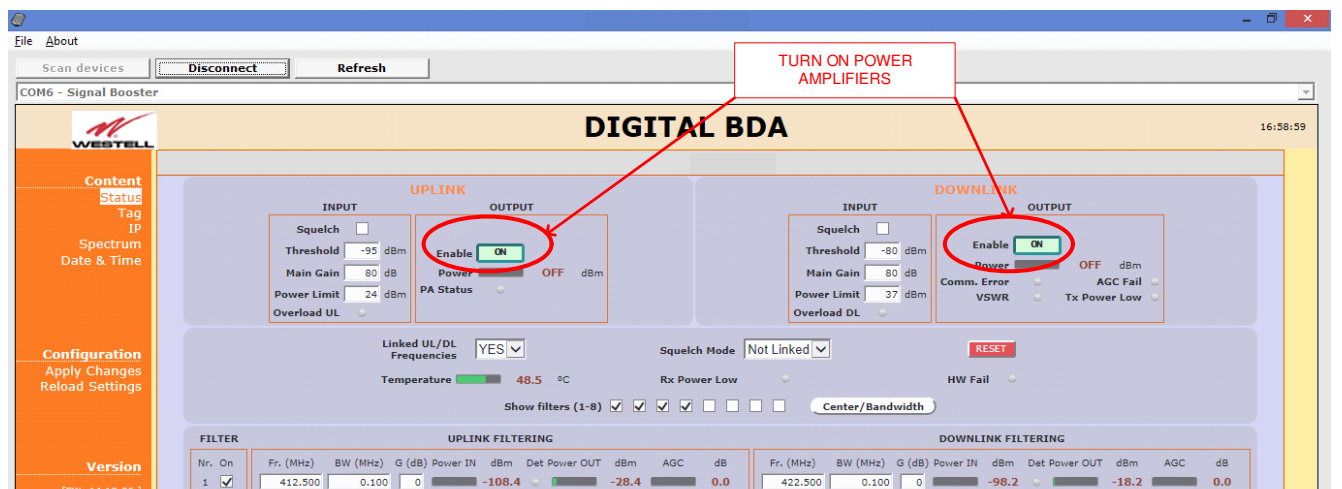


Frequency and Bandwidth settings

3. Turn on UL and DL power amplifiers, and check that any alarm indicator is active.



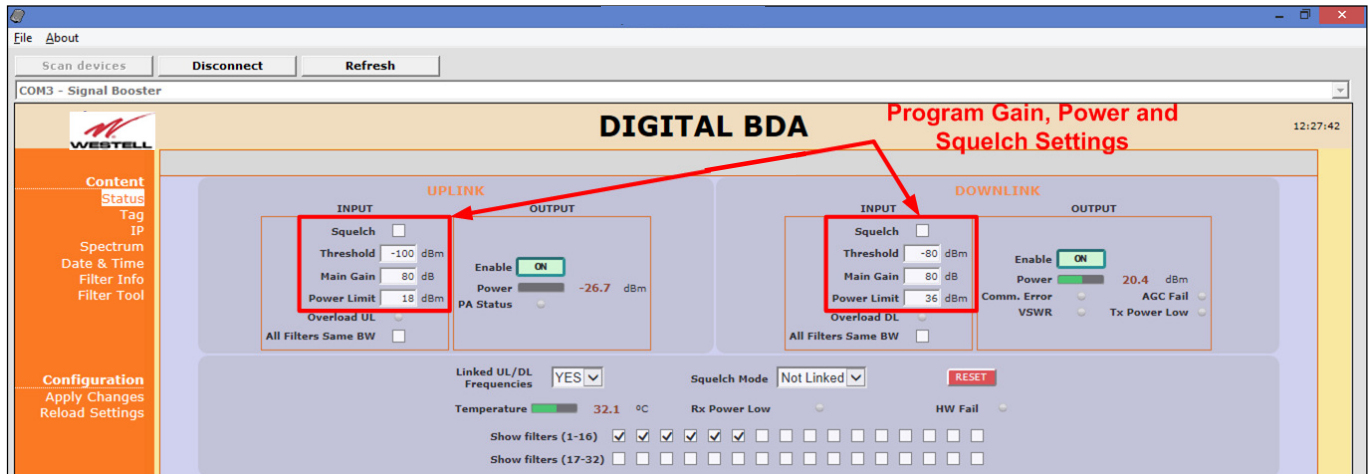
PA ON in narrow band version



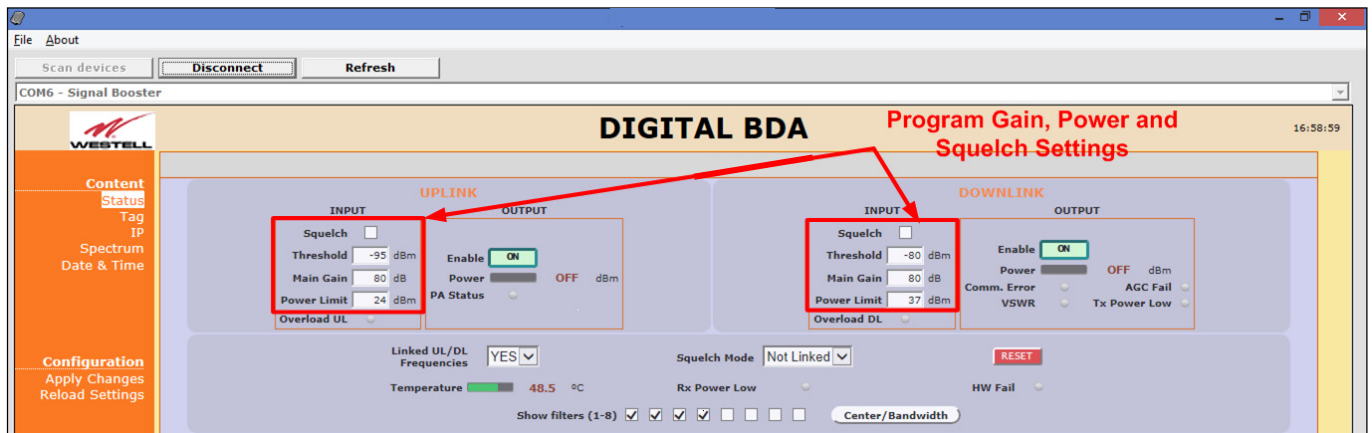
PA ON in adjustable bandwidth version

4. Setup desired operating gain using FCS. UL and DL chain are independent, so both values must be set. To set DL band gain is recommended that AGC works around 3dB in each channel, in this way, maximum output power is achieved.

5. Set up squelch settings. Controls are independent in UL and DL bands. Typical values for UL are -110dBm for squelch threshold. For DL, recommended value for squelch threshold is minimum level received in any active channel minus 10dB.

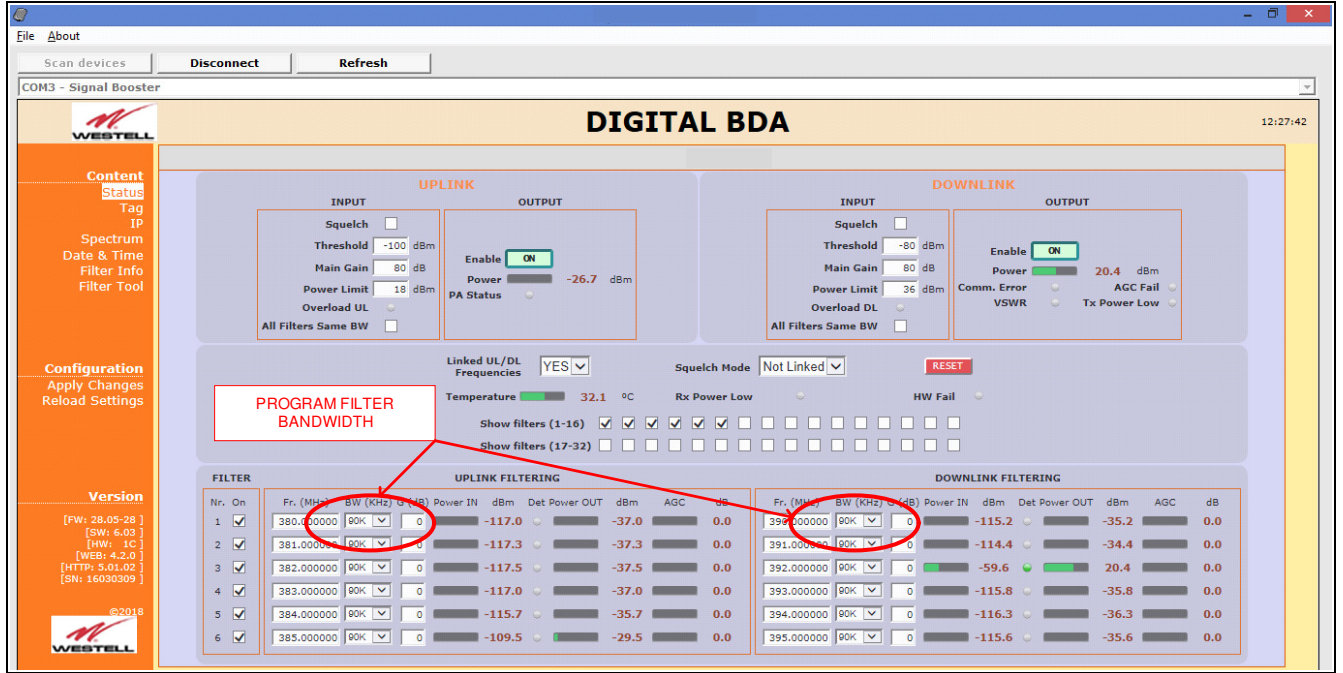


Squelch, gain and power settings: narrow band



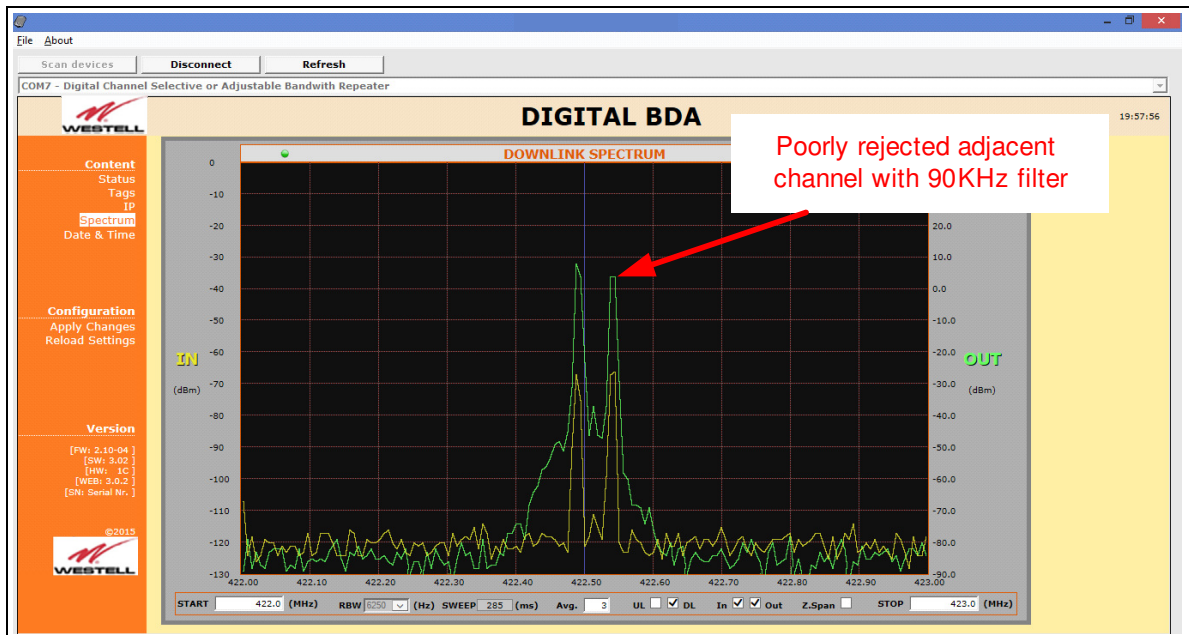
Squelch, gain and power settings: adjustable bandwidth

6. For narrow band filters version, setup desired filter bandwidth, depending on presence of adjacent channels. In principle, recommended bandwidth filter is 90KHz due to its low delay, but if adjacent signal is detected, narrow filters can be used. Spectrum analyzer of FCS can be used to know rejection to undesired signals. It is recommend that adjacent channels output power be, at least, 10dBc lower than useful carrier.

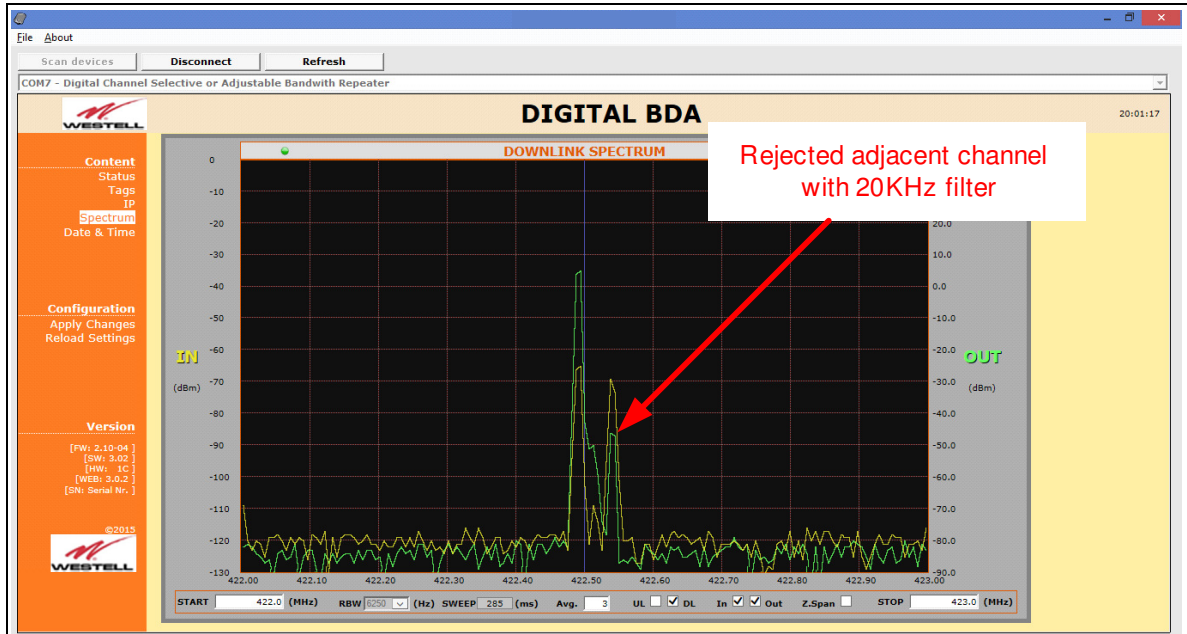


Filter bandwidth selection for narrow band filters version

Next figures, shows how integrated spectrum analyzer can help to select bandwidth filters:



Adjacent channel rejection with 90KHz filter



Adjacent channel rejection with 20KHz filter

## 8 Status Indicators

There is an indicator panel located at bottom of the Signal Boosters. This LED panel works as a status monitor, in order indicate warning or alarms of Signal Booster.

The LED panel has four LEDs, the first one the power ON indication led, labelled “PWR”.

The Second LED, labelled “STS” summarizes warnings regarding critical operational conditions of the Signal Booster.

The third and fourth LED summarizes operational conditions for uplink “UL” and downlink “DL” chains.

In general, the LEDs have four states: “off”, “slow blinking”, “fast blinking” and “on”. Next table describes alarm and warning conditions for each led state.



<i>Indicator Panel</i>	<i>LED indication description</i>
------------------------	-----------------------------------