



ULTRA HEATWAVE™
TECHNOLOGY

Speedcook Microwave Hood Combination with Convection

Use & Care Guide

Combinación microondas campana de cocción veloz con convección

Manual de uso y cuidado

Models/Modelos 228853

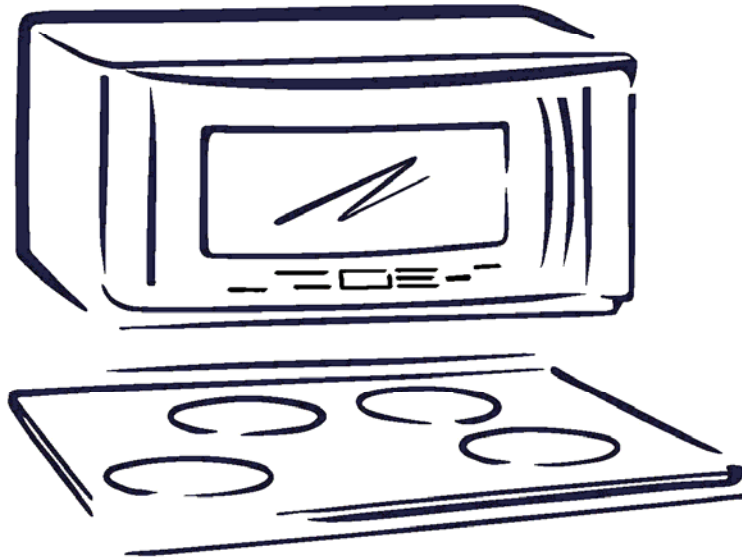

ENGLISH ESPAÑOL

W10220014A

Sears Roebuck and Co., Hoffman Estates, IL 60179 U.S.A.

www.sears.com

TABLE OF CONTENTS

WARRANTY	3	MANUAL COOKING	17
PROTECTION AGREEMENTS	3	Add a Minute	17
MICROWAVE HOOD COMBINATION SAFETY	4	MWO Time/Power Cooking	17
Electrical Requirements.....	5	Convect Time/Temp Cooking	17
PARTS AND FEATURES	6	Manual Method Cooking	18
Microwave Oven Cavity Coating.....	6	Cooking in Stages (or steps)	18
Ultra Heatwave Technology™	6	Raising (Proofing) Bread.....	19
Grill Element	6	Warm Hold.....	19
Convection Element and Fan.....	7	PROGRAMMED COOKING	20
Turntable.....	7	Convection Cooking.....	20
ACCESSORIES	8	Combination Cooking.....	20
Steamer Vessel.....	8	Sensor Cooking	20
Browning Pan and Handle	8	Preheating.....	20
Grill Rack	8	Doneness	20
Convection Rack	8	Popcorn Sensor.....	21
MICROWAVE OVEN CONTROL	9	Using Food Type	21
Control Panel.....	9	Using Cook Method	21
Interactive Touch Display.....	9	Reheat.....	21
Main Menu.....	10	Defrost	22
Settings & Info	11	Cook.....	22
Clock.....	12	Bake	22
Date	12	Boil & Simmer	23
Demo Mode.....	12	Browning Pan	23
Display Backlight.....	12	Grill.....	24
Display Contrast.....	12	Melt	24
Learning Mode.....	12	Roast.....	24
Tones	13	Soften.....	24
Start	13	Steam Cook.....	25
Stop	13	Favorites Menu	25
Clear.....	13	Food Type Chart.....	26
Timer.....	13	Cook Method Chart.....	28
Control Lock	14	MICROWAVE OVEN CARE	32
Vent Fan and Cooktop Lights	14	General Cleaning	32
Cooking Animation	14	Replacing Filters	33
Progress Bar.....	14	Replacing Cooktop Light.....	33
MICROWAVE OVEN USE	15	Replacing Microwave Oven Light	34
Food Characteristics	15	Replacement Parts	34
Cooking Guidelines	15	TROUBLESHOOTING	35
Cookware and Dinnerware.....	15	SERVICE NUMBERS	BACK COVER
Aluminum Foil and Metal.....	16		
Microwave Cooking Power	16		

KENMORE ELITE® APPLIANCE WARRANTY

ONE YEAR LIMITED WARRANTY

When installed, operated and maintained according to all instructions supplied with the product, if this appliance fails due to a defect in material or workmanship within one year from the date of purchase, call 1-800-4-MY-HOME® to arrange for free repair.

FIVE-YEAR LIMITED WARRANTY ON THE MAGNETRON

For five years from the date of purchase, when this speed cook oven is installed, operated and maintained according to all instructions supplied with the product, Sears will replace the magnetron free of charge due to defective materials or workmanship.

If this appliance is used for other than private family purposes, this warranty applies for only 90 days from the date of purchase.

THIS WARRANTY COVERS ONLY DEFECTS IN MATERIAL AND WORKMANSHIP. SEARS WILL NOT PAY FOR:

1. Expendable items that can wear out from normal use, including but not limited to filters, belts, light bulbs, and bags.
2. A service technician to instruct the user in correct product installation, operation or maintenance.
3. A service technician to clean or maintain this product.
4. Damage to or failure of this product if it is not installed, operated or maintained according to all instructions supplied with the product.
5. Damage to or failure of this product resulting from accident, abuse, misuse or use for other than its intended purpose.
6. Damage to or failure of this product caused by the use of detergents, cleaners, chemicals or utensils other than those recommended in all instructions supplied with the product.
7. Damage to or failure of parts or systems resulting from unauthorized modifications made to this product.

DISCLAIMER OF IMPLIED WARRANTIES; LIMITATION OF REMEDIES

Customer's sole and exclusive remedy under this limited warranty shall be product repair as provided herein. Implied warranties, including warranties of merchantability or fitness for a particular purpose, are limited to one year or the shortest period allowed by law. Sears shall not be liable for incidental or consequential damages. Some states and provinces do not allow the exclusion or limitation of incidental or consequential damages, or limitations on the duration of implied warranties of merchantability or fitness, so these exclusions or limitations may not apply to you.

This warranty applies only while this appliance is used in the United States and Canada.

This warranty gives you specific legal rights, and you may also have other rights which vary from state to state.

Sears, Roebuck and Co.
Dept. 817WA, Hoffman Estates, IL 60179

Sears Canada Inc.
Toronto, Ontario, Canada M5B 2B8

PRODUCT RECORD

Record your complete model number, serial number, and purchase date. You can find this information on the model and serial number label located on the product.

Have this information available to help you obtain assistance or service more quickly whenever you contact Sears concerning your appliance.

Model number _____

Serial number _____

Purchase date _____

Save these instructions and your sales receipt for future reference.

PROTECTION AGREEMENTS

Master Protection Agreements

Congratulations on making a smart purchase. Your new Kenmore® product is designed and manufactured for years of dependable operation. But like all products, it may require preventive maintenance or repair from time to time. That's when having a Master Protection Agreement can save you money and aggravation.

The Master Protection Agreement also helps extend the life of your new product. Here's what the Agreement* includes:

- ✓ **Parts and labor** needed to help keep products operating properly **under normal use**, not just defects. Our coverage goes **well beyond the product warranty**. No deductibles, no functional failure excluded from coverage— **real protection**.
- ✓ **Expert service** by a force of more than 10,000 authorized **Sears service technicians**, which means someone you can trust will be working on your product.
- ✓ **Unlimited service calls and nationwide service**, as often as you want us, whenever you want us.
- ✓ **"No-lemon" guarantee** – replacement of your covered product if four or more product failures occur within twelve months.
- ✓ **Product replacement** if your covered product can't be fixed.
- ✓ **Annual Preventive Maintenance Check** at your request – no extra charge.
- ✓ **Fast help by phone** – we call it **Rapid Resolution** – phone support from a Sears representative on all products. Think of us as a "talking owner's manual."
- ✓ **Power surge protection** against electrical damage due to power fluctuations.
- ✓ **\$250 Food Loss Protection** annually for any food spoilage that is the result of mechanical failure of any covered refrigerator or freezer.
- ✓ **Rental reimbursement** if repair of your covered product takes longer than promised.
- ✓ **10% discount** off the regular price of any non-covered repair service and related installed parts.

Once you purchase the Agreement, a simple phone call is all that it takes for you to schedule service. You can call anytime day or night, or schedule a service appointment online.

The Master Protection Agreement is a risk free purchase. If you cancel for any reason during the product warranty period, we will provide a full refund. Or, a prorated refund anytime after the product warranty period expires. Purchase your Master Protection Agreement today!

Some limitations and exclusions apply. For prices and additional information in the U.S.A. call 1-800-827-6655.

Sears Installation Service

For Sears professional installation of home appliances, garage door openers, water heaters, and other major home items, in the U.S.A. call **1-800-4-MY-HOME®**.

MICROWAVE HOOD COMBINATION SAFETY

Your safety and the safety of others are very important.

We have provided many important safety messages in this manual and on your appliance. Always read and obey all safety messages.



This is the safety alert symbol.

This symbol alerts you to potential hazards that can kill or hurt you and others.

All safety messages will follow the safety alert symbol and either the word “DANGER” or “WARNING.”

These words mean:

⚠ DANGER

You can be killed or seriously injured if you don't immediately follow instructions.

⚠ WARNING

You can be killed or seriously injured if you don't follow instructions.

All safety messages will tell you what the potential hazard is, tell you how to reduce the chance of injury, and tell you what can happen if the instructions are not followed.

IMPORTANT SAFETY INSTRUCTIONS

When using electrical appliances basic safety precautions should be followed, including the following:

WARNING: To reduce the risk of burns, electric shock, fire, injury to persons, or exposure to excessive microwave energy:

- Read all instructions before using the microwave oven.
- Read and follow the specific “PRECAUTIONS TO AVOID POSSIBLE EXPOSURE TO EXCESSIVE MICROWAVE ENERGY” found in this section.
- The microwave oven must be grounded. Connect only to properly grounded outlet. See “GROUNDING INSTRUCTIONS” found in this section and in the provided Installation Instructions.
- Install or locate the microwave oven only in accordance with the provided Installation Instructions.
- Some products such as whole eggs in the shell and sealed containers – for example, closed glass jars – are able to explode and should not be heated in the microwave oven.
- Use the microwave oven only for its intended use as described in this manual. Do not use corrosive chemicals or vapors in the microwave oven. This type of oven is specifically designed to heat, cook, or dry food. It is not designed for industrial or laboratory use.
- As with any appliance, close supervision is necessary when used by children.
- Do not operate the microwave oven if it has a damaged cord or plug, if it is not working properly, or if it has been damaged or dropped.
- The microwave oven should be serviced only by qualified service personnel. Call an authorized service company for examination, repair, or adjustment.
- See door surface cleaning instructions in the “Microwave Oven Care” section.
- To reduce the risk of fire in the oven cavity:
 - Do not overcook food. Carefully attend the microwave oven when paper, plastic, or other combustible materials are placed inside the oven to facilitate cooking.
 - Remove wire twist-ties from paper or plastic bags before placing bags in oven.
 - If materials inside the oven ignite, keep oven door closed, turn oven off, and disconnect the power cord, or shut off power at the fuse or circuit breaker panel.
 - Do not use the cavity for storage purposes. Do not leave paper products, cooking utensils, or food in the cavity when not in use.
- Liquids, such as water, coffee, or tea are able to be overheated beyond the boiling point without appearing to be boiling. Visible bubbling or boiling when the container is removed from the microwave oven is not always present. THIS COULD RESULT IN VERY HOT LIQUIDS SUDDENLY BOILING OVER WHEN THE CONTAINER IS DISTURBED OR A SPOON OR OTHER UTENSIL IS INSERTED INTO THE LIQUID.
 - To reduce the risk of injury to persons:
 - Do not overheat the liquid.
 - Stir the liquid both before and halfway through heating it.
 - Do not use straight-sided containers with narrow necks.
 - After heating, allow the container to stand in the microwave oven for a short time before removing the container.
 - Use extreme care when inserting a spoon or other utensil into the container.
- Oversized foods or oversized metal utensils should not be inserted in the microwave oven as they may create a fire or risk of electric shock.
- Do not clean with metal scouring pads. Pieces can burn off the pad and touch electrical parts involving a risk of electric shock.

SAVE THESE INSTRUCTIONS

IMPORTANT SAFETY INSTRUCTIONS

- Suitable for use above both gas and electric cooking equipment.
- Intended to be used above ranges with maximum width of 36" (91.44 cm).
- Clean Ventilating Hoods Frequently - Grease should not be allowed to accumulate on hood or filter.
- Do not use paper products when appliance is operated in convection, combination, grill or "PAN BROWN" mode (on models with such features).
- Do not store any materials, other than manufacturer's recommended accessories, in this oven when not in use.
- Do not store anything directly on top of the microwave oven when the microwave oven is in operation.
- When flambeing foods under the hood, turn the fan on.
- Use care when cleaning the vent-hood filter. Corrosive cleaning agents, such as lye-based oven cleaners, may damage the filter.
- Do not cover or block any openings on the microwave oven.
- Do not store this microwave oven outdoors. Do not use the microwave oven near water - for example, near a kitchen sink, in a wet basement, or near a swimming pool, or similar locations.
- Do not immerse cord or plug in water.
- Keep cord away from heated surfaces.
- Do not let cord hang over edge of table or counter.
- Do not mount over a sink.
- Do not cover racks or any other part of the oven with metal foil. This will cause overheating of the oven.

SAVE THESE INSTRUCTIONS

PRECAUTIONS TO AVOID POSSIBLE EXPOSURE TO EXCESSIVE MICROWAVE ENERGY

- (a) Do not attempt to operate this oven with the door open since open-door operation can result in harmful exposure to microwave energy. It is important not to defeat or tamper with the safety interlocks.
- (b) Do not place any object between the oven front face and the door or allow soil or cleaner residue to accumulate on sealing surfaces.
- (c) Do not operate the oven if it is damaged. It is particularly important that the oven door close properly and that there is no damage to the:
 - (1) Door (bent),
 - (2) Hinges and latches (broken or loosened),
 - (3) Door seals and sealing surfaces.
- (d) The oven should not be adjusted or repaired by anyone except properly qualified service personnel.

ENGLISH

Electrical Requirements

⚠ WARNING



Electrical Shock Hazard

Plug into a grounded 3 prong outlet.

Do not remove ground prong.

Do not use an adapter.

Do not use an extension cord.

Failure to follow these instructions can result in death, fire, or electrical shock.

Observe all governing codes and ordinances.

Required:

- A 120 Volt, 60 Hz, AC only, 15- or 20-amp electrical supply with a fuse or circuit breaker.

Recommended:

- A time-delay fuse or time-delay circuit breaker.
- A separate circuit serving only this microwave oven.

GROUNDING INSTRUCTIONS

■ For all cord connected appliances:

The microwave oven must be grounded. In the event of an electrical short circuit, grounding reduces the risk of electric shock by providing an escape wire for the electric current. The microwave oven is equipped with a cord having a grounding wire with a grounding plug. The plug must be plugged into an outlet that is properly installed and grounded.

WARNING: Improper use of the grounding plug can result in a risk of electric shock. Consult a qualified electrician or serviceman if the grounding instructions are not completely understood, or if doubt exists as to whether the microwave oven is properly grounded.

Do not use an extension cord. If the power supply cord is too short, have a qualified electrician or serviceman install an outlet near the microwave oven.

SAVE THESE INSTRUCTIONS

This device complies with Part 18 of the FCC Rules.

PARTS AND FEATURES

This manual may cover several different models. The model you have purchased may have some or all of the features shown here. The appearance of your particular model may differ slightly from the illustrations in this manual.

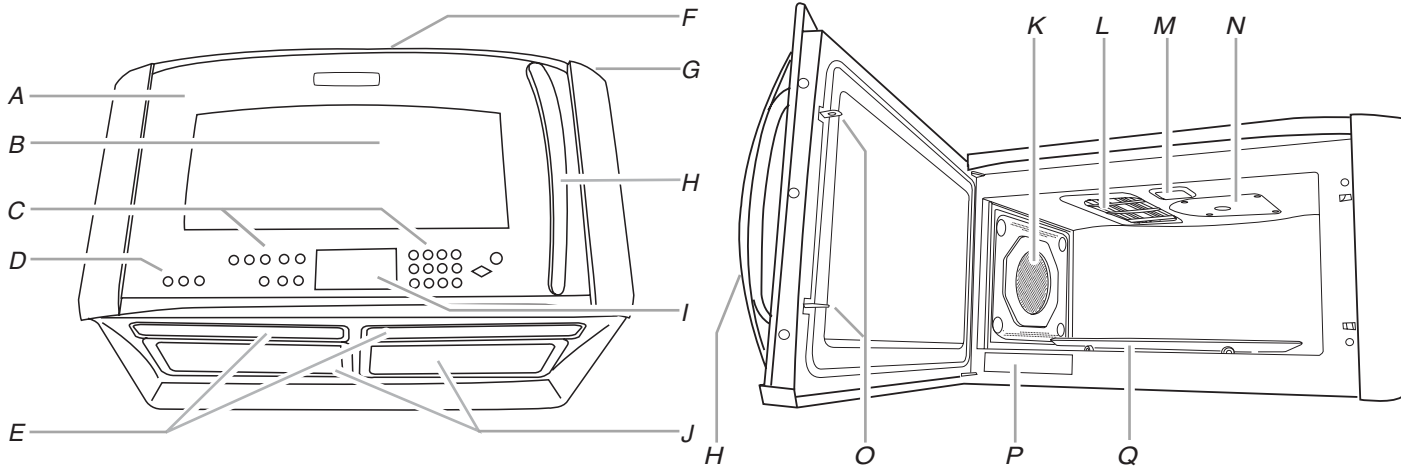

- | | | | |
|--------------------------------|---------------------------------------------------------------------|-----------------------------------------------|----------------------------------|
| A. Microwave oven door | F. Exhaust vent (for recirculation) (top surface of microwave oven) | J. Grease and charcoal filters (2 each) | N. Microwave inlet cover |
| B. Window | G. Intake vent | K. Convection element and fan (behind screen) | O. Door lock system |
| C. Control panel | H. Door handle | L. Grill element | P. Model and serial number plate |
| D. Lights and Vent Fan buttons | I. Interactive touch display | M. Microwave oven light | Q. Turntable |
| E. Halogen cooktop lights (2) | | | |

Microwave Oven Cavity Coating

The microwave oven has a durable, nonstick coating that resists soil buildup by making cleaning easier than in conventional microwave ovens. See "General Cleaning" section for cleaning instructions.

Ultra Heatwave Technology™

ULTRA HEATWAVE™
TECHNOLOGY

The microwave system uses ULTRA HEATWAVE TECHNOLOGY™, which delivers a constant stream of microwave power—true high, medium and low power.

Typically, microwave ovens operate on HIGH power only. For example, to achieve a 50% power level ("medium") in a typical microwave oven, the microwave oven operates 50% of the time at HIGH power and 50% of the time OFF.

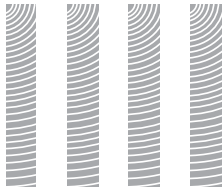

In contrast, microwave ovens utilizing ULTRA HEATWAVE TECHNOLOGY™ deliver the selected power level continuously. This constant stream of microwave power helps to minimize overcooking of foods and messy food spatters.



Sensor Cooking

The microwave system with ULTRA HEATWAVE TECHNOLOGY™ features sensor cooking functions. A humidity sensor in the microwave oven cavity detects moisture and humidity emitted from food as it heats. The sensor adjusts cooking times to various types and amounts of food. Sensor cooking takes the guesswork out of microwave cooking.

Grill Element



- A. Halogen bulb
- B. Quartz bulb

The microwave oven uses a 1,000-watt halogen bulb with a 500-watt quartz bulb to serve as the grill element for various cooking functions.

When the element is in use, the halogen bulb glows very brightly, while the glow of the quartz bulb is barely – if at all – visible. (See "Troubleshooting" for quartz bulb testing.) The microwave oven cavity and door will become hot. The use of oven mitts is recommended.

Convection Element and Fan

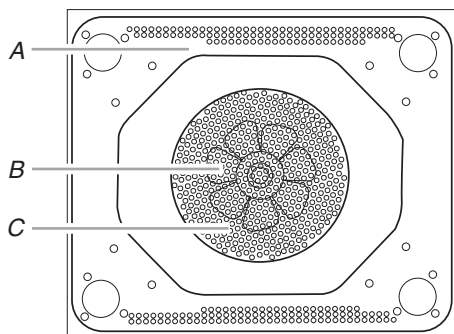

- A. Screen
- B. Convection fan (behind screen)
- C. Convection element (behind fan)

The microwave oven's convection system is composed of a convection element, which heats in conjunction with the convection fan for true convection cooking. The convection system is embedded in the wall of the microwave oven cavity, behind the screen. See "Parts and Features." The microwave oven cavity and door will become hot. The use of oven mitts is recommended.

Turntable

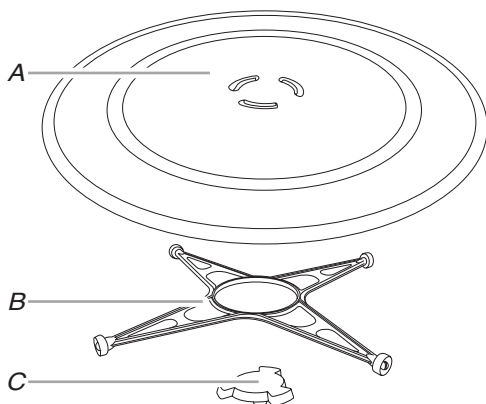

- A. Glass turntable
- B. Support
- C. Hub

The turntable can rotate in either direction to help cook food more evenly. For best cooking results, do not operate the microwave oven without having the turntable in place. To order any of the parts, call **1-800-4-MY-HOME®**. See "Replacement Parts" section for part numbers.

To Install:

1. Place the support on the microwave oven cavity bottom.
2. Place the turntable on the support.

Fit the raised, curved lines in the center of the turntable bottom between the three spokes of the hub. The rollers on the support should fit inside the turntable bottom ridge.

Turning Off the Turntable

The turntable can be turned off for manual cooking cycles only. This is helpful when cooking with plates that are larger than the turntable, or when cooking with two plates that are side by side. When the manual cycle is over, the turntable will automatically default to the "ON" mode.

To Turn On/Off:

1. Touch TURNTABLE (ON/OFF).

The display shows the Turntable On/Off screen.

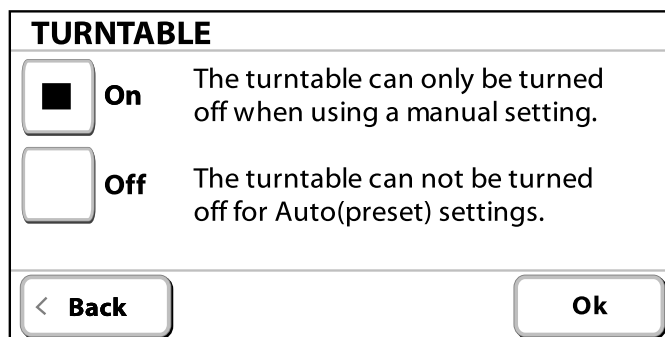

2. Select "Off," then touch "Ok."

The turntable off indicator will appear on the display.

Repeat to turn the turntable back on.

ACCESSORIES

The following accessories have been provided with your new microwave oven. Any of the parts may be ordered for replacement.

Steamer Vessel

Use the steamer vessel with the Steam Cook feature or Boil & Simmer feature to steam or simmer foods. See “Steam Cook” and/or “Boil & Simmer” sections.

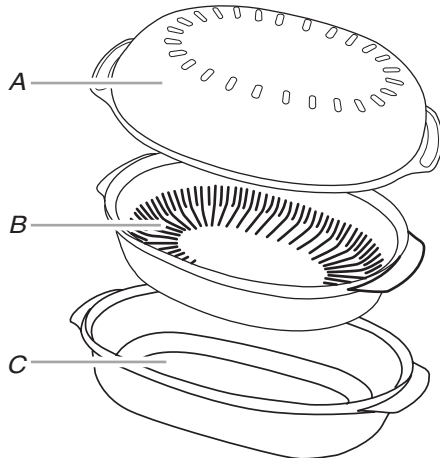

A. Lid
B. Insert
C. Base

- The steamer vessel will become hot. Always use oven mitts or pot holders when handling.
- To avoid damage to the steamer vessel, do not use in a conventional- or combination-type oven, with “Browning Pan” or “Grill” functions, any convection function or on electric or gas burners.
- To avoid scratching, use plastic utensils.
- Do not overfill. Using 1¼ cup (300 mL) of water in base is recommended.

Lid: Always use when cooking. Place directly over the insert and base or just the base.

Insert: Use when steam cooking to keep foods such as fish and vegetables out of water. Place insert with food directly over base. Do not use when simmering.

Base: For steam cooking, place water in base. For simmering foods such as rice, potatoes, pasta and vegetables, place food and water/liquid in base.

To order any of the parts, call **1-800-4-MY-HOME®**. See “Replacement Parts” section for part numbers. See “General Cleaning” section for cleaning instructions.

Browning Pan and Handle

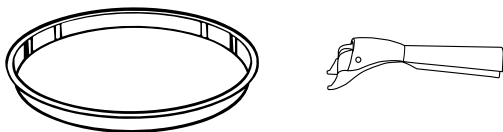

The browning pan, with its nonstick surface and detachable handle, has been specially designed for microwave use, and is ideal for pan-frying (pan-browning) foods in the microwave oven. See “Browning Pan” section. The browning pan is also ideal for some baking and roasting functions, and is used as a drip pan under the grill or convection racks during grilling or roasting cycles. See “Bake” and “Roast” sections.

Use the handle to grasp the pan. Place gripping end on the edge of pan, squeeze handle and lift pan. To order any of the parts, call **1-800-4-MY-HOME®**. See “Replacement Parts” section for part numbers.

Grill Rack

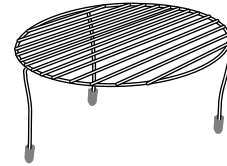

The tall grill rack is designed for grilling in the microwave oven. See “Grill” section. Place the grill rack securely on browning pan, the browning pan on the turntable, and position food on grill rack. To order any of the parts, call **1-800-4-MY-HOME®**. See “Replacement Parts” section for part numbers. See “General Cleaning” for cleaning instructions.

Convection Rack

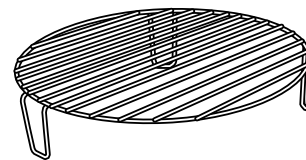

The short convection rack is designed to be used with the convection element and fan for true convection cooking. See “Bake” and “Roast” sections. Place the convection rack on the turntable, and position dish with food on the rack. If food is placed directly on the rack, the browning pan may be placed under the rack to catch drippings. To order any of the parts, call **1-800-4-MY-HOME®**. See “Replacement Parts” section for part numbers. See “General Cleaning” for cleaning instructions.

Rack and Pan Configurations

Browning Pan Feature

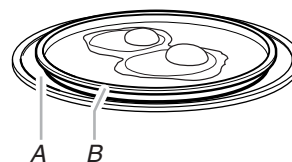

Grill Feature

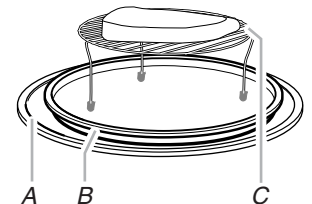

Roast Feature

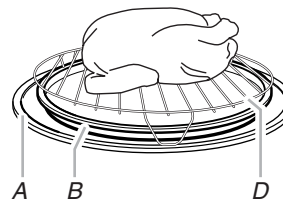

Bake Feature

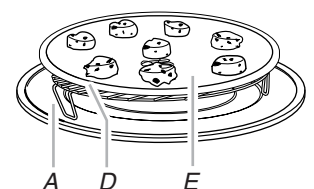

- A. Turntable
B. Browning pan
C. Grill rack (tall)
D. Convection rack (short)
E. Cookie sheet (not provided)

MICROWAVE OVEN CONTROL

The microwave oven's controls are accessed through its control panel and interactive touch display.

NOTE: Due to the sensitivity of the control panel, we have provided special instructions for cleaning the panel as well as the touch screen display. See "General Cleaning" section for cleaning instructions.

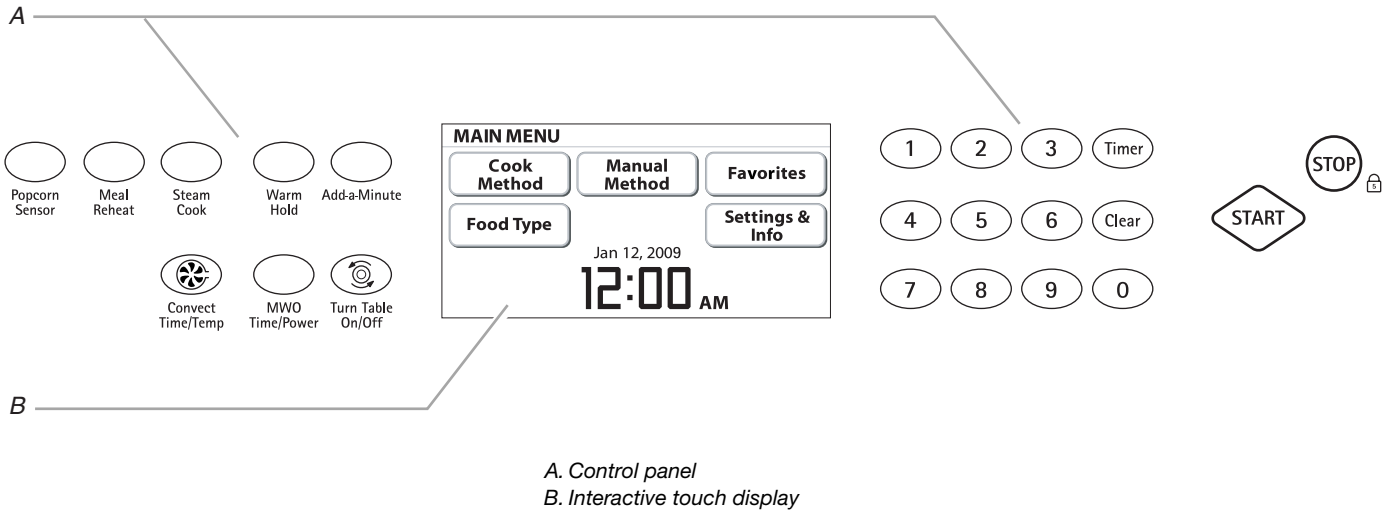

A. Control panel
B. Interactive touch display

Control Panel

The control panel houses basic controls and one-touch automatic function controls. The control pads are very sensitive, and require only a light touch to activate.

For more information about the individual controls, see their respective sections in this manual.

Interactive Touch Display

The display area functions as both a display and an interactive, menu-driven touch control. It is designed to be easily navigable, guiding you through the menus, offering multiple selections, accepting your input and executing your commands. It also provides instructions, tips, and graphics.

Display

When power is first supplied to the microwave oven, the welcome screen appears, asking whether you would like to set the clock. Touch "Yes" and set the clock (see "Clock" section), or touch "No" and the time will default to 12:00 p.m. If the welcome screen appears at any other time, a power failure has occurred. Reset the clock if needed.

When the microwave oven is not in use (in standby mode), the display shows the Main Menu and the date and time of day, if they are set to be displayed. See "Clock" and "Date" sections. After 2 minutes of inactivity, the display will go into sleep mode. See "Display Backlight" section.

During programming, the display shows menus, servings and weights, cooking time/power/temperature settings, preheating instructions, and/or cookware and preparation instructions.

During a cooking cycle, the display shows progress bar (sensor functions only, see "Progress Bar" section), cooking animation (see "Cooking Animation" section), and the countdown of cook time remaining. The display will also give prompts to tend to the food during certain automatic cycles.

Touch Screen

The LCD touch screen is used to make menu selections, adjust settings and input commands.

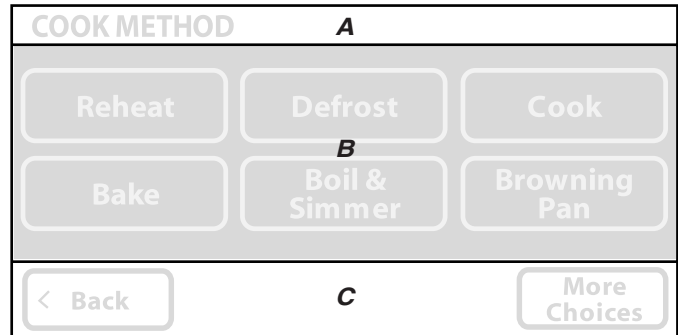

A. Title/description region
B. Menu and selection/settings input region
C. Command input region

Menu selections and input adjustments are made in the center portion of the screen, and the command inputs (start, continue, back, cancel, etc.) are made in the bottom portion of the screen. Screen titles and descriptions are displayed in the top portion of the screen, which accepts no input. A light- to medium-pressure touch of the fingertip will activate the menu choice.

Main Menu

The Main Menu is displayed on the default screen.

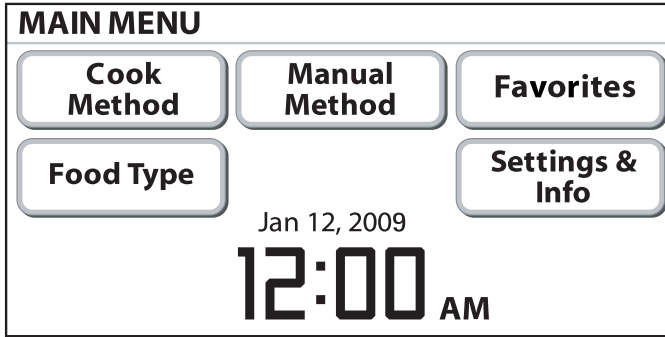

From the Main Menu, all automatic cooking programs can be activated; all manual cooking can be programmed; settings can be adjusted; and instructions, preparation and tips can be accessed.

The following demonstrates how to pan brown 2 boneless chicken breasts, using the Cook Method menus, starting from the Main Menu:

1. On Main Menu, touch "Cook Method."

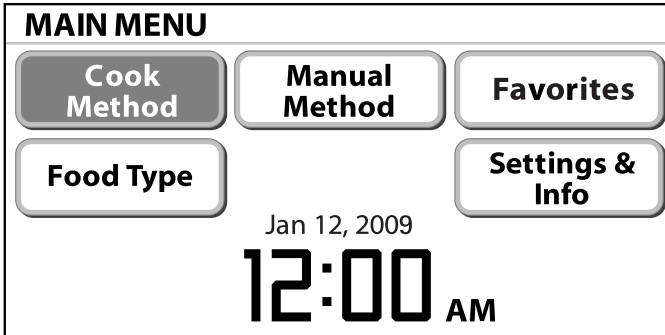

2. On Cook Method screen, touch "Browning Pan."

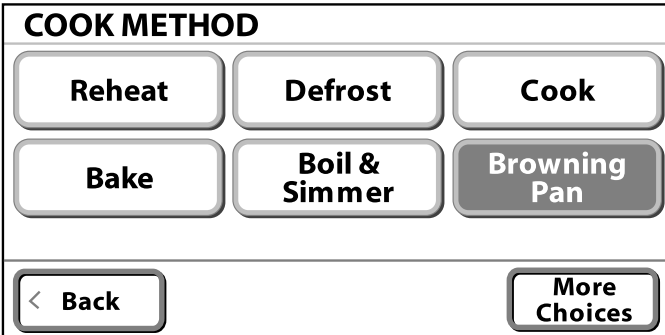

3. On Browning Pan screen, touch "More Choices."

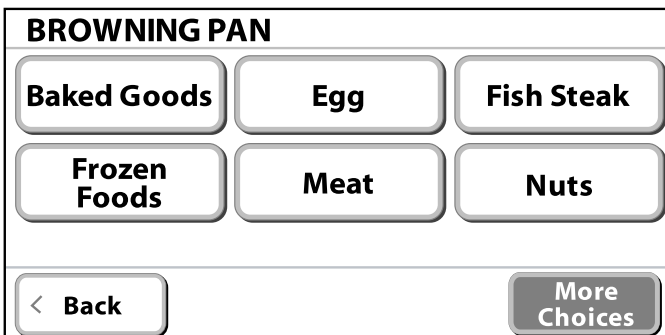

4. On next Browning Pan screen, touch "Poultry Brst Boneless."

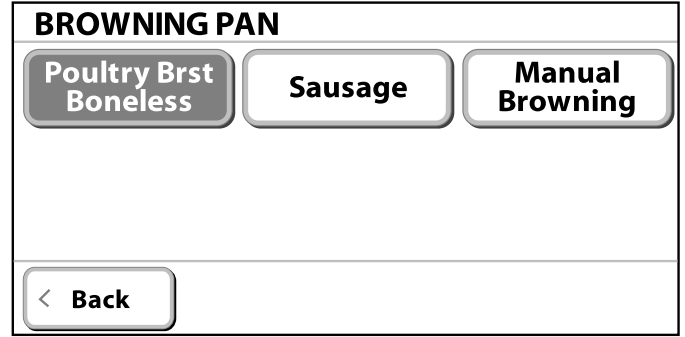

5. On Browning Pan-Poultry Breast screen, touch "2 pieces." Weight guidelines appear below the quantity selections.

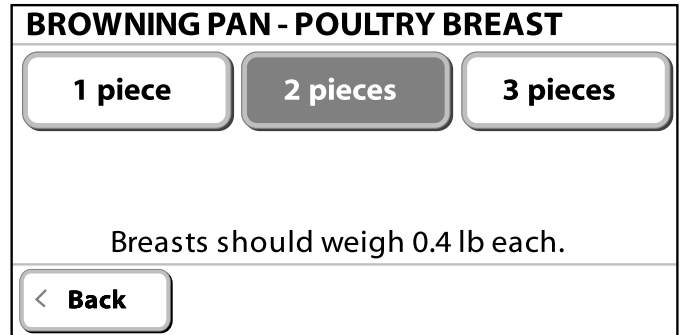

6. On Poultry Breast screen, follow the instructions, then touch "Start Preheat."

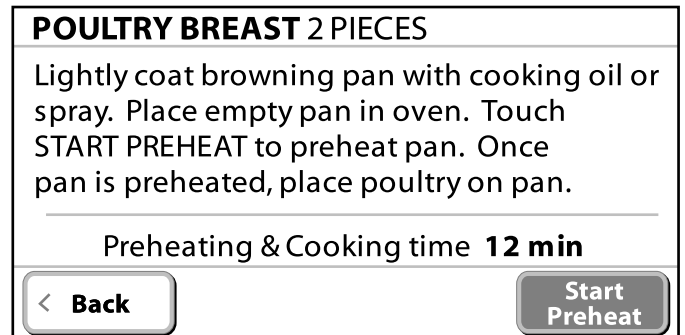

While the browning pan preheats, the cooking animation and countdown are active in the display.

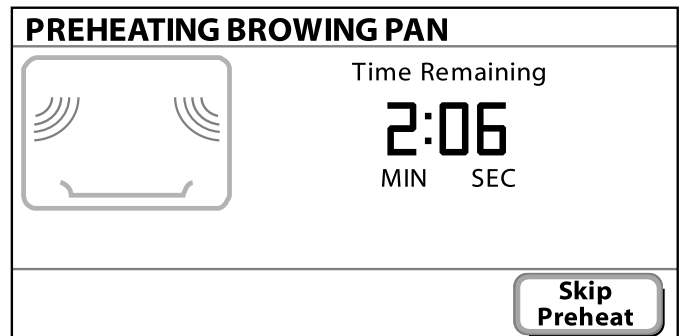

7. When preheating is finished, follow the instructions on the Preheat Finished screen, then touch “Continue.”
If more or less cook time is desired, adjust doneness before touching “Continue.”



While the poultry breasts are being pan browned, the cooking animation and countdown are active in the display.

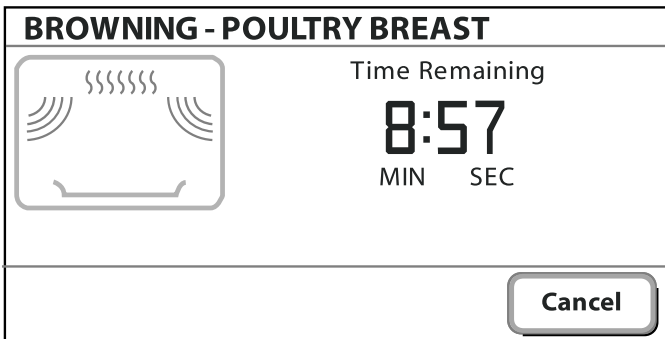

About halfway through the cycle, the microwave oven will stop, and the display will direct you to turn over the poultry breasts.

8. Touch “Continue” to resume pan browning.
When the cycle is over, the Finished screen appears.

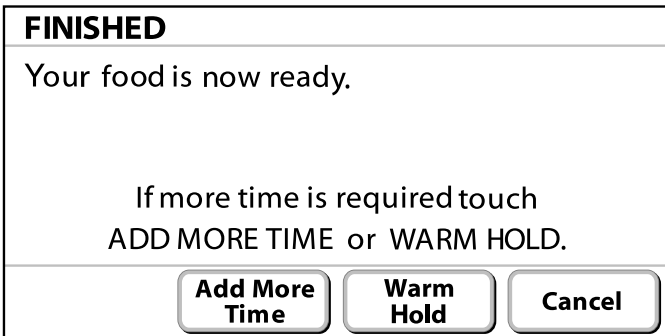

If you would like to either add more time or keep the food warm, you may do so at this time.

9. If the doneness is satisfactory, touch “Cancel” to return to the default screen.

The same cooking can also be accomplished using the “Food Type” menus instead of the “Cook Method” menu.

1. On Main Menu, touch “Food Type,” then “More Choices.”
2. Touch “Poultry,” then “More Choices.”
3. Touch “Poultry Breast: Pan Brown.”

This takes you to the same Browning Pan-Poultry Breast screen as in the Cook Method sequence.

4. Follow steps 4-8 in Cook Method sequence.

See “Learning Mode” section to see how to practice navigating through the menus without turning on the microwave generator.

Settings & Info

Microwave oven features may be activated and/or changed, and display characteristics may be adjusted using the “Settings & Info” menu. Following is a brief description of each option.

OPTION	SETTING
Clock	<ul style="list-style-type: none"> ■ Adjust time: set or hide clock. See “Clock” section.
Date	<ul style="list-style-type: none"> ■ Set date: month, day and year. ■ Hide date. See “Date” section.
Demo Mode	<ul style="list-style-type: none"> ■ View sales demonstration. See “Demo Mode” section.
Display Backlight	<ul style="list-style-type: none"> ■ Set backlight brightness: reduce after 2 minutes or turn off after 2 minutes. See “Display Backlight” section.
Display Contrast	<ul style="list-style-type: none"> ■ Set level of contrast between minimum and maximum using “+” and “-” controls. See “Display Contrast” section
Hints	View comprehensive lists of hints for general operation and care of microwave oven: <ul style="list-style-type: none"> ■ Cleaning: cavity, control panel, odors and turntable. ■ Cookware: covers, depth, materials and shape. ■ Convection Conversion: baking and roasting. ■ Food: eggs, moisture, quantity and shape. ■ Methods: arranging, covering, defrosting, standing and proofing dough. ■ Power levels: list of microwave power levels and sample foods for each.
Learning Mode	<ul style="list-style-type: none"> ■ Turn on or off. See “Learning Mode” section.
Volume	<ul style="list-style-type: none"> ■ Set tone volume using “+” and “-” controls. See “Tones” section.

1. On Main Menu, touch “Settings & Info.”
2. Touch desired option (touch “More Choices” for more categories), then follow the instructions on the screen to select and/or adjust settings.

Clock

This is a standard 12-hour clock (12:00 AM-11:59 PM). When power is first supplied to the microwave oven, or after a power failure, the “Welcome” screen will appear, asking whether you would like to set the clock. If you choose to set the clock at that time, the display will take you directly to the Clock screen. If you choose not to set the clock, the time of day will default to 12:00 p.m., and the clock will be displayed and continue to keep time.

To Set Clock:

1. On Main Menu, touch “Settings & Info.”
2. On Settings & Info screen, touch “Clock.”
3. On Clock screen, set the time of day and date, if desired, and select AM or PM.

To Hide Clock: On Clock screen, touch “Hide Clock.” The display will immediately return to the Main Menu.

Date

The date may be set and displayed on the Main Menu screen. The default setting is Jan. 1.

To Set Date:

1. On Main Menu, touch “Settings & Info.”
2. On Settings & Info screen, touch “Date.”
3. On Date screen, use number pads to set the month, day and year.

To Hide Date: On Date screen, touch “Hide Date.” The display will immediately return to the Main Menu. Repeat to display the date.

Demo Mode

The Demo Mode highlights the features and capabilities of the microwave oven in a slide show on the display.

To Activate Demo Mode:

1. On the Main Menu, touch “Settings & Info.”
 2. On Settings & Info screen, touch “Demo Mode.”
The demonstration immediately begins. You can move forward or back in the demonstration by touching “Next Page” or “Back,” or wait for the screen to advance. When the demonstration is over, it automatically loops back to the beginning and starts again.
 3. Touch “Cancel” on the touch screen, or touch STOP control to cancel Demo Mode and return the display to the Main Menu.
-

Display Backlight

Display backlight may be set to reduce brightness or to turn off during sleep mode.

Sleep mode is an energy-saving feature that darkens the display backlight after 2 minutes of inactivity. During sleep mode, only the time and date are visible, along with instruction to touch the display to reactivate the Main Menu.

To Set Display Backlight:

1. On Main Menu, touch “Settings & Info.”
2. Touch “Display Backlight.”
3. Select setting: reduce after 2 minutes or off after 2 minutes.
4. Touch “OK.”

Display Contrast

Display contrast has numerous settings, ranging from minimum to maximum.

To Set Display Contrast:

1. On Main Menu, touch “Settings & Info.”
 2. Touch “Display Contrast.”
 3. Using “+” and “-” controls, increase or decrease the contrast.
 4. Touch “OK.”
-

Learning Mode

The Learning Mode is ideal for learning how to use the microwave oven. When set, functions can be entered, with real displays and tones, without actually turning on the microwave generator (magnetron), grill element or convection element. While functions are operating in the Learning Mode, the microwave oven light will come on, the fan will run, and the turntable will rotate (if set ON).

While the Learning Mode is active, the Learn indicator is visible in the upper, right title area, or at the bottom command input area. The indicator is visible while the microwave oven is in standby mode, during programming, and during Settings & Info menu navigation. During a “practice” cooking cycle, the Learn indicator is visible in the lower, left command input area.

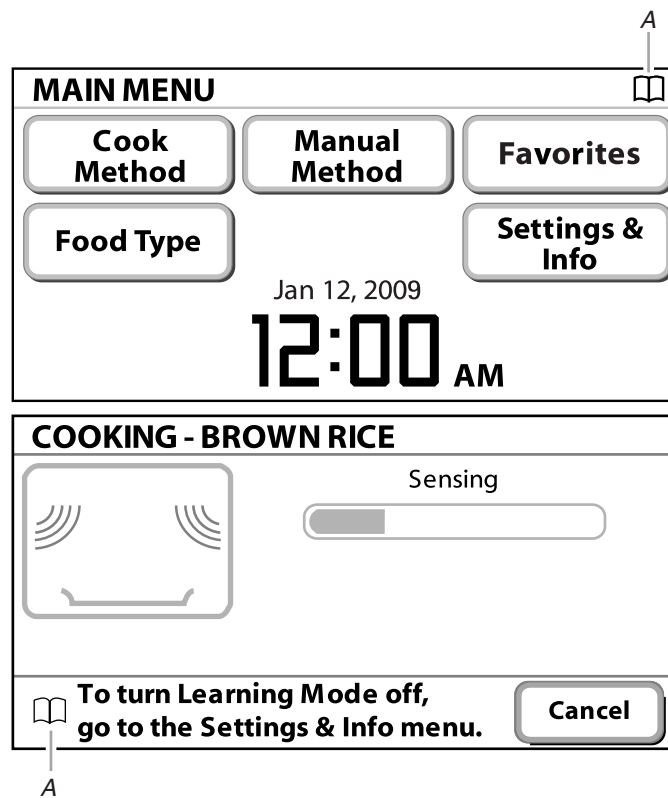

A. Indicators for Learning Mode

To Activate Learning Mode:

1. On the Main Menu, touch “Settings & Info.”
2. On Settings & Info screen, touch “More Choices.”
3. Touch “Learning Mode.”
4. Touch “On” or “Off” to set.
5. Touch “OK.”

Tones

Tones are audible signals, indicating the following:

One Tone

- Valid entry (short tone)

Two Tones

- Between stages (short tones)
- Reminder, repeat each minute for 10 minutes after the end-of-cycle tones
- End of Timer countdown
- Hidden feature entered or exited (very short, quick tones)

Three Tones

- Invalid entry (very short, quick tones)
- Retry Error

Four Tones

- End of cycle (2 short tones, followed by 2 longer tones)
- Interruption, tend to food (short tones)
- Attention - door needs to be opened and closed

To Adjust Tone Volume:

1. On Main Menu, touch “Settings & Info.”
2. On Settings & Info screen, touch “More Choices.”
3. Touch “Volume.”
4. Using “+” and “-” controls, increase or decrease the volume setting, or turn the tones off.
5. Touch “Ok.”

Start

The START control will start any function.

If non-sensor cooking is interrupted, touching the START control pad will resume the preset cycle.

If the microwave oven has not been in use and the door has not been opened in the past 5 minutes, the cooking function will not start. Open and close the door, then touch START to start or resume the cooking cycle.

For added convenience, the “Start” touch pad is also available on some display screens, and provides the same function as the START control pad.

Stop

The STOP control stops all functions except for the Timer and Learning Mode, and cancels programming in progress.

The microwave oven will also turn off when the door is opened. Close the door and touch START control or “Continue” on the touch screen to resume the cycle. A sensor cooking cycle may not be resumed if interrupted by opening the door.

Clear

During programming, the CLEAR control changes the numeric programming values, such as minutes, seconds and cook power that are active in the display to their default value. For example, while entering a cook time, touching CLEAR will change the time you have already entered to “0:00.” The CLEAR control gives an invalid signal (see “Tones” section) if touched during cooking.

Timer

The Timer can be set in minutes and seconds, up to 99 minutes, and counts down the set time.

NOTE: The Timer does not start or stop the microwave oven.

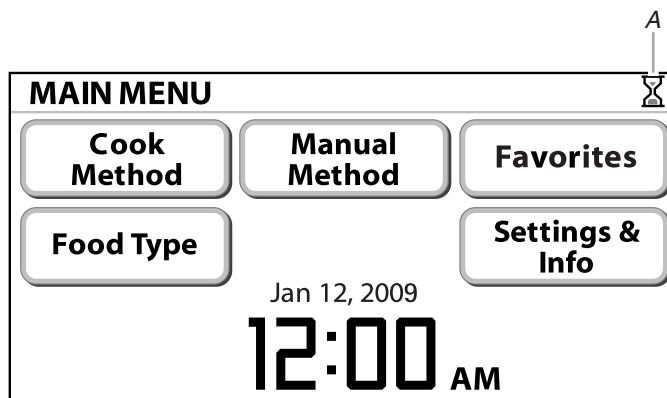

A. Timer indicator

While the Timer is in use, the microwave oven can still operate. During a microwave oven operation, the Timer countdown will be minimized. If the Timer ends while microwave oven is still operating, the end-of-Timer tones will sound, and the set operating mode will remain active on the screen.

To Set Timer:

1. Touch TIMER control.
2. Using the number pads, enter desired time in minutes and seconds, and then touch “Start Timer.”
The countdown will be in full screen view.
3. Touch “Ok” to minimize the timer.

To see the countdown in full screen view, touch TIMER control.

The time can be reset during the countdown by touching TIMER, entering a new time, then touching “Ok,” or the START control.

To Cancel: Touch TIMER control, then touch “Cancel Timer.”

Control Lock

The Control Lock disables all controls to avoid unintended use of the microwave oven. The only control that will function while the Control Lock is active is the STOP pad on the control panel.

Control Lock activation is possible only when the display is at the Main Menu.

To Activate Control Lock: Touch and hold STOP control for 5 seconds. Two tones will sound, and the display will show the padlock icon.

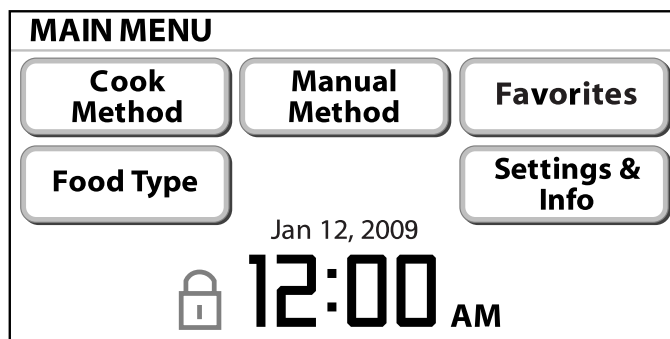

If any controls are touched while the Control Lock is active, the “Control Lock” reminder screen appears for 5 seconds.

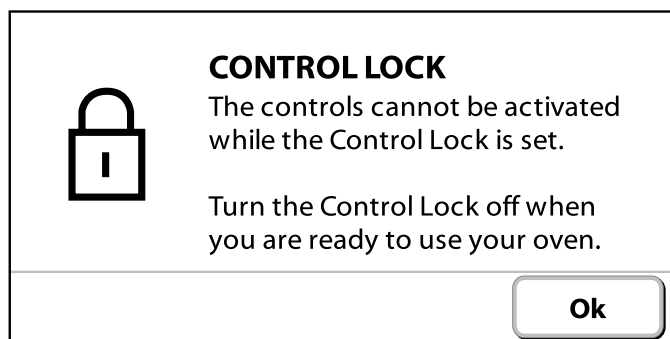

To Deactivate Control Lock: Touch and hold STOP control for 5 seconds. Two tones will sound, and the padlock icon will be removed from the display.

Vent Fan and Cooktop Lights



The microwave oven’s hood controls, on the left side of the control panel (see “Parts and Features”) operate the vent fan and cooktop lights.

Vent Fan

The vent fan has 3 regular speeds: high, medium and low. The vent fan also has a max speed, which is the highest speed.

To avoid damage to the microwave oven, the vent fan will automatically turn on at high speed if the temperature from the cooking surface below gets too hot. It may stay on for up to 1 hour to cool the microwave oven. When this occurs, the vent fan cannot be turned off. After the microwave oven has cooled, the vent fan will automatically turn off.

The vent fan will automatically turn on at low speed during convection or grill cooking, and may stay on for up to 10 minutes after the cycle has ended.

NOTE: For optimal vent system performance, turn on the vent fan before using the cooking surface below. This will maximize steam capture.

To Operate Vent Fan: Touch FAN control repeatedly to cycle through the settings: high, medium, low and off. Touch FAN EXHAUST control to turn on the max speed. The status will be displayed for a few seconds while the settings are being adjusted.

Cooktop Lights

The cooktop lights have 3 brightness settings: high, medium and low. The low setting may be appropriate for night light use.

To Turn Light On/Off: Touch LIGHT control repeatedly to cycle through the settings: high, medium, low and off. The status will be displayed for a few seconds while the settings are being adjusted.

Cooking Animation

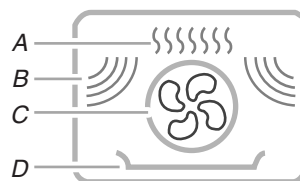

- A. Cooking with grill element
- B. Cooking with microwaves
- C. Cooking with convection
- D. Turntable icon

The cooking animation appears during any cooking cycle, whether automatic or manual. The animation shows what type of cooking is taking place.

Progress Bar

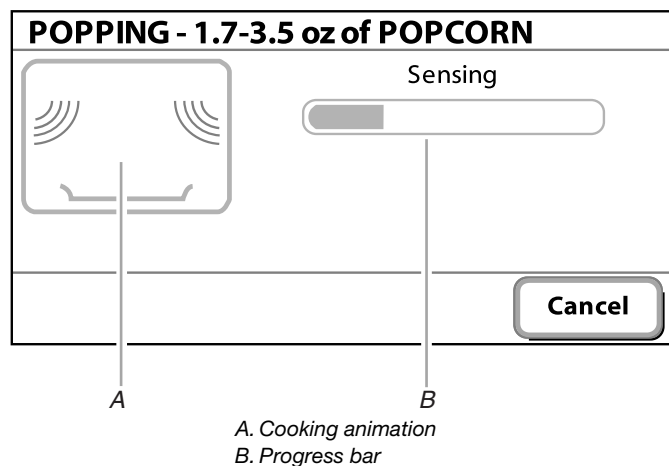

- A. Cooking animation
- B. Progress bar

The progress bar is a visual picture of the estimated running time of a sensor cooking cycle. It will appear at the beginning of sensor cooking functions. A horizontal bar appears below the word “Sensing,” and shows progress by the darkening of the bar left to right. Some time after the progress bar appears, it may be replaced by “Maximum Time Remaining” indicator and the estimated remaining time, which may fluctuate often. When sensing is finished, “Time Remaining” will appear with the actual remaining cook time.

The progress bar will also appear during microwave oven preheating.

MICROWAVE OVEN USE

A magnetron in the microwave oven produces microwaves which reflect off the metal floor, walls and ceiling and pass through the turntable and appropriate cookware to the food. Microwaves are attracted to and absorbed by fat, sugar and water molecules in the food, causing them to move, producing friction and heat which cooks the food.

- To avoid damage to the microwave oven, do not lean on or allow children to swing on the microwave oven door.
- To avoid damage to the microwave oven, do not operate microwave oven when it is empty.
- Baby bottles and baby food jars should not be heated in microwave oven.
- Clothes, flowers, fruit, herbs, wood, gourds, paper, including brown paper bags and newspaper, should not be dried in microwave oven.
- Paraffin wax will not melt in the microwave oven because it does not absorb microwaves.
- Use oven mitts or pot holders when removing containers from microwave oven.
- Do not overcook potatoes. At the end of the recommended cook time, potatoes should be slightly firm. Let potatoes stand for 5 minutes. They will finish cooking while standing.
- Do not cook or reheat whole eggs inside the shell. Steam buildup in whole eggs may cause them to burst, requiring significant cleanup of microwave oven cavity. Cover poached eggs and allow a standing time.

Food Characteristics

When microwave cooking, the amount, size and shape, starting temperature, composition and density of the food affect cooking results.

Amount of Food

The more food heated at once, the longer the cook time needed. Check for doneness and add small increments of time if necessary.

Size and Shape

Smaller pieces of food will cook more quickly than larger pieces, and uniformly shaped foods cook more evenly than irregularly shaped food.

Starting Temperature

Room temperature foods will heat faster than refrigerated foods, and refrigerated foods will heat faster than frozen foods.

Composition and Density

Foods high in fat and sugar will reach a higher temperature, and will heat faster than other foods. Heavy, dense foods, such as meat and potatoes, require a longer cook time than the same size of a light, porous food, such as cake.

Cooking Guidelines

Covering

Covering food helps retain moisture, shorten cook time and reduce spattering. Use the lid supplied with cookware. If a lid is not available, wax paper, paper towels or plastic wrap approved for microwave ovens may be used. Plastic wrap should be turned back at one corner to provide an opening to vent steam. Condensation on the door and cavity surfaces is normal during heavy cooking.

Stirring and Turning

Stirring and turning redistribute heat evenly to avoid overcooking the outer edges of food. Stir from outside to center. If possible, turn food over from bottom to top.

Arranging

If heating irregularly shaped or different sized foods, arrange the thinner parts and smaller sized items toward the center. If cooking several items of the same size and shape, place them in a ring pattern, leaving the center of the ring empty.

Piercing

Before heating, use a fork or small knife to pierce or prick foods that have a skin or membrane, such as potatoes, egg yolks, chicken livers, hot dogs, and sausage. Prick in several places to allow steam to vent.

Shielding

Use small, flat pieces of aluminum foil to shield the thin pieces of irregularly shaped foods, bones and foods such as chicken wings, leg tips and fish tail. See "Aluminum Foil and Metal" first.

Standing Time

Food will continue to cook by the natural conduction of heat even after the microwave cooking cycle ends. The length of standing time depends on the volume and density of the food.

Cookware and Dinnerware

Cookware and dinnerware must fit on the turntable. Always use oven mitts or pot holders when handling because any dish may become hot from heat transferred from the food. Do not use cookware and dinnerware with gold or silver trim. Use the following chart as a guide, then test before using.

MATERIAL	RECOMMENDATIONS
Aluminum Foil, Metal	See "Aluminum Foil and Metal" section.
Browning Dish	Bottom must be at least 3/16" (5 mm) above the turntable. Follow manufacturer's recommendations.
Ceramic Glass, Glass	Acceptable for use.
China, Earthenware	Follow manufacturer's recommendations.
Melamine	Follow manufacturer's recommendations.

MATERIAL	RECOMMENDATIONS
Paper: Towels, Dinnerware, Napkins	Use nonrecycled and those approved by the manufacturer for microwave oven use.
Plastic: Wraps, Bags, Covers, Dinnerware, Containers	Use those approved by the manufacturer for microwave oven use.
Pottery and Clay	Follow manufacturer's recommendations.
Silicone Bakeware	Follow manufacturer's recommendations.
Straw, Wicker, Wooden Containers	Do not use in microwave oven.
Wax Paper	Acceptable for use.

To Test Cookware or Dinnerware for Microwave Use:

- Place cookware or dinnerware in microwave oven with 1 cup (250 mL) of water beside it.
- Cook at 100% cooking power for 1 minute.

Do not use cookware or dinnerware if it becomes hot and the water stays cool.

Aluminum Foil and Metal

Always use oven mitts or pot holders when removing dishes from the microwave oven.

Aluminum foil and some metal can be used in the microwave oven. If not used properly, arcing (a blue flash of light) can occur and cause damage to the microwave oven.

OK for Use

Racks and bakeware supplied with the microwave oven (on some models), aluminum foil for shielding, and approved meat thermometers may be used with the following guidelines:

- To avoid damage to the microwave oven, do not allow aluminum foil or metal to touch the inside cavity walls, ceiling or floor.
- Always use the turntable.
- To avoid damage to the microwave oven, do not allow contact with another metal object during microwave cooking.

Do Not Use

Metal cookware and bakeware, gold, silver, pewter, non-approved meat thermometers, skewers, twist ties, foil liners such as sandwich wrappers, staples and objects with gold or silver trim or a metallic glaze should not be used in the microwave oven.

For Use with Convection System

Any ovenproof bakeware may be used during Manual Bake cycles, but only microwave-safe, ovenproof bakeware may be used for combination (microwaves + convection) cycles. Follow instructions on the display during convection programming.

- Use only ovenproof cookware for all convection (baking and roasting) cycles. See "Bake" and "Roast" sections.
- Do not use metal bakeware during stage cooking. See "Cooking in Stages" section.

- Do not use metal bakeware during combination cycles. Some automatic Cook, Bake and Roast programs use combination cooking. Follow instructions on the display during programming. Manual Roast may also be programmed for combination cooking.
- Use only microwave-safe, ovenproof cookware for all non-Bake convection or combination cycles.

For Use with Grill Element

Use only microwave-safe, ovenproof cookware, such as glass or ceramic glass, for automatic Grill and Manual Grill cycles.

- Do not place cookware on grill rack.
- Place cookware directly on the turntable. Cookware may be used under the grill rack to catch drippings.

Microwave Cooking Power

Many recipes for microwave cooking specify which cooking power to use by percent, name or number. For example, 70%=Medium-High.

Use the following chart as a general guide for the suggested cooking power of specific foods.

PERCENT/NAME	USE
100%, High (default setting)	Quick heating convenience foods and foods with high water content, such as soups, beverages and most vegetables.
90%	Cooking small tender pieces of meat, ground meat and poultry pieces. Heating cream soups.
80%	Heating rice, pasta or stirrable casseroles. Cooking and heating foods that need a cook power lower than high, such as meat loaf.
70%, Medium-High	Reheating a single serving of food. Cooking fish fillets.
60%	Cooking sensitive foods such as cheese and egg dishes, pudding and custards. Cooking non-stirrable casseroles, such as lasagna.
50%, Medium	Cooking ham, whole poultry, whole fish and pot roasts. Simmering stews.
40%	Heating bread, rolls and pastries.
30%, Medium-Low	Melting chocolate, butter and marshmallows.
20%	Defrosting bread, fish, meats, poultry and precooked foods. Softening ice cream, butter and cheese.
10%, Low	Taking chill out of fruit.

MANUAL COOKING

Add a Minute

The ADD-A-MINUTE control automatically starts the microwave oven at 100% power for 1 minute, and adds 1 minute of cook time, up to 10 minutes, with each additional touch of the control. Time may be added in 1-minute increments by touching ADD-A-MINUTE, or by minutes and seconds using the interactive touch screen display. Cook power or cook time may be changed after cooking begins by using the “Adjust Settings” control. While settings are being adjusted, the countdown freezes, and then resumes when adjustments are made.

MWO Time/Power Cooking

The MWO TIME/POWER control is for manual microwave-only cooking.

To Use MWO TIME/POWER:

1. Place food on the turntable, and close the door.
2. Touch MWO TIME/POWER control pad.
3. Use number pads to enter the cook time in minutes and seconds.
If using 100% cooking power, skip Step 3.
4. Touch “Cook Power: 100%,” and then use number pads to adjust the power level, between 10% and 100%.
5. Touch “Start” on the touch screen, or START control.
The display will count down the cook time.
During the countdown, cook time and/or cooking power may be changed by touching “Adjust Settings” on the touch screen, and following the prompts.
When the cycle ends, the end-of-cycle tones will sound, followed by reminder tones.
6. Touch STOP control or open the door to stop reminder tones. The display will return to the Main Menu after STOP control is touched.

Convect Time/Temp Cooking

The CONVECT TIME/TEMP control is for manual convection or combination cooking.

The cook time may be set in hours and minutes. The temperature may be set from 100°F (38°C) to 450°F (232°C) in 5-degree increments.

NOTE: The microwave cooking power may be set to 0%, 10%, 20% or 30%. The default power is 0%.

To Use:

1. Place food on the turntable, and close the door.
2. Touch CONVECT TIME/TEMP control.
3. Use number pads to enter the cook time in hours and minutes.
4. Touch “Temp: 350°,” and then use number pads to enter temperature, if cooking at a temperature other than the default 350°F (177°C).
5. For microwave-assisted convection cooking, enter power level (10%-30%). Default power is 0%.
6. Touch “Start Preheat” on the touch screen to preheat empty microwave oven. If preheat is not needed, touch “Skip Preheat” after the microwave oven starts.
The display will count down the cook time.
During the countdown, cook time, temperature and/or cooking power may be changed by touching “Adjust Settings” on the touch screen, and adjusting the remaining time and/or the cooking power.
When the cycle ends, the end-of-cycle tones will sound, followed by reminder tones.
7. Touch STOP control or open the door to stop reminder tones. The display will return to the Main Menu after STOP control is touched.

Manual Method Cooking

The Manual Method control on the Main Menu is for manual cooking by cooking method. There are 12 methods from which to choose. Some of the methods have set power levels that cannot be changed. Use the following chart as a guide.

METHOD	COOK WITH	COOKWARE	POWER/TEMP SETTINGS
Reheat	Microwaves only	Microwave-safe	10-100%; 100% default
Defrost	Microwaves only	Microwave-safe	20% only
Cook	Microwaves only	Microwave-safe	10-100%; 100% default
Bake	Convection only	Ovenproof, convection rack	100°F (38°C)-450°F (232°C); 350°F (177°C) default
Grill	Grill and microwaves	Ovenproof, microwave-safe, grill rack, Browning Pan	0-40%; 0% default
Melt	Microwaves only	Microwave-safe	30% only
Roast	Convection, microwaves	Ovenproof, microwave-safe, convection rack, Browning Pan	225°F (107°C)-450°F (232°C); 325°F (163°C) default 0-30%; 0% default
Boil & Simmer	Microwaves only	Microwave-safe; Steamer Vessel	Enter desired time.
Browning Pan	Microwaves only	Browning Pan	80% only
Soften	Microwaves only	Microwave-safe	20% only
Steam Cook	Microwaves only	Microwave-safe; Steamer Vessel	Enter desired time.
Keep Warm	Microwaves only	Microwave-safe	10% only

To Use:

1. Place food on the turntable, and close the door.
2. Touch “Manual Method” on the Main Menu.
3. Select a method from the chart.
4. Follow instructions on the display to program cooking time, temperature and/or cooking power.

5. Touch “Start” on the touch screen, or START control.

The display will count down the cook time.

During the countdown, cook time and some cooking powers and/or temperatures may be changed by touching “Adjust Settings” on the touch screen, and adjusting the remaining time, cooking power and/or temperature.

When the cycle ends, the end-of-cycle tones will sound, followed by reminder tones.

6. Touch STOP control or open the door to stop reminder tones. The display will return to the Main Menu after STOP control is touched.

Cooking in Stages (or steps)

Manual cooking may be done in stages (or steps), up to 4 stages total. The first stage may be programmed using any of the manual controls. The stages may be reviewed at any time during programming and/or cooking by touching “Review Steps” on the touch screen.

Convection cooking cannot be done in stages.

NOTE: Manual Defrost can be programmed only as the 1st stage, and is not available for subsequent stage programming.

To Cook in Stages:

1. Follow steps 1-4 in “MWO Time/Power Cooking,”
or
follow steps 1-4 in “Manual Method Cooking.”
2. Touch “Add A Step” on the touch screen.
3. Select cook method, and follow screen prompts to program the next stage.
4. Repeat steps 2 and 3 to program each additional stage.
5. Touch “Start” on the touch screen, or START control.

The display will show the cycling stage’s cook time and cooking power, and will count down each stage in turn.

During the countdown, cook time and/or cooking power for the cycling stage may be changed by touching “Adjust Settings” on the touch screen, and following the prompts.

Each stage will immediately follow the previous stage, and between cycle tones will sound when each new stage begins.

When the cycle ends, the end-of-cycle tones will sound, followed by reminder tones.

6. Touch STOP control or open the door to stop reminder tones. The display will return to the Main Menu after STOP control is touched.

Raising (Proofing) Bread

This microwave oven can be used to proof bread using the convection system.

First Proofing:

Place dough in a lightly greased ovenproof bowl, and cover loosely with shortening-coated wax paper.

1. Place a shallow, ovenproof container, such as a pie plate, filled with 2 cups (500 mL) boiling water on the turntable.
2. Place the convection rack on the turntable, and then place the bowl of dough on the convection rack and close the door.
3. Touch “Manual Method” on the Main Menu, then select “Bake.”
4. Follow instructions on the display to program the proofing time (about 45 minutes).
5. Touch “Temp 350°,” and then set a temperature of 100°F (38°C) using the number pads.
6. Touch “Start Preheat,” and then touch “Skip Preheat.”
7. Touch “Start” on the touch screen, or START control.
The display will count down the proofing (baking) time.

Check dough after 20 to 25 minutes. Let dough rise until nearly doubled in size. Proofing time may vary depending on the type and quantity of dough. Proofing time may be changed during the countdown by touching “Adjust Settings,” and then following the instructions on the display.

When the cycle ends, the end-of-cycle tones will sound, followed by reminder tones.

When proofing is done, remove bowl of bread dough and water container.

8. Touch STOP to return the display to the Main Menu.

Second Proofing:

Shape dough, place in baking pan(s), and then cover loosely with plastic wrap sprayed with cooking spray.

1. Place ovenproof container filled with 2 cups (500 mL) boiling water on the turntable.
2. Place bread pan(s) on the convection rack and close the door.
3. Follow steps 3 through 7 outlined in “First Proofing.”

When proofing is done, remove the bread dough and water container.

Reset microwave oven to preheat for baking bread. Before baking, remove plastic wrap from bread dough.

Warm Hold

WARNING

Food Poisoning Hazard

Do not let food sit in oven more than one hour before or after cooking.

Doing so can result in food poisoning or sickness.

Hot cooked food can be kept warm in the microwave oven. The Warm Hold function uses 10% cook power. Warm Hold can be used by itself, or it can be programmed to follow a cooking cycle.

- Cover plates of food.
- Cover foods that were covered while being cooked.
- For best results, do not cover baked goods such as pastries, pies, turnovers, etc.

To Use:

1. Place hot cooked food on the turntable, and close the door.
2. Touch Warm Hold control.
3. Adjust warm time, if desired.
4. Touch “Start” on the touch screen, or START control.

The display will count down the warm time.

During the countdown, warm time may be changed by touching “Adjust Settings” on the touch screen, and adjusting the remaining time.

When the cycle ends, the end-of-cycle tones will sound, followed by reminder tones.

5. Touch STOP control or open the door to stop reminder tones and return to the Main Menu.

PROGRAMMED COOKING

Convection Cooking

During convection cycles, the convection element heats the air in the microwave oven cavity, and the convection fan circulates the hot air. The constantly moving air surrounds the food to heat the outer portion quickly.

See “Food Type Chart” for automatic convection cycles (Bake or Roast).

Convection cooking may also be done manually. Use convection cooking for items such as pies, breads, cookies, cakes and pizza. See “Manual Cooking” section for instructions.

Manual convection cooking may be used to proof bread. See “Raising (Proofing) Bread” section for instructions.

NOTES:

- Use the provided convection rack.
- Do not cover the turntable or convection rack with foil, as it interferes with the circulation of hot air.
- Do not use light plastic containers, plastic wrap or paper products. All ovenproof cookware or metal utensils can be used in convection cooking. (Round pizza pans are excellent cooking utensils for many convection-only items.) Metal utensils cannot be used in microwave or combination cooking.
- No special techniques are needed to adapt standard oven recipes to convection cooking, although some cooking times might need to be shortened, and some temperatures adjusted.
- This microwave oven may be preheated in the same way that a standard oven is preheated. (Most recipes for baked goods call for preheating.)

Combination Cooking

Combination cooking uses microwaves in addition to the convection system to cook or roast foods more quickly than with convection alone.

Combination cooking may also be done manually. Use combination cooking for items such as roasts, meat loaf, lasagna, casseroles and whole chicken. See “Manual Method Cooking” or “Convect Time/Temp” sections for instructions.

NOTES:

- Do not use metal cookware or utensils during combination cooking.
- Meats may be roasted directly on the convection rack. Use the browning pan to catch drippings.
- Less tender cuts of beef can be roasted and tenderized using oven cooking bags.
- Check for doneness after the cycle has ended. If the food is not completely done, let it stand in the microwave oven for a few minutes to finish cooking.
- During any automatic or manual combination cycle, no more than 30% microwave power is used.

Sensor Cooking

Some automatic cycles are sensor cycles. See “Cook Method Chart.” No amounts need to be entered. A sensor in the microwave oven detects humidity released from the food as it heats, and adjusts the cook time accordingly. The progress bar appears during sensing (see “Progress Bar” section).

Many sensor cycles require the covering of foods. The provided steamer vessel has a loose-fitting lid, which allows enough steam to escape to be detected by the sensor. When covering foods with plastic wrap, be sure to leave a large enough vent opening to allow the steam to escape.

NOTES:

- The microwave oven should be plugged in for at least 2 minutes.
- The microwave oven cavity and the exterior of the cooking container should be dry.
- The room temperature should not exceed 95°F (35°C).
- If the door is opened during a sensor cycle, sensing will stop and the program will be canceled.
- For optimal performance, wait at least 30 minutes after convection cooking or grill cooking before sensor cooking.

Preheating

Preheating of the microwave oven is programmed in some automatic convection cycles. After the microwave oven is preheated, it will maintain the set preheat temperature until the door is opened to add food. Preheating may be skipped after it has started by touching “Skip Preheat” on the touch screen, adding food, and then touching “Continue.”

Preheating of the browning pan is programmed in many automatic cooking cycles. This preheating phase may also be skipped by touching “Skip Preheat.”

For optimal results, we recommend completing the preheating phase of each cycle in which preheating is programmed. However, preheating of the microwave oven would not be necessary when baking consecutive batches, such as cookies, as the microwave oven would already be hot.

Doneness

Doneness for food items may be adjusted for most automatic cycles. Before starting a cycle, touch “Doneness” on the touch screen, and adjust the doneness with “+” (more done) or “-” (less done) controls. The “+” control adds to, and the “-” control subtracts from the recommended default cook time.

The more done and less done settings in most foods for which doneness may be adjusted are equal. That is, the same amount of time may be added to or subtracted from the cycle. Some of the Meat and Poultry cycles have only the more done settings.

Popcorn Sensor

Popcorn is a sensor function. The sensor determines the appropriate popping time of commercially packaged microwavable popcorn.

The sensor will determine accurate popping times for bag sizes: 3.5 oz (99 g), 3.0 oz (85 g) or 1.75 oz (50 g). For bag sizes not listed in this section, follow directions on the package.

NOTE: During Popcorn function, as with all microwave cooking functions, the microwave oven should be attended at all times. Listen for popping to slow to 1 pop every 1 or 2 seconds, then stop the cycle.

- For best results, do not place bag on convection rack or grill rack.
- To avoid damage to the microwave oven, do not use regular paper bags or glassware.
- Pop only 1 package of popcorn at a time.
- Follow manufacturer's instructions when using a microwave popcorn popper.
- For best cooking results, do not try to pop unpopped kernels.
- Use fresh bags of popcorn for optimal results.
- Cooking results may vary by brand and fat content.

To Use Popcorn Sensor:

1. Place popcorn bag on the turntable and close the door.
2. Touch POPCORN SENSOR control.

The microwave oven will start automatically. The display will show when the microwave oven is sensing, and will start counting down the time when sensing has finished.

When the cycle ends, the end-of-cycle tones will sound, followed by reminder tones.

3. Touch STOP control or open the door to stop reminder tones. The display will return to the Main Menu after STOP control is touched.

Using Food Type

The Food Type menu has 12 methods from which to choose.

Breakfast Food	Dairy/Dessert	Frozen Food
Liquids	Snacks	Vegetable
Bread	Casserole	Fish/Seafood
Grains (Pasta/Rice)	Meat	Poultry

This menu allows you to choose what specific food item you want to cook, and then choose how you would like to cook it, if there is more than 1 cook method available. All cook methods and foods are available through this menu.

See "Food Type Chart" in this manual, or review your Quick Reference Guide for all of the food items and programmed cycles.

See "Main Menu" section for an example of how using the Food Type menu works.

To Use: Place food on the turntable, and close the door. Touch "Food Type" on Main Menu, select your food category, and then follow the screen prompts to select your specific food item and cook method, and to start the cycle.

Using Cook Method

The Cook Method menu has 11 methods from which to choose.

Reheat	Defrost	Cook
Bake	Boil & Simmer	Browning Pan
Grill	Melt	Roast
Soften	Steam Cook	

This menu allows you to start with the type of cooking you want, and then choose your specific food item. All food items are available through this menu.

See each method's respective section in this manual for method details.

See "Cook Method Chart" for all of the programmed cycles.

See "Main Menu" section for an example of how using the Cook Method menu works.

To Use: Place food on the turntable, and close the door. Touch "Cook Method" on Main Menu, select your desired method, and then follow the screen prompts to select your food item and to start the cycle.

Reheat

The Reheat menu has a selection of main food categories, plus a shortcut to Manual Reheat (see "Manual Method Cooking" section).

Beverage	Casserole Leftover	Meal
Muffin	Pizza Leftover	Roll
Sauce	Soup	Manual Reheat

Reheat uses only microwaves to heat the food.

See "Cook Method Chart" for food item details, such as specific food items available, sensor functions and amounts.

To Use: Place food on the turntable, and close the door. Touch "Cook Method" on Main Menu, touch "Reheat," and then follow screen prompts to make your selections, prepare your food and/or microwave oven for reheating, and start the cycle.

Defrost

The Defrost menu has a selection of main food categories, plus a shortcut to Manual Defrost (see “Manual Method Cooking” section).

Bread	Fish/Seafood	Meat
Poultry	Manual Defrost	

Defrost uses only microwaves to defrost the food.

Defrost should not be used for food left out of the freezer for more than 20 minutes, or for frozen ready-made food.

- Food should be 0°F (-18°C) or colder at the time the cycle is started for optimal results. How foods are stored can affect results.
- Unwrap foods and remove lids (for example, from fruit juice containers) before defrosting.
- Shallow packages will defrost more quickly than thick blocks.
- Separate food pieces as soon as possible during or at the end of the cycle for more even defrosting.
- Use small pieces of aluminum foil to shield parts of food such as chicken wings, leg tips and fish tails. See “Aluminum Foil and Metal” first.

See “Cook Method Chart” for specific food items and amounts.

To Use: Place food on the turntable, and close the door. Touch “Cook Method” on Main Menu, touch “Defrost,” and then follow screen prompts to make your selections, and to start the cycle.

Defrost programs are set by the weight of the food item in pounds and/or ounces. If the weight is not known, touch “Weight Unknown” on the touch screen, and follow the prompts.

Preparation instructions for each food item will be displayed while you are programming the cycle.

Cook

The Cook menu has a selection of main food categories, plus a shortcut to manual Cook (see “Manual Method Cooking” section).

Casserole	Cereal/Oatmeal	Couscous
Egg	Fish/Seafood	Frozen Food
Instant Mac & Cheese	Meat	Pasta
Poultry	Rice	Vegetable
Manual Cook		

Cook may use microwaves, convection system and/or grill elements, as well as special cookware for various programs.

See “Cook Method Chart” for food item details, such as sensor functions, convection functions and amounts.

To Use: Place food on the turntable, and close the door. Touch “Cook Method” on Main Menu, touch “Cook,” and then follow screen prompts to make your selections, prepare your food and/or microwave oven for cooking, and start the cycle.

Bake

The Bake menu has a selection of main food categories, plus a shortcut to Manual Bake (see “Manual Method Cooking” section).

Angel Food Cake	Biscuit, Refrigerated	Bread
Brownies	Cookies	Muffin
Pie	Pot Pie	Quiche
Roll, Refrigerated	Soufflé	Manual Bake

Bake may use the convection system with or without microwaves to bake your food.

See “Cook Method Chart” for specific food items and amounts.

You will need to use your provided convection rack. Ovenproof, microwave-safe bakeware may be used during any of the Bake cycles. The screen prompts give instruction for each food item, and its appropriate bakeware. See “Cookware and Dinnerware” section.

- The microwave oven cavity and door will become hot during the Bake cycle. The use of oven mitts is recommended.
- The convection rack and any cookware or bakeware will become very hot. Use oven mitts to remove the hot rack and cookware from the microwave oven to a heat-safe surface.
- While the convection system is in use, the cooling fan turns on and stays on for up to 10 minutes after the cycle is over.

To Use: Place food on the turntable, and close the door. Touch “Cook Method” on Main Menu, touch “Bake,” and then follow screen prompts to make your selections, prepare your food and/or microwave oven for baking, and start the cycle.

After Baking

The food, convection rack, microwave oven cavity and door will be very hot. The microwave oven’s cooling fan will stay on until the microwave oven cools.

Boil & Simmer

The Boil & Simmer menu has a selection of main food categories, plus a shortcut to Manual Boil & Simmer (see “Manual Method Cooking” section).

Couscous	Dried Pasta	Fresh Pasta
Rice	Manual Boil & Simmer	

Boil & Simmer is a sensor function, and uses only microwaves to simmer your food.

See “Cook Method Chart” for specific food items and amounts.

- Follow recommended water and food amounts that appear on the display.
- Use the provided steamer vessel base and lid, or a microwave-safe dish with a loose-fitting lid.
- For best results, do not use plastic wrap as a cover during the Boil & Simmer cycle.
- Do not remove the lid while the dish is still in the microwave oven, as the rush of steam will disrupt the sensor readings.

To Use: Place food on the turntable, and close the door. Touch “Cook Method” on Main Menu, touch “Boil & Simmer,” and then follow screen prompts to make your selections, prepare your food for simmering, and start the cycle.

Simmering Pasta

The water will need to boil before adding the pasta. Place the dish of water, covered, in the microwave oven and begin the cycle. When the water boils, the microwave oven will stop and prompt you to add the pasta. If manually simmering, place the covered dish of water in the microwave oven, and set a simmer time of 1 second. The water will start to boil, the 1-second simmer time will end, and the microwave oven will stop.

Using oven mitts, gently remove the covered dish of boiling water, add the pasta, re-cover, place the dish back in the microwave oven and continue the cycle.

Simmering Rice

Place food and water/liquid, covered, in the microwave oven and begin the cycle. The sensor determines when the water starts to boil, and figures the simmer time, which will begin counting down in the display.

Browning Pan

The Browning Pan menu has a selection of main food categories, plus a shortcut to Manual Browning Pan (see “Manual Method Cooking” section).

Baked Goods	Egg	Fish Steak
Frozen Food	Meat	Nuts
Poultry Breast Boneless	Sausage	Manual Browning Pan

Browning Pan function uses microwaves, and sometimes the grill element. Microwaves quickly heat the pan, while the grill element browns (or crisps) the food from above.

Some Browning Pan cycles are programmed to preheat the empty pan for 3 minutes before cooking begins. When the preheating cycle is complete, the microwave oven will stop and prompt you to add the food to the browning pan. The microwave oven may prompt you to turn over the food during the cycle.

See “Cook Method Chart” for specific food items and amounts.

- Microwave oven cavity and door will become very hot during the Browning Pan cycle. The use of oven mitts is recommended.
- The browning pan will become very hot. Use oven mitts to grasp and remove the pan from the microwave oven. To avoid damage, do not place hot browning pan directly on heat-sensitive surfaces.
- Use detachable handle when handling hot browning pan.
- Do not use plastic utensils on the browning pan, as it becomes very hot quickly and could melt the utensils.
- To avoid scratching the browning pan, do not use metal utensils.
- To avoid damage to the browning pan, do not use in any other microwave oven or in a standard thermal oven.
- Do not place the browning pan on the grill rack or the convection rack. Always use the turntable as a support for the pan.
- For best results, coat the browning pan lightly with cooking oil to make removing food and cleaning the pan easier.
- When the grill element is in use, the cooling fan turns on and stays on for up to 10 minutes after the cycle is over.

To Use: Place food on the turntable, and close the door. Touch “Cook Method” on Main Menu, touch “Browning Pan,” and then follow screen prompts to make your selections, prepare the food and/or browning pan for cooking, and start the cycle.

Grill

The Grill menu has a selection of main food categories, plus a shortcut to Manual Grill (see “Manual Method Cooking” section).

Beef Kabobs	Chicken, Bone-In	Fish Steak
Hamburger Patty	Pork Chops	Shrimp
Steak	Vegetable	Manual Grill

Grill uses the grill element and microwaves to grill your food.

See “Cook Method Chart” for specific food items and amounts.

- Microwave oven cavity and door will become very hot during the Grill cycle. The use of oven mitts is recommended.
- The grill rack and browning pan will become very hot. Use oven mitts to grasp and remove the pan from the microwave oven. To avoid damage, do not place hot browning pan directly on heat-sensitive surfaces.
- Use the grill rack to place food closer to the grill element for faster grilling.
- Use the browning pan to catch drippings. Do not place the browning pan on the grill rack.
- Place grill rack securely on browning pan, and place both on the turntable. Then position food directly on rack.
- The turntable must be turned on when using the grill rack.
- For best results, apply light amount of cooking oil to grill rack.
- When the grill element is in use, the cooling fan turns on and stays on for up to 10 minutes after the cycle is over.

To Use: Place food on the turntable, and close the door. Touch “Cook Method” on Main Menu, touch “More Choices,” and then “Grill.” Follow screen prompts to make your selections, prepare your food for grilling, and start the cycle.

After Grilling

The food, grill rack, browning pan, microwave oven cavity and door will be very hot. Using oven mitts, grasp the browning pan securely with both hands, and remove it with the grill rack and food still in place to a heat-safe surface.

When handling the hot browning pan, use the detachable handle.

The microwave oven’s cooling fan will stay on until the microwave oven is cooled.

Melt

The Melt menu has a selection of main food categories, plus a shortcut to Manual Melt (see “Manual Method Cooking” section).

Butter/Margarine	Caramel	Cheese
Chocolate	Marshmallow	Manual Melt

Melt uses only microwaves to melt your food.

See “Cook Method Chart” for specific food items and amounts.

To Use: Place food on the turntable, and close the door. Touch “Cook Method” on Main Menu, touch “More Choices,” and then “Melt.” Follow screen prompts to make your selections, prepare your food and/or microwave oven for cooking, and start the cycle.

Roast

The Roast menu has a selection of main food categories, plus a shortcut to Manual Roast (see “Manual Method Cooking” section).

Beef Roast	Cornish Hen	Pork Chops
Pork Roast	Shrimp	Steak
Turkey Breast, Bone-In	Whole Chicken	Manual Roast

Roast uses microwaves and the convection system to roast your food.

See “Cook Method Chart” for specific food items and amounts.

- The microwave oven cavity and door will become hot during the Roast cycle. The use of oven mitts is recommended.
- The convection rack and browning pan will become very hot. Use oven mitts to remove the hot rack and browning pan from the microwave oven. To avoid damage, do not place hot browning pan directly on heat-sensitive surfaces.
- Do not use metal cookware during the Roast cycle.
- Use the provided convection rack and browning pan.
- Place the browning pan under the convection rack to catch the drippings.
- While the convection system is in use, the cooling fan turns on and stays on for up to 10 minutes after the cycle is over.

To Use: Place food on the turntable, and close the door. Touch “Cook Method” on Main Menu, touch “More Choices,” and then touch “Roast.” Follow screen prompts to make your selections, prepare your food and/or microwave oven for roasting, and start the cycle.

After Roasting

The food, convection rack, browning pan, microwave oven cavity and door will be very hot. Using oven mitts, grasp the browning pan securely with both hands, and remove it with the convection rack and food still in place to a heat-safe surface.

When handling the hot browning pan, use the detachable handle.

The microwave oven’s cooling fan will stay on until the microwave oven is cooled.

Soften

The Soften menu has a selection of main food categories, plus a shortcut to Manual Soften (see “Manual Method Cooking” section).

Brown Sugar	Butter/Margarine	Caramel Dip
Cream Cheese	Frozen Juice	Ice Cream
Manual Soften		

Soften uses only microwaves to soften your food.

See “Cook Method Chart” for specific food items and amounts.

To Use: Place food on the turntable, and close the door. Touch “Cook Method” on Main Menu, touch “More Choices,” and then “Soften.” Follow screen prompts to make your selections, prepare your food and/or microwave oven for cooking, and start the cycle.

Steam Cook

The Steam Cook menu has a selection of main food categories, plus a shortcut to Manual Steam Cook (see “Manual Method Cooking” section).

Fish Fillet	Fresh Vegetable	Frozen Vegetable
Shrimp	Manual Steam	

Steam Cook is a sensor function, and uses only microwaves to steam your food.

See “Cook Method Chart” for specific food items and amounts.

- Use the provided steamer vessel and its lid. Place 1¼ cups (300 mL) water in the base, place food in the insert, place the insert in the base and cover.
- Do not remove the lid while the vessel is inside the microwave oven, as the rush of steam will disrupt the sensor readings.
- The steamer vessel will become hot. Always use oven mitts or pot holders when handling.
- To avoid scratching, use plastic utensils.
- Do not overfill. One-half full is recommended.
- Follow directions on the display.

To Use: Place food on the turntable, and close the door. Touch “Cook Method” on Main Menu, touch “More Choices,” and then “Steam Cook.” Follow screen prompts to make your selections, prepare the food for steaming, and start the cycle.

Favorites Menu

The Favorites menu displays the 6 most used automatic cooking programs. This provides you with your own customized menu, which is easily accessible from the Main Menu.

The programs are shown in order of frequency of use. The food type is shown first on the selection pad, followed on the next line by the cook method. Following is the default Favorites menu screen:

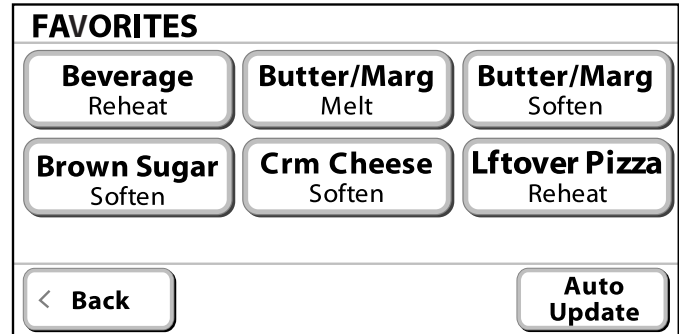

To Update Favorites Menu: On the Favorites screen, touch “Auto Update.” The microwave oven shows the 6 programs used most frequently since the last time the menu was updated.

Food Type Chart

Use this chart as a reference for menu items available in the "Food Type" menu

BREAKFAST FOOD

<p>Bacon Cook</p> <p>Cereal Instant Cook</p> <p>Egg Fried - Cook or Browning Pan Omelet - Cook or Browning Pan Poached - Cook Scrambled - Cook</p>	<p>Grits Quick - Cook Regular - Cook</p> <p>Hash Brown Cook or Browning Pan</p> <p>Hot Wheat Cook</p> <p>Muffin Fresh - Bake, Browning Pan or Reheat Frozen - Defrost or Reheat</p>	<p>Oatmeal Instant - Cook Regular - Cook</p> <p>Quiche Bake</p> <p>Sausage Cook or Browning Pan</p> <p>Soufflé Bake</p>
-----------------------------------------------------------------------------------------------------------------------------------------------------------------------------------------------------------------	---------------------------------------------------------------------------------------------------------------------------------------------------------------------------------------------------------------------------------------------------------	---------------------------------------------------------------------------------------------------------------------------------------------------------------------------------

DAIRY/DESSERT

<p>Angel Food Cake Bake</p> <p>Brown Sugar Soften</p> <p>Brownies Bake or Browning Pan</p> <p>Butter/Margarine Melt or Soften</p> <p>Caramel Melt</p> <p>Caramel Dip Soften</p>	<p>Cheese Melt</p> <p>Chocolate Melt</p> <p>Cookies Bake or Browning Pan</p> <p>Cream Cheese Soften</p> <p>Ice Cream Soften</p>	<p>Marshmallows Melt</p> <p>Nuts Browning Pan</p> <p>Pie Fresh - Bake Frozen - Bake</p> <p>Soufflé Bake</p>
---------------------------------------------------------------------------------------------------------------------------------------------------------------------------------------------------------------------------------------------------	----------------------------------------------------------------------------------------------------------------------------------------------------------------------------------------	---------------------------------------------------------------------------------------------------------------------------------------------------------------------

FROZEN FOOD

<p>Frozen Entrée Regular (8-20 oz [227-567 g]) - Cook Large (40 oz [1.1 kg]) - Cook Family Size (60 oz [1.7 kg]) - Cook</p> <p>Fish Fillet, Breaded - Cook Fillet, Non-breaded - Defrost or Cook Fish Stick - Cook</p> <p>French Toast Cook or Browning Pan</p>	<p>Garlic Bread Bake</p> <p>Hash Brown Cook or Browning Pan</p> <p>Pie Bake</p> <p>Pizza Kids Pizza 5" - Cook Pizza Roll - Cook Rising Crust - Cook or Browning Pan Thin Crust - Cook or Browning Pan</p>	<p>Pot Pie Bake</p> <p>Poultry Defrost</p> <p>Soup Reheat</p> <p>Vegetable Cook or Steam Cook</p>
------------------------------------------------------------------------------------------------------------------------------------------------------------------------------------------------------------------------------------------------------------------------------------------------------------------------------------------	-----------------------------------------------------------------------------------------------------------------------------------------------------------------------------------------------------------------------------------------------------------------------------------	-----------------------------------------------------------------------------------------------------------------------------------------------

LIQUIDS

<p>Beverage Reheat</p> <p>Frozen Juice Soften</p> <p>Soup, Frozen Reheat</p>	<p>Sauce Thick - Reheat Thin - Reheat</p>	<p>Soup, Thick Reheat</p> <p>Soup, Thin Reheat</p>
---------------------------------------------------------------------------------------------------------------	------------------------------------------------------------------	--------------------------------------------------------------------------

SNACKS

Burrito
Cook
Cheese Sticks
Cook
French Fries
Browning Pan
Instant Macaroni & Cheese
Cook

Kids Pizza 5"
Cook
Marshmallow
Melt
Pizza, Leftover
Reheat

Pizza Roll
Cook
Potato Nuggets
Browning Pan
Snack Pocket
Cook

VEGETABLE

Canned Vegetable
Cook
Fresh Vegetable
Asparagus
- Cook or Steam Cook
Broccoli
- Cook or Steam Cook
Carrots
- Cook or Steam Cook
Cauliflower
- Cook or Steam Cook

Fresh Vegetable (cont'd)
Corn on the Cob
- Cook or Steam Cook
Green Beans
- Cook or Steam Cook
Mushroom
- Cook or Grill
Onion
- Grill
Pepper
- Grill

Fresh Vegetable (cont'd)
Potato Baked/Sweet
- Cook
Red Potato, New
- Steam Cook
Spinach
- Cook or Steam Cook
Summer Squash/Zucchini
- Cook or Steam Cook
Tomato
- Grill
Frozen Vegetable
Cook or Steam Cook

BREAD

Bagel
Small
- Defrost
Medium
- Defrost
Large
- Defrost
Biscuit, Refrigerated
Large
- Bake or Browning Pan
Regular
- Bake or Browning Pan

French Toast
Cook or Browning Pan
Loaf Bread
Frozen
- Defrost
Garlic Bread
- Bake
Quick
- Defrost or Bake
Yeast
- Defrost or Bake

Muffin
Fresh
- Reheat, Bake or Browning Pan
Frozen
- Reheat or Defrost
Roll
Fresh/Leftover
- Reheat
Frozen
- Reheat, Defrost or Bake
Large, Refrigerated
- Bake
Regular, Refrigerated
- Bake

CASSEROLE

Lasagna
Cook
Leftover Casserole
Reheat

Pasta Casserole
Cook
Potato Casserole
Cook

Vegetable Casserole
Cook

FISH/SEAFOOD

Fish Fillet
Fresh
- Cook or Steam Cook
Frozen, Breaded
- Cook
Frozen, Non-Breaded
- Defrost or Cook

Fish Steak
Defrost, Cook or Grill
Fish Stick, Frozen
Cook

Scallops
Defrost
Shrimp
Defrost, Grill, Roast or Steam Cook

GRAINS: PASTA/RICE

Canned Pasta

Cook

Couscous

Boil & Simmer

Grits

Quick

- Cook

Regular

- Cook

Instant Macaroni & Cheese

Cook

Pasta

Dried Pasta

- Fettuccine

Cook

- Macaroni

Cook

Pasta

Dried Pasta (cont'd)

- Penne

Cook

- Rotini

Cook

- Spaghetti

Cook

Fresh Pasta

- Linguine

Cook

- Ravioli

Cook

- Tortellini

Cook

Rice

Brown Rice Instant

Cook

Brown Rice Long Grain

Cook

White Rice Instant

Cook

White Rice Long Grain

Cook

White Rice Short Grain

Cook

MEAT

Beef

Beef Kabobs

- Grill

Ground Beef

- Defrost or Cook

Hamburger Patty

- Cook or Grill

Meat Loaf

- Cook

Roast Beef

- Roast

Steak

Defrost, Grill or Roast

Hot Dog

Cook

Lamb Chops

Defrost, Roast or Grill

Meatballs

Cook or Browning Pan

Pork

Bacon

- Cook

Ham Slice

- Cook

Pork (cont'd)

Ham Steak

- Cook

Pork Chops

- Defrost, Grill or Roast

Pork Roast

- Roast

Sausage

Browning Pan

POULTRY

Cornish Hen

Roast

Chicken Nuggets

Cook

Chicken, Bone-In

Defrost, Cook or Grill

Chicken, Boneless

Defrost or Cook

Chicken Tenders

Cook

Chicken Wings

Cook

Ground Poultry

Defrost or Cook

Poultry Breast, Pan Brown

Browning Pan

Poultry Breast, Poached

Cook

Turkey Breast, Bone-In

Roast

Whole Chicken

Roast

Cook Method Chart

Use this chart as a reference for menu items and amounts available in the "Cook Method" menu.

REHEAT

Beverage

1 or 2 cups (250-500 mL)

Casserole, Leftover

1-4 cups (250 mL-1 L)

Meal (dinner plate)

1 meal (sensor)

2 meals

Muffin

Fresh: 1-6 muffins

Frozen: 1-6 muffins

Pizza Leftover

1-3 slices

Roll

Fresh: 1-6 rolls

Frozen: 1-6 rolls

Sauce

Thick: senses 1-4 cups (250 mL-1 L)

Thin: senses 1-4 cups (250 mL-1 L)

Soup

Frozen: 1-4 cups (250 mL-1 L)

Thick: senses 1-4 cups (250 mL-1 L)

Thin: senses 1-4 cups (250 mL-1 L)

Manual Reheat

DEFROST

Bread

- 0.1-2.0 lbs (45-900 g)
Weight Unknown
- Bagel
 - small: 2-8 bagels
 - medium: 1-6 bagels
 - large: 1-6 bagels
 - Muffin
 - small: 4, 6, 8, 10, 12, 14 or 16 muffins
 - medium: 1-6 muffins
 - large: 1-6 muffins
 - Roll
 - small: 2-7 rolls
 - medium: 1-6 rolls
 - large: 1-6 rolls

Fish/Seafood

- 0.1-4.5 lbs (45 g-2.0 kg)
Weight Unknown
- Fillet: 1-6 pieces
 - Shrimp: 1-4 cups (250 mL-1 L)
 - Scallops: 1-4 cups (250 mL-1 L)
 - Steak: 1-4 pieces

Meat

- 0.1-6.5 lbs (45 g-2.9 kg)
Weight Unknown
- Chops
 - small: 1-6 pieces
 - medium: 1-6 pieces
 - large: 1-4 pieces
 - Ground: 1, 2, 3 or 4 cups (250, 500, 750 mL or 1 L)
 - Steak
 - small: 1-6 pieces
 - medium: 1-4 pieces
 - large: 1 or 2 pieces

Poultry

- 0.1-6.5 lbs (45 g-2.9 kg)
Weight Unknown
- Breast: 1-6 pieces
 - Ground: 1, 2, 3 or 4 cups (250, 500, 750 mL or 1 L)
 - Pieces
 - small: 1-6 pieces
 - medium: 1-4 pieces
 - large: 1-4 pieces

Manual Defrost

COOK

Casserole

- Pasta Casserole: 1.5 or 2.0 qt (1.4 or 1.9 L)
Potato Casserole: 1.5 or 2.0 qt (1.4 or 1.9 L)
Vegetable Casserole: 1.5 or 2.0 qt (1.4 or 1.9 L)

Cereal/Oatmeal

- Grits
- Quick: senses 1-4 servings
 - Regular: senses 1-4 servings
- Hot Wheat: 1-4 servings
Instant Cereal: 1-4 servings
Oatmeal
- Instant: 1-4 servings
 - Regular: 1-4 servings

Couscous

- senses 1-4 servings

Egg

- Fried: 1-4 eggs
Omelet: 2-4 eggs
Poached: 1-4 eggs
Scrambled: 1-4 eggs

Fish/Seafood

- Fish Fillet
- Fresh: senses 0.5-2.0 lbs (227-907 g)
 - Frozen, Breaded: 1-4 servings
 - Frozen, Non-breaded: 1-6 pieces
- Fish Steak: 0.5-1.0 lb (227-454 g)
Fish Stick, Frozen: 1-4 servings (6-18 sticks)

Frozen Food

- Burrito: 1 or 2 burritos
Cheese Sticks: 1-4 servings
Fish/Seafood
- Fish Fillet, Breaded: 1-4 servings
 - Fish Fillet, Non-Breaded: 1-6 pieces
 - Fish Stick: 1-4 servings (6-18 pieces)
- French Fries: 1-3 servings
French Toast: 1-4 pieces
Frozen Entrée
- Regular: senses 8-20 oz (227-567 g)
 - Large: 40 oz (1.1 kg)
 - Family: 60 oz (1.7 kg)

Frozen Food (cont'd)

- Frozen Pizza
- Kids Pizza 5"
 - Pizza Roll: 1-4 servings
 - Rising Crust: 6" - 12" (15.2-30.5 cm)
 - Thin Crust: 6" - 12" (15.2-30.5 cm)
- Frozen Vegetable: senses 2-6 cups (500 mL-1.5 L)
Hash Brown: 1-4 patties
Snack Pocket: 1 or 2 servings
- ### Meat
- Bacon: 2-4 slices
Ground Beef: 0.5, 1.0, 1.5 or 2.0 lbs (227, 454, 680 or 907 g)
Ham Slice: 1-4 slices
Ham Steak: 4-8 oz (113-227 g)
Hamburger Patty: 1-4 patties
Hot Dog: 1-4 hot dogs
Meat Loaf: 1.0, 1.5 or 2.0 lbs (454, 680 or 907 g)
Meatballs: 0.5 or 1.0 lb (227 or 454 g)
Sausage: 2-10 links

Pasta

- Canned Pasta: senses 1-4 servings
Dried Pasta
- Fettuccine: senses 2-8 oz (57-227 g)
 - Macaroni: senses 0.5-2.0 cups (125-500 mL)
 - Penne: senses 0.5-2.0 cups (125-500 mL)
 - Rotini: senses 0.5-2.0 cups (125-500 mL)
 - Spaghetti: senses 2-8 oz (57-227 g)
- Fresh Pasta
- Linguine: senses 9 or 18 oz (255 or 510 g)
 - Ravioli: senses 9 or 18 oz (255 or 510 g)
 - Tortellini: senses 9 or 18 oz (255 or 510 g)
- Instant Mac & Cheese: 1-2 servings
Lasagna: 8" x 8" (22.9 x 33.0 cm) or 9" x 13" (20.3 x 33.0 cm)
Pasta Casserole: 1.5 or 2.0 qt (1.4 or 1.9 L)

COOK (cont'd)

Poultry

- Chicken Nuggets: 1-4 servings (4-16 pieces)
- Chicken
 - Bone-In: 0.5-3.5 lbs (227 g-1.5 kg)
 - Boneless: 0.2-2.0 lbs (90-907 g)
- Chicken Tenders: 1-4 servings
- Chicken Wings: 1-4 servings
- Ground Poultry: 0.5, 1.0, 1.5 or 2.0 lbs (227, 454, 680 or 907 g)
- Poultry Breast Boneless
 - Pan Brown: 1-3 pieces
 - Poached: 0.2-1.5 lbs (90-680 g)

Rice

- Brown Rice Instant: senses 0.5-2.0 cups (125-500 mL)
- Brown Rice Long Grain: senses 0.5-2.0 cups (125-500 mL)
- White Rice Instant: senses 0.5-2.0 cups (125-500 mL)
- White Rice Long Grain: senses 0.5-2.0 cups (125-500 mL)
- White Rice Short Grain: senses 0.5-2.0 cups (125-500 mL)

Vegetable

- Canned Vegetable: 8-32 oz (237-946 mL)
- Fresh Vegetable
 - Asparagus: senses 8-16 oz (227-454 g)
 - Broccoli: senses 1-6 cups (250 mL-1.5 L)
 - Carrots: senses 1-6 cups (250 mL-1.5 L)
 - Cauliflower: senses 1-6 cups (250 mL-1.5 L)
 - Corn on the Cob: senses 1-4 ears
 - Green Beans: senses 1-6 cups (250 mL-1.5 L)
 - Mushroom: senses 1-6 cups (250 mL-1.5 L)
 - Potato, Baked/Sweet: senses 1-4 potatoes
 - Spinach: senses 2-6 cups (500 mL-1.5 L)
 - Summer Squash/Zucchini: senses 1-6 cups (250 mL-1.5 L)
- Frozen Vegetable: senses 2-6 cups (500 mL-1.5 L)
- Vegetable Casserole: 1.5-2.0 qt (1.4-1.9 L)

Manual Cook

BAKE

Angel Food Cake

- 1 cake

Biscuit, Refrigerated

- Large: 5 or 8 biscuits
- Regular: 5 or 10 biscuits

Bread

- Garlic Bread: 8-10 oz (227-283 g) loaf
- Quick: 1 or 2 loaves
- Yeast: 1 or 2 loaves

Brownies

- 8" x 8" (20.3 x 20.3 cm) or 9" x 13" (22.9 x 33.0 cm)

Cookies

- 1 cookie sheet

Muffin

- 6 or 12 muffins

Pie

- Fresh: 9" (22.9 cm)
- Frozen: 9" (22.9 cm)

Pot Pie

- 1 or 2 pies

Quiche

- 9" (22.9 cm)

Roll, Refrigerated

- Large: 5 or 6 rolls
- Regular: 4 or 8 rolls

Soufflé

- 1 soufflé (2.0 qt [1.9 L])

Manual Bake

BOIL & SIMMER

Couscous

- senses 1-4 servings

Dried Pasta

- Fettuccine: senses 2-8 oz (57-227 g)
- Macaroni: senses 0.5-2.0 cups (125-500 mL)
- Penne: senses 0.5-2.0 cups (125-500 mL)
- Rotini: senses 0.5-2.0 cups (125-500 mL)
- Spaghetti: senses 2-8 oz (57-227 g)

Fresh Pasta

- Linguine: senses 9 or 18 oz (255 or 510 g)
- Ravioli: senses 9 or 18 oz (255 or 510 g)
- Tortellini: senses 9 or 18 oz (255 or 510 g)

Rice

- Brown Rice Instant: senses 0.5-2.0 cups (125-500 mL)
- Brown Rice Long Grain: senses 0.5-2.0 cups (125-500 mL)
- White Rice Instant: senses 0.5-2.0 cups (125-500 mL)
- White Rice Long Grain: senses 0.5-2.0 cups (125-500 mL)
- White Rice Short Grain: senses 0.5-2.0 cups (125-500 mL)

Manual Boil & Simmer

BROWNING PAN

Baked Goods

- Biscuit
 - Large: 5 or 8 biscuits
 - Regular: 5 or 10 biscuits
- Brownies: 20 oz (567 g) package
- Cookies: 4, 6 or 8 cookies
- Muffins: 4, 6 or 8 muffins
- Roll, Refrigerated
 - Large: 5 or 6 rolls
 - Regular: 4 or 8 rolls

Egg

- Fried: 1-4 eggs
- Omelet: 2-4 eggs

Fish Steak

- 0.5-1.0 lb (227-454 g)

Frozen Food

- Cheese Sticks: 1-4 servings
- Chicken Nuggets: 1-4 servings (4-16 pieces)
- Chicken Tenders: 1-4 servings
- Fish
 - Fillet, Frozen, Breaded: 1-4 servings
 - Fish Stick Frozen: 1-4 servings (6-18 pieces)
- French Fries: 1-3 servings
- French Toast: 1-4 pieces
- Hash Brown: 1-4 patties
- Pizza
 - Rising Crust: 6"-11" (15.2-27.9 cm)
 - Roll: 1-4 servings
 - Thin Crust: 6"-12" (15.2-30.5 cm)
- Potato Nuggets: 1-4 servings
- Sausage: 2-10 links

BROWNING PAN (cont'd)

Meat Bacon: 2-4 slices Ham Slice: 1-4 slices Ham Steak: 4-8 oz (113-227 g) Hamburger Patty: 1-4 patties, 0.3 lb (136 g) each Meatballs: 0.5-1.0 lbs (227-454 g)	Nuts 0.5, 1.0, 1.5 or 2 cups (125, 250, 375 or 500 mL) Poultry Breast, Boneless 1-3 pieces, 0.4 lb (113 g) each Sausage 2-10 links Manual Browning Pan
---------------------------------------------------------------------------------------------------------------------------------------------------------------------------------------	------------------------------------------------------------------------------------------------------------------------------------------------------------------------------------------------------

GRILL

Beef Kabobs 1-4 servings Chicken, Bone-In 1 or 2 pieces, 0.8 lb (363 g) each Fish Steak 1 or 2 steaks, 1" (2.4 cm) thick Hamburger Patty 1-4 patties Pork Chops 1 or 2 chops	Shrimp 5-8 oz (142-227 g) Steak 1 steak, 0.7-1.0 lb (318-454 g), 1/2" (13 mm) thick Vegetable Mushroom: 1-3 servings; 5-6, 10-12 or 15-18 pieces Onion: 1 or 2 servings, 5-6 or 10-12 pieces Pepper: 1 or 2 servings, 1 or 2 halves Summer Squash: 1 or 2 servings Tomato: 2 or 4 halves Manual Grill
--------------------------------------------------------------------------------------------------------------------------------------------------------------------------------------------------------------------------------------------	-----------------------------------------------------------------------------------------------------------------------------------------------------------------------------------------------------------------------------------------------------------------------------------------------------------------------------------------------------------------

MELT

Butter/Margarine 0.5, 1.0, 1.5 or 2 sticks or 1-8 tbs (15-120 mL) Caramel 7 or 14 oz (199 or 397 g) Cheese 8 or 16 oz (227 or 454 g)	Chocolate 1-12 oz (28-340 g) or 0.5, 1.0, 1.5 or 2.0 cups (125, 250, 375 or 500 mL) Marshmallow 5 or 10 oz (142 or 283 g) Manual Melt
--------------------------------------------------------------------------------------------------------------------------------------------------------------------------	------------------------------------------------------------------------------------------------------------------------------------------------------------------------

ROAST

Beef Roast 2.0-5.0 lbs (907 g-2.3 kg) Cornish Hen 1.0-2.5 lbs (454 g-1.1 kg) Pork Chops 1 or 2 chops Pork Roast 2.0-5.0 lbs (907 g-2.3 kg)	Shrimp 5-8 oz (142-227 g) Steak 1 steak, 0.7-1.0 lb (318-454 g), 1/2" (13 mm) thick Turkey Breast, Bone-In 3.0-6.0 lbs (1.4-2.7 kg) Whole Chicken 2.5-6.0 lbs (1.1-2.7 kg) Manual Roast
---------------------------------------------------------------------------------------------------------------------------------------------------------------------------------------------	----------------------------------------------------------------------------------------------------------------------------------------------------------------------------------------------------------------------------------------------------

SOFTEN

Brown Sugar 0.5, 1.0, 1.5 or 2.0 cups (125, 250, 375 or 500 mL) Butter/Margarine 0.5, 1.0, 1.5 or 2 sticks or 1-8 tbs (15-120 mL) Cream Cheese 3 or 8 oz (85 or 227 g)	Frozen Juice 6, 12 or 16 oz (170, 340 or 454 g) Ice Cream 16, 32 or 64 oz (473, 946 mL or 1.9 L) Manual Soften
------------------------------------------------------------------------------------------------------------------------------------------------------------------------------------------------------------	-------------------------------------------------------------------------------------------------------------------------------------------------

STEAM COOK

Fish Fillet senses 0.5-2.0 lbs (227-907 g) Fresh Vegetable Asparagus: senses 8-16 oz (227-454 g) Broccoli: senses 2-6 cups (500 mL-1.5 L) Carrots: senses 2-6 cups (500 mL-1.5 L) Cauliflower: senses 2-6 cups (500 mL-1.5 L) Corn on the Cob: senses 2-4 ears Green Beans: senses 2-6 cups (500 mL-1.5 L)	Fresh Vegetable (cont'd) Red Potato, New: senses 2-6 cups (500 mL-1.5 L) Spinach: senses 4-8 cups (1-2 L) Summer Squash/Zucchini: senses 2-6 cups (500 mL-1.5 L) Frozen Vegetable senses 2-6 cups (500 mL-1.5 L) Shrimp senses 5-10 oz (142-283 g) Manual Steam Cook
--------------------------------------------------------------------------------------------------------------------------------------------------------------------------------------------------------------------------------------------------------------------------------------------------------------------------------------------------	--------------------------------------------------------------------------------------------------------------------------------------------------------------------------------------------------------------------------------------------------------------------------------------------------------------------------

MICROWAVE OVEN CARE

General Cleaning

IMPORTANT: Before cleaning, make sure all controls are off and the microwave oven is cool. Always follow label instructions on cleaning products.

Soap, water and a soft cloth or sponge are suggested unless otherwise noted.

GREASE FILTERS

Do not use ammonia or corrosive cleaning agents such as lye-based oven cleaners.

- Hot water and mild detergent:

Soak filters, then scrub and swish to remove embedded dirt and grease. Rinse well and shake to dry.

- Dishwasher:

Wash separately, not with dirty dishes, because food can be trapped in the filters.

NOTE: Some discoloration of the filters may occur after cleaning them in the dishwasher. This is normal, and will not affect the performance of the grease filters.

MICROWAVE OVEN CAVITY AND DOOR

The gray finish inside the microwave oven cavity is a durable, nonstick coating that makes soils easier to remove.

To avoid damage to the microwave oven cavity, do not use metal or sharp utensils or scrapers, soap-filled scouring pads, abrasive cleaners, steel-wool pads, gritty washcloths or some recycled paper towels. If damage occurs, special touch-up paint may be applied. Call **1-800-4-MY-HOME**® to order. See “Replacement Parts” section for part number.

The inside of the door should be cleaned after every use in order to avoid accumulation of “baked-on” food.

The area where the microwave oven door and frame touch when closed should be kept clean.

Average soil

- Mild, nonabrasive soaps and detergents:

Rinse with clean water and dry with soft, lint-free cloth.

Heavy soil

- Mild, nonabrasive soaps and detergents:

Heat 1 cup (250 mL) of water for 2 to 5 minutes in microwave oven. Steam will soften soil. Rinse with clean water and dry with soft, lint-free cloth.

Odors

- Lemon juice or vinegar:

Heat 1 cup (250 mL) of water with 1 tbs (15 mL) of either lemon juice or vinegar for 2 to 5 minutes in microwave oven.

Microwave Inlet Cover

To avoid arcing and damage to the microwave oven, the microwave inlet cover (see “Parts and Features”) should be kept clean.

- Wipe with wet cloth.

CONTROL PANEL/INTERACTIVE TOUCH DISPLAY

Activate the Control Lock to avoid touch screen activation during cleaning. See “Control Lock” section.

To avoid damage to the control panel/touch display, do not use abrasive cleaners, steel-wool pads or gritty washcloths.

Use gentle pressure when wiping the touch screen.

- Glass cleaner and soft cloth:

Apply glass cleaner to soft cloth, not directly on panel.

- Mild soap, water and soft washcloth

MICROWAVE OVEN DOOR AND EXTERIOR

The area where the microwave oven door and frame touch when closed should be kept clean.

- Mild, nonabrasive soaps and detergents:

Rinse with clean water and dry with soft, lint-free cloth.

- Glass cleaner and paper towels or nonabrasive plastic scrubbing pad:

Apply glass cleaner to towel, not directly to surface.

Stainless Steel (on some models)

To avoid damage to the microwave oven door and exterior, do not use soap-filled scouring pads, abrasive cleaners, steel-wool pads, gritty washcloths or some paper towels. Rub in direction of grain.

- Stainless Steel Cleaner and Polish (not included):

Call **1-800-4-MY-HOME**® to order. See “Replacement Parts” section for part number.

- Liquid detergent or all-purpose cleaner:

Rinse with clean water and dry with soft, lint-free cloth.

- Vinegar for hard water spots

STEAMER VESSEL

- Soft brush, if necessary, to clean holes in steamer insert.

- Dishwasher

Stubborn Stains

To remove stains such as tomato sauce, use a nonabrasive cleanser, a no-scratch pad, or a solution of dishwasher detergent and water (1/4 cup [60 mL] detergent to 1 cup [250 mL] warm water).

TURNTABLE

Replace turntable immediately after cleaning. Do not operate the microwave oven without the turntable in place.

- Mild cleanser and scouring pad

- Dishwasher

BROWNING PAN

To avoid damage to the browning pan, do not use abrasive cleansers or scrubbers.

- Mild cleanser, water and washcloth
- Dishwasher

CONVECTION and GRILL RACKS

Dishwasher cleaning is not recommended. To avoid damage to the convection and grill racks, do not use abrasive cleansers or scrubbers.

- Mild soap, water and washcloth

Replacing Filters

The grease filters should be removed and cleaned at least once a month. The charcoal filters cannot be washed and should be replaced every 6 to 12 months. Do not operate the microwave oven without the filters in place. To order any of the parts, call **1-800-4-MY-HOME**®. See "Replacement Parts" section for part numbers. See "General Cleaning" for cleaning instructions.

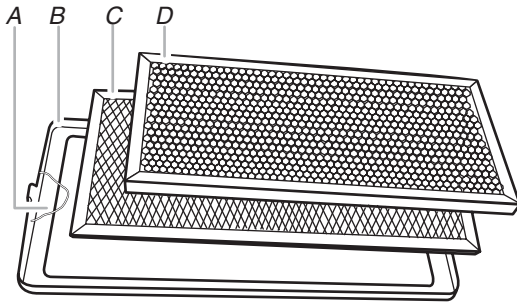

A. Retaining spring
B. Filter frame
C. Grease filter
D. Charcoal filter

To Remove/Replace:

1. Squeeze the small tab on the outer edge of the filter frame inward, and pull down until the frame and filters drop out.

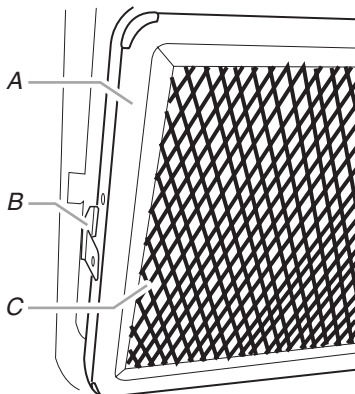

A. Filter frame
B. Small tab
C. Grease filter

2. Replace the filters by inserting the wide tab of the filter frame into the inner portion of the filter housing, then swinging the outside of the frame up until it fits into place.

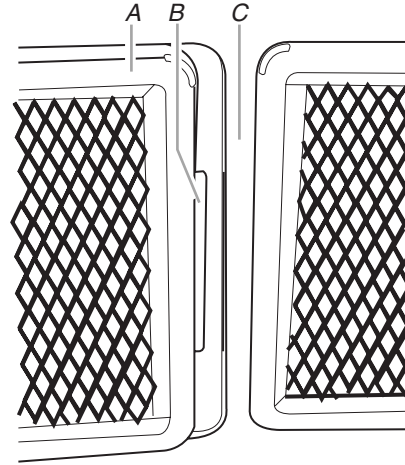

A. Filter frame
B. Wide tab
C. Microwave oven bottom

Replacing Cooktop Light

The cooktop light consists of two 10W low-voltage halogen capsule bulbs. To order any of the parts, call **1-800-4-MY-HOME**®. See "Replacement Parts" section for part numbers.

You will need a TORX® T10 screwdriver to remove the bulb cover mounting screw.

To Replace:

1. Unplug microwave oven or disconnect power.
2. Remove bulb cover mounting screw, and gently open cover.

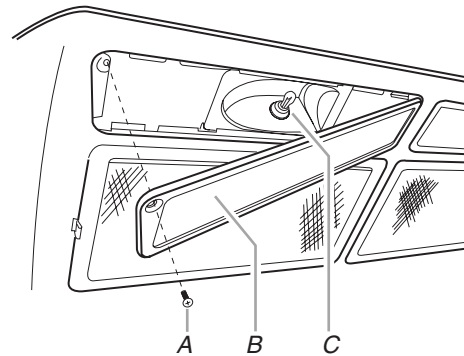

A. Mounting screw
B. Bulb cover lens
C. Halogen bulb

3. Remove the burned-out bulb.
4. Replace bulb, using a tissue or wearing clean cotton gloves to handle the bulb. Do not touch bulb with bare fingers.
5. Close bulb cover and replace mounting screw.
6. Plug in microwave oven or reconnect power.

Replacing Microwave Oven Light

The microwave oven light is a 10W low-voltage halogen capsule bulb. It will automatically come on when the door is opened and when the microwave oven is operating. To order any of the parts, call **1-800-4-MY-HOME®**. See "Replacement Parts" section for part numbers.

You will need a TORX®† T10 screwdriver to remove the bulb cover.

To Replace:

1. Unplug microwave oven or disconnect power.
2. Gently pull vent screen rings and lift the screen off the exhaust vent at the top of the microwave oven.
If using recirculating exhaust venting, skip Step 3.

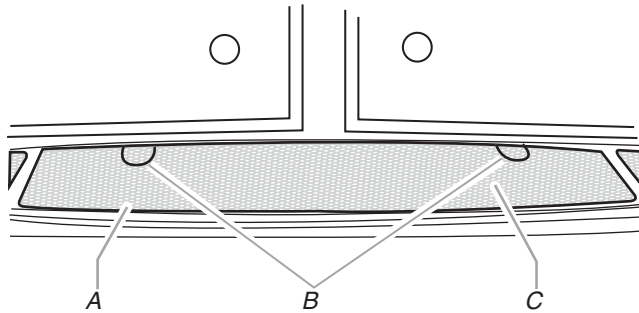

A. Vent screen
B. Rings
C. Bulb cover (under screen)

3. For wall or roof venting, remove the vent deflector by removing the mounting screws (1 from each end), and lifting out the vent deflector.

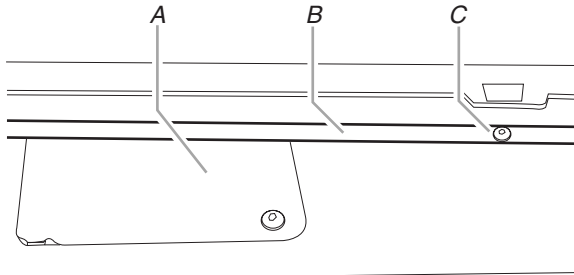

A. Bulb cover
B. Vent deflector
C. Vent deflector mounting screws (2)

4. Remove the bulb cover mounting screw, then lift cover.

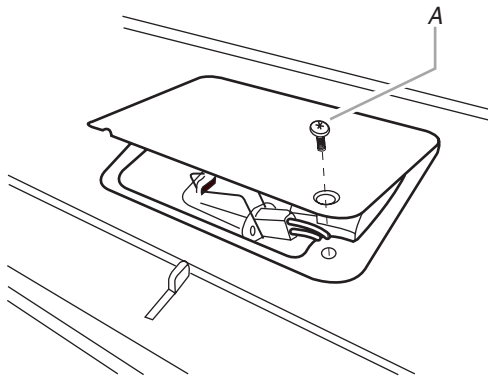

A. Bulb cover mounting screw

5. Remove the burned-out bulb by squeezing the wire clip together, pulling to the right and lifting.

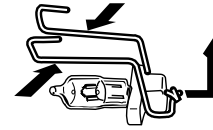

6. Replace bulb, using tissue or wearing clean cotton gloves to handle bulb. Do not touch bulb with bare fingers.
7. Close bulb cover, and fasten with screw.
If using recirculating exhaust venting, skip Step 8.
8. For wall or roof venting, replace the vent deflector removed in Step 3.
9. Replace vent screen.
10. Plug in microwave oven or reconnect power.

Replacement Parts

Replacement parts can be ordered by calling **1-800-4-MY-HOME®**, and referencing these part numbers:

Turntable Part Number 8205992	Browning Pan Part Number 8205996
Turntable Support and Rollers Part Number 8206222	Browning Pan Handle Part Number W10120838
Turntable Hub Part Number 8205994	Grease Filters (2) Part Number W10120839
Grill Rack (tall) Part Number 8206264	Charcoal Filters (2) Part Number W10231551
Convection Rack (short) Part Number 8205995	Cooktop and Microwave Oven Light Part Number 8204670
Steamer Vessel Part Number W10231552	

Cleaning and Maintenance Supplies

Heavy Duty Degreaser Part Number 31552	Stainless Steel Cleaner and Polish Part Number 31462
All-Purpose Appliance Cleaner Part Number 31682	Cavity Touch Up Paint Part Number 8204955

TROUBLESHOOTING

Try the solutions suggested here first in order to avoid the cost of an unnecessary service call.

Nothing will operate

- **Has a household fuse blown, or has a circuit breaker tripped?**
Replace the fuse or reset the circuit breaker. If the problem continues, call an electrician.
- **Is the microwave oven wired properly?**
See Installation Instructions provided with your microwave oven.

Microwave oven will not operate

- **Is the magnetron working properly?**
Try to heat 1 cup (250 mL) of cold water for 2 minutes at 100% cooking power. If water does not heat, try the steps below. If microwave oven still does not operate, contact a Sears trained specialist. See back cover.
- **Is the door completely closed?**
Firmly close door.
- **Is a packaging spacer (on some models) attached to the inside of the door?**
Remove packaging spacer, then firmly close door.
- **Is the electronic microwave oven control set correctly?**
See "Microwave Oven Control" section.
- **Is the Control Lock set?**
See "Control Lock" section.
- **Is the Learning Mode activated?**
See "Learning Mode" section.
- **Does the display show a message about opening the door?**
The door has been closed for an extended period of time (about 5 minutes) after adding food and before starting the microwave oven. Open and close the door, then start the cycle.

Microwave oven door looks wavy

- This is normal and will not affect performance.

Turntable will not operate

- **Has tape been removed from turntable hub?**
Remove tape. See "Turntable" section.
- **Is the turntable properly in place?**
Make sure turntable is correct side up and is sitting securely on the turntable support.
- **Is the turntable support operating properly?**
Remove turntable. Remove and clean turntable support and rollers. Replace turntable support. Replace turntable. Place 1 cup (250 mL) of water on turntable, then restart microwave oven. If it still is not working, contact a Sears trained specialist. See back cover. Do not operate the microwave oven without turntable and turntable support working properly.

Turntable alternates rotation directions

- This is normal and depends on motor rotation at the beginning of the cycle.

Display shows time countdown, but is not operating

- **Is the Timer in use?**
See "Timer" section.
- **Is the Learning Mode in use?**
See "Learning Mode" section.

Steam is coming from the vent screen

- Some steam is normal.

Fan running after cooking is finished

- This is normal for convection and grill use. The fan may run for up to 10 minutes after the cycle ends to cool the microwave oven.

Fan running slower than usual

- **Has the microwave oven been stored in a cold area?**
The fan will run slower until the microwave oven warms up to normal room temperature.

Fan running during cooktop usage

- This is normal. The microwave oven's cooling fan, which is separate from the vent fan, automatically comes on during microwave oven operation to cool the microwave oven. Both the vent fan and the cooling fan may also automatically come on and cycle on and off to cool the microwave oven's controls while the cooktop below is being used.

Cooking times seem too long

- **Is the cooking power set properly?**
See "Microwave Cooking Power" section.
- **Are large amounts of food being heated?**
Larger amounts of food need longer cooking times.
- **Is the incoming voltage less than specified in "Microwave Hood Combination Safety?"**
Have a qualified electrician check the electrical system in the home.

Odor coming from microwave oven during convection cooking

- This is normal for the first few convection cycles. The odor will dissipate with repeated use.

Quartz bulb does not appear to be on

- This is not unusual. See "Grill Element" section.
- **Is the element still working properly?**
To check proper operation of elements, place 2 slices of bread on the tall grill rack, place the rack on the turntable and close the door. Program the microwave oven using Manual Grill – without microwaves – for 4 minutes (see "Manual Method Cooking" section). The bread should toast dark brown. If the bread does not toast, contact a Sears trained specialist. See back cover.

Radio, TV or cordless phone interference

- **Is the radio or TV receiver near the microwave oven?**
Move the receiver away from the microwave oven, or adjust the radio or TV antenna.
- **Are the microwave oven door and sealing surfaces clean?**
Make sure these areas are clean.
- **Is the cordless phone frequency 2.4 GHz?**
Some 2.4 GHz-based cordless phones and home wireless networks may experience static or noise while the microwave oven is on. Use a corded phone or a different frequency cordless phone, or avoid using these items during microwave oven operation.

Get it fixed, at your home or ours!

Your Home

For expert troubleshooting and home solutions advice:

manage my home

www.managemyhome.com

For repair – **in your home** – of **all** major brand appliances, lawn and garden equipment, or heating and cooling systems, **no matter who made it, no matter who sold it!**

For the replacement parts, accessories and owner's manuals that you need to do-it-yourself.

For Sears professional installation of home appliances and items like garage door openers and water heaters.

1-800-4-MY-HOME® (1-800-469-4663)

Call anytime, day or night (U.S.A. and Canada)

www.sears.com www.sears.ca

Our Home

For repair of carry-in items like vacuums, lawn equipment, and electronics, call anytime for the location of your nearest

Sears Parts & Repair Service Center

1-800-488-1222 (U.S.A.) **1-800-469-4663** (Canada)

www.sears.com www.sears.ca

To purchase a protection agreement on a product serviced by Sears:

1-800-827-6655 (U.S.A.) **1-800-361-6665** (Canada)

Para pedir servicio de reparación a domicilio, y para ordenar piezas:

1-888-SU-HOGAR®

(1-888-784-6427)

Au Canada pour service en français:

1-800-LE-FOYER^{MC}

(1-800-533-6937)

www.sears.ca

Sears