

Installation Instructions

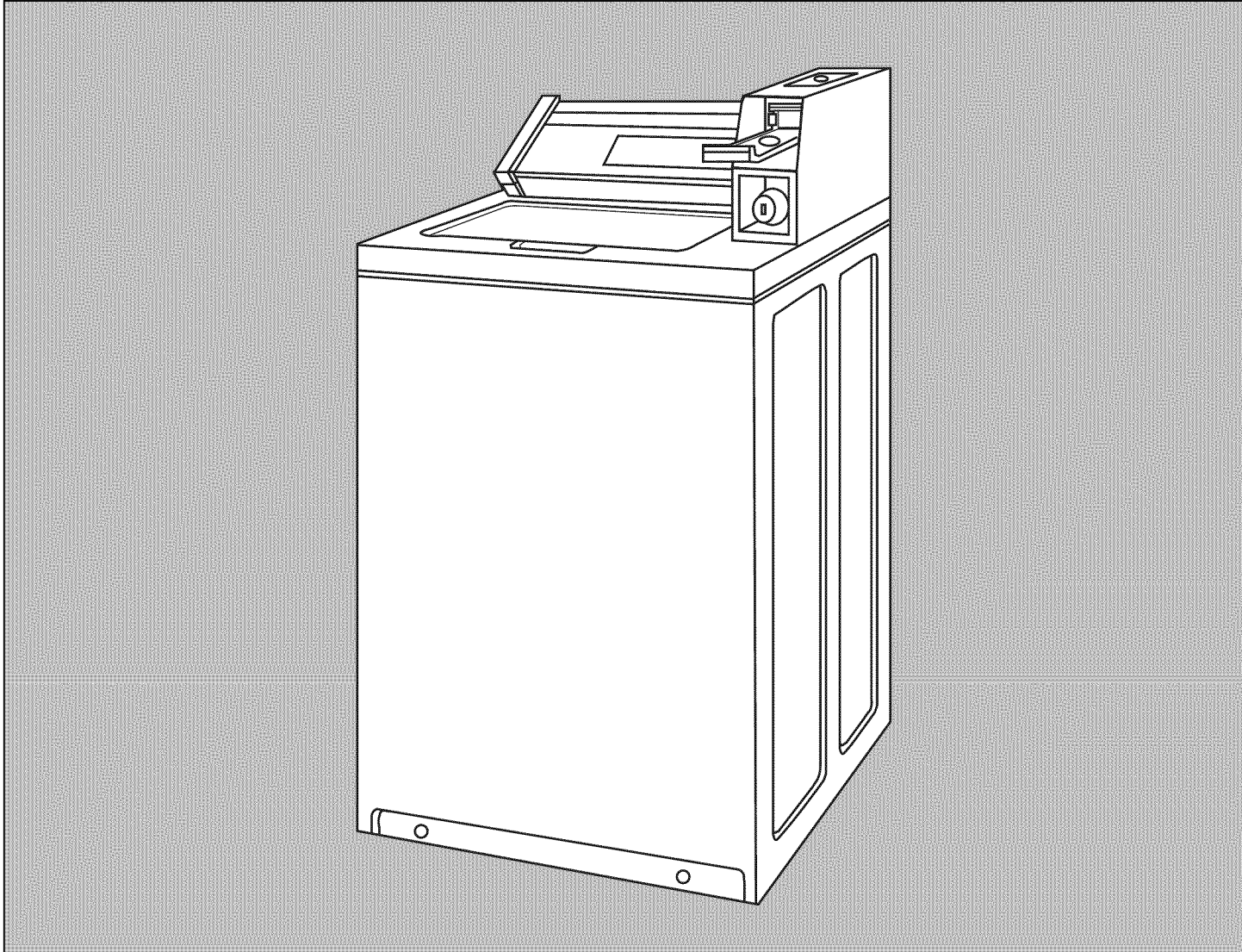

Part No. 3360618

IMPORTANT: Read and save these instructions

IMPORTANT:

Installer: Leave Installation Instructions with the owner.

Owner: Keep Installation Instructions for future reference.

Save Installation Instructions for local electrical inspector's use.

COMMERCIAL ELECTRONIC WASHER

120-volt, 60-Hz Models



www.whirlpool.com

Before you start...

Your safety and the safety of others is very important.

We have provided many important safety messages in this manual and on your appliance. Always read and obey all safety messages.



This is the safety alert symbol. This symbol alerts you to hazards that can kill or hurt you and others. All safety messages will be preceded by the safety alert symbol and the word "DANGER" or "WARNING". These words mean:

⚠ DANGER

You **will** be killed or seriously injured if you don't follow instructions.

⚠ WARNING

You **can** be killed or seriously injured if you don't follow instructions.

All safety messages will identify the hazard, tell you how to reduce the chance of injury, and tell you what can happen if the instructions are not followed.

Do Not store or operate washer below 32°F (some water may remain in washer).

See Use & Care Guide for "Winterizing" information.

Check location where washer will be installed. Proper installation is your responsibility. Make sure you have everything necessary for correct installation.

Single washer installations require 12 inch minimum risers to provide an air cushion and prevent noise and damage to valves.

Grounded electrical outlet is required. See Electrical requirements.

Hot and cold water faucets must be within 4 feet of the back of the washer and provide water pressure 10-100 PSI. A pressure reduction valve should be used in the supply line where inlet pressure entering the building exceeds 100 PSI to prevent damage to the washer mixing valve.

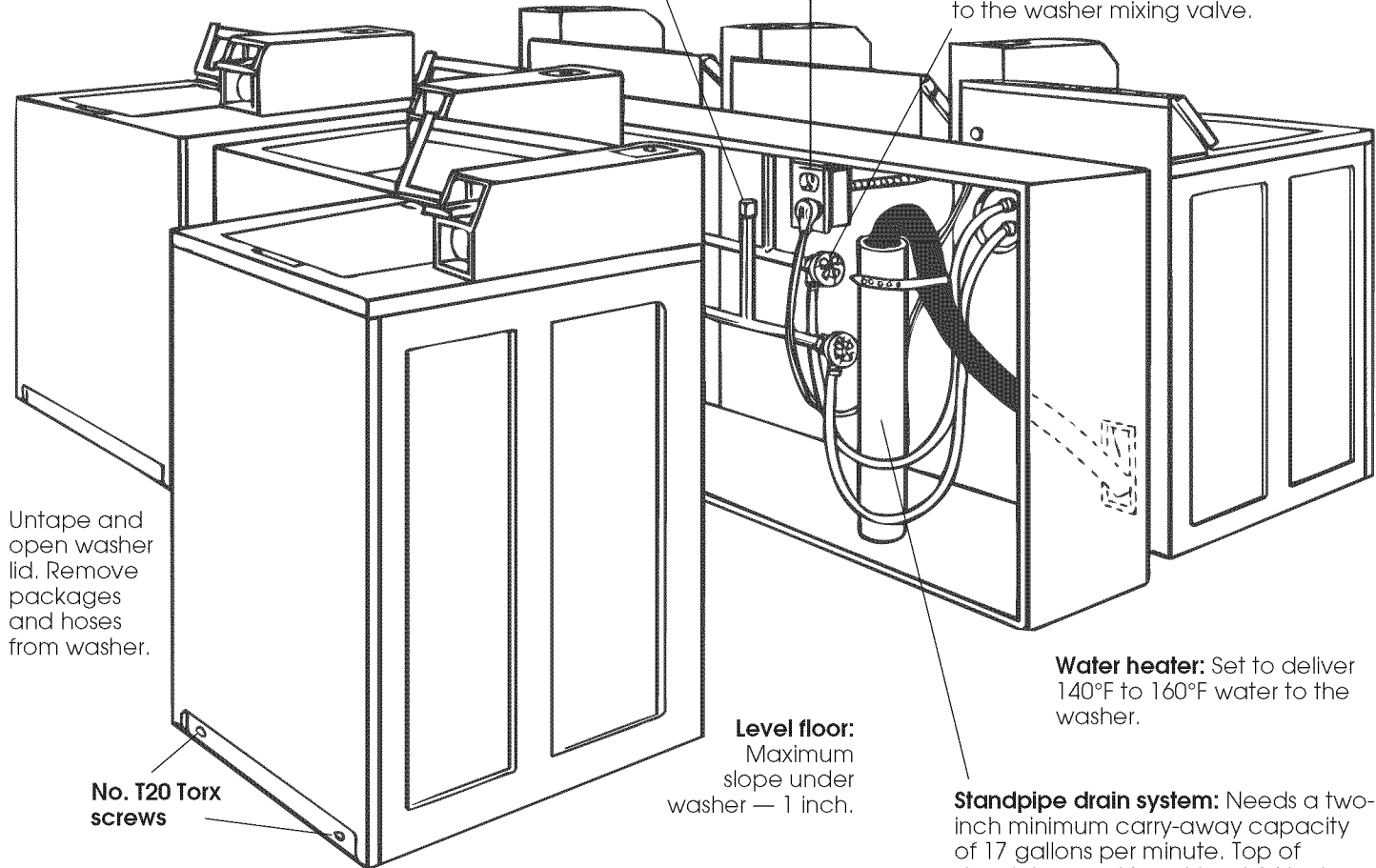

Untape and open washer lid. Remove packages and hoses from washer.

No. T20 Torx screws

Level floor:
Maximum slope under washer — 1 inch.

Water heater: Set to deliver 140°F to 160°F water to the washer.

Standpipe drain system: Needs a two-inch minimum carry-away capacity of 17 gallons per minute. Top of standpipe must be at least 34 inches high and no higher than 72 inches from bottom of washer.

On coin-operated washers, front access to the pump area is available by removing the two, No. T20 Torx screws and then removing the front panel. Non-coin-operated washers do not have a removable front panel. The cabinet and top assembly must be removed by removing clips under console on the non-coin-operated washer.

Non-coin-operated washers are equipped with a console, push to start timer, selector switches and indicator lights (not pictured).

A floor drain should be provided under the bulkhead. Prefabricated bulkheads with electrical outlets, water supply lines and drain facilities should be used only where local codes permit.

Support: Floor must be sturdy enough to support loaded washer weight of 315 pounds.

Important: Observe all governing codes and ordinances.

Tools needed for installation:

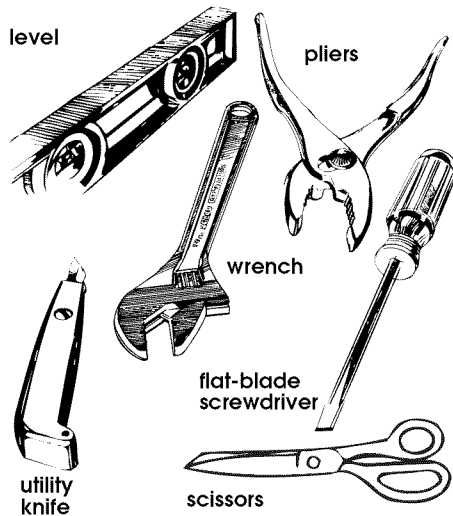

Parts supplied for installation:

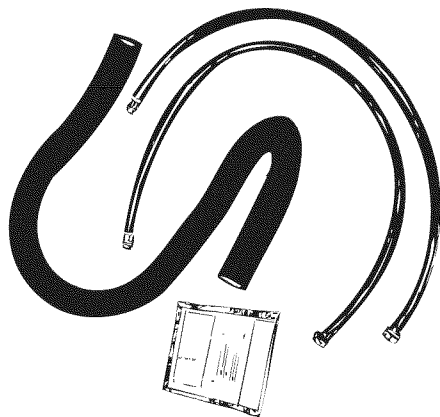

Remove parts from packages. Check that all parts were included.

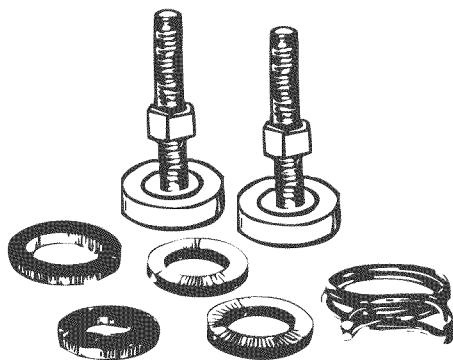

- 1 hose clamp
- 2 inlet hoses
- 4 flat water hose washers
- 2 front-leveling legs with nuts
- 1 drain hose

Electrical requirements

⚠ WARNING

Electrical Shock Hazard

Plug into a grounded 3-prong outlet.
Do not remove ground prong.
Do not use an adapter.
Do not use an extension cord.
Failure to follow these instructions can result in death, fire, or electrical shock.

If codes permit and a separate ground wire is used, it is recommended that a qualified electrician determine that the ground path is adequate.

Do Not ground to a gas pipe.

Check with a qualified electrician if you are not sure the washer is properly grounded.

Do Not have a fuse in the neutral or ground circuit.

A 120-volt, 60-Hz, AC-only, 15- or 20-ampere fused electrical supply is required. (Time-delay fuse or circuit breaker is recommended.) It is recommended that a separate circuit serving only this appliance be provided.

Recommended ground method

For your personal safety, this appliance must be grounded. This appliance is equipped with a power supply cord having 3-prong ground plug. To minimize possible shock hazard, the cord must be plugged into a mating 3-prong ground-type outlet, grounded in accordance with local codes and ordinances. See Figure 1. If a mating outlet is not available, it is the personal responsibility and obligation of the customer to have a properly grounded 3-prong outlet installed by a qualified electrician.

WARNING – Improper connection of the equipment-grounding conductor can result in a risk of electric shock. Check with a qualified electrician or serviceman if you are in doubt as to whether the appliance is properly grounded. Do not modify the plug provided with the appliance – if it will not fit the outlet, have a proper outlet installed by a qualified electrician.

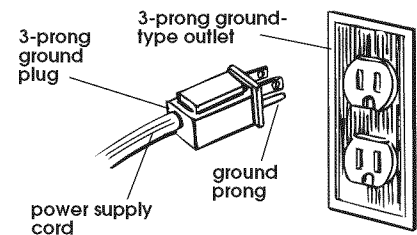

Figure 1

Now start...
With washer in laundry area.

⚠ WARNING

Excessive Weight Hazard

Use two or more people to move and install washer.
Failure to do so can result in back or other injury.

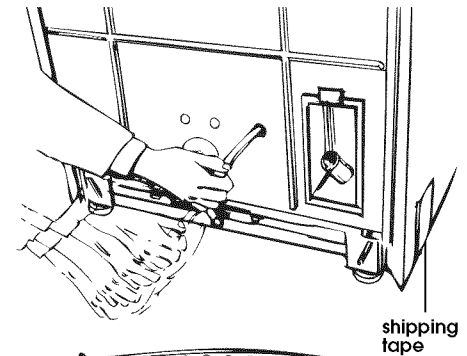

Pull the strap completely out of the washer.

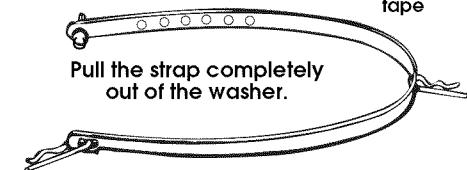

- 1.** Remove tape that covers shipping strap. Pull to completely remove the shipping strap with 2 cotterpins from the inside of the washer.

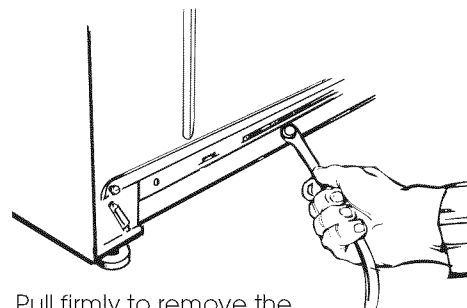

Pull firmly to remove the end of shipping strap from the back of the washer. The shipping strap plug must be completely removed from the washer for the self-leveling legs to be released.

Save the shipping strap for use in Step 6.

Use new hoses and washers that came with your Whirlpool washer.

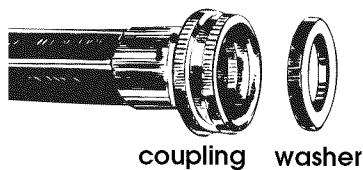

coupling washer

2. Insert a flatwasher into **each** end of the inlet hoses. Check that washers are firmly seated in couplings.

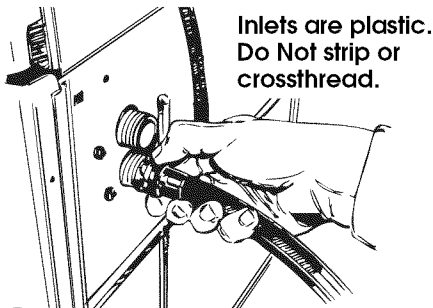

Inlets are plastic. Do Not strip or crossthread.

3. Attach hose to bottom inlet valve opening first. Then second hose to top inlet. Tighten couplings by hand; then use pliers to make an additional two-thirds turn.

Slide washer onto cardboard or hardboard before moving across floor.

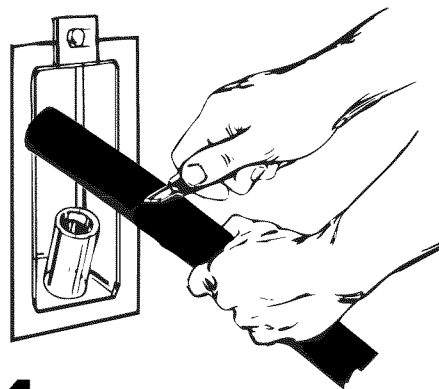

4. Move washer close to final position. Put "hook" end of drain hose into standpipe. Estimate length of drain hose needed when washer is in final position. Hose must be cut exactly to length so "hook" end is held tightly over edge of standpipe. If drain hose is too long, cut straight end of hose. **(Do Not cut "hook" shaped end of drain hose.)**

DO NOT FORCE EXCESS LENGTH OF DRAIN HOSE DOWN THE STANDPIPE. THIS COULD CAUSE SIPHONING. See Step 6.

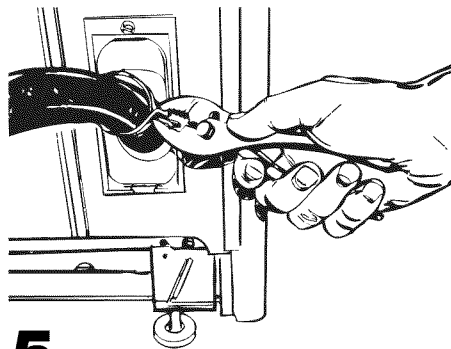

5. Place hose clamp over washer drain connector. Push drain hose onto washer connector. Use pliers to open clamp and slide clamp over drain hose. Check for good fit.

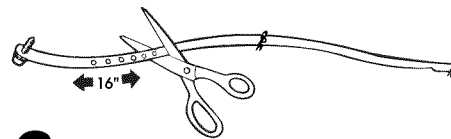

6. Measure and mark a point approximately 16 inches from the plug end of the shipping strap. Cut this shipping strap at this point.

Check that hose is not twisted or kinked and is securely in place.

Put "hook" end of drain hose into standpipe. Tightly wrap the shipping strap around the standpipe. Push plug into the nearest hole in the shipping strap.

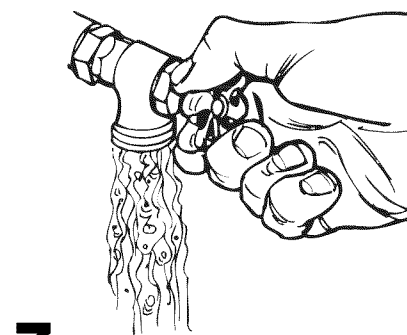
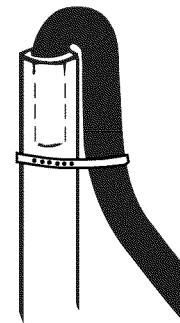

7. **Before** attaching water inlet hoses, run water through both faucets into a bucket. This will get rid of particles in water lines that might clog hoses. Mark which is the hot water faucet.

8. Attach bottom hose (inlet marked "H") to hot water faucet. Attach top hose (inlet marked "C") to cold water faucet. Tighten coupling to faucet by hand; then use pliers to make final two-thirds turn.

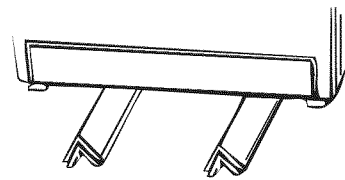

9. Stack two corner posts on top of each other. Tilt washer backwards and insert corner posts 3 inches in from one side of washer as shown. Repeat with other corner posts on other side of washer.

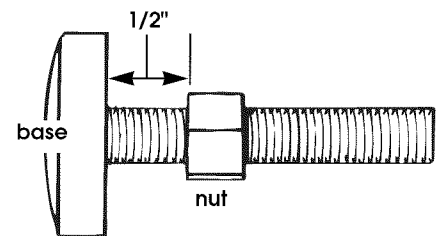

10. Use legs and nuts from parts package. Screw nut down to within 1/2 inch of base.

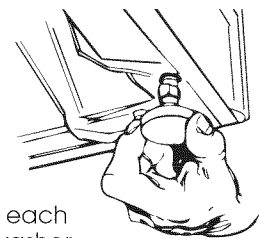

11. Insert legs into correct holes at each front corner of washer until nuts touch washer. **Do Not** tighten nuts until Step 14.

12. Tilt washer backward and remove corner posts. Gently lower washer to floor.

Move washer to its permanent location. Remove cardboard or hardboard from under washer.

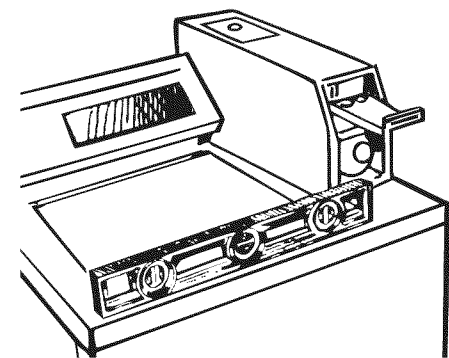

13. Tilt washer forward raising back legs 1 inch off of floor. To adjust rear self-leveling legs, gently lower washer to floor. Check levelness of the washer by placing a carpenter's level on top of the washer, first side to side; then front to back.

Owner options (coin-operated models)

CAUTION: Disconnect power cord.

- For **WARM RINSE** and **WATER SAVER**:
 - Remove screws from each end of the console bottom.
 - Pull the console bottom forward; lift and tilt it back.
 - WARM RINSE**
 - Connect J1 to J2
 - SAVE WATER**
 - Pull out tab on water-level switch.
- If use of a larger coin vault, lock and key is desired, conversion bar in lower portion of coin vault area can be removed.
- If additional security is needed, top and cabinet can be locked to washer back panel by using a "screw type" lock and key in space provided in top panel under console. The "screw type" lock and key are available from usual industry sources.

Typical full load sizes.

Load Type	Loading Suggestion	Load Type	Loading Suggestion
Mixed Load	3 double sheets 4 pillowcases 6 pair shorts 8 T-shirts 2 shirts 2 blouses 8 handkerchiefs	Heavy work clothes	3 pair pants 3 shirts 1 coverall 4 pair jeans 1 overall
Permanent Press	2 double or 1 king size sheet 1 tablecloth 1 dress 1 blouse 2 slacks 3 shirts 2 pillowcases	Knits	3 blouses 4 slacks 6 shirts 4 tops 4 dresses

Check list for washer operation

Check the following if the washer is not operating properly:

- Power supply cord is plugged in.
- Circuit breaker is not tripped or fuse blown.
- Timer has been advanced to start of a cycle.
- Water faucets are turned on.
- Inlet and drain hoses are not kinked.
- Washer lid is closed.
- Inlet valve is frozen if not protected from the weather.
- Suds level. Excess suds will slow the spin and cause poor rinsing. Operate the washer through a complete cycle with no detergent. Use less detergent or a controlled suds type detergent in future loads.

Operating Tips

⚠ WARNING



Fire Hazard

Never place items in the washer that are dampened with gasoline or other flammable fluids.

No washer can completely remove oil.

Do not dry anything that has ever had any type of oil on it (including cooking oils).

Doing so can result in death, explosion, or fire.

It is recommended that fiberglass items not be washed in coin-operated washers. If these items are washed in the washer, run the washer through a complete cycle to rinse any residue away that might be left in the washer.

Moving the washer to a new location...

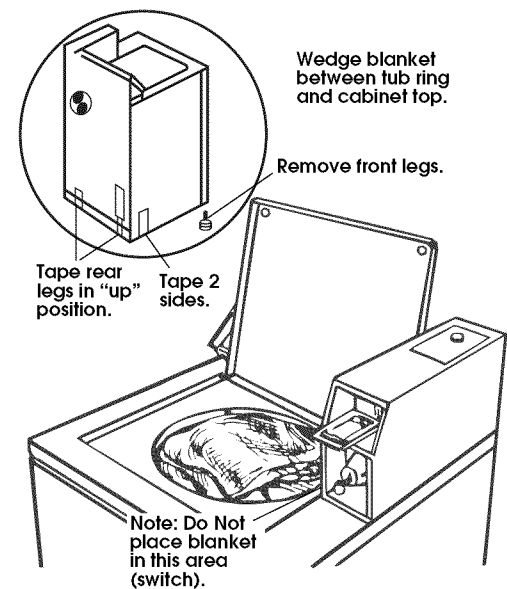

- Remove the front legs from the base of the washer.
- Place both rear leveling legs in the upper position and tape securely.
- Apply tape to the side and bottom of the cabinet near the rear.
- Open washer lid, wedge a blanket between the tub ring and the cabinet top restricting the tub movement.
- Handle washer carefully. **Do Not drop washer while using hand truck.**

