



High-Efficiency Top-Loading Washer Use and Care Guide

Laveuse à chargement par le dessus À haute efficacité Guide d'utilisation et d'entretien

Para una versión de estas instrucciones en español, visite www.whirlpool.com

Table of Contents

WASHER SAFETY	2
CONTROL PANEL AND FEATURES	4
CYCLE GUIDE	5
USING YOUR WASHER	6
WASHER MAINTENANCE	9
TROUBLESHOOTING	10
WARRANTY	14
ASSISTANCE OR SERVICE	Back Cover

Table des matières

SÉCURITÉ DE LA LAVEUSE	15
TABLEAU DE COMMANDE ET CARACTÉRISTIQUES	17
GUIDE DE PROGRAMMES	18
UTILISATION DE LA LAVEUSE	19
ENTRETIEN DE LA LAVEUSE	22
DÉPANNAGE	24
GARANTIE	29
ASSISTANCE OU SERVICE	Couverture arrière

Washer Safety

Your safety and the safety of others are very important.

We have provided many important safety messages in this manual and on your appliance. Always read and obey all safety messages.



This is the safety alert symbol.

This symbol alerts you to potential hazards that can kill or hurt you and others.

All safety messages will follow the safety alert symbol and either the word "DANGER" or "WARNING." These words mean:

! DANGER

You can be killed or seriously injured if you don't immediately follow instructions.

! WARNING

You can be killed or seriously injured if you don't follow instructions.

All safety messages will tell you what the potential hazard is, tell you how to reduce the chance of injury, and tell you what can happen if the instructions are not followed.

IMPORTANT SAFETY INSTRUCTIONS

WARNING: To reduce the risk of fire, electric shock, or injury to persons when using the washer, follow basic precautions, including the following:

- Read all instructions before using the washer.
- Do not wash articles that have been previously cleaned in, washed in, soaked in, or spotted with gasoline, dry-cleaning solvents, other flammable, or explosive substances as they give off vapors that could ignite or explode.
- Do not add gasoline, dry-cleaning solvents, or other flammable, or explosive substances to the wash water. These substances give off vapors that could ignite or explode.
- Under certain conditions, hydrogen gas may be produced in a hot water system that has not been used for 2 weeks or more. **HYDROGEN GAS IS EXPLOSIVE.** If the hot water system has not been used for such a period, before using the washing machine, turn on all hot water faucets and let the water flow from each for several minutes. This will release any accumulated hydrogen gas. As the gas is flammable, do not smoke or use an open flame during this time.
- Do not allow children to play on or in the washer. Close supervision of children is necessary when the washer is used near children.
- Before the washer is removed from service or discarded, remove the door or lid.
- Do not reach into the washer if the drum, tub or agitator is moving.
- Do not install or store the washer where it will be exposed to the weather.
- Do not tamper with controls.
- Do not repair or replace any part of the washer or attempt any servicing unless specifically recommended in this manual or in published user-repair instructions that you understand and have the skills to carry out.
- See "Electrical Requirements" located in the installation instructions for grounding instructions.

SAVE THESE INSTRUCTIONS

State of California Proposition 65 Warnings:

WARNING: This product contains one or more chemicals known to the State of California to cause cancer.

WARNING: This product contains one or more chemicals known to the State of California to cause birth defects or other reproductive harm.

Model and Serial Number Location

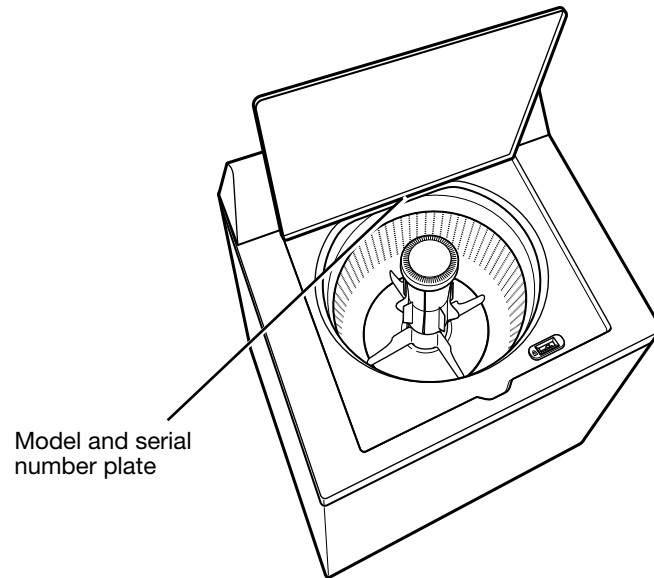

For future reference, please record the numbers below:

Model Number _____

Serial Number _____

Key Code Number _____

Control Panel and Features

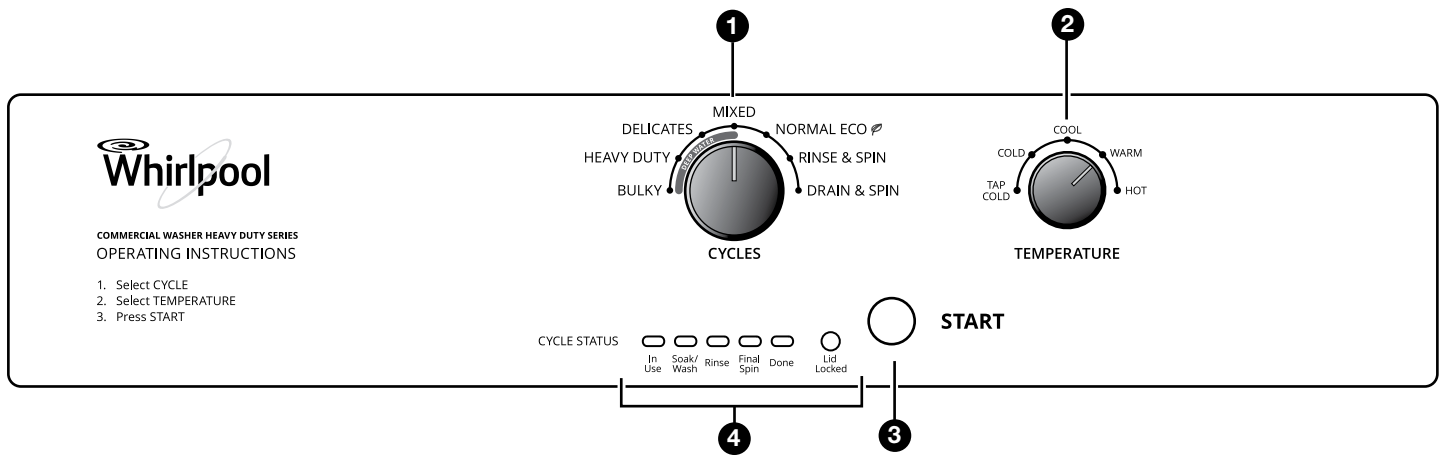

Not all features and options are available on all models.
Appearance may vary.

1 WASH CYCLE KNOB

Use the Wash Cycle knob to select cycles on your washer. Knob does not advance during the progress of the cycle – see cycle status lights for each stage of the process. See “Cycle Guide” for detailed descriptions of cycles.

Select the cycle most suitable for your load. Items need to move freely. Tightly packing can lead to poor cleaning performance and may increase wrinkling and tangling.

2 TEMPERATURE

Temperature senses and maintains uniform water temperatures by regulating incoming hot and cold water.

Select a wash temperature based on the type of fabric and soils being washed. For best results, and following the garment label instructions, use the warmest wash water safe for your fabric.

- Normal Eco, Warm, and Hot water may be cooler than your previous washer. Deep Water cycles will provide higher temperatures for the wash cycle.
- Even in a cold and cool water wash, some warm water may be added to the washer to maintain a minimum temperature.

3 START BUTTON

Press to start the selected cycle. To unlock the lid during Final Spin, press and hold for 3 seconds to pause the cycle. Press and hold for 10 seconds to cancel a cycle.

NOTE: The lid will unlock once the basket stops spinning.

4 CYCLE STATUS LIGHTS INDICATOR



The Cycle Status lights show the progress of a cycle. At each stage of the process, you may notice sounds or pauses that are different from traditional washers.

IN USE

This LED illuminates after the cycle starts and remains illuminated until the cycle is complete.

SOAK/WASH

This LED remains illuminated during the Wash portion of the cycle.

RINSE

This LED remains illuminated during the Rinse portion of the cycle. Fabric softener can be added at this stage of the cycle.

FINAL SPIN/LID LOCKED

The Final Spin LED and the Lid Locked LED will both remain illuminated during this portion of the cycle. If you need to open the lid prior to cycle completion, press and hold START for 3 seconds.

DONE

This LED illuminates when the cycle is complete and will turn off when the lid is open.

Cycle Guide

For best fabric care, choose the cycle that best fits the load being washed.
Not all cycles and options are available on all models.

Items to wash:	Cycle:	Wash Temperature*:	Spin Speed:	Cycle Details:
Cottons, linens	Normal Eco	Hot Warm Cool Cold Tap Cold	High	Use this cycle for normally soiled cottons.
Mixed-garment loads	Mixed	Hot Warm Cool Cold Tap Cold	High	Use this cycle for a wide variety of mixed-garment loads. This cycle features a deep bath rinse.
Sturdy items and mixed-garment loads	Heavy Duty	Hot Warm Cool Cold Tap Cold	High	Use this cycle for heavily soiled or sturdy items. This cycle features a deep bath rinse.
No-iron fabrics, perm. press, synthetics, machine-wash silks, hand-washed fabrics	Delicates	Hot Warm Cool Cold Tap Cold	Low	Use this cycle to wash lightly soiled loads of no-iron fabrics such as sport shirts, blouses, casual business clothes, permanent press, and blends. Also use to wash lightly soiled garments indicating "Machine Washable Silks" or "Gentle" cycle on the care label. Place small items in mesh garment bags before washing. This cycle features a deep bath rinse.
Large items such as sheets, sleeping bags, small comforters, jackets, small washable rugs	Bulky	Hot Warm Cool Cold Tap Cold	High	Use this cycle to wash large items such as jackets and small comforters. The washer will fill with enough water to wet down the load before the Wash portion of the cycle begins and uses a higher water level than other cycles.
Swimsuits and items requiring rinsing without detergent	Rinse & Spin	Cold	High	Use this cycle to wash swimsuits or items requiring rinsing without detergent. The washer combines a rinse and a high-speed spin for loads requiring an additional rinse cycle or to complete a load after a power interruption. Also, use this cycle for loads that require rinsing only.
Hand-washed items or dripping wet items	Drain & Spin	N/A	High	Use this cycle to drain the washer after cancelling a cycle or completing a cycle after a power interruption. This cycle uses a high-speed spin to reduce drying times for heavy items or hand-washed items.

*All rinses are cold.

Using Your Washer

⚠ WARNING



Fire Hazard

Never place items in the washer that are dampened with gasoline or other flammable fluids.

No washer can completely remove oil.

Do not dry anything that has ever had any type of oil on it (including cooking oils).

Doing so can result in death, explosion, or fire.

⚠ WARNING



Electrical Shock Hazard

Plug into a grounded 3 prong outlet.

Do not remove ground prong.

Do not use an adapter.

Do not use an extension cord.

Failure to follow these instructions can result in death, fire, or electrical shock.

1. Sort and prepare your laundry

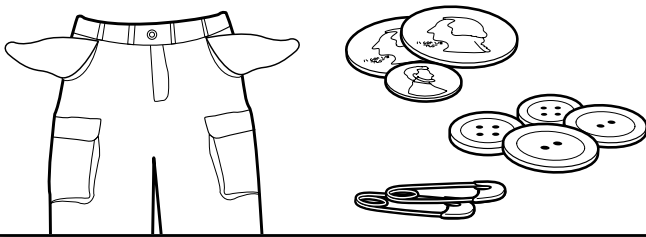

- Empty pockets. Loose change, buttons, or any small object can pass under the agitator and become trapped, causing unexpected sounds.
- Sort items by recommended cycle, water temperature, and colorfastness.
- Separate heavily soiled items from lightly soiled.
- Separate delicate items from sturdy fabrics.
- Do not dry garments if stains remain after washing, because heat can set stains into fabric.
- Treat stains promptly.
- Close zippers, fasten hooks, tie strings and sashes, and remove non-washable trim and ornaments.
- Mend rips and tears to avoid further damage to items during washing.

Helpful Tips:

- When washing waterproof or water-resistant items, load evenly.
- Use mesh garment bags to help avoid tangling when washing delicate or small items.
- Turn knits inside out to avoid pilling. Separate lint-takers from lint-givers. Synthetics, knits, and corduroy fabrics will pick up lint from towels, rugs, and chenille fabrics.
- For best performance, heavier items like jeans, towels, and blankets should be placed in first so they are at the bottom of the mixed load.

NOTE: Always read and follow fabric care label instructions to avoid damage to your garments.

2. Add laundry products

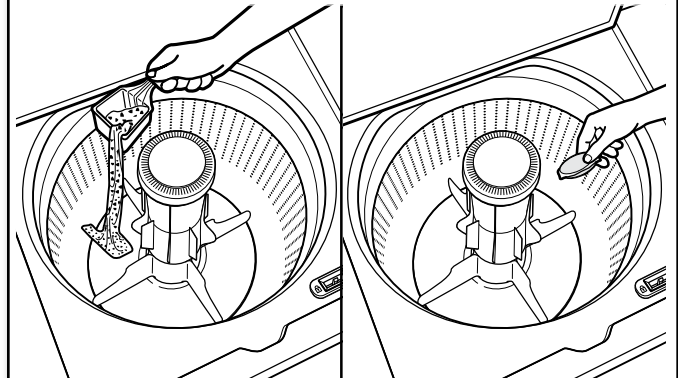

IMPORTANT: Add a measured amount of detergent or single-dose laundry packet into the basket.

If using Oxi-type boosters, color-safe bleach, or fabric softener crystals, add to the bottom of the washer basket before adding clothes.

If using liquid chlorine bleach (optional), manually add product to wash water.

Do not overfill, dilute, or use more than 1 cup (250 mL) of liquid chlorine bleach. Do not use color-safe bleach or Oxi products in the same cycle with liquid chlorine bleach.

NOTE: Follow the manufacturer's instructions to determine the amount of laundry products to use. Manufacturer suggests using HE detergent.

3. Load laundry into washer

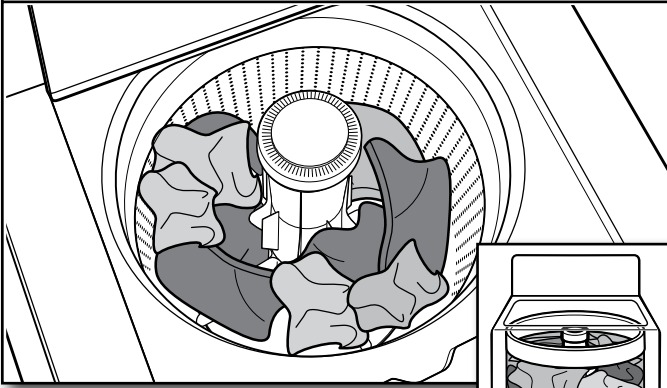

Load garments in loose heaps evenly around basket wall. For best results, do not pack the load tightly. Do not wrap large items such as sheets around the agitator; load them in loose piles around the sides of the basket. Try mixing different sized items to reduce tangling.

IMPORTANT: Do not tightly pack or force items into washer. Items need to move freely for best cleaning and to reduce wrinkling and tangling. Load heavier items in first. Do not load above agitator cap. Do not load clothes above white inner collar.

4. Adding fabric softener to optional dispenser

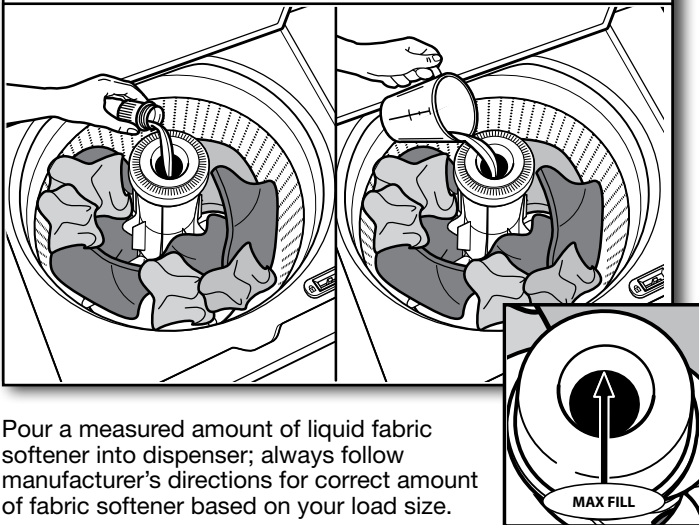

Pour a measured amount of liquid fabric softener into dispenser; always follow manufacturer's directions for correct amount of fabric softener based on your load size.

Dilute liquid fabric softener by filling the dispenser with warm water until liquid reaches the underside of the rim. See max fill line arrows.

Adding Liquid Fabric Softener Manually to Wash Load

During the final rinse, wait until the washer has completed filling. At that time, water valve will shut off and you will not hear any water entering the washer. Lift the lid and add the measured recommended amount of liquid fabric softener. Do not use more than the recommended amount. Close lid.

5. Select cycle

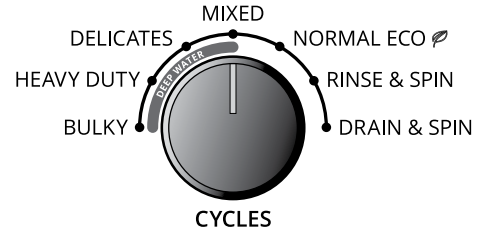

Appearance may vary.

Turn Cycle knob to choose your wash cycle. For more information, see "Cycle Guide."

6. Select TEMPERATURE

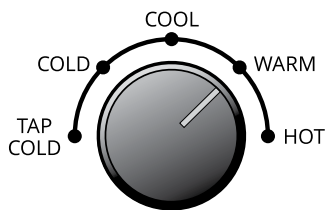

TEMPERATURE

Once you select a cycle, select the desired wash temperature by turning the Temperature knob to the appropriate setting based on your load. All rinses are tap cold.

NOTE: Always read and follow fabric care label instructions to avoid damage to your garments.

Temperature	Suggested Fabrics
Hot Some cold water is added to save energy. This will be cooler than your hot water heater setting.	Whites and pastels Durable garments Heavy soils
Warm Some cold water will be added, so this will be cooler than what your previous washer provided.	Bright colors Moderate to light soils
Cool Warm water may be added to assist in soil removal and to help dissolve detergents.	Colors that bleed or fade Light soils
Cold This is the temperature from your faucet. If your tap cold water is less than 50°F (10°C), warm water may be added to assist in soil removal and help dissolve detergent.	Dark colors that bleed or fade Light soils
Tap Cold This is the temperature from your faucet.	Dark colors that bleed or fade Light soils

7. Press START to begin wash cycle

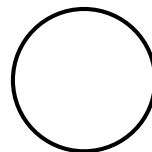

START

Press the Start button to start the wash cycle. When the cycle has finished, the Done indicator will light. Promptly remove garments after cycle has completed to avoid odor, reduce wrinkling, and avoid rusting of metal hooks, zippers, and snaps.

Washer Maintenance

WATER INLET HOSES

Replace inlet hoses after 5 years of use to reduce the risk of hose failure. Periodically inspect and replace inlet hoses if bulges, kinks, cuts, wear, or leaks are found.

When replacing your inlet hoses, mark the date of replacement on the label with a permanent marker.

WASHER CARE

Recommendations to Help Keep Your Washer Clean and Performing at Its Best

1. Always follow the detergent manufacturer's instructions regarding the amount of detergent to use. Never use more than the recommended amount because that may increase the rate at which detergent and soil residue accumulate inside your washer which, in turn, may result in undesirable odor.
2. Use warm and hot wash water settings sometimes (not exclusively cold water washes), because they do a better job of controlling the rate at which soils and detergent accumulate.
3. Always leave the washer lid open between uses to help dry out the washer and prevent the buildup of odor-causing residue.

Cleaning Your Top Loading Washer

Read these instructions completely before beginning the routine cleaning processes recommended below. This Washer Maintenance Procedure should be performed, at a minimum, once per month or every 30 wash cycles, whichever occurs sooner, to control the rate at which soils and detergent may otherwise accumulate in your washer.

Cleaning the Inside of the Washer

To keep your washer odor-free, follow the usage instructions provided above, and use this recommended cleaning procedure:

Recommended Cycle for Cleaning the Washer

For optimal cleaning use chlorine bleach:

- a. Open the washer lid and remove any clothing or items.
- b. Add 1 cup (236 mL) of liquid chlorine bleach to the wash basket.

NOTE: Use of more liquid chlorine bleach than is recommended above could cause washer damage over time.

- c. Close the washer lid.
- d. Do not add any detergent or other chemical to the washer when following this procedure.
- e. Select the Heavy Duty cycle.
- f. Press the Start button to start the cycle.

NOTE: Do not interrupt cycle.

Cleaning the Optional Fabric Softener Dispenser

After a period of using your washer, you may find some residue buildup in the dispenser. To remove residue from the dispenser, wipe with a damp cloth and towel dry. Use an all-purpose surface cleaner, if needed.

Cleaning the Outside of the Washer

Use a soft, damp cloth or sponge to wipe away any spills. Use only mild soaps or cleaners when cleaning external washer surfaces.

IMPORTANT: To avoid damaging the washer's finish, do not use abrasive products.

NOTE: The Clean Washer cycle should be used 1 or 2 times a year. Check the Tech Sheet for access to the Clean Washer cycle in the Diagnostic Test Mode.

NON-USE AND VACATION CARE

If moving, or not using your washer for a period of time, follow these steps:

1. Unplug or disconnect power to washer.
2. Turn off water supply to washer, to avoid flooding due to water pressure surge.

WINTER STORAGE CARE

IMPORTANT: To avoid damage, install and store washer where it will not freeze. Because some water may stay in hoses, freezing can damage washer. If storing or moving during freezing weather, winterize your washer.

To winterize washer:

1. Shut off both water faucets; disconnect and drain water inlet hoses.
2. Put 1 qt. (1 L) of R.V.-type antifreeze in basket and run a wash cycle for about 30 seconds to mix antifreeze and remaining water.
3. Unplug washer or disconnect power.

TRANSPORTING YOUR WASHER

1. Shut off both water faucets. Disconnect and drain water inlet hoses.
2. If washer will be moved during freezing weather, follow "Winter Storage Care" directions before moving.
3. Disconnect drain hose from drain system and drain any remaining water into a pan or bucket. Disconnect drain hose from back of washer.
4. Unplug power cord.
5. Place inlet hoses and drain hose inside washer basket.
6. Drape power cord over edge and into washer basket.
7. Place packing tray from original shipping materials back inside washer. If you do not have packing tray, place heavy blankets or towels into basket opening. Close lid and place tape over lid and down front of washer. Keep lid taped until washer is placed in new location.
8. Reinstall bottom shipping cone if available.

⚠ WARNING



Electrical Shock Hazard

Plug into a grounded 3 prong outlet.

Do not remove ground prong.

Do not use an adapter.

Do not use an extension cord.

Failure to follow these instructions can result in death, fire, or electrical shock.

REINSTALLING/USING WASHER AGAIN

To reinstall washer after non-use, vacation, winter storage, or moving:

1. Refer to Installation Instructions to locate, level, and connect washer.
2. Before using again, run washer through the following recommended procedure:

To use washer again:

1. Flush water pipes and hoses. Reconnect water inlet hoses. Turn on both water faucets.
2. Plug in washer or reconnect power.
3. Run washer through Normal cycle to clean washer and remove antifreeze, if used. Use half the manufacturer's recommended amount of detergent for a medium-size load.

Troubleshooting

Before calling for service on your washer, please try the solutions suggested in this section.

If you experience	Possible Causes	Solution
Vibration or Shaking		
Check the following for proper installation or see "Using Your Washer" section.	Feet may not be in contact with the floor and locked to cabinet.	Front and rear feet must be in firm contact with floor, and washer must be level to operate properly.
	Washer may not be level.	Check floor for flexing or sagging. If flooring is uneven, a 3/4" (19 mm) piece of plywood under your washer will reduce sound. See "Level the Washer" in Installation Instructions.
	Load could be unbalanced or twisted.	Load dry items in loose heaps evenly around basket wall. Adding wet items to washer or adding more water to basket could unbalance washer. Wash smaller loads to reduce imbalance. Do not tightly pack. Avoid washing single items. Use Heavy Duty cycle for oversized, non-absorbent items such as comforters or poly-filled jackets. See "Cycle Guide" and "Using Your Washer" in this Use and Care Guide.
Noises		
Clicking or metallic noises	Objects caught in washer drain system.	Empty pockets before washing. Loose items such as coins could fall between basket and tub or may block pump. It may be necessary to call for service to remove items. It is normal to hear metal items on clothing such as metal snaps, buckles, or zippers touch against the basket.
Gurgling or humming	Washer may be draining water.	It is normal to hear the pump making a continuous humming sound with periodic gurgling or surging as final amounts of water are removed during the Drain & Spin cycles.
Humming	Load sensing may be occurring.	You may hear the hum of the sensing spins after you have started the washer. This is normal.
Water Leaks		
Check the following for proper installation:	Washer not level.	Water may splash off basket if washer is not level. Check that load is not unbalanced or tightly packed.
	Fill hoses not attached tightly.	Tighten fill-hose connection.

Troubleshooting

Before calling for service on your washer, please try the solutions suggested in this section.

If you experience	Possible Causes	Solution
Water Leaks (cont.)		
Check the following for proper installation: (cont.)	Fill hose washers.	Make sure all 4 fill hose flat washers are properly seated.
	Drain hose connection.	Pull drain hose from washer cabinet and properly secure it to drainpipe or laundry tub.
		Do not place tape over drain opening.
	Check household plumbing for leaks or clogged sink or drain.	Water can back up out of a clogged sink or drainpipe. Check all household plumbing for leaks (laundry tubs, drain pipe, water pipes, and faucets).
Washer not loaded as recommended.	Improper loading can cause basket to be out of alignment and cause water to splash off tub. See "Using Your Washer" for loading instructions.	
Washer not performing as expected		
Washer won't run or fill; washer stops working	Check for proper water supply.	Both hoses must be attached and have water flowing to inlet valve.
		Both hot and cold water faucets must be turned on.
		Check that inlet valve screens have not become clogged.
		Check for any kinks in inlet hoses, which can restrict water flow.

⚠ WARNING



Electrical Shock Hazard

Plug into a grounded 3 prong outlet.

Do not remove ground prong.

Do not use an adapter.

Do not use an extension cord.

Failure to follow these instructions can result in death, fire, or electrical shock.

	Check proper electrical supply.	Plug power cord into a grounded 3 prong outlet.
		Do not use an extension cord.
		Ensure there is power to outlet and that the polarity is correct.
		Reset a tripped circuit breaker. Replace any blown fuses. NOTE: If problems continue, contact an electrician.
	Normal washer operation.	Lid must be closed for washer to run.
		Washer will pause during certain phases of cycle. Do not interrupt cycle.
	Washer may be tightly packed.	Press START (PAUSE/UNLOCK) for 3 seconds and wait for lid to unlock. Remove several items, rearrange load evenly in basket, and add detergent. Close lid and press START.
		Do not add more than 1 or 2 additional items after cycle has started to avoid tightly packing or unbalancing.
All LEDs remain lit	Error code.	Try unplugging washer for 10 seconds and plug it back in to reset the control.
		Check for proper water supply per above.

Troubleshooting

Before calling for service on your washer, please try the solutions suggested in this section.

If you experience	Possible Causes	Solution
Washer not performing as expected (cont.)		
Washer not draining/spinning, loads are still wet, or spin light remains on (indicating that the washer was unable to pump out water within 10 minutes)	Small items may have been caught in pump or between basket and tub, which can slow draining.	Empty pockets and use garment bags for small items.
	Use a cycle with a low spin speed.	Cycles with lower spin speeds remove less water than cycles with high spin speeds. Use the recommended cycle/spin speed for your garment. To remove extra water in the load on a nonpay model, select Final Spin. Load may need to be rearranged to allow even distribution of the load in the basket.
	The washer may be tightly packed or unbalanced.	Tightly packed or unbalanced loads may not allow the washer to spin correctly, leaving the load wetter than normal. Evenly arrange the wet load for balanced spinning on a nonpay model. Select the Final Spin cycle to remove excess water. See "Using Your Washer" for loading recommendations.
	Check plumbing for correct drain hose installation. Drain hose extends into standpipe farther than 4.5" (114 mm).	Check drain hose for proper installation. Use drain hose form and securely attach to drainpipe or tub. Do not tape over drain opening. Lower drain hose if the end is higher than 96" (2.4 m) above the floor. Remove any clogs from drain hose.
	Too much detergent causing suds to slow or stop draining and spinning.	Always measure and follow detergent directions for your load. To remove extra suds on a nonpay model, select Rinse & Spin. Do not add detergent.
Dry spots on load after cycle	High-speed spins extract more moisture than traditional top-load washers.	The high spin speeds combined with airflow during the final spin can cause items near the top of the load to develop dry spots during the final spin. This is normal.
Incorrect or wrong wash or rinse temperatures	Check for proper water supply.	Make sure hot and cold inlet hoses are not reversed.
		Both hoses must be attached to both washer and faucet, and have both hot and cold water flowing to inlet valve.
		Check that inlet valve screens are not clogged.
		Remove any kinks in hoses.
Energy-saving controlled-wash temperatures.	This washer uses cooler wash and rinse water temperatures than your previous washer. This includes cooler hot and warm washes.	
Load not rinsed	Check for proper water supply.	Make sure hot and cold inlet hoses are not reversed.
		Both hoses must be attached and have water flowing to the inlet valve.
		Both hot and cold water faucets must be on.
		Inlet valve screens on washer may be clogged.
		Remove any kinks in the inlet hose.
	Using too much detergent.	The suds from too much detergent can keep washer from operating correctly. Always measure detergent and follow detergent directions based on load size and soil level.
	Washer not loaded as recommended.	The washer is less efficient at rinsing when load is tightly packed.
		Load garments in loose heaps evenly around the basket wall. Load with dry items only. Do not load above bottom of white plastic clothes guard.
Use cycle designed for the fabrics being washed.		
Add only 1 or 2 additional garments after washer has started.		
Sand, pet hair, lint, etc., on load after washing	Heavy deposits of sand, pet hair, lint, and detergent, fabric softener, or non-chlorine bleach residues may require additional rinsing.	Use Heavy Duty cycle.
Load is tangling	Washer not loaded as recommended.	See "Using Your Washer" section.
		Select a cycle with a slower wash action and spin speed; however, items will be wetter than those using a higher speed spin. See the "Cycle Guide" to match your load with the best cycle.
		Load garments in loose heaps evenly around the basket wall.
		Reduce tangling by mixing types of load items. Use the recommended cycle for the type of garments being washed.

Troubleshooting

Before calling for service on your washer, please try the solutions suggested in this section.

If you experience	Possible Causes	Solution
Washer not performing as expected (cont.)		
Not cleaning or removing stains	Washer not loaded as recommended.	Washer is less efficient at cleaning when load is tightly packed.
		Load garments in loose heaps evenly around the basket wall. Load with dry items only.
		Add only 1 or 2 additional garments after washer has started.
	Adding detergent on top of load.	Add detergent, oxi products, and color-safe bleach to the bottom of the basket before adding the load items.
	Using too much detergent.	The suds from too much detergent can keep washer from operating correctly. Always measure detergent and follow manufacturer's directions based on load size and soil level.
	Not using correct cycle for fabric type.	Use a higher soil level cycle option and warmer wash temperature to improve cleaning.
		Use Heavy Duty cycle for tough cleaning. See the "Cycle Guide" to match your load with the best cycle.
Not using dispensers.	Use dispensers to avoid chlorine bleach and fabric softener staining.	
	Load dispensers before starting a cycle.	
	Do not add products directly onto load.	
Not washing like colors together.	Wash like colors together and remove promptly after the cycle is complete to avoid dye transfer.	
Incorrect dispenser operation	Clogged dispenser.	Use only liquid chlorine bleach in the bleach dispenser. Use only fabric softener in the fabric softener dispenser.
Fabric damage	Sharp items were in pockets during wash cycle.	Empty pockets, zip zippers, and snap or hook fasteners before washing to avoid snags and tears.
	Strings and straps could have tangled.	Tie all strings and straps before starting wash load.
	Items may have been damaged before washing.	Mend rips and broken threads in seams before washing.
	Fabric damage can occur if load is tightly packed.	Load garments in loose heaps evenly around the basket wall. Load with dry items only. Load below white plastic clothes guard.
		Use cycle designed for the fabrics being washed.
		Add only 1 or 2 additional garments after washer has started.
	Liquid chlorine bleach may have been added incorrectly.	Do not pour liquid chlorine bleach directly onto load. Wipe up bleach spills.
Undiluted bleach will damage fabrics. Do not use more than recommended by manufacturer.		
Do not place load items on top of bleach dispenser when loading and unloading washer.		
Garment care instructions may not have been followed.	Always read and follow garment manufacturer's care label instructions. See the "Cycle Guide" to match your load with the best cycle.	
Odors	Monthly maintenance not done as recommended.	See "Washer Care" in "Washer Maintenance."
		Unload washer as soon as cycle is complete.
	Using too much detergent.	Be sure to measure correctly. Always follow the manufacturer's directions.
	See "Washer Care" section.	
Lid Locked LED is flashing	The lid is not closed.	Close the lid and press START. The washer will not start or fill with the lid open.
	A cycle was stopped or paused using the Start (Pause/Unlock) button.	The washer may still be spinning. The lid will not unlock until the basket has stopped spinning. This may take several minutes if washing large loads or heavy fabrics.
Single-dose laundry packet not dissolving	Adding laundry packet incorrectly.	Be sure laundry packet is added to washer basket before adding clothes. Do not add packet to dispenser. Follow the manufacturer's instructions to avoid damage to your garments.

WHIRLPOOL® COMMERCIAL LAUNDRY LIMITED WARRANTY

IF YOU NEED SERVICE:

Contact your authorized Whirlpool® Commercial Laundry distributor. To locate your authorized Whirlpool® Commercial Laundry distributor, call:
1-800-662-3587, or for web inquiries, visit www.WhirlpoolCommercialLaundry.com.

For written correspondence:

**Whirlpool® Commercial Laundry Service Department
2000 N M 63
Benton Harbor, Michigan 49022-2632 USA**

90 DAY LIMITED WARRANTY

WHAT IS COVERED

90 DAY LIMITED WARRANTY (PARTS AND LABOR)

For 90 days from the original date of purchase, when this commercial appliance is installed, maintained, and operated according to the instructions attached to or furnished with the product, Whirlpool Corporation (hereafter "Whirlpool") will pay for factory specified replacement parts and repair labor to correct defects in materials or workmanship that existed when this commercial appliance was purchased.

TWO YEAR LIMITED WARRANTY (PARTS ONLY)

For the first two years from the original date of purchase, when this commercial appliance is installed, maintained, and operated according to the instructions attached to or furnished with the product, Whirlpool will pay for factory specified replacement parts to correct defects in materials or workmanship that existed when this commercial appliance was purchased.

YOUR SOLE AND EXCLUSIVE REMEDY UNDER THIS LIMITED WARRANTY SHALL BE PRODUCT REPAIR AS PROVIDED HEREIN. Whirlpool recommends that you use an "in network" service provider to diagnose and repair your Commercial Laundry product. Whirlpool will not be responsible under this warranty to provide additional replacement parts as a result of incorrect diagnosis or repair by an "out of network" service company. This limited warranty is valid in the United States or Canada and applies only when the commercial appliance is used in the country in which it was purchased. This limited warranty is effective from the date of the original consumer purchase. Proof of original purchase date is required to obtain service under this limited warranty.

WHAT IS NOT COVERED

1. All other costs including labor, transportation, shipping, or custom duties for covered parts.
2. Factory specified replacement parts if this commercial appliance is used for other than normal, commercial use or when it is used in a manner that is inconsistent to published user or operator instructions and/or installation instructions.
3. Service calls to correct the installation of your commercial appliance, to instruct you on how to use your commercial appliance, to replace or repair house fuses, or to correct external wiring or plumbing.
4. Service calls to repair or replace appliance light bulbs, air filters, or water filters. Consumable parts are excluded from warranty coverage.
5. Damage resulting from improper handling of product during delivery, theft, accident, alteration, misuse, abuse, fire, flood, acts of God, improper installation, installation not in accordance with local electrical or plumbing codes, or use of products not approved by Whirlpool.
6. Pick up and delivery. This commercial appliance is designed to be repaired on location.
7. Repairs to parts or systems resulting from unauthorized modifications made to the commercial appliance.
8. The removal and reinstallation of your commercial appliance if it is installed in an inaccessible location or is not installed in accordance with published installation instructions.
9. Damage resulting from exposure to chemicals.
10. Changes to the building, room, or location needed in order to make the commercial appliance operate correctly.
11. Factory specified replacement parts on commercial appliances with original model/serial numbers that have been removed, altered, or cannot be easily determined.
12. Discoloration, rust, or oxidation of stainless steel surfaces.
13. Factory specified replacement parts as a result of incorrect diagnosis or repair by an "out of network" service company.

The cost of repair or replacement under these excluded circumstances shall be borne by the customer.

DISCLAIMER OF IMPLIED WARRANTIES

IMPLIED WARRANTIES, INCLUDING ANY IMPLIED WARRANTY OF MERCHANTABILITY OR IMPLIED WARRANTY OF FITNESS FOR A PARTICULAR PURPOSE, ARE LIMITED TO TWO YEARS OR THE SHORTEST PERIOD ALLOWED BY LAW. Some states and provinces do not allow limitations on the duration of implied warranties of merchantability or fitness, so this limitation may not apply to you. This warranty gives you specific legal rights, and you also may have other rights that vary from state to state or province to province.

DISCLAIMER OF REPRESENTATIONS OUTSIDE OF WARRANTY

Whirlpool makes no representations about the quality, durability, or need for service or repair of this major appliance other than the representations contained in this Warranty. If you want a longer or more comprehensive warranty than the limited warranty that comes with this major appliance, you should ask Whirlpool or your retailer about buying an extended warranty.

LIMITATION OF REMEDIES; EXCLUSION OF INCIDENTAL AND CONSEQUENTIAL DAMAGES

YOUR SOLE AND EXCLUSIVE REMEDY UNDER THIS LIMITED WARRANTY SHALL BE PRODUCT REPAIR AS PROVIDED HEREIN. WHIRLPOOL SHALL NOT BE LIABLE FOR INCIDENTAL OR CONSEQUENTIAL DAMAGES. Some states and provinces do not allow the exclusion or limitation of incidental or consequential damages, so these limitations and exclusions may not apply to you. This warranty gives you specific legal rights, and you also may have other rights that vary from state to state or province to province.

Notes

Assistance or Service

Before calling for assistance or service, please check "Troubleshooting" or visit www.whirlpool.com/help. It may save you the cost of a service call. If you still need help, follow the instructions below. When calling, please know the purchase date and the complete model and serial number of your appliance. This information will help us to better respond to your request.

If you need replacement parts or to order accessories

We recommend that you use only FSP® Factory Specified Parts. These parts will fit right and work right because they are made with the same precision used to build every new WHIRLPOOL® appliance.

To locate FSP® replacement parts or accessories go to www.whirlpoolpartsonline.com.

Questions? Call us toll free at **1-866-698-2538** or in Canada call **1-800-688-2002**.

Our consultants provide assistance with

In the U.S.A.

- Features and specifications on our full line of appliances.
- Installation information.
- Specialized customer assistance (Spanish speaking, hearing impaired, limited vision, etc.).

In the U.S.A. and Canada

- Use and maintenance procedures.
- Accessory and repair parts sales.
- Referrals to local dealers, repair parts distributors, and service companies. Whirlpool designated service technicians are trained to fulfill the product warranty and provide after-warranty service, anywhere in the United States and Canada.

You can write with any questions or concerns at:

Whirlpool Brand Appliances
Customer eXperience Center
553 Benson Road
Benton Harbor, MI 49022-2692
1-866-698-2538

Whirlpool Brand Appliances
Customer eXperience Centre
Unit 200-6750 Century Ave
Mississauga, Ontario L5N 0B7
1-800-688-2002

Please include a daytime phone number in your correspondence.

Assistance ou Service

Avant de faire un appel pour obtenir de l'assistance ou un entretien, vérifiez la section "Dépannage" ou consulter www.whirlpool.com/help. Cette vérification peut vous faire économiser le coût d'une visite de réparation.

Si vous avez encore besoin d'aide, suivez les instructions ci-dessous.

Lors d'un appel, garder à portée de main la date d'achat et les numéros de modèle et de série de votre appareil. Ces renseignements nous aideront à mieux répondre à votre demande.

Pour commander des pièces de rechange ou des accessoires

Pour commander des pièces de rechange, nous vous recommandons d'utiliser seulement des pièces spécifiées par l'usine. Ces pièces conviendront et fonctionneront bien parce qu'elles sont fabriquées selon les mêmes spécifications précises utilisées pour construire chaque nouvel appareil WHIRLPOOL®.

Pour trouver des pièces de rechange FSP® ou des accessoires, visiter le www.whirlpool.ca.

Des questions? Composer le numéro sans frais **1-800-688-2002**.

Nos consultants fournissent l'assistance pour :

- Procédés d'utilisation et d'entretien.
- Vente d'accessoires et de pièces de rechange.
- Références aux concessionnaires, compagnies de service de réparation et distributeurs de pièces de rechange locaux. Les techniciens de service désignés par Whirlpool sont formés pour remplir la garantie des produits et fournir un service après la garantie, partout au Canada.

Pour plus d'assistance

Vous pouvez nous soumettre toute question ou tout problème en écrivant à l'adresse ci-dessous :

Whirlpool Brand Appliances
Centre pour l'eXpérience de la clientèle
Unit 200-6750 Century Ave
Mississauga, Ontario L5N 0B7
1-800-688-2002

Dans votre correspondance, veuillez indiquer un numéro de téléphone où nous pouvons vous joindre dans la journée.