

5" Industrial PDA

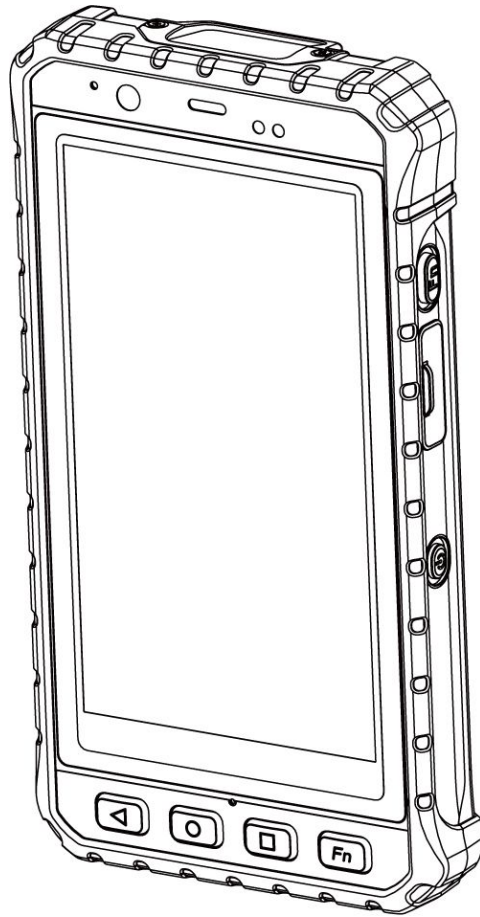

E500RM8 Series

User Guide

Version 1.0

Preface

Copyright Notice

No part of this document may be reproduced, copied, translated, or transmitted in any form or by any means, electronic or mechanical, for any purpose, without the prior written permission of the original manufacturer.

Trademark Acknowledgement

Brand and product names are trademarks or registered trademarks of their respective owners.

Disclaimer

We reserve the right to make changes, without notice, to any product, including circuits and/or software described or contained in this manual in order to improve design and/or performance. We assume no responsibility or liability for the use of the described product(s) conveys no license or title under any patent, copyright, or masks work rights to these products, and make no representations or warranties that these products are free from patent, copyright, or mask work right infringement, unless otherwise specified. Applications that are described in this manual are for illustration purposes only. We make no representation or guarantee that such application will be suitable for the specified use without further testing or modification.

Warranty

Our warranty guarantees that each of its products will be free from material and workmanship defects for a period of one year from the invoice date. If the customer discovers a defect, we will, at his/her option, repair or replace the defective product at no charge to the customer, provide it is returned during the warranty period of one year, with transportation charges prepaid. The returned product must be properly packaged in its original packaging to obtain warranty service. If the serial number and the product shipping data differ by over 30 days, the in-warranty service will be made according to the shipping date. In the serial numbers the third and fourth two digits give the year of manufacture, and the fifth digit means the month (e. g., with A for October, B for November and C for December).

For example, the serial number 1W16Axxxxxxx means October of year 2016.

Customer Service

We provide a service guide for any problem by the following steps: First, visit the website of our distributor to find the update information about the product. Second, contact with your distributor, sales representative, or our customer service center for technical support if you need additional assistance.

You may need the following information ready before you call:

- Product serial number
- Software (OS, version, application software, etc.)
- Description of complete problem
- The exact wording of any error messages

In addition, free technical support is available from our engineers every business day. We are always ready to give advice on application requirements or specific information on the installation and operation of any of our products.

Advisory Conventions

Four types of advisories are used throughout the user manual to provide helpful information or to alert you to the potential for hardware damage or personal injury. These are Notes, Important, Cautions, and Warnings. The following is an example of each type of advisory.



NOTE

A note is used to emphasize helpful information.



IMPORTANT

An important note indicates information that is important for you to know.



CAUTION

A Caution alert indicates potential damage to hardware and explains how to avoid the potential problem.



WARNING!

An Electrical Shock Warning indicates the potential harm from electrical hazards and how to avoid the potential problem.

Read Me First

Safety Information

Follow and adhere to all warnings and instructions in this manual. For your safety, please read all safety and operating instructions before using the product. Keep this manual for future reference.



General Product Safety **Sécurité générale des produits**

This product should not be used near water such as bathtubs, sinks, swimming pools, wet basement, etc.

Ce produit ne doit pas être utilisé près de l'eau comme les baignoires, les éviers, les piscines, les sous-sols humides, etc.

Do not block any ventilation openings. Do not place the product against a wall or in an enclosed space as doing so might impede the flow of cooling air.

Ne pas bloquer les ouvertures de ventilation. Ne pas placer le produit contre un mur ou dans un espace clos de façon à entraver la circulation de l'air de refroidissement.

Do not place the product near any heat sources such as radiators, warm air intakes, stoves or other heat-generating devices (including amplifiers or other heat producing equipment).

Ne pas placer le produit près d'une source de chaleur comme des radiateurs, les arrivées d'air chaud, poêles ou autres produits générant de la chaleur (y compris les amplificateurs ou autre équipement produisant de la chaleur.)

Do not disregard the safety that a polarized or grounded connection can provide. A polarized connection consists of two plugs, one of which is larger than the other. A grounded connection has two blades and a third one that is grounded. If the main plug provided cannot be inserted into your outlet, consult an electrician to replace your obsolete outlet.

Ne pas ignorer la sécurité qu'une prise polarisée ou une prise de terre peut prévoir. Une prise polarisée se compose de deux fiches, dont l'une est plus large que l'autre. Une prise de terre possède deux lames et une troisième qui est la terre. Si la fiche principale fournie ne peut être insérée dans votre prise, consultez un électricien pour remplacer votre prise obsolète.

Protect the power cord from being crushed or pinched, particularly in the area of the plugs, any receptacles used, and the point of exit from the apparatus. Do not break off the ground pin of the power cord.

Empêcher le cordon d'alimentation d'être écrasé ou pincé, en particulier dans les zones de prises, des containers utilisés, et du point de sortie de l'appareil. Ne pas casser la broche de terre du cordon d'alimentation.

Use only accessories specified by the manufacturer.

Utiliser uniquement les accessoires spécifiés par le fabricant.

Use only with its transport carriage, stand, tripod, console or table specified by the manufacturer or sold with the product. When using a carriage, move the carriage assembly with the product carefully to avoid damage from falling over.

Utiliser uniquement avec son chariot de transport, support, trépied, console ou table spécifiés par le fabricant ou vendu avec le produit. Lors de l'utilisation d'un charriot, déplacez l'ensemble chariot avec le produit avec soin pour éviter tout dommage de chute.

Unplug this apparatus during lightning storms or when it is not being used for long periods.

Débrancher cet appareil durant les orages ou lorsqu'il n'est pas utilisé pendant de longues périodes.

Refer all servicing to qualified service personnel. A technical intervention is required when the apparatus has been damaged in any way, for example if the power cord or plug is damaged, liquid has been spilled or objects have fallen inside the unit, if the product has been exposed to rain or moisture, if it does not operate normally or if it has been dropped.

Confier toute réparation à du personnel qualifié. Une intervention technique est nécessaire lorsque l'appareil a été endommagé de quelque façon, par exemple si le cordon d'alimentation ou la fiche est endommagé, du liquide a été renversé ou des objets sont tombés à l'intérieur de l'unité, si le produit a été exposé à la pluie ou à l'humidité, s'il ne fonctionne pas normalement ou s'il a été jeté.



Precaution on Battery Pack
Précaution avec le bloc-pile

Do Not Expose the Battery Pack to Excessive Heat, or Extreme Heat (Near Fire, in Direct Sunlight for example)
Generation of heat, ignition or rupture may result

Ne pas exposer le bloc-pile à une Chaleur Excessive, ou une Chaleur Extrême (Près d'un feu, sous la lumière du soleil par exemple) Une production de chaleur, l'amorçage ou la rupture peuvent être occasionnés

Do Not Disassemble, Modify, or Insert Sharp Objects Into the Battery Pack. Electrolyte leakage, generation of heat, ignition or rupture may result.

Ne pas démonter, modifier, ou insérer des objets pointus à l'intérieur du bloc-pile. Une fuite d'électrolyte, la génération de chaleur, l'amorçage ou la rupture peuvent être occasionnés.

Do Not Short the Positive (+) and Negative (-) Terminals of the Battery. Generation of heat, ignition or rupture may result. When carrying or storing the device, do not place the battery pack together with articles that may contact electricity.

Ne pas court-circuiter les bornes Positive (+) et Négative (-) de la pile, la génération de chaleur, l'amorçage ou la rupture peuvent être occasionnés. Lors du transport et du rangement de l'appareil, ne pas placer le bloc-pile en même temps que des articles pouvant créer un contact électrique.

Do Not Apply Shocks to the Battery by Dropping It or Applying Strong Pressure to It. Electrolyte leakage, generation of heat, ignition or rupture of battery may occurs.

Ne pas faire subir de choc à la pile en la laissant tomber ou en appliquant une forte pression dessus. Une fuite d'électrolyte, la génération de chaleur, l'amorçage ou la rupture peuvent être occasionnés.

Do Not Charge the Battery Other Than Methods Those Specified In This Manual. If the battery is not charged using one of the specified methods, electrolyte leakage, generation of heat, ignition or rupture may result.

Ne pas charger la pile par d'autres méthodes que celles spécifiées dans ce manuel. Si la pile n'est pas chargée en utilisant l'une des méthodes spécifiées, une fuite d'électrolyte, la génération de chaleur, l'amorçage ou la rupture peuvent être occasionnés.

When the Battery Pack Has Deteriorated, Replace It with a New Battery. Continued use of a damaged battery pack may result in heat generation, ignition or battery rupture.

Lorsque la pile est détériorée, la remplacer par une nouvelle pile. L'utilisation continue d'une pile endommagée peut occasionner une génération de chaleur, l'amorçage ou la rupture de la pile.

Do Not Use the Battery Pack With Any Other Products. The battery pack is rechargeable and is only designed for this specific product. If it is used with a product other than the specified product, electrolyte leakage, generation of heat, ignition or rupture may result.

Ne pas utiliser avec un autre produit La batterie est rechargeable et a été conçue pour un produit spécifique. Si elle est utilisée sur un produit différent de celui pour lequel elle a été conçue, des pertes d'électrolytes et une production de chaleur sont possibles, elle risque également de prendre feu ou de casser.

Do Not Use This Product With Battery Other Than the One Specified.

Ne pas utiliser ce produit avec une batterie autre que celle spécifiée

Exposure to Radio Use

E500RM8 is equipped with Bluetooth, Wi-Fi and Cellular modem radio. In some situations or areas, user may be required to turn off the radios. For example:

- User's needs to turn the phone OFF when in an area posted "**TURN OFF RADIO SIGNAL.**" to avoid interfering with blasting operations.
- User needs to turn OFF the radio signal in health care facilities. Hospitals or health care facilities may be using devices that sensitive to Radio Frequency energy.
- Aviation authority regulations prohibit user from using phone while in the aircraft.

In order to prevent the handheld from emitting radio signals, do the following steps:

- To turn off the device:
Press and hold the power button to display the Phone Options menu for 3 sec then tap the **POWER OFF**
- To set the device into airplane mode:
Press and hold the power button to display the Phone Options menu for 3 sec then tap **AIRPLANE MODE**
- To turn off the Communication options e.g. Bluetooth, Wi-Fi, cellular modem radio:

Select **MENU** , tap **SETTINGS** , and then tap **WIRELESS & NETWORKS**.

If any radios are on, tap them to uncheck all the radios' checkboxes in the devices.

on.

RF Exposure Information

This PDA meets the government's requirement for exposure to radio waves. This PDA is designed and manufactured not to exceed the emission limits for exposure to radio frequency (RF) energy set by the Federal Communications Commission of the U.S. Government. The exposure standard for wireless devices employs a unit of measurement known as the Specific Absorption Rate (SAR). The SAR limit set by the FCC is 1.6W/Kg. Test for SAR are conducted using standard operating positions accepted by the FCC with the device transmitting at its highest certified power level in all tested frequency bands.

Although SAR is determined at the highest certified power level, the actual SAR level of the device while operating can be well below the maximum value. This is because the PDA is designed to operate at multiple power levels so as to use only the power required to reach the network.

In general, the closer user to a wireless base station antenna, the lower the power output. For body worn operation, this PDA has been tested and meets the FCC RF exposure guidelines for use with an accessory that contains no metal and the positions of the handset minimum of 1.5 cm from the body. User of other enhancements may not ensure compliance with FCC RF exposure guidelines. If user do not use a body-worn accessory and are not holding the PDA at the ear, position the handset a minimum of 1.5 cm from your body when the device is switched

Electrostatic Discharge



CAUTION

Please follow proper electrostatic discharge precaution to prevent static damage that can harm electronic components inside your device.

Driving



Using mobile device or accessories while driving may cause distraction and can be illegal in some areas where you drive. Please obey the laws and regulations on the use of mobile device

Handling and Maintenance

Follow and adhere to all warnings and instructions in this manual. For the longevity of the product usage, please read all operating instructions before using the product. Keep this manual for future reference.



General Guideline
Guide Général

Keep the product at least 13 cm (5 inches) away from electrical appliances that can generate a strong magnetic field such as TV, refrigerator, motor, or a large audio speaker.

Garder le produit au moins à 13 cm (5 pouces) de distance des appareils électriques qui peuvent générer un fort champ magnétique comme une télévision, un réfrigérateur, un moteur, ou un important haut-parleur.

Do not place heavy objects on top of the tablet computer as this may damage the display.

Ne pas placer d'objets lourds sur le dessus de l'ordinateur tablette cela peut endommager l'écran.

The screen surface can be easily scratched. Use with care. Do not use paper towels to clean the display but use the included cleaning cloth. Avoid touching it with a pen or pencil.

La surface de l'écran peut être facilement rayée. Utiliser avec précaution. Ne pas utiliser de serviette en papier pour nettoyer l'écran mais utiliser le chiffon de nettoyage inclus. Éviter de toucher avec un stylo ou un crayon.

To maximize the life of the backlight in the display, allow backlight to automatically turn off as a result of power management. Avoid using a screen saver or other software that prevents the power management from working.

Pour maximiser la durée de vie du rétroéclairage de l'écran, autoriser le rétroéclairage résultant de la gestion de l'alimentation. Éviter d'utiliser un économiseur d'écran ou un autre logiciel empêchant la gestion de l'alimentation de fonctionner.



Cleaning Guideline **Guide de nettoyage**

Use a soft cloth moistened with water or a non-alkaline detergent to wipe the exterior of the product.

Utiliser un chiffon doux humidifié avec de l'eau ou un détergeant non alcalin pour essuyer l'extérieur du produit.

Gently wipe the display with a soft, lint-free cloth. Do not use alcohol or detergent on the product.

Essuyer délicatement l'écran avec un chiffon doux non pelucheux. Ne pas utiliser d'alcool ou un détergent sur le produit.



Touchscreen Guideline **Guide de l'écran tactile**

Use your finger or the stylus on the display. Using sharp or metallic object may cause scratches and damage the display, thereby causing errors.

Utiliser votre doigt ou le stylet sur l'écran. L'utilisation d'un objet pointu ou métallique peut provoquer des rayures.

Use a soft cloth to remove dirt on the display. The touchscreen surface has a special protective coating that prevents dirt from sticking to it. Not using a soft cloth may cause damage to the special protective coating on the touchscreen surface. To clean off hard to remove dirt, blow some steam on the particular area and gently wipe away using a soft cloth.

Utiliser un chiffon doux pour enlever la poussière sur l'écran. La surface de l'écran tactile a un revêtement protecteur spécial empêchant la saleté de se coller à lui. Ne pas utiliser un chiffon doux peut endommager le revêtement spécial sur la surface de l'écran tactile. Pour nettoyer les saletés plus difficiles à enlever, souffler de la buée sur la zone particulière et essuyer doucement avec un chiffon doux.





Do not use excessive force on the display. Avoid placing objects on top of the display as this may cause the glass to break.

Ne pas utiliser une force excessive sur l'écran. Éviter de placer des objets au dessus de l'écran cela pourrait provoquer une cassure du verre.

When there is a noticeable discrepancy in the operation of the touchscreen function (your touch does not correlate to the proper location on the screen), recalibrate the touchscreen display.

Lorsqu'il y a un écart sensible dans le fonctionnement de l'écran tactile (votre contact ne correspond pas à la bonne position sur l'écran), recalibrer l'écran tactile.

Important Information

Countries/ Area	Symbol	This equipment complies with essential requirements of:
European Union 		Electromagnetic Compatibility Directive(2014/30/EU) Low Voltage Directive (2014/35/EU) Radio and Telecommunication Terminal Equipment (R&TTE) Directive (2014/53/EU)
USA 		FCC Part 15 Subpart B Regulations Class B
CANADA 	ICES-003	ICES-003 — Information Technology Equipment (Including Digital Apparatus)

EC Declaration of Conformity



This equipment is in conformity with the requirement of the following EU legislations and harmonized standards. Product also complies with the Council directions.

Electromagnetic Compatibility Directive (2014/30/EU)

- EN55032: 2012/AC:2013
- EN55024: 2010
- EN610000-3-2: 2014/EN610000-3-3: 2013

Low Voltage Directive (2014/35/EU)

- EN 60950-1:2006/A11:2009/A1:2010/A12:2011/ A2:2013

The Radio Equipment Directive (2014/53/EU)

- ETSI EN 300 328 V1.9.1(2015-02)
- ETSI EN 301 489-1 V1.9.2(2011-09)/ETSI EN 301 489-3 V1.6.1(2013-08)/ETSI EN 301 489-17 V2.2.1(2012-09)
- ETSI EN 300 440-1 V1.6.1(2010-08)/ETSI EN 300 440-2 V1.4.1(2010-08)
- EN 50566:2013/AC:2014/EN62479: 2010

Hereby, Winmate Inc. declares that the radio equipment type (Rugged PDA E500RM8) is in compliance with Directive 2014/53/EU.

The full text of the EU declaration of conformity is available at the following internet address: 

<http://www.winmate.com.tw/>



Federal Communications Commission Radio Frequency Interface Statement



This mobile phone complies with part 15 of the FCC Rules..

Operation is subject to the following two conditions:

- This device may not cause harmful interference.
- This device must accept any interference received, including interference that may cause undesired operation.

This mobile phone has been tested and found to comply with the limits for a Class B digital device, pursuant to Part 15 of the FCC Rules. These limits are designed to provide reasonable protection against harmful interference in a residential installation. This equipment generates, uses and can radiated radio frequency energy and, if not installed and used in accordance with the instructions, may cause harmful interference to radio communications. However, there is no guarantee that interference will not occur in a particular installation. If this equipment does cause harmful interference to radio or television reception, which can be determined by turning the equipment off and on, the user is encouraged to try to correct the interference by one or more of the following measures:

-Reorient or relocate the receiving antenna.

-Increase the separation between the equipment and receiver.

-Connect the equipment into an outlet on a circuit different from that to which the receiver is connected.

-Consult the dealer or an experienced radio/TV technician for help.

FCC Note:

Caution: Changes or modifications not expressly approved by the party responsible for compliance could void the user's authority to operate the equipment.

RF exposure information (SAR)

This phone is designed and manufactured not to exceed the emission limits for exposure to radio frequency (RF) energy set by the Federal Communications Commission of the United States. During SAR testing, this device was set to transmit at its highest certified power level in all tested frequency bands, and placed in positions that simulate RF exposure in usage against the head with no separation, and near the body with the separation of 10 mm. Although the SAR is determined at the highest certified power level, the actual SAR level of the device while operating can be well below the maximum value. This is because the phone is designed to operate at multiple power levels so as to use only the power required to reach the network. In general, the closer you are to a wireless base station antenna, the lower the power output.

The exposure standard for wireless devices employing a unit of measurement is known as the Specific Absorption Rate, or SAR. The SAR limit set by the FCC is 1.6W/kg.

This device is complied with SAR for general population /uncontrolled exposure limits in ANSI/IEEE C95.1-1992 and had been tested in accordance with the measurement methods and procedures specified in

IEEE1528. This device has been tested and meets the FCC RF exposure guidelines when tested with the device directly contacted to the body.

The FCC has granted an Equipment Authorization for this model phone with all reported SAR levels evaluated as in compliance with the FCC RF exposure guidelines. SAR information on this model phone is on file with the FCC and can be found under the Display Grant section of www.fcc.gov/oet/ea/fccid after searching on FCC ID: PX9500

For this device, the highest reported SAR value for usage near the body is **0.305** W/kg. While there may be differences between the SAR levels of various phones and at various positions, they all meet the government requirements. SAR compliance for body-worn operation is based on a separation distance of 0 mm between the unit and the human body.

IC NOTICE TO CANADIAN USERS

This device complies with Industry Canada license-exempt RSS standard(s). Operation is subject to the following two conditions: (1) This device may not cause interference, and (2) This device must accept any interference, including interference that may cause undesired operation of the device. This device complies with RSS-247 of Industry Canada. Operation is subject to the condition that this device does not cause harmful interference. This Class B digital apparatus complies with Canadian ICES-003 (Cet appareil numérique de la Classe B conforme à la norme NMB-003 du Canada).

The SAR limit of CANADA (IC) is 1.6 W/kg averaged over one gram of tissue. Device has also been tested against this SAR limit. The highest SAR value reported under this standard during product certification when properly near the body is 0.472W/kg.

Le présent appareil est conforme aux CNR d'Industrie Canada applicables aux appareils radio exempts de licence. L'exploitation est autorisée aux deux conditions suivantes : (1) l'appareil ne doit pas produire de brouillage, et (2) l'utilisateur de l'appareil doit accepter tout brouillage radioélectrique subi, même si le brouillage est susceptible d'en compromettre le fonctionnement.

la limite de sar du canada (ic) est de 1,6 w / kg en moyenne pour un gramme de tissu. dispositif a également été testé contre cette limite de sar. la valeur de r - s en vertu de cette norme plus élevée au cours de la certification de produits déclarés correctement 0.472w/kg près du corps

Contents

PREFACE	I
READ ME FIRST	III
SAFETY INFORMATION.....	III
EXPOSURE TO RADIO USE.....	VI
RF EXPOSURE INFORMATION.....	VII
ELECTROSTATIC DISCHARGE.....	VII
DRIVING.....	VII
HANDLING AND MAINTENANCE.....	VII
ABOUT THIS USER GUIDE	12
CHAPTER 1 GETTING STARTED	12
INTRODUCTION.....	12
PRODUCT FEATURES.....	12
UNPACKING.....	12
DESCRIPTION OF PARTS.....	12
<i>Front View</i>	12
<i>Rear View</i>	12
<i>Dimensions</i>	12
GETTING STARTED.....	12
<i>SD Card Installation</i>	12
<i>Battery Installation</i>	12
<i>Charging the Battery</i>	12
TURNING ON AND OFF THE DEVICE.....	12
<i>Turning ON</i>	12
<i>Turning OFF</i>	12
RESETTING TO FACTORY DEFAULTS.....	12
CHAPTER 2 USING THE E500RM8	12
USING THE TOUCH SCREEN.....	12
WAKING UP THE PHONE.....	12
USING THE HOME SCREEN.....	12
<i>Personalizing Home Screen</i>	12
<i>Viewing other parts of the Home Screen</i>	12
STATUS AND NOTIFICATION ICONS.....	12
<i>Notification Icons</i>	12
<i>Status Icons</i>	12
USING THE ON-SCREEN KEYBOARD.....	12
<i>Entering Text</i>	12
<i>Editing Text</i>	12
DISPLAY SETTINGS.....	12
AUDIO PROFILE SETTINGS.....	12
<i>Sounds Settings</i>	12
<i>Adjusting Volume</i>	12
LANGUAGE AND KEYBOARD SETTINGS.....	12
<i>Changing the Keyboard Language</i>	12
ABOUT PHONE.....	12
CHAPTER 3 USING WINMATE® HOME MANAGER (WHM)	12
HOW TO LOCK APPLICATIONS.....	12

HOW TO UNLOCK APPLICATIONS.....	12
HOW TO CHANGE PASSWORD.....	12
CHAPTER 4 CONNECTING TO NETWORK AND DEVICES.....	12
CONNECTING TO WI-FI NETWORKS.....	12
<i>Turning ON the Wi-Fi and Connecting to Wi-Fi networks.....</i>	12
<i>Adding Wi-Fi Network.....</i>	12
CONNECTING TO BLUETOOTH DEVICES.....	12
<i>Turning Bluetooth ON or OFF.....</i>	12
<i>Connecting to Bluetooth Device.....</i>	12
<i>Disconnecting Bluetooth Device.....</i>	12
CONNECTING TO COMPUTER VIA USB.....	12
<i>USB Computer Connection.....</i>	12
<i>USB Debugging Settings.....</i>	12
CHAPTER 5 USING CAMERA.....	12
CAPTURING PHOTOS OR VIDEO.....	12
<i>Opening Camera.....</i>	12
<i>Taking pictures.....</i>	12
<i>Switching between front and rear cameras.....</i>	12
<i>Viewing pictures.....</i>	12
<i>Shooting videos.....</i>	12
<i>Opening the Gallery.....</i>	12
CHAPTER 6 CAPTURING DATA.....	12
USING BARCODE READER.....	12
<i>Location.....</i>	12
<i>Android Winmate® Data Collection (WDC).....</i>	12
<i>Where To Find WDC?.....</i>	12
<i>How to Turn On/Off the Power of Barcode Reader.....</i>	12
<i>How to change the symbologies of Barcode.....</i>	12
<i>How to add command to my output of the barcode.....</i>	12
<i>How to change the scan type for the Barcode Reader.....</i>	12
<i>How to change the setting of the application WDC or reset the setting back to default.....</i>	12
<i>Scanning the barcode.....</i>	12
<i>Scanning Tips and Considerations.....</i>	12
USING SMART CARD READER.....	12
<i>Location.....</i>	12
<i>How to Use Smart Card Reader.....</i>	12
<i>Smart Card Reader SDK.....</i>	12
USING FINGERPRINT SCANNER.....	12
<i>Location.....</i>	12
CHAPTER 7 ACCESSORIES.....	12
STANDARD ACCESSORIES.....	12
<i>Power Adapter.....</i>	12
<i>Micro USB Cable.....</i>	12
<i>Micro SD Card.....</i>	12
<i>Hand Strap.....</i>	12
OPTIONAL ACCESSORIES.....	12
<i>Two Slot Battery Charger.....</i>	12
<i>Micro USB Host Cable (OTG Cable).....</i>	12

<i>Mobile Printer</i>	12
APPENDIX A: PRODUCT SPECIFICATIONS	12
APPENDIX B: ORDERING INFORMATION	12
APPENDIX C: SOFTWARE DEVELOPMENT KIT	12
APPENDIX D OS IMAGE UPDATE	12

About This User Guide

This User Guide provides information about using the Winmate® E500RM8 and accessories.



NOT

E

Some pictures in this guide are samples and can differ from actual product.

Documentation Set

The documentation set for the E500RM8 provides information for specific user needs, and includes:

- **E500RM8 Quick Start Guide** - describes how to get the E500RM8 up and running.
- **E500RM8 User Guide** – contains detailed description on how to use the E500RM8, its components and features.

Chapter Descriptions

[Chapter 1, Getting Started](#) provides basic instructions on how to use E500RM8, including SD card and battery installation, powering on and resetting E500RM8.

[Chapter 2, Using the E500RM8](#) provides basic instructions on using the E500RM8.

[Chapter 3, Using Winmate Home Manager](#) explains how to use WHM to lock the launcher.

[Chapter 4, Connecting to Network and Devices](#) explains how to connect E500RM8 to networks, Bluetooth devices, and computer.

[Chapter 5, Using Camera](#) provides instructions on how to use camera on E500RM8.

[Chapter 6, Capturing Data](#) provides information on how to use Barcode Reader, Smartcard Reader and Fingerprint Scanner that might be present in E500RM8.

[Chapter 7, Accessories](#) describes the available accessories and how to use them with the E500RM8.

Chapter 1 Getting Started

This chapter tells you information about Winmate® E500RM8 PDA, its highlighted features, and provides basic instructions for using the E500RM8, including powering on and resetting the E500RM8.

Introduction

Thank you for purchasing Winmate® E500RM8 Industrial PDA. Winmate® E500RM8 Industrial PDA is an enterprise-class PDA with powerful mobile computing solution. The E500RM8 PDA brings a new level of flexibility, functionality and rugged design to pocket-sized mobile devices, providing task workers and managers with the power to streamline business processes, increasing productivity and improving customer service.

The E500RM8 packs WLAN, Bluetooth, and GPS function - all into a single device. With great multiple wireless communicate design, this product will be applicable to mobile worker, business application, and IT requirements.

Product Features

Wimate® E500RM8 Industrial PDA features:





- ARM® Cortex™-A53 Octa-core 1.3 Ghz
- Memory includes 2 GB RAM LPDDR3 and 16 GB eMMC
- Support extra Micro SD card and maxima to 32 GB
- 5.0-inch capacitive multi-touch display offers 1280 x 720 pixel resolution
- Bluetooth 4.0 Support BLE mode +wide-band speech
- Wi-Fi 802.11 b/g/n
- Built-in GPS module supports GPS, GLONASS and BeiDou, LNA on board with passive ANT
- Dual cameras include 2MP front side and 8MP rear side
- Support 1D/2D Barcode Reader, Fingerprint Scanner, and Smart Card Reader as option.

Unpacking

If any of the following items are missing or damaged, contact us.

Standard packing list includes:

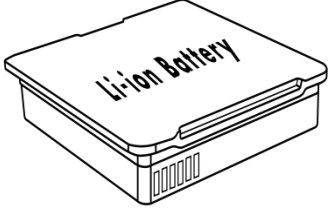
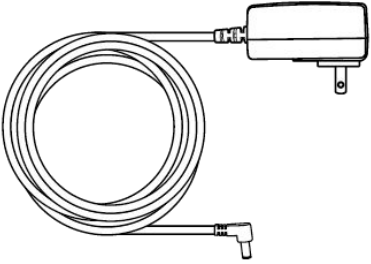
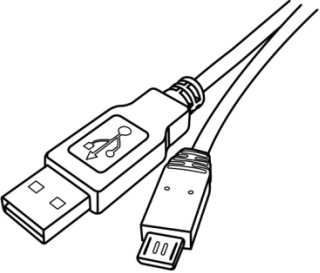
E500RM8 User Guide

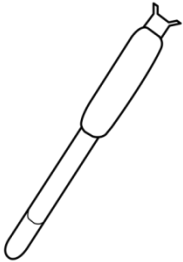
		
<p>E500RM8</p>	<p>Quick Start Guide (Hardcopy)</p>	<p>Li-ion Battery</p>
		
<p>*Adapter Input: AC 100-240V 50/60 Hz Output : 5V-2A</p>	<p>Micro USB Cable</p>	<p>Micro SD Card (4GB)</p>
		
<p>Hand Strap</p>		

** Adapter socket varies by country and region. E500RM8 will be shipped with the socket according to your order.*



Your package may include optional accessories based on your order. To see the list of available accessories and its specifications, refer to [Chapter 7](#) of this User Guide.

Description of Parts

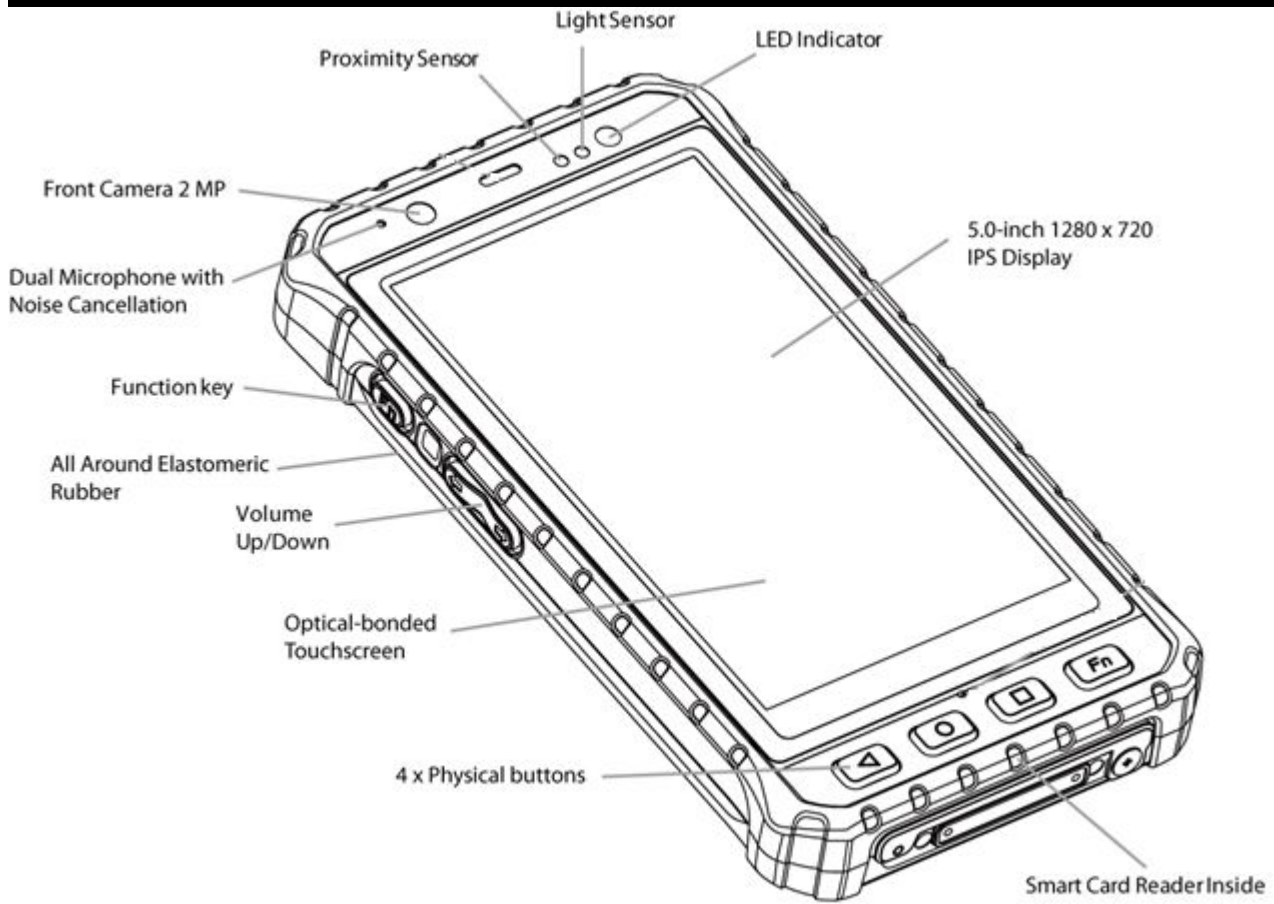
Front View

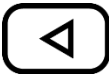

Description of Parts:

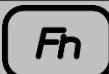
No	Item	Description
1	LED Indicator	LED indicator indicates the battery power or charging status
2	Light Sensor	Light sensor detect the availability of light and automatically control the brightness of a screen backlight intensity
3	Proximity Sensor	Proximity function is used specifically towards near field proximity applications. In mobile phones, the proximity detection can detect when the user positions of mobile phone is close to their ear
4	5" IPS Display	Displays all information needed to operate the device.
5	2MP Front Camera	To capture a front view picture and use for Video call.
6	Function Key	Use to trigger the barcode reader for E500RM8 with barcode reader (differs by product type)
7	All Around Elastomeric Rubber	Protects the device from water and dust
8	Volume Up / Down	Increases or decreases the call volume when a call is in progress. In other applications, it controls the volume of music or
9	Optical Bonded Touch Screen	Optical bonding provides better sunlight reading ability
10	Four Physical Buttons	 Back
		 Opens a home screen
		 Opens a menu with items that affect the current screen or application
		 *Use to trigger the Barcode Reader for E500RM8 with Barcode Reader (differs by product type)
11	Smart Card Reader	To obtain card information and perform a transaction.

**Note:
Fn key
function
s may
be
progra
mmed
accordi
ng to
your
order.*

Rear View



Parts Description:

No	Item	Description
1	Pogo-pin	Pogo-pin can be used for charging & extension function
2	Removable Battery	Removable battery
3	Micro SD Card Slot	Allows installing micro SD card
4	Hand Strap Slot	To install hand strap
5	8MP Rear Camera	To capture a rear view picture and use for making videos.
6	Fingerprint Reader (optional)	Allows scanning fingerprints
7	Barcode Reader (optional)	1D/2D Barcode Reader (<i>*Will change to flat cover when without barcode</i>)
8	Power Button	<p>Press and hold the button for 3 seconds to turn on E500RM8. Press to turn on/off the screen. Press and hold the button for 3 seconds to select:</p> <ul style="list-style-type: none"> • POWER OFF –to turn off the device press button for 8 Sec to force system power off • AIRPLANE MODE –to disable all wireless connection • SILENT MODE – to disable all the sounds except for the alarms • VIBRATION MODE – to vibrate all the notifications across the entire device • NORMAL MODE – Return to the user setting mode Press and hold the button for 8 seconds to reboot the device.
9	Function Key	Use to trigger the barcode reader for E500RM8 with barcode reader (differs by product type)
10	Micro USB	Use for communication with peripheral devices.
11	DC Jack	Use for charging

Dimensions

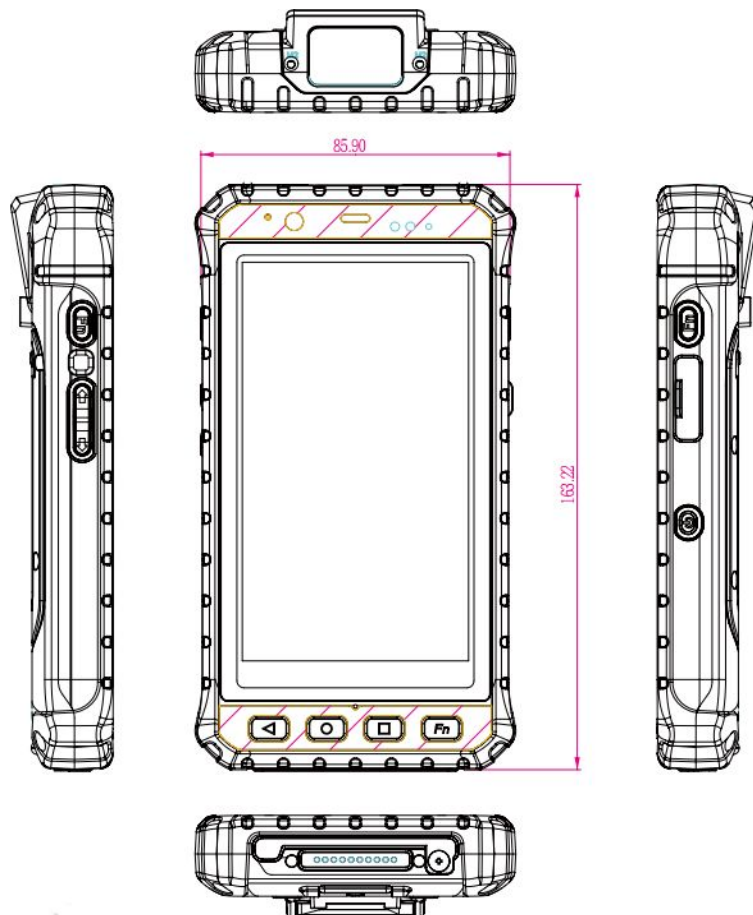

**Note: Measurements shown in mm.*

***Note: this is a simplified drawing and some components are not marked in detail.*

Getting Started

To start using the E500RM8 for the first time:

- Install Micro SD Card
- Install the Battery
- Charge the E500RM8
- Power on the E500RM8
- Configure the E500RM8

SD Card Installation

To Install the SD Card:

1. Place the E500RM8 facing down.
2. Press the two latches up and removable the battery.

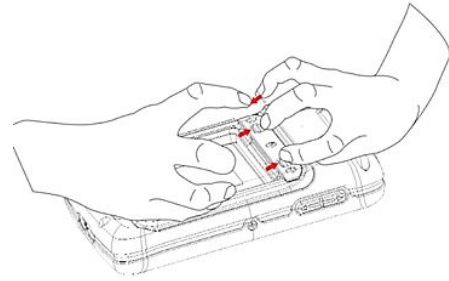
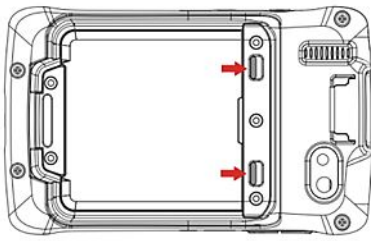

3. Locate the SD card holder.
4. Push the SD card holder in the direction of the arrow to unlock it.
5. Pick and raise the SD card holder up in upright position and then put the SD Card into the socket.

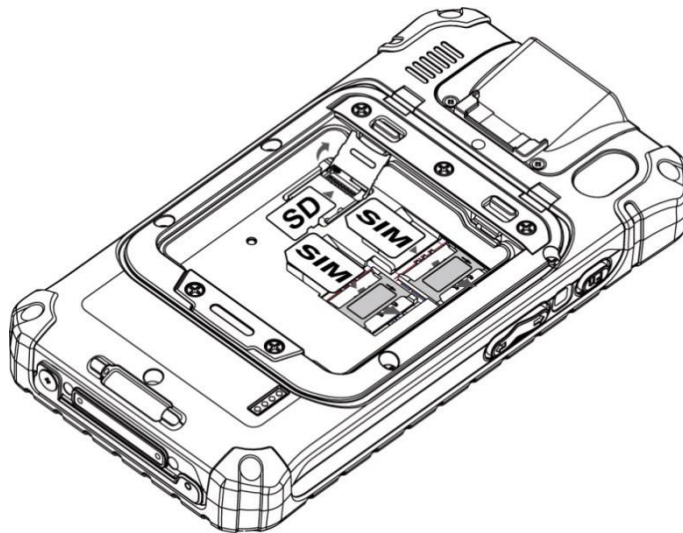

Battery Installation

Inserting the standard Battery Pack into the device:

1. Disconnect AC adapter and power cord from the device.
2. Turn the device over, back facing up.
3. Locate the Battery Lock Latch and push it to the “Unlocked” position.
4. Locate the Battery Release Slider that is spring-loaded. Pull back and hold.
5. Insert the battery on the connector-pins side first, and then lower the battery into the battery compartment. Continue to hold the Battery Release Slider before battery is fully inserted.
6. Make sure the battery is completely lowered into the compartment before letting go the Battery Release Slider. Battery will be flat against the housing once fully inserted.

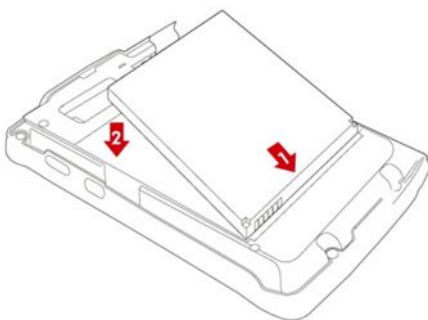

Reinsert the battery by latching the bottom first (1) and then pushing the battery pack down (2).



CAUTION

Check the battery latch:

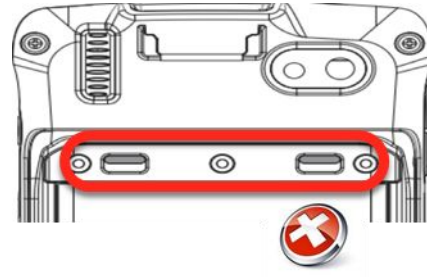
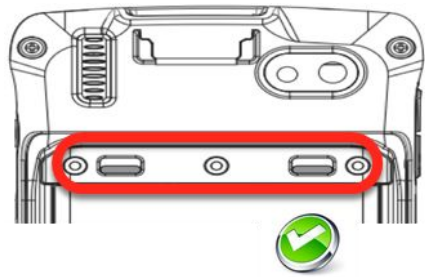

Removing the Battery Pack:

1. Power off the PDA. Disconnect any cords connected to the device.
2. Turn the PDA over, back facing up.
3. Locate the Battery Lock Latch and push it to the “Unlocked” position.
4. Locate the Battery Release Slider that is spring-loaded. Pull back and hold.
5. Lift the battery out using the opening on side of battery compartment.

Charging the Battery

Please charge the battery before using the PDA for the first time, charge the battery until the LED indicator turns solid green. To charge the E500RM8, use a cable or a docking with appropriate power supply. For more information about the E500RM8 accessories, refer to [Chapter 7](#).

LED Status	Indicator
OFF	E500RM8 is not charging or not properly connected
Solid Red	● Charging in progress
Continuously Flash Red	● Indicates low battery status (below 15%*) *Connect to the power source or the system may shut down
Twice Flash Red	● Not enough power for the device to turn on **Charge the device until the LED indicator becomes solid red (Indicates the battery is charged more than 3%)
Solid Green	● Charging complete

Charging the battery using DC Jack cable

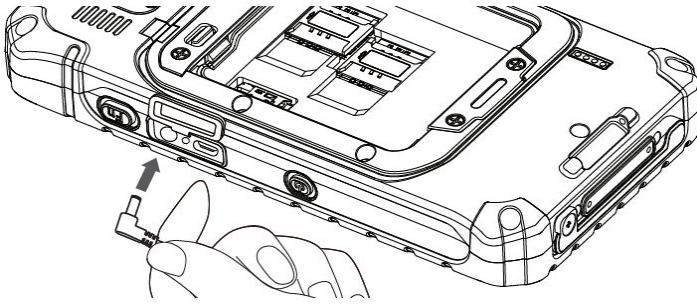

1. Connect the power supply output connector to the input power port on the DC Jack cable.
2. Remove the protective rubber and connect the DC Jack cable to the side of E500RM8. The battery charge LED indicates the battery charging status.

Charging the battery using Battery Charger

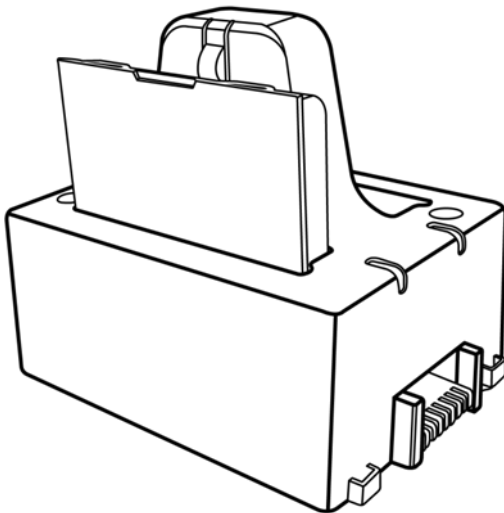

Connect the battery charger dock to power, insert the battery into the slot to begin charging.

This docking provides input: 12V/36W DC in.

Turning On and Off the Device

This section describes how to turn on/ off the device.

Turning ON

Chapter 1 Getting Started

1. Press and hold the power button for 3 seconds, located on the right side of the unit.
2. When the device vibrates, release the power button. The desktop screen is displayed.

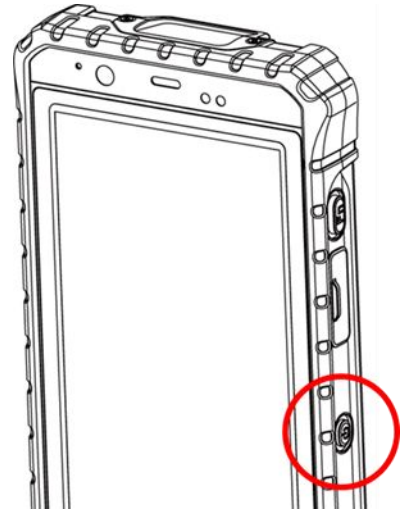

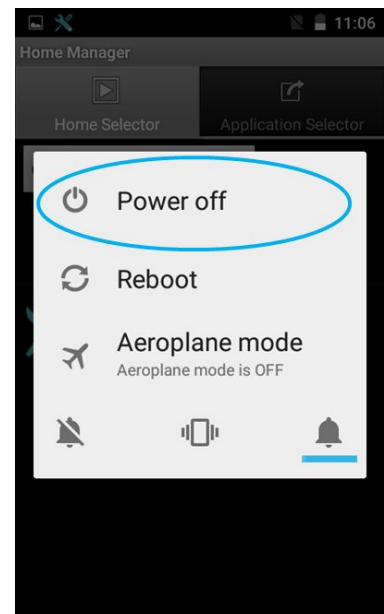

Turning OFF

1. To turn off the device, press and hold the power button until the phone options menu appears, tap the **Power Off**.
2. User can also use the Phone options menu to put the device into silent or airplane mode, see features table.



Resetting to Factory Defaults

To reset the device to factory defaults:

1. Tap **Menu** , than tap **Settings** .
2. In the **Personal** tab, tap **Backup & Reset**.
3. User can select to back up application data, Wi-Fi passwords and other settings to Google servers by tapping **Backup My Data**.
4. Tap **Factory Data Reset** to reset the phone.

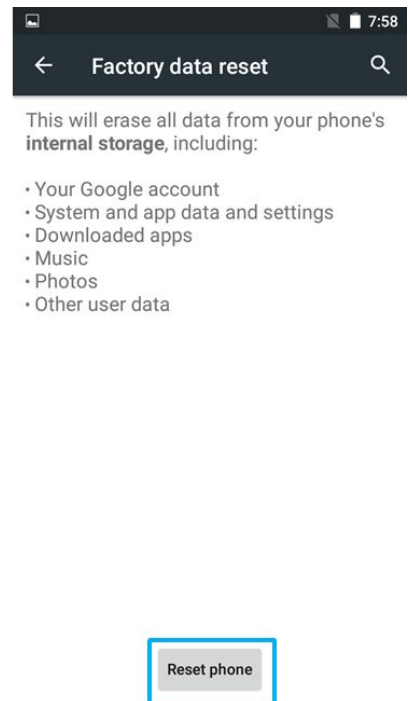
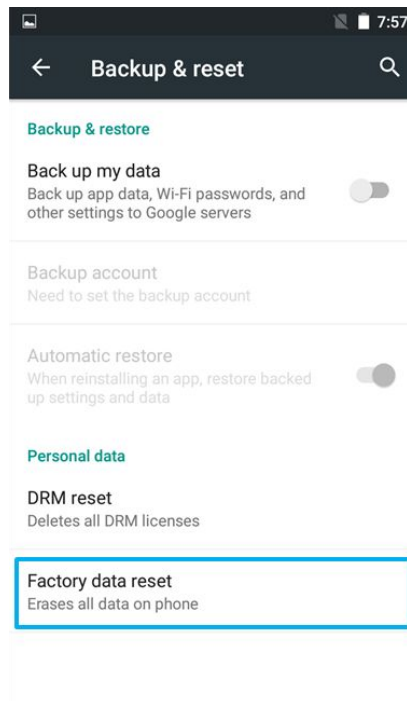
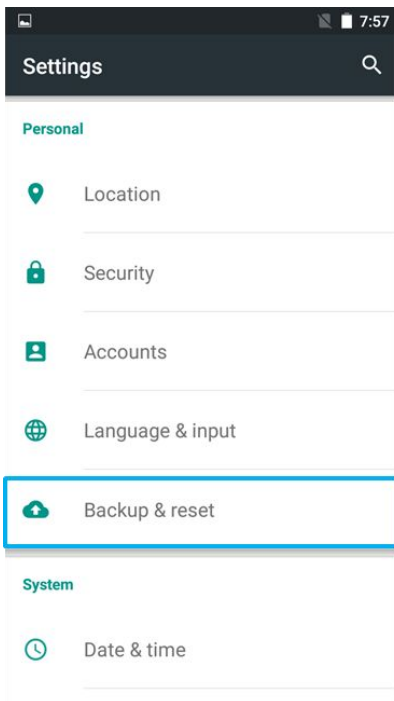







5. Read all the available information and then check Erase phone storage if user wants to erase all the data on the phone storage such as music or photo.

Chapter 2 Using the E500RM8

This chapter explains how to use the buttons, status cons, and controls on E500RM8 PDA running on Android 5.1 Operating System, provides instructions on entering and capturing data.

Using the Touch Screen

The touchpad supports the core gestures for Android.

Gesture	Action	Description
Tap		To select or activate something
Tap & Hold		Touch and hold an item on the screen by touching it and not lifting your finger until it respond
Touch, Hold & Drag		Touch and hold an item for a moment and then without lifting your finger, move your finger on the screen until you reach the target position. i.e. moving the apps around the home screen
Swipe or slide		Quickly move the finger across the surface of the screen. i.e. slide a lock screen to open the lock
Double-tap		Tap quickly twice on a webpage, screen, or App to zoom
Scale		Place two finger on the screen and pinching them together
Rotate		Two-finger press, simultaneously orbit both fingers around the center point, lift.

Waking Up the Phone

If you do not use the phone for a while, the screen dims and then darkens to conserve the Battery. To wake up the phone:

1. Press the Power button on the right side of the PDA.

2. Drag the lock icon  up.

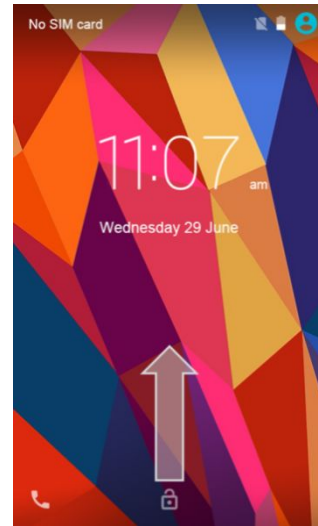
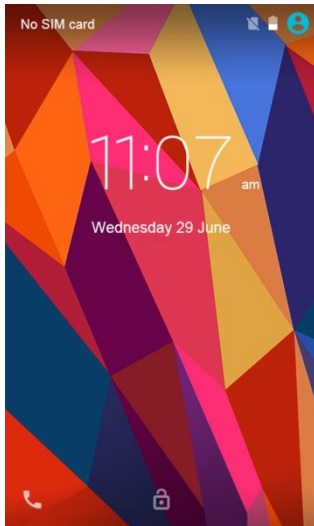

Using the Home Screen

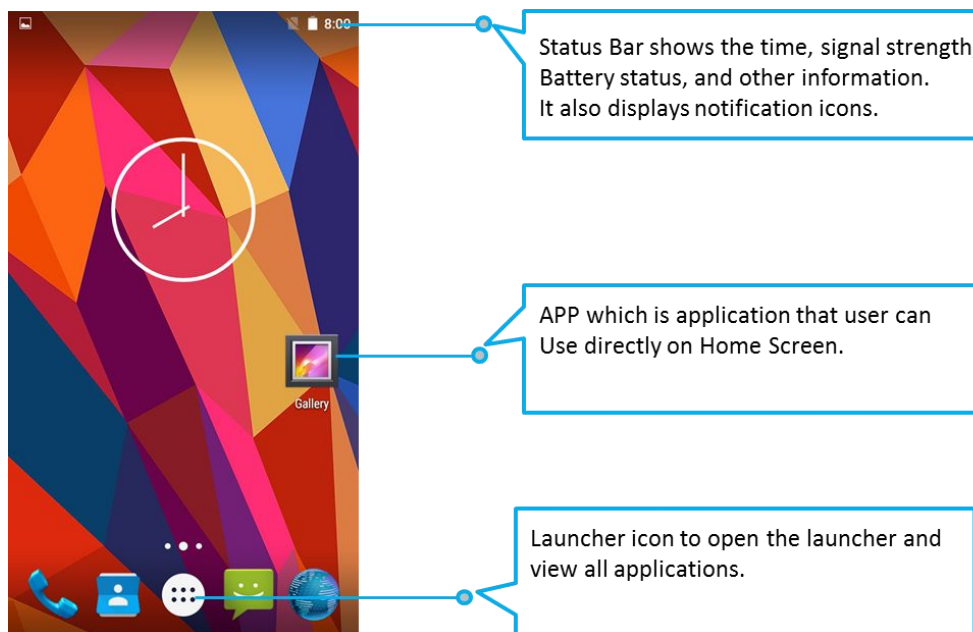

Home screen is the starting point to access all the features on your PDA Device. It displays application icons, widgets, shortcuts, and other features. User can personalize the home screen. See “Personalizing home screen”.



Personalizing Home Screen

User can add application icons, shortcuts, widgets, and other items to any part of any Home screen where there is free space. User can also switch the wallpaper.

To change wallpaper on the HOME SCREEN:

1. Tap **MENU** , and then open **Settings** .
2. In the Device tab, tap **Display > Wallpaper**.
3. In the Wallpaper menu select the location of wallpaper, and then tap the type of item you want to add.

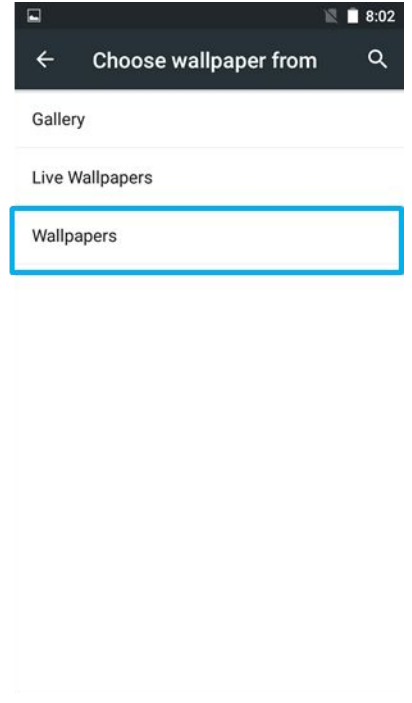
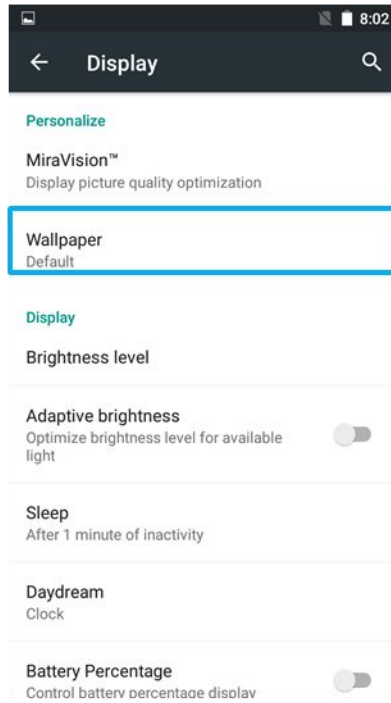
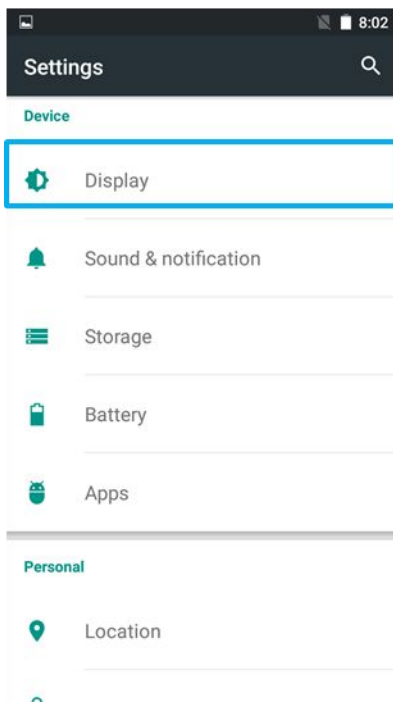

To move an item on the HOME SCREEN:

1. Tap and hold the item you want to move, until it can be moved.
2. Drag it to a new location on the screen.
3. Place the item where you want to put it and lift your finger.

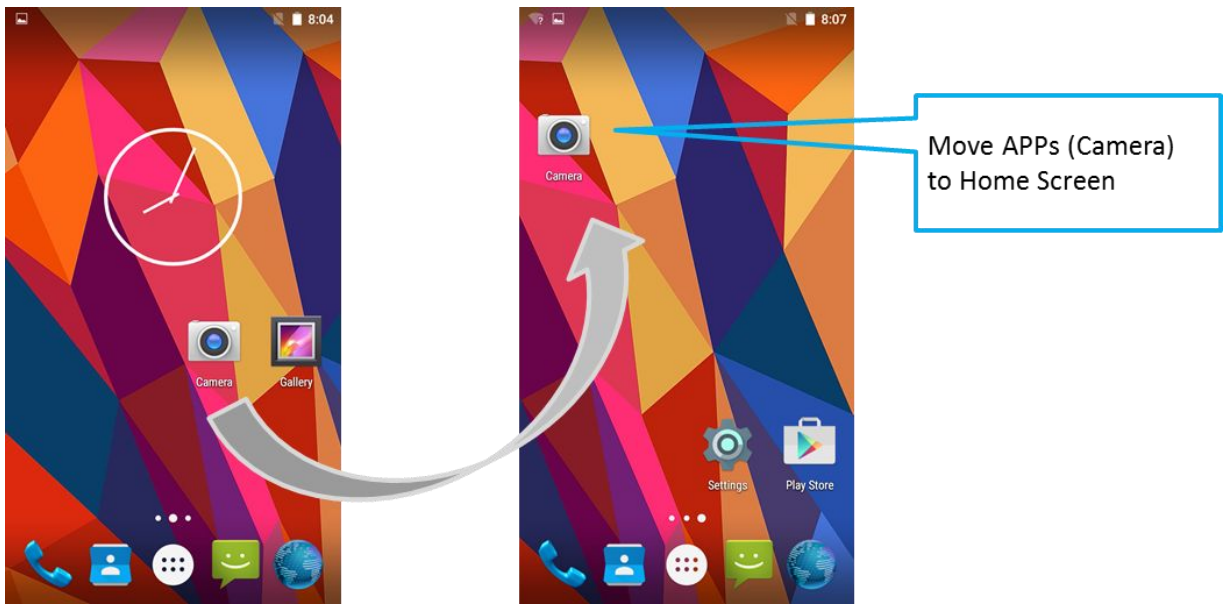

To remove items from the HOME SCREEN:

1. Tap and hold the item you want to remove. The launcher icon will show **Remove** on the top of the screen.
2. Drag the item you want to remove to the Remove icon.
3. When the icon turns red, release your finger.



Viewing other parts of the Home Screen

1. Slide your finger left or right across the Home screen. Extensions to the Home screen provide extra space for APPS, shortcuts, and other items.

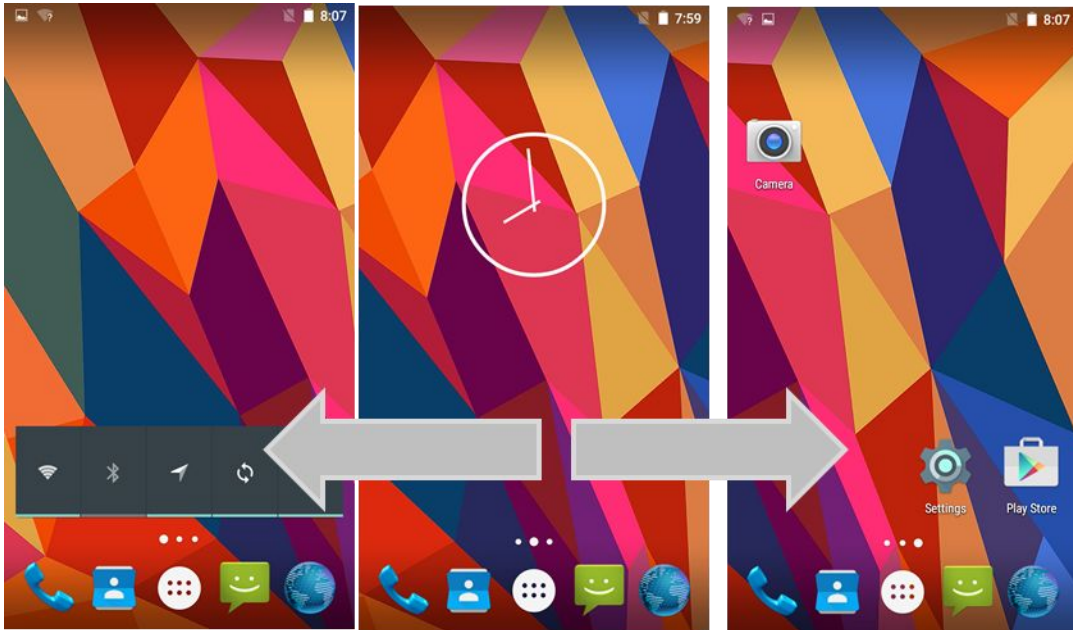

2. Tap the launcher icon  to view the entire APPS of the device.

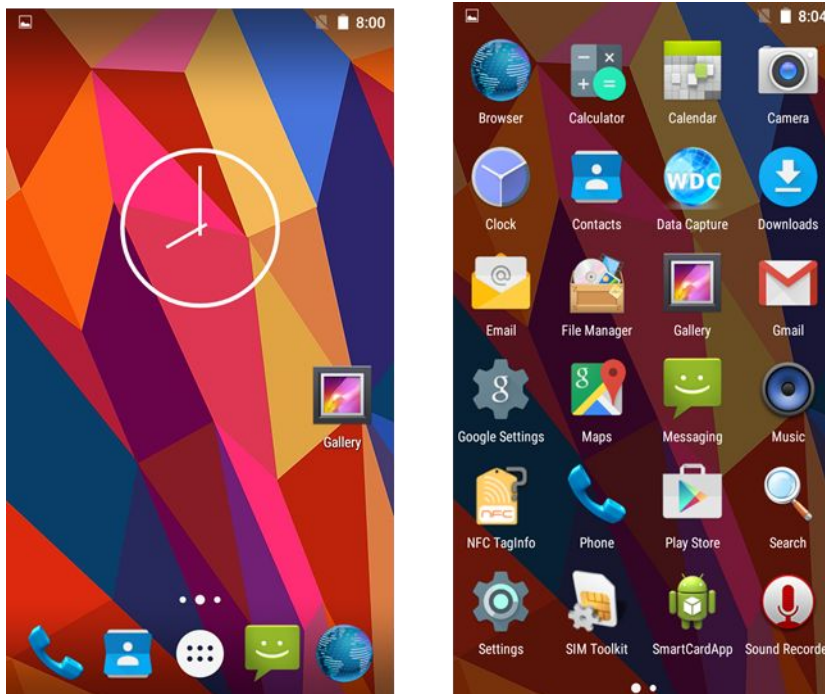

The status bar appears at the top of every screen. On the left are notification icons and on the right are status icons, along with the current time.



Status and Notification Icons

Notification Icons























Pull down from the left top of the screen to get the notifications area. The following icons indicate that you have received notification.

	New email message		Incoming call
	New text or multimedia message		Missed call
	Alarm is set		Speakerphone is activated
	Upcoming event		Phone microphone is muted
	Data is syncing		Downloading data
	Problem with sign-in or sync		Phone is connected via USB cable
	A screenshot is captured		

Status Icons

Pull down from the right top of the screen to get the notifications area. The following icons indicate the status of your device, for example if users are connected to a Wi-Fi network that is not connected to the internet, the network icons are appears in white color.

Status icons that appear in the status bar are as follows:

	Connected to GPRS mobile network		Bluetooth is on
	Connected to 1xRTT mobile network		Connected to a Bluetooth device
	Connected to EDGE mobile network		No SIM card installed
	Connected to 3G mobile network		Vibrate mode
	Connected to 4G mobile network		Ringer is silenced
	Mobile network signal strength		Battery is very low
	Searching for a network signal		Battery is low
	No signal		Battery is partially drained
	Connected to a Wi-Fi network		Battery is full
	Roaming		Battery is charging
	Airplane mode		Receiving location data from GPS



Using the On-Screen Keyboard

User will be able to enter text using the On-Screen Keyboard. Some applications will launch the keyboard automatically. In others, user needs to touch a text field where user wants to enter text to launch the keyboard.

Entering Text

1. Open a text field. The On-Screen Keyboard opens.

*If user taps in a text field which already contains text, the insertion point is set where user tap and the cursor appears. User can drag the cursor to pick exactly where you want to add more text. User can also select a word to copy, cut and paste it. See "[Editing Text](#)".

2. Tap the delete key  to erase characters to the left of the cursor.
3. Tap  to enter numbers. Tap  to return to letters.
4. To enter symbols and other characters, tap and hold one of the top-row keys and slide your finger up to the list of the options. Lift your finger when you find your selection.



- To view additional symbols, tap  on the numeric keyboard.

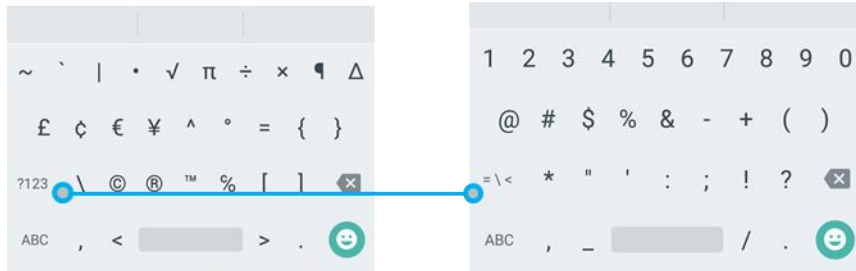

- To close the On-Screen keyboard, press the back button .



Editing Text

To select text:

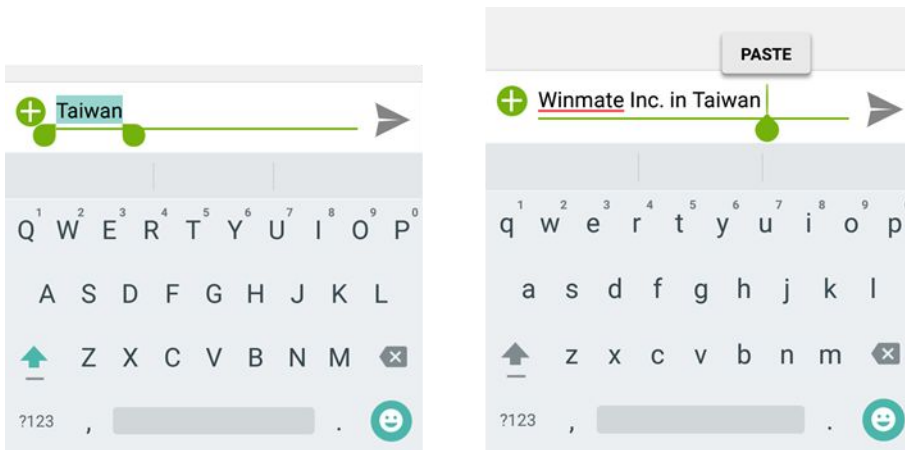
- Double-tap the text you want to select.
- Tap  to select all the sentences in the menu that appears, the selected text is highlighted in blue, with a tab at each end of the selected word.
- Drag selection tab to expand or reduce the range of the selected text.



To Cut or Copy Text:

- Select the text to cut or copy, see the section above "To select text".
- Tap  or  in the Edit text menu.

- If you select , the selected text is removed from the text field; it is stored in temporary area so that you can paste it into different text field.

To Paste Text:

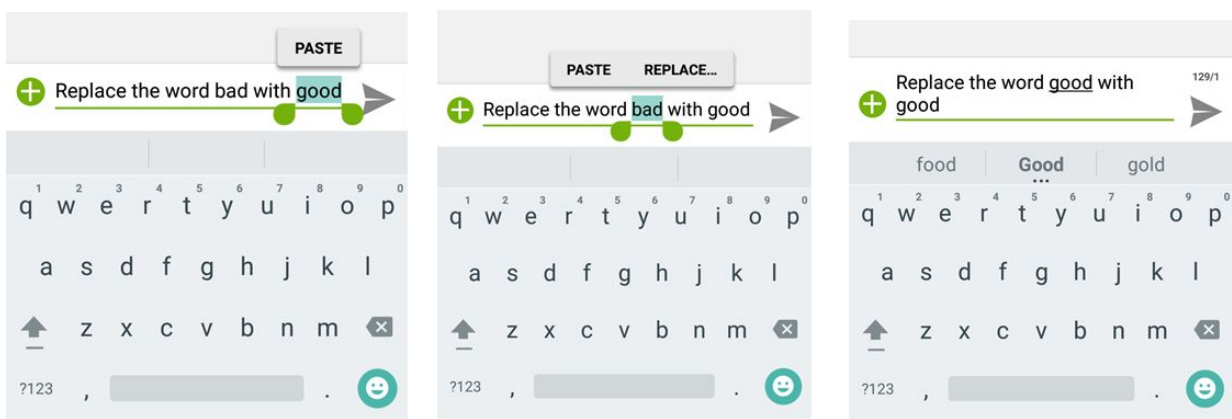

- After Cut or Copy the text, see the section above “To Cut or Copy Text”
- Place the cursor in the text field where you want to paste the text, user can paste text that you copied from one application into a text field in any application.
- Tap and hold into the location that you want to paste. Tap **PASTE** in the menu that opens or user

can also tap  to replace the existing text with copied text.



Display Settings

Use the display settings to configure brightness and other screen settings.

- Tap **MENU**  and then tap **Settings** .
- In the **Device** tab, tap **Display**:
 - **Personalize**
 - **MiraVision™** - to display picture quality optimization options.
 - **Wallpaper**– to select wallpaper
 - **Display**
 - **Brightness level**– for adjusting the brightness of the screen.
 - **Adaptive brightness** – to optimize brightness level for available light
 - **Sleep**– to set up the device on the sleep mode after one minutes of inactivity
 - **Daydream**- to activate automatically when your device is docked or charging, keeping your screen on and displaying information. Daydream mode can give your device an always-on information display.

- **Battery Percentage**– to control battery percentage display.
- **Font size**– for adjusting the font in the device.
- **When device is rotated** – for switching the orientation of the screen as user turn the device sideways or upright.
- **Sleep**– to inactivate the device after some time.
- **Cast screen** – allows displaying whatever is visible on the device's screen on another screen, mostly wirelessly using Wi-Fi as a medium for sharing the screen.

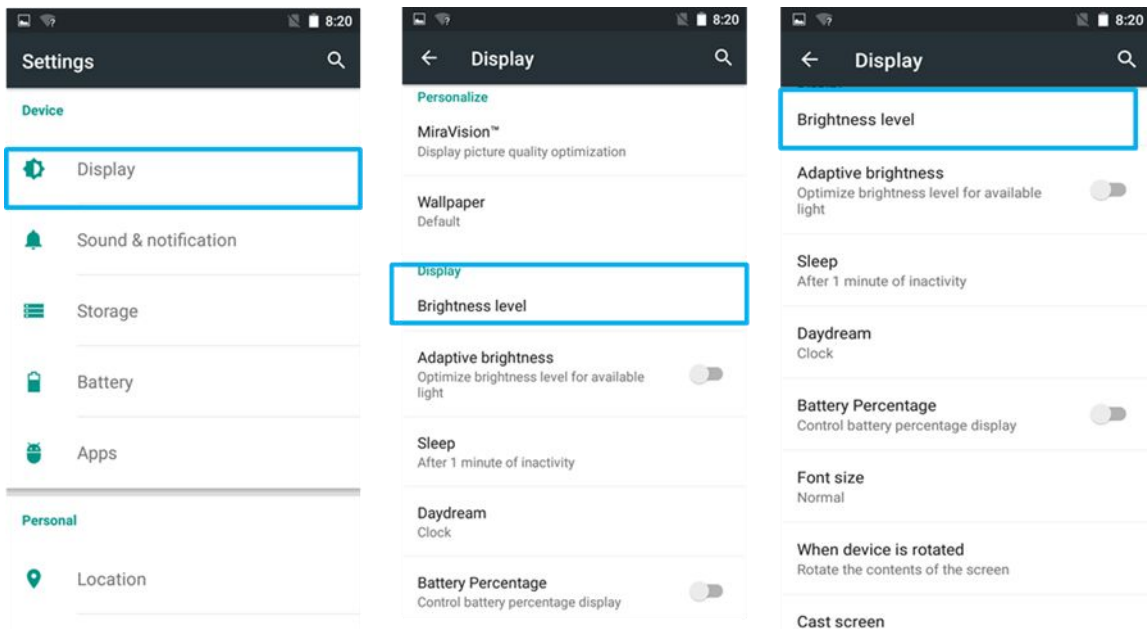



NOT
E

For the longest battery life between charges, use the shortest Sleep time.

Audio Profile Settings

Use the sound settings to configure how and at what volume the phone rings, vibrates or alerts user in other ways when user receive a call, receive a notification or an alarm sounds.

Sounds Settings

1. Tap **MENU**  and then tap **Settings** .
2. In the **Device** tab, tap **Sound & Notification** and then user can select General, Silent, Meeting or Outdoor profile.

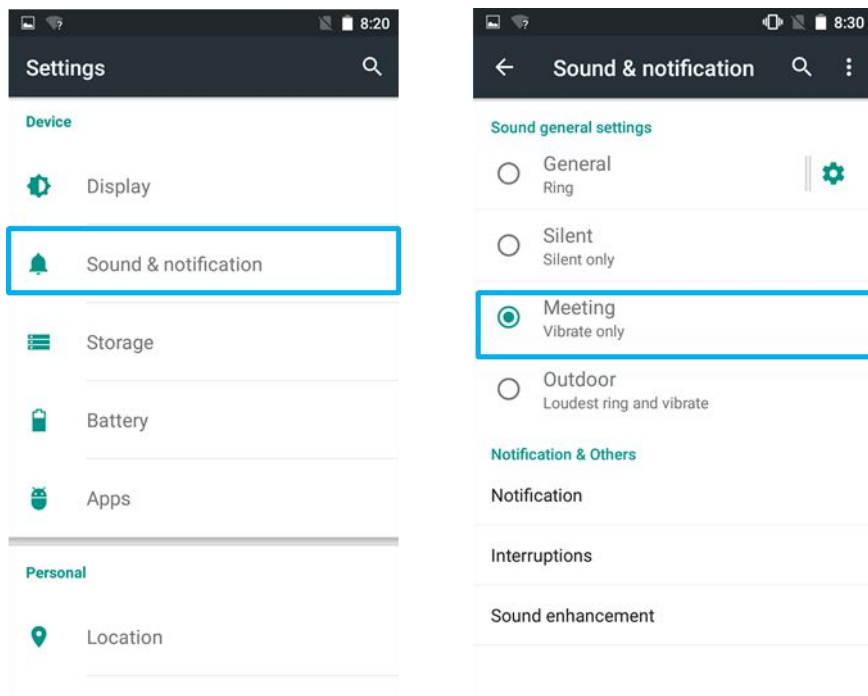

Adjusting Volume

1. Press the volume keys to change the ring volume (On Home screen) or earpiece volume (during a call).





2. Press the volume key to set up Vibration mode.



Language and Keyboard Settings

Use the Language & keyboard settings to select the language for the text on your phone and for configuring On-Screen Keyboard, including words that you have added to its dictionary.

1. Tap **MENU**  and then tap **Settings**  .
2. In the **Personal** tab, select **Language & Input**.
 - **Language** – to open the language screen, where user can select the language to use for the text on the device.
 - **Spell Checker** – to activate Android Spell Checker (AOSP) and check to correct misspelled words.
 - **Personal dictionary**- to open a personal dictionary.
 - **Keyboard & input methods**
 - **Current Keyboard** – to apply the onscreen keyboard that is included with user’s device.
 - **Android Keyboard (AOSP)** – the setting screen is available only if user’s device has a physical keyboard.
 - **Appearance & layouts**
 - **Theme** – to select the theme of layout
 - **Custom input styles** – user can select custom input style, such as QWERTY keyboard
 - **Text Correction**
 - **Personal dictionaries**
 - **Add-on dictionaries**
 - **Block offensive words** – disable suggesting potentially offensive words
 - **Auto-correction** – spacebar and punctuation automatically correct mistyped words.
 - **Show correction suggestions** – display suggested words while typing.
 - **Personalized suggestions** – learn from your communications and typed data to improve suggestions.
 - **Suggest contact names** – use names from Contacts for suggestions and corrections.
 - **Next-word suggestion** – use previous word in making suggestion.
 - **Advanced**
 - **Key popup dismiss delay**
 - **Keypress vibration duration**

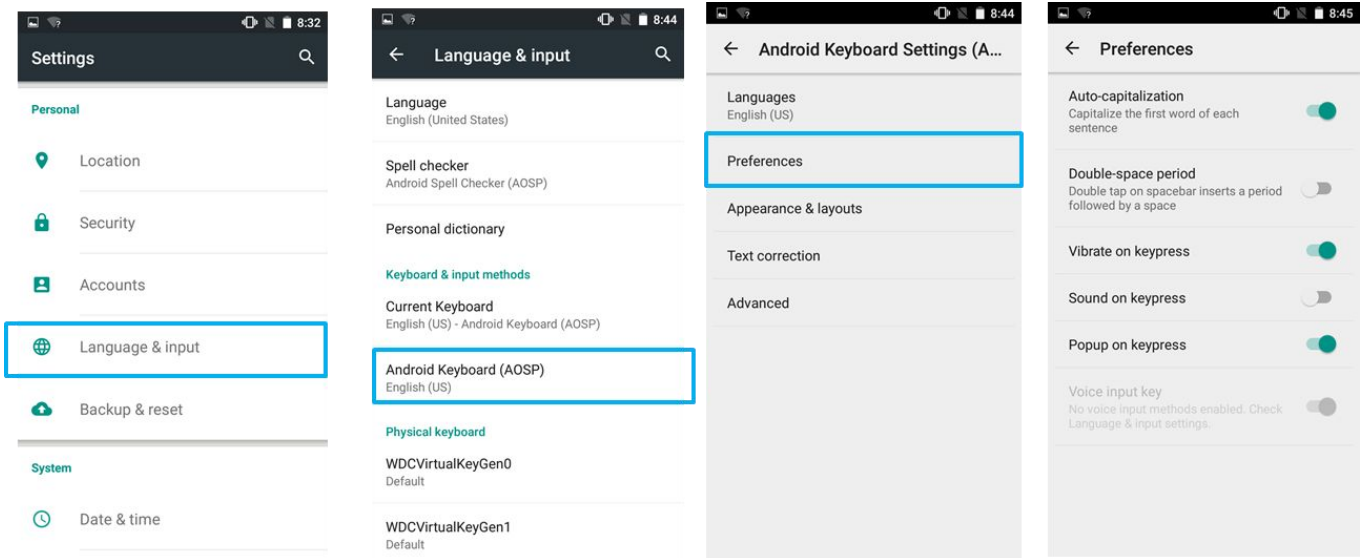

Changing the Keyboard Language

The current keyboard language is displayed on the Space key and user can switch languages.



1. Tap and hold the space key
2. Without lifting the finger, slide it to the left or right until the language you want to use appears in the center of the small window above the Space Key.
3. Lift the finger to change the keyboard language.

About Phone

About Phone includes information about user's phone.

- **System Update** — provides information regarding the local or online update of your devices.
- **Status** — opens the status screen with a list of information about battery, network, signal strength and other details.
- **Legal Information** — lists details about the model number, Android Version, Baseband version etc. this information is useful if user need to work with support team.

To access the information about the phone:

1. Tap **MENU** 
2. Tap **Settings** 
3. Scroll down to **System**, and then tap **About phone**.

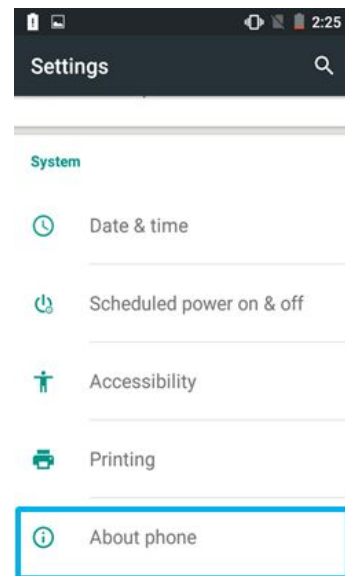

Chapter 3 Using Winmate® Home Manager (WHM)

Every E500RM8 PDA comes with preinstalled APP named Winmate® Home Manager (WHM). This application lets the device manager to lock the launcher. When the launcher is locked the user can only use one application assigned by the device manager.

How to Lock Applications

Step 1

- In the main APPS window, select the Home Manager APP and enable it.
- Select Home Manager to start your settings.
- Go to **Password Manager** and set your own password for this APP. The default password is “0000”.

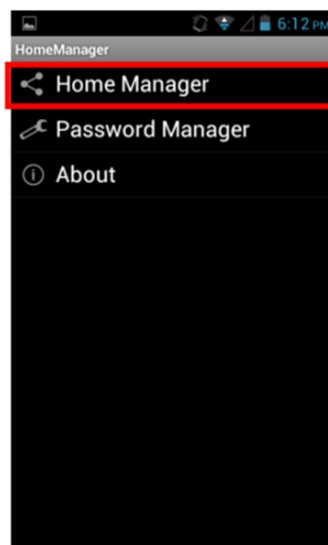
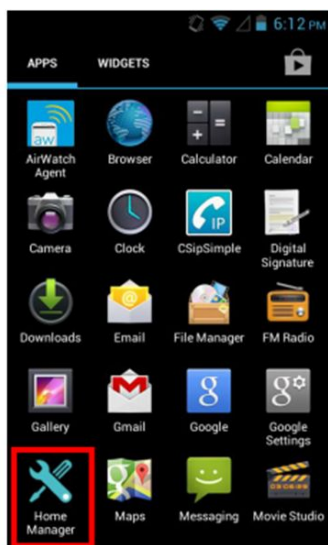

Step 2

- Go to “**Application Selector**” and choose an Application to be locked.

Example: Select the Calendar AP.

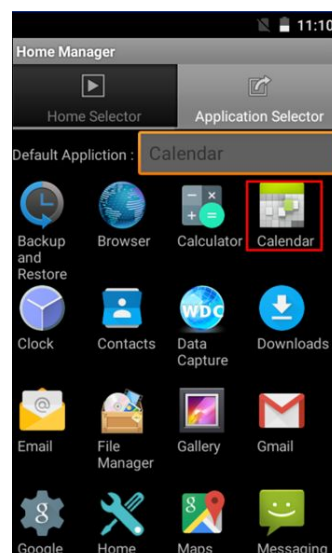

Step 3 Go back to “Home Selector” and press “Clear and Reset Default Home”.

Step 4 Select “Restrict Home”, and then restart the PDA.

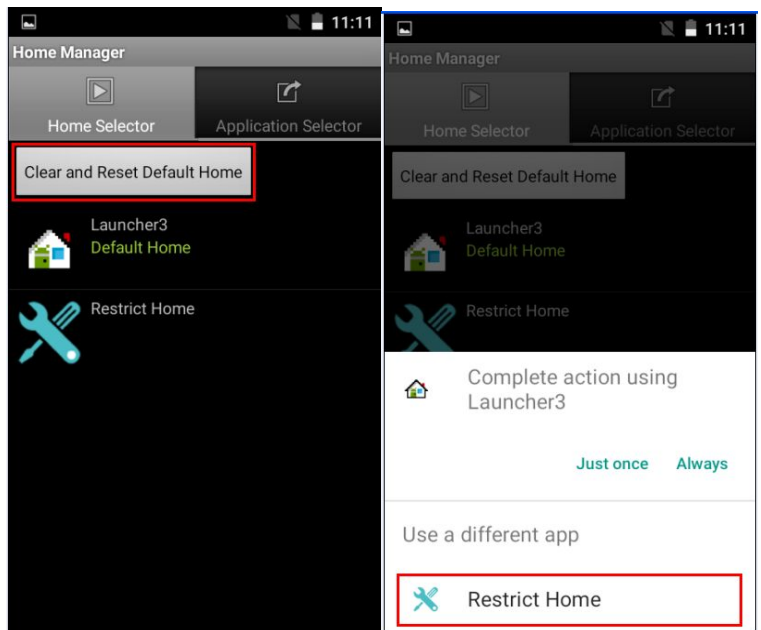

Step 6 System will ask to select “Just once” or “Always” to use this launcher, please select “Always”.

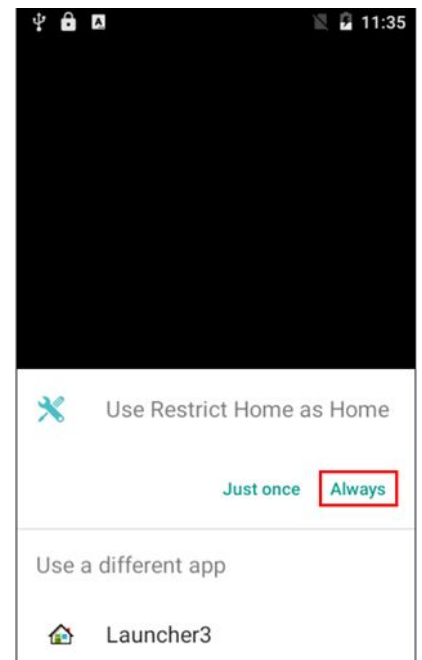

Chapter 3 Using Winmate Home Manager

The system will automatically start the application which you selected and lock it.

Any time you press home key or back key, the system will go back to the same application which you have selected.

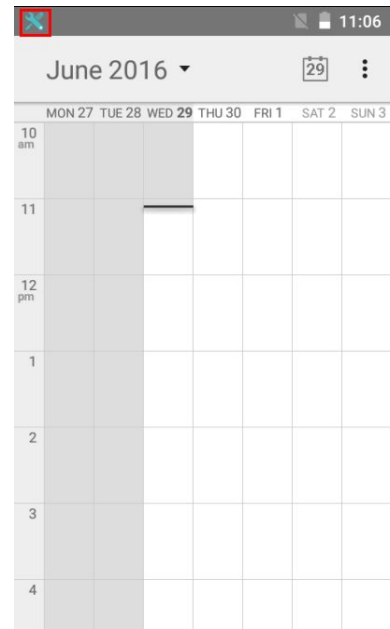

How to Unlock Applications

Step 1 Slide down the top bar and press “Home Manager” icon then you can find the menu and please enter the password to login (The default password is “0000”).

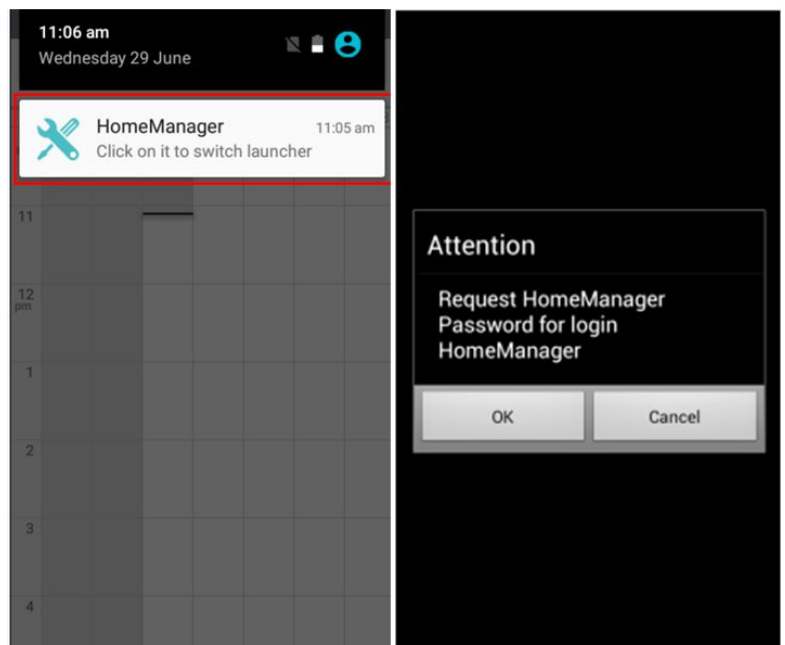

Step 2 Go back to “Home Selector” and press “Clear and Reset Default Home”.

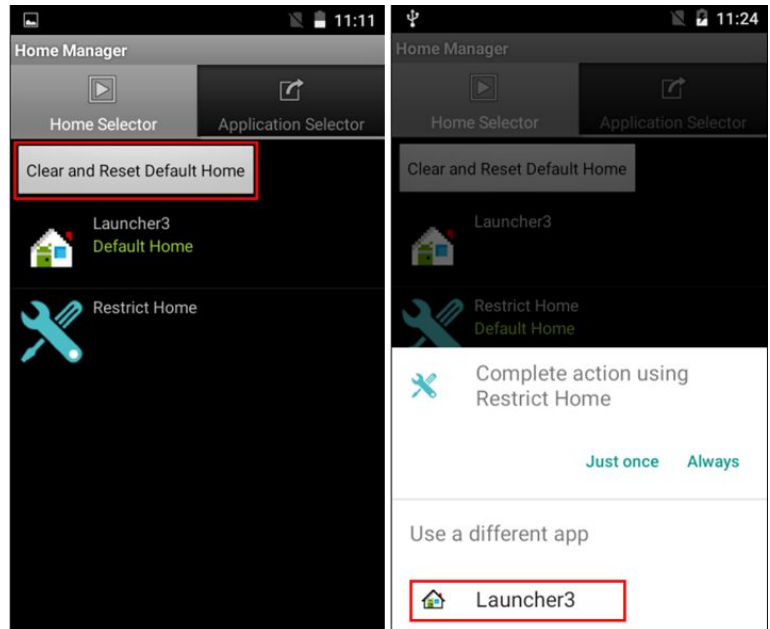

Step 3 Restart the system and you will go back to the normal Launcher.

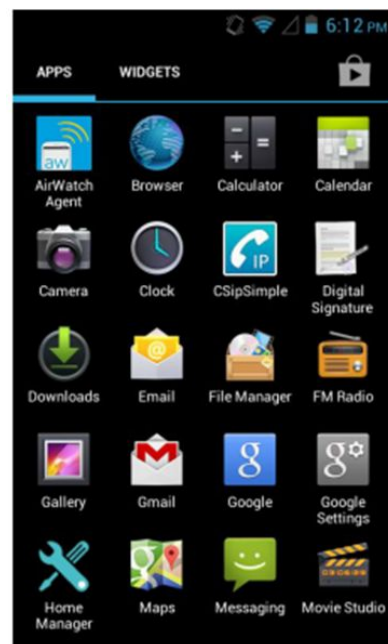

How to Change Password

Step 1 Go to **Password Manager** and set your own password for this APP.

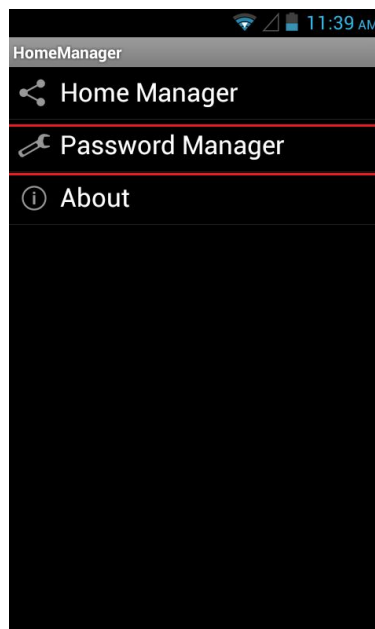

Step 2 The default password is “0000”. Enter a new password in **New Password field**, and then tap **Change Password**.

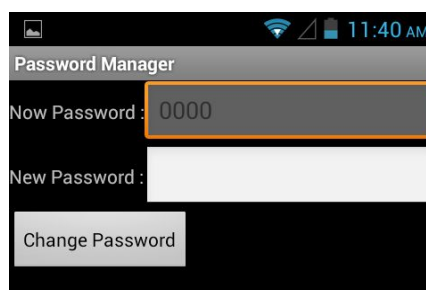



Chapter 4 Connecting to Network and Devices

This chapter explains how to connect PDA to network and peripheral devices.

Connecting to Wi-Fi Networks

Turning ON the Wi-Fi and Connecting to Wi-Fi networks

1. Tap **MENU**  and then tap **Settings**  .
 2. Tap **Wireless & networks** and then select **Wi-Fi** to turn it on  .
 3. Tap **Wi-Fi**. The device scans for available Wi-Fi networks and displays the list of it. Secured networks are indicated with a lock icon. If the phone finds a network that you have connected previously, it connects to it automatically.
 4. Tap a network to connect to it:
 - If the network is open, you are prompted to confirm that you want to connect it by tapping **Connect**.
 - If the network is secured, users are prompted to enter a password or other credentials.
1. To check the details about the speed, security, address and related settings, tap its name in the Wi-Fi settings screen.

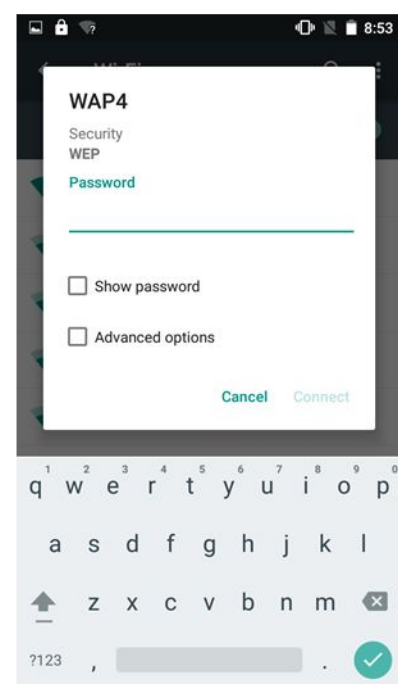
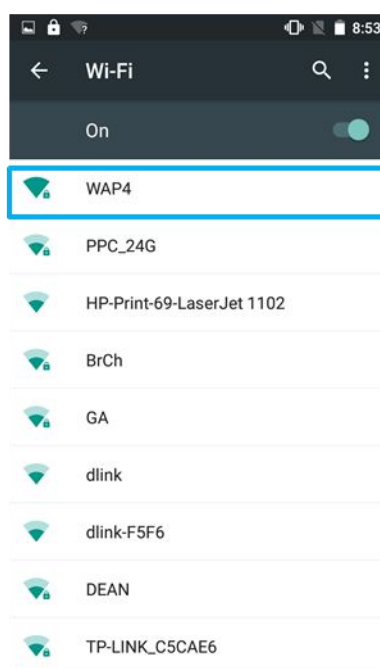
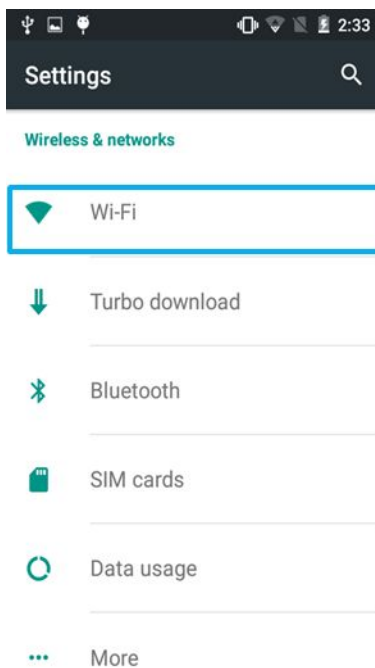

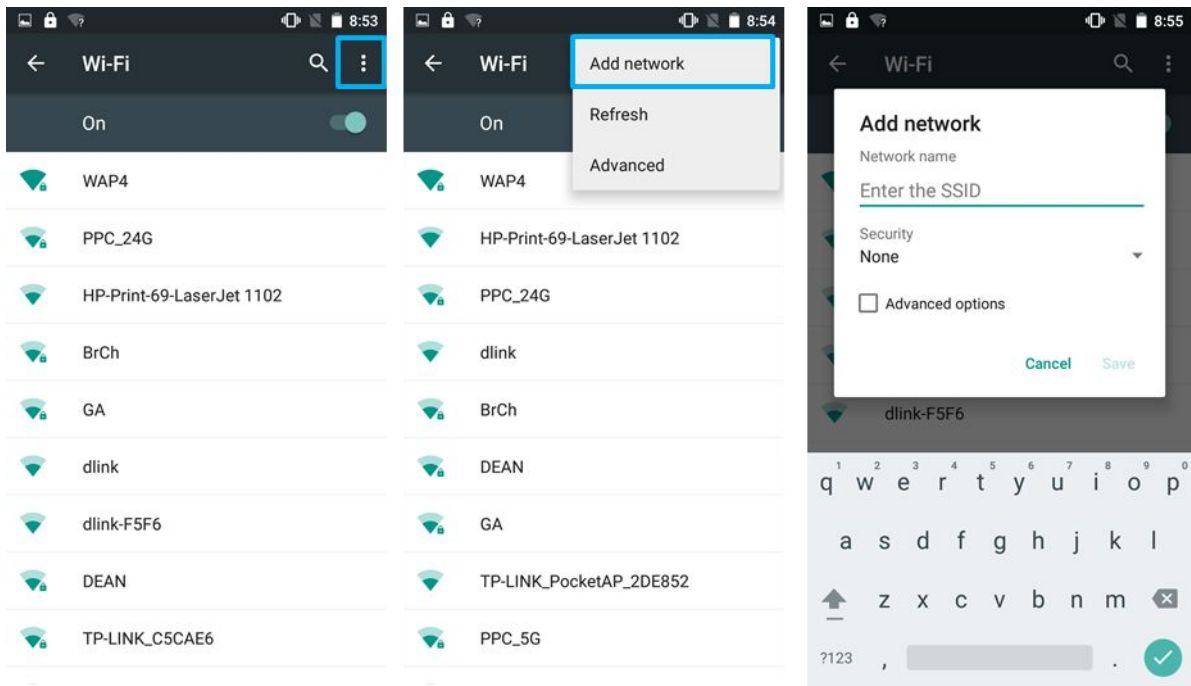

Adding Wi-Fi Network

1. Turn on Wi-Fi, in the Wi-Fi settings screen, tap + icon (at the bottom right of the list of discovered networks).
2. Input the SSID (name) of the network, if the network is secured, tap the security menu and then tap the type of security deployed on the network.
3. Enter any required security credentials.
4. Tap **Save**.



Connecting to Bluetooth Devices

Turning Bluetooth ON or OFF

1. Tap **MENU**  and then tap **System settings** .
2. Tap **Wireless & networks** and then select **Bluetooth** to turn it on.

Connecting to Bluetooth Device

1. Go to **Settings** .
2. Tap **Wireless & networks**, and then tap **Bluetooth** settings.
3. It will automatically scans and displays the IDs of all available Bluetooth devices in range. Tap **SEARCH FOR DEVICES** to search other Bluetooth devices.
4. Tap the **ID** of the other device in the list in Settings to pair them.

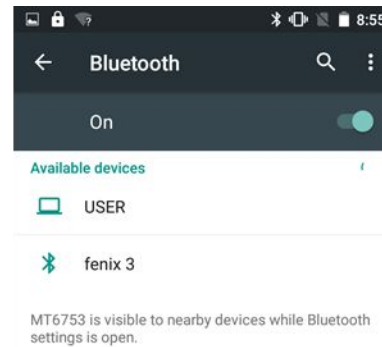
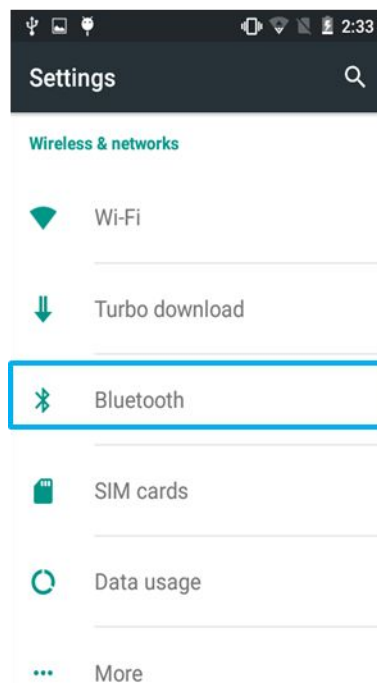

Disconnecting Bluetooth Device

1. Tap the device in the Bluetooth settings screen.
2. Tap **OK** to confirm that you want to disconnect.

Connecting to Computer via USB

User can connect their PDA to a computer with USB cable to transfer files between PDA and computer.



IMPORTANT

- When connecting your PDA to a computer and inserting its USB storage or SD card, user must follow the computer's instructions for connecting and disconnecting USB device, to avoid damaging or corrupting files.
- Notice that the E500RM8 cannot be charged via USB.

USB Computer Connection

1. Enter setting menu , and enter select "Accessibility", and then check "**Connect to PC**".

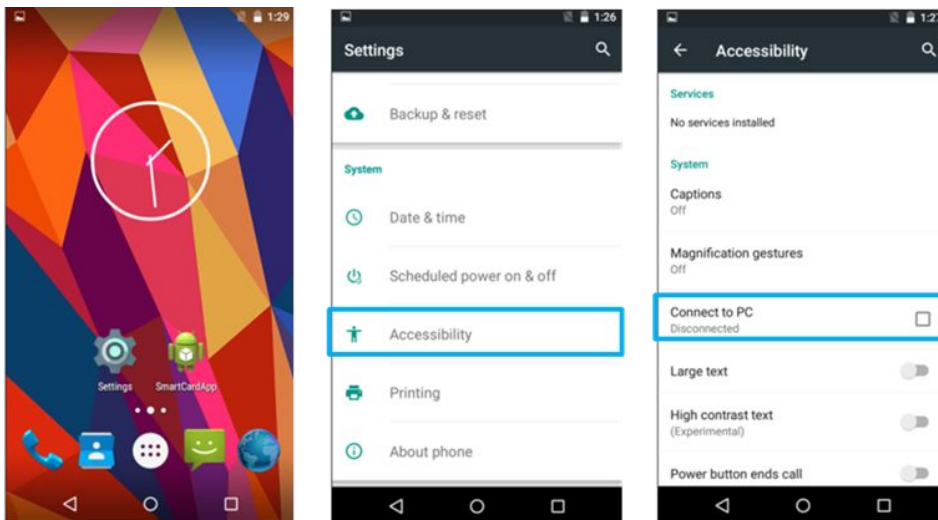

2. Connect PDA to the computer via USB connector.

3. In the notifications area **USB connected sign**  will appear.

4. Pull down the notification area to open notification panel.

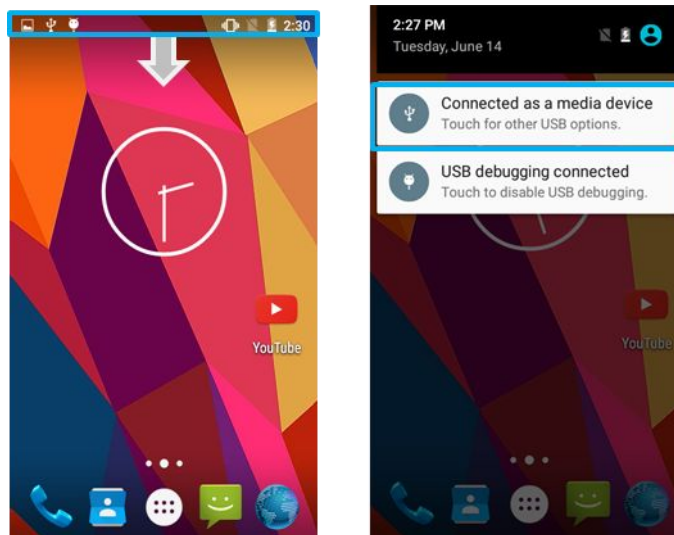

5. Tap this icon  to choose the type of USB connection.
- **USB storage** –let user transfers files between computer and PDA.
 - **Media device (MTP)** – let users transfer media files.
 - **Camera (PTP)** – let users transfer photos using camera software, and transfer any files on computer that don't support MTP.
 - **Charge only** – stop all USB functions and let users speed up USB charging.
 - **Connect as CD-ROM.**

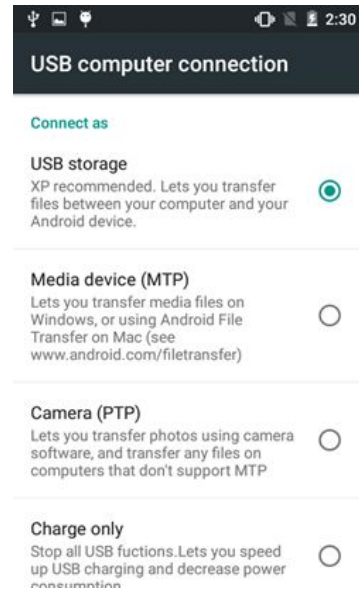

USB Debugging Settings

To permit debugging tools on a computer to communicate with User's PDA via USB Connection.

1. Connect PDA to the computer via USB cable.
2. In the notifications area **USB debugging connect** sign  will appear.
3. Pull down the screen to open notification panel.

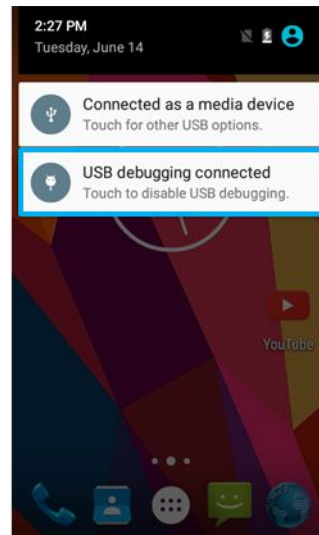
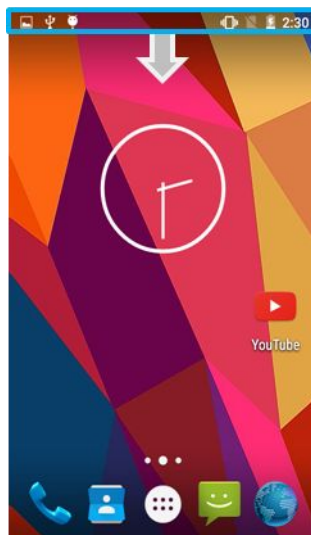

4. Tap **USB debugging connected**.

5. In the **Developer options** user can choose the action to perform.

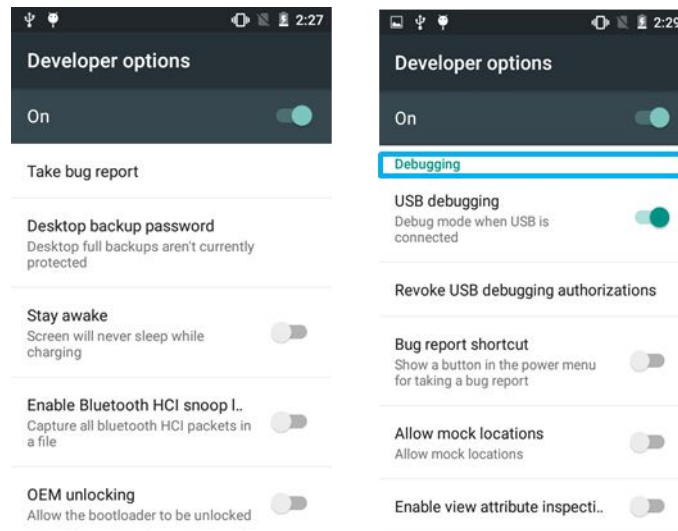

Carefully follow your computer's instructions to un-mount the USB storage or SD card. Disconnect USB device not properly can cause a loss of important data or information.

IMPORTANT

Chapter 5 Using Camera

This chapter explains how to use camera to capture photos and videos.

Capturing Photos or Video

Winmate® E500RM8 equipped with 8 MP on the rear side and 2 MP on the front side, which user can use to capture photos or video.

Opening Camera

1. Tap the launcher and then tap **Camera** .



Camera opens in Portrait mode, ready to take a picture or shoot a video.



Make sure the protective lens cover is clean before taking pictures. A lens cover with smudges from fingers can cause blurry pictures.

IMPORTANT

Taking pictures

1. Adjust the exposure, flash, and other necessary settings. Or leave it automatic.
2. Frame your subject / object on screen. User can set whether user want to use the front or rear camera, by tapping . Scale the screen to zoom in or out.
3. Tap the On Screen Shutter icon .
4. The camera brings the image into focus, when the image is in focus, the focus indicators in each corner will turn green and ready to capture.
5. Tap  to change camera settings.

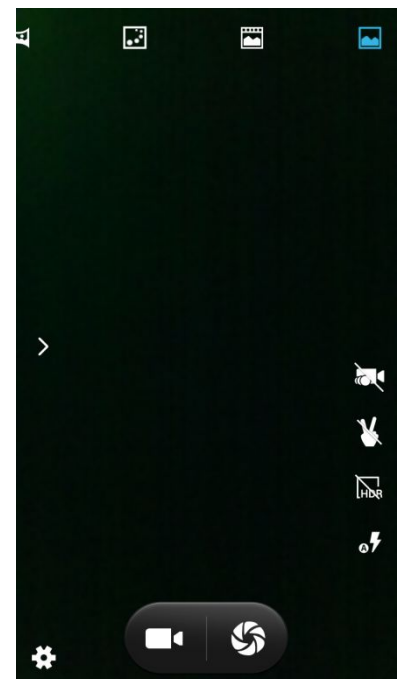

Switching between front and rear cameras

E500RM8 has both a front and rear camera, user can select which camera you want to preview and take pictures with.

1. Tap the On Screen Select Camera icon to switch between the rear camera and the front camera .
2. The preview switches to show the scene viewed from the camera you selected.





NOT

Not all features (such as flash) are available for the front camera.

E

Viewing pictures

1. After taking a photo, a thumbnail of the picture is shown on the corner of the capture screen. Tap the thumbnail to view it.
2. Tap the onscreen button:
 -  to share a photo.
 -  to delete a photo.
 -  to view other photos and videos in the gallery.
3. Swipe right or left to view more photos.

Shooting videos

1. Tap the  to start recording video.
3. The countdown time remaining to shoot is located on the upper left; when the time left is less than a minute, the countdown turns red.
4. Point the lens to record the scene where you want to start.

Tap the  icon again to stop shooting.

The time remaining to shoot counts down at the left; when less than a minute is left, the countdown turns red.

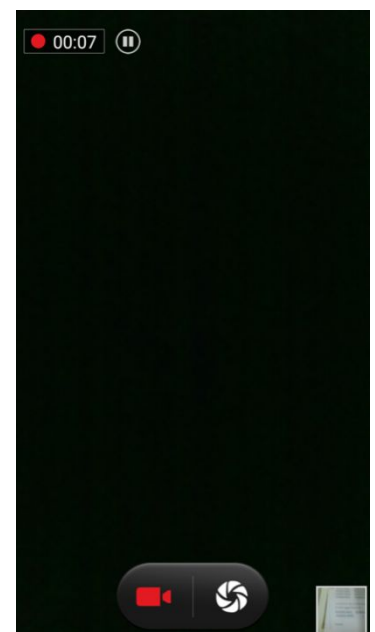

Opening the Gallery

1. Tap the launcher and then tap Gallery .
2. Tap a folder to view the pictures or video inside in full screen mode.
3. Flick the pictures left or right to view the previous or next picture.

Chapter 6 Capturing Data

This chapter explains how to use Barcode Reader and Android Winmate® Data Collection application, Smartcard Reader and Fingerprint Scanner on the E500RM8.

Using Barcode Reader

Location

1D/2D Barcode Reader is an optional feature for Winmate® E500RM8 and may not be present in your device. Barcode Reader is located on the top side of the PDA.

With Barcode Reader

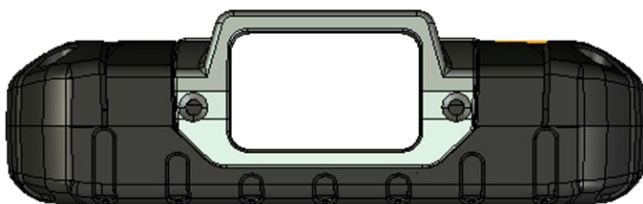



Without Barcode Reader



Android Winmate® Data Collection (WDC)

The E500RM8 with Barcode Reader comes with pre-installed software made by Winmate® - Winmate Data Collection (WDC) that allows users to turn on the readers and set up the button to trigger the scan function.

Where To Find WDC?

1. Tap application menu .
2. User can find the application **Data Capture (WDC)** on the menu screen, with the Globe mark .
3. User can change the settings of the Barcode Reader through WDC application.



How to Turn On/Off the Power of Barcode Reader

1. Go to the WDC application.
2. Tap **Barcode Setting** .

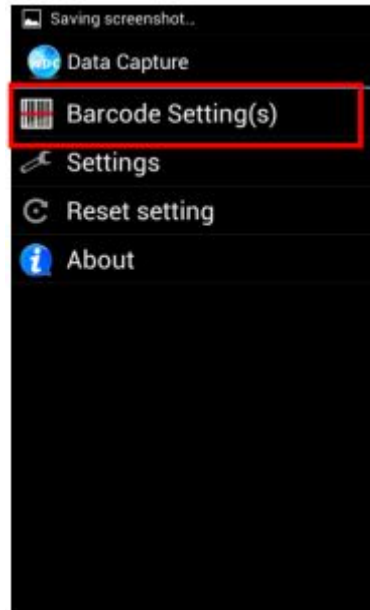

3. Once the user entered the WDC application, the device will automatically turn on the Barcode Reader. And the user can turn off the Barcode Reader by tapping **Barcode Power Status: ON**.

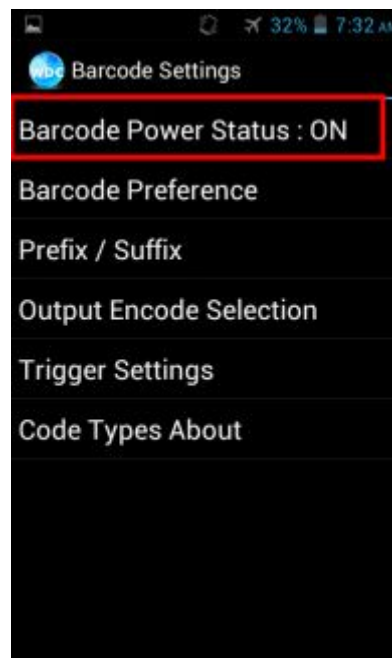

How to change the symbologies of Barcode

1. Go to the **WDC application**.
2. Tap **Barcode Settings** .
3. Tap **Barcode Preference**.
4. Users can change the symbologies of the barcode:

- 1D Symbologies
- 2D Symbologies
- Imager Options
- User Preference
- Disable all symbologies.

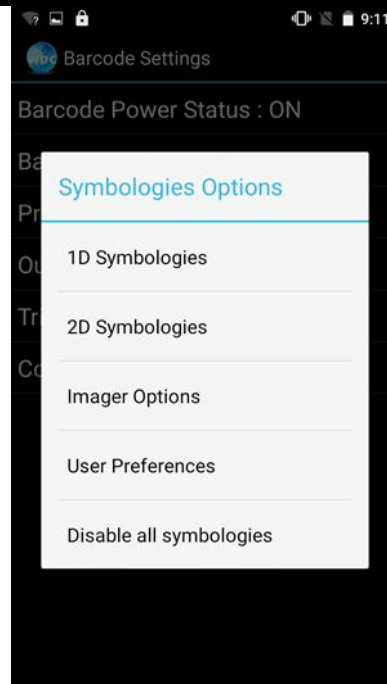

How to add command to my output of the barcode

1. Go to the **WDC application**.
2. Tap **Prefix / Suffix**.
3. Enter special characters at the beginning (prefix) or end (suffix) of the scanned barcodes.
4. Tap **Set** to add into the data.

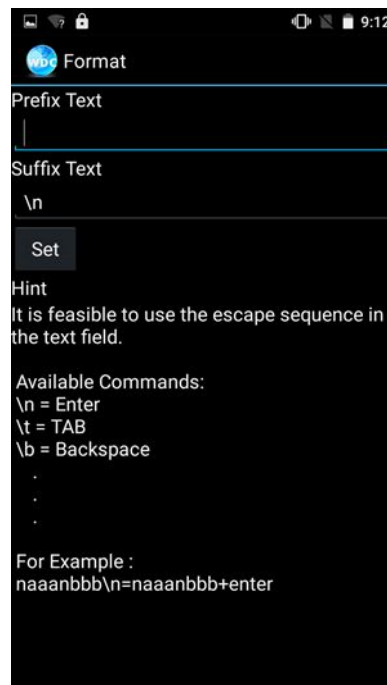

The output will show the command that you entered in the prefix or the suffix;

For example, if user enters “\n” in the **prefix text**, the output of the barcode reader will appear on the next line of the page. And if the user enters “\n” in the **suffix**, the **output of the barcode reader** will show the barcode and change to the start of the next line for the user. Same with the command “\t” and “\b”.

How to change the scan type for the Barcode Reader

1. Go to the “WDC” application.
2. Go to **Barcode Settings** , tap **Trigger Settings**.
3. Select the **Scan Type** or select read time of the Barcode Reader.

To start scanning the barcode user has to leave the WDC application.

- **Auto Scan** – Barcode Reader starts auto-scanning once the user leaves the WDC application.
- **Multiple Scan** – After pressing the trigger button Barcode Reader starts continuously scanning and reading **multiple codes** within the time duration specified in **Read time option**.
- **Continuing Scan (default)** – After pressing the trigger button Barcode Reader can scan and read only a **single code** within the time duration specified in **Read time option**.

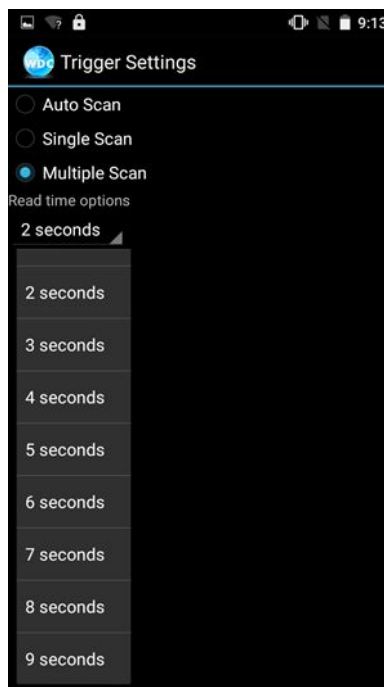

How to change the setting of the application WDC or reset the setting back to default

1. Go to the **WDC application**.
2. Tap **Settings**.
3. Users can select the options to change the setting of the application.



- Users can reset to the default setting by tapping **Reset setting**.

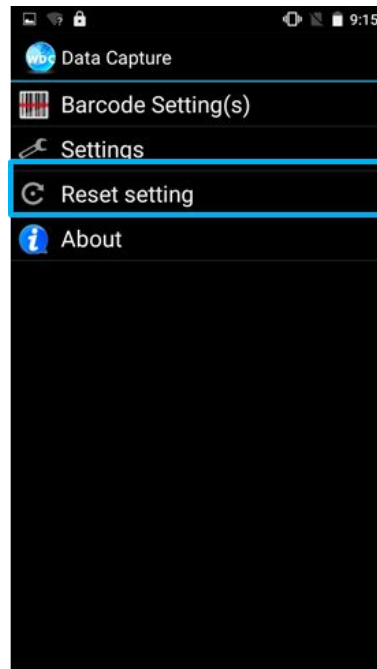

Scanning the barcode

How to scan the barcode?

- Press the function button to trigger the barcode.
- Aim the barcode.
- Ensure the entire barcode is within the rectangular area formed by the brackets in the laser framing.

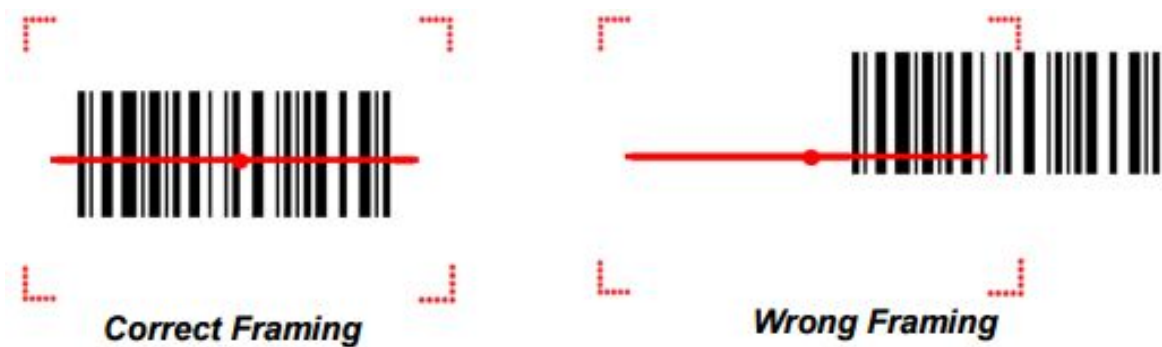

- Release the trigger.

Scanning Tips and Considerations

Distance

Scanning device will decode perfectly over a certain working range, there are minimum and maximum distance from the barcode. To specify the appropriate working range per barcode type is through a table as follows.

Symbology	Density	Min Distance	Max Distance
Code 39	0.100 mm	9.5 cm	11.5 cm
	0.125 mm	8.0 cm	14.5 cm
	0.500 mm	6.5 cm	50 cm
	1.000 mm	9.5 cm	75 cm
EAN / UPS 100%	0.33 mm	6 cm	34 cm
DataMatrix	0.18 mm	7.5 cm	16.5 cm
	0.25 mm	6.0 cm	23.0 cm
	0.38 mm	5.5 cm	34.5 cm
PDF417	0.25 mm	5.5 cm	26 cm
	0.38 mm	6.5 cm	37 cm

Angle

Scanning angle is important for promoting quick decodes.

Scanning Angle	Horizontal 34.4°	34.4°
	Vertical	22.2°
Framing Angle	Horizontal	30°
	Vertical	20°

Using Smart Card Reader

This chapter explains how to use Smart Card Reader. Notice that Smart Card Reader is an optional feature for E500RM8 PDA and may not be present in your device.

Location

Smart Card Reader is located on the bottom side of the E500RM8.

Smart Card Reader
(Optional)

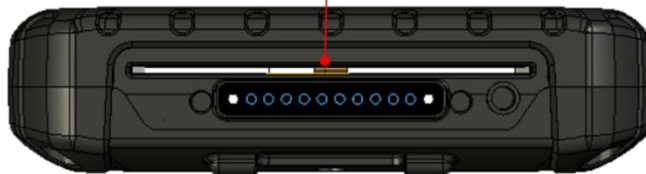

How to Use Smart Card Reader

1. Enter **Settings** menu, and enter select “**Accessibility**”, and then uncheck “**Connect to PC**”.

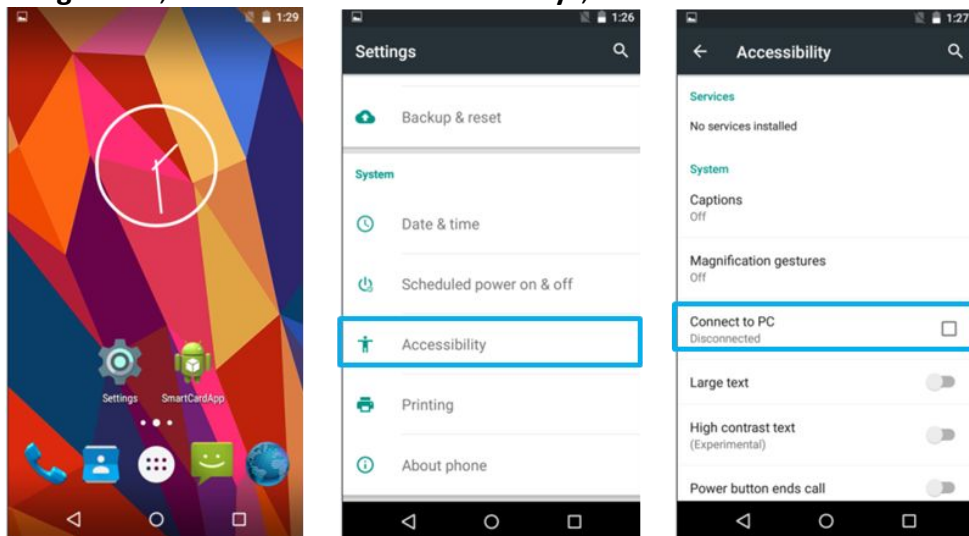

2. Launch the **SmartCardAP**”, select **List Reader**, and then press open.

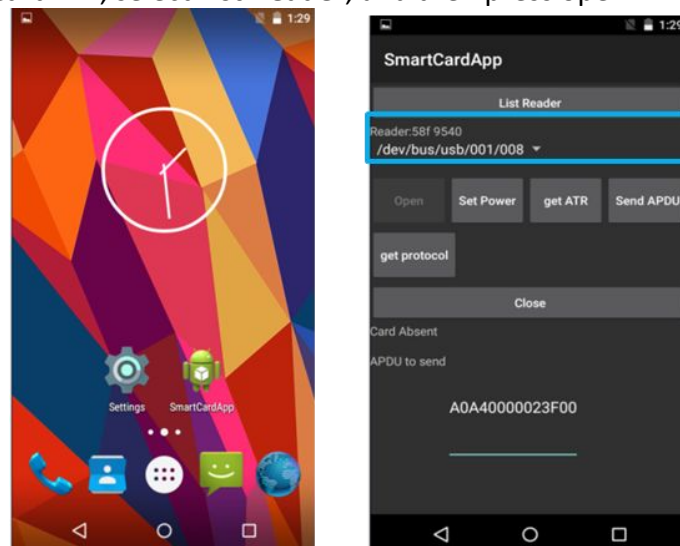

If can't find the reader information, please go back to Step 1 then check and uncheck “**Connect to PC**” again.

3. Insert the Smart Card (IC face to rear) then select “**Set Power**” and select **power on**. Press **Get ATR** to see the information written on the card.

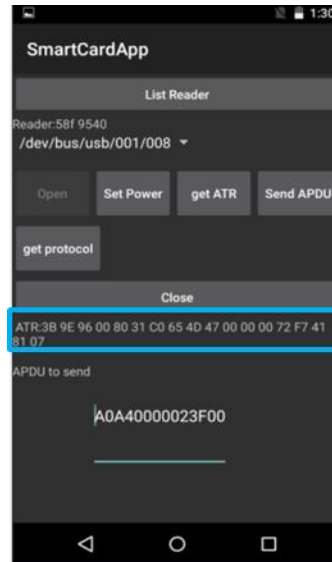

Smart Card Reader SDK

You can download Smart Card Reader SDK from Winmate Download Center or Partner Portal. For more details on Winmate’s SDK refer to [Appendix C](#).

Using Fingerprint Scanner

This chapter explains how to use Fingerprint Scanner. Notice Fingerprint Scanner is an optional feature for E500RM8 PDA and may not be present in your device.

Location

Fingerprint Scanner is located on the top rear side of the E500RM8.





Chapter 7 Accessories

E500RM8 accessories provide a variety of product support capabilities. Some of the accessories are optional and are not included to standard packaging list.

Standard Accessories

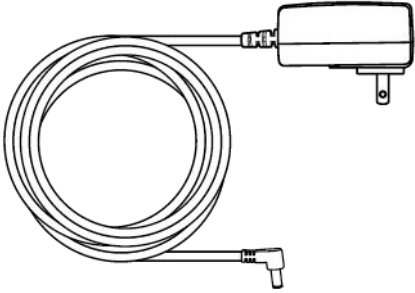
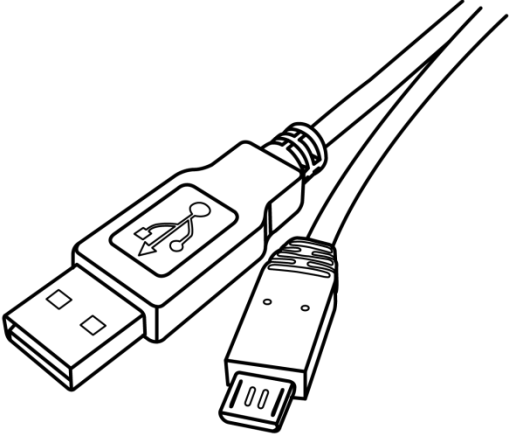
E500RM8 Standard Accessory List:

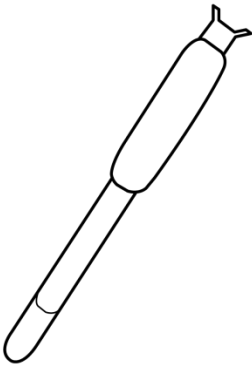
	
<p>*Universal USB Adapter Input: AC 100-240V 50/60 Hz Output : 5V-2A</p>	<p>Micro USB Cable</p>
	
<p>Micro SD Card (4GB)</p>	<p>Hand Strap</p>

**Universal USB Adapter socket varies by country and region. E500RM8 will be shipped with the socket according to your order.*

Power Adapter

Power Adapter allows charging the E500RM8 from the power source. To charge the E500RM8 connect power adapter to the E500RM8 from one side and plug in the socket to the power outlet.

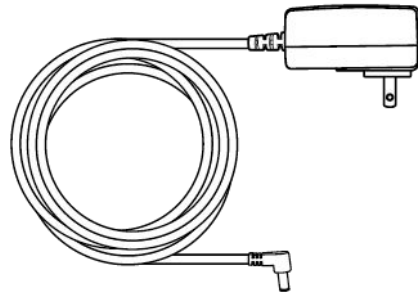

Power Considerations:

Input: AC 100-240V 50/60 Hz

CAUTION Output : 5V-2A

Micro USB Cable

Micro USB Cable provides power to the E500RM8 and USB communications with a host computer. To connect Micro USB cable to E500RM8, open the rubber cover on the right side and insert the cable to micro USB connector.

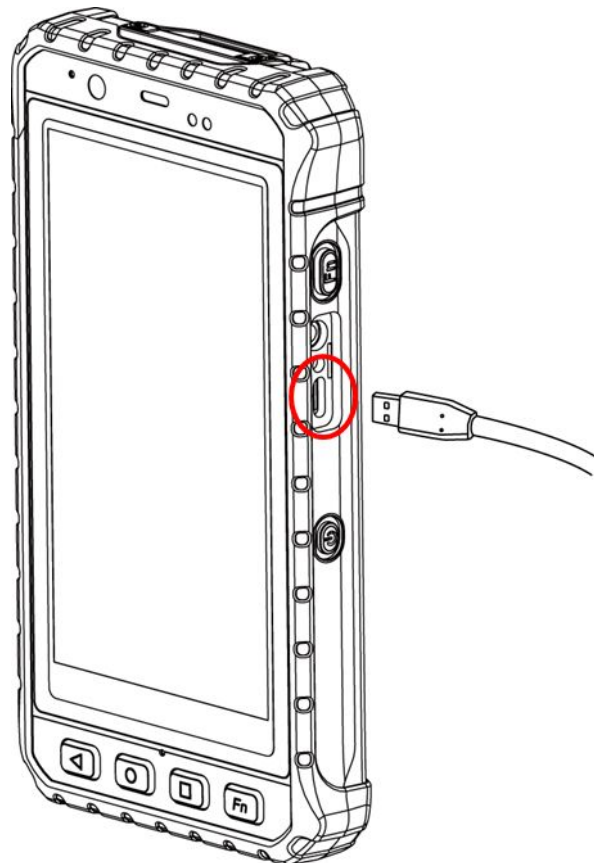

Micro SD Card

Micro USB Card slot is located on the rear side of E500RM8. To access it press two latches up and remove the battery.

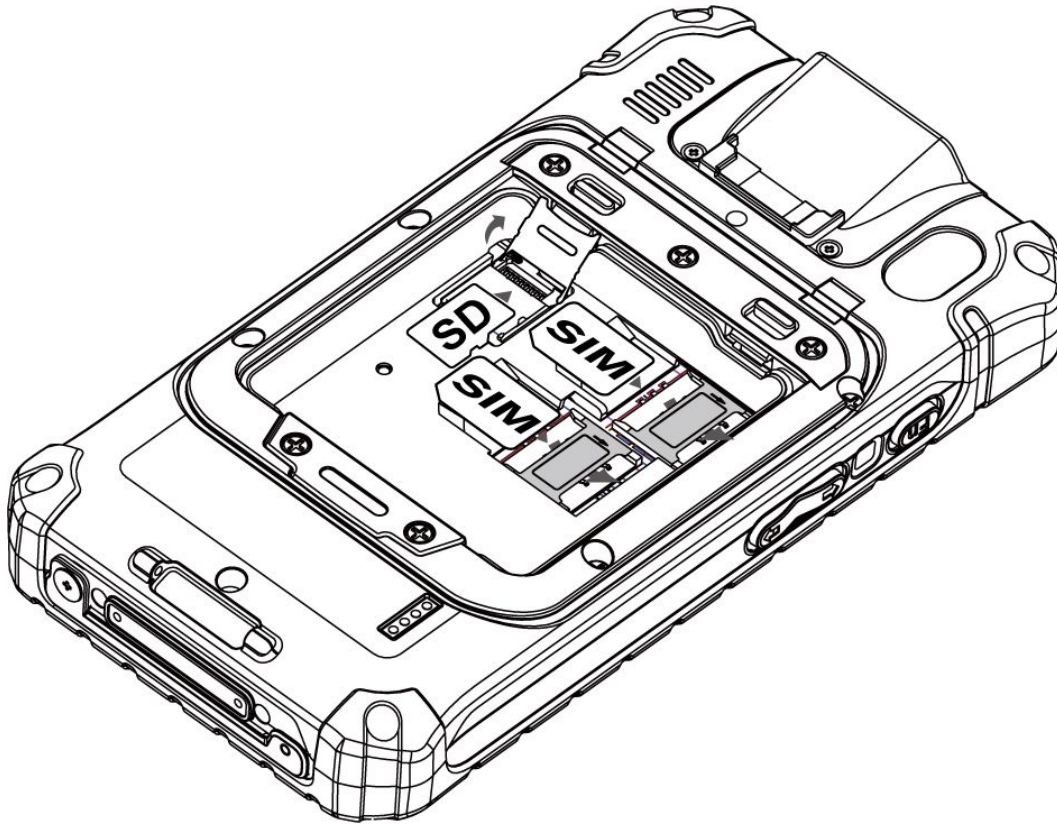

For Micro SD Card installation instructions, refer to [Chapter 1, “SD Card Installation”](#) of this User Guide.

Hand Strap

Hand strap to firmly grasp the device without having the fear of dropping it.

To install hand strap:

1. Place the E500RM8 face-down on a flat surface. Attach the hand strap plate to the upper retaining bar.
2. Insert another side of the hand strap to the under bar.
3. Place your hand under the hand strap to adjust the fit.
4. Then fold the hand strap over and press down firmly to attach the hooks and loops, as shown at the illustration.

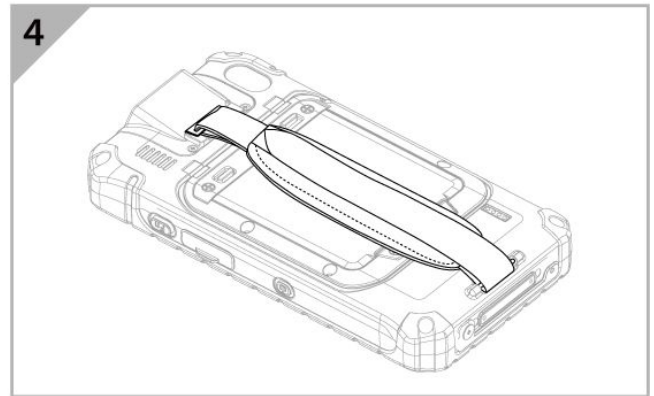
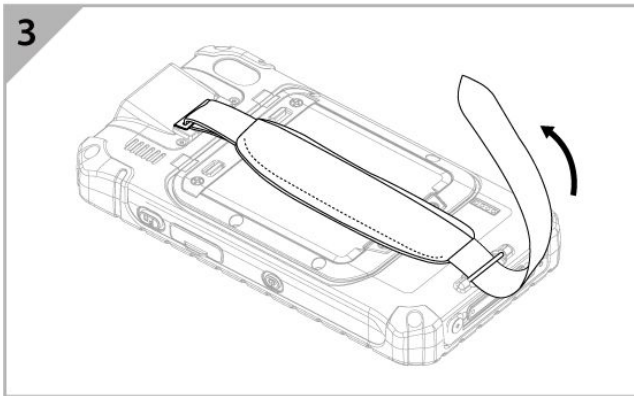
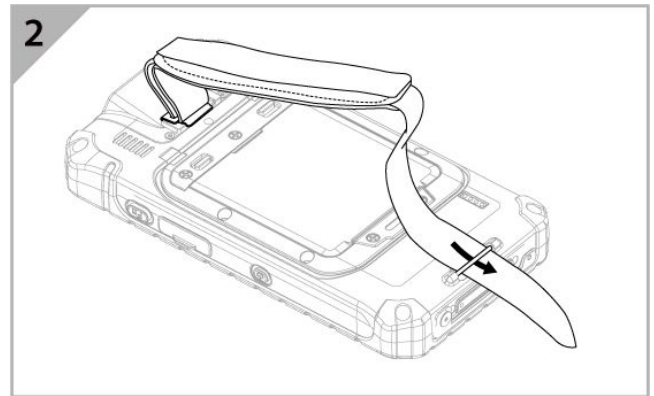
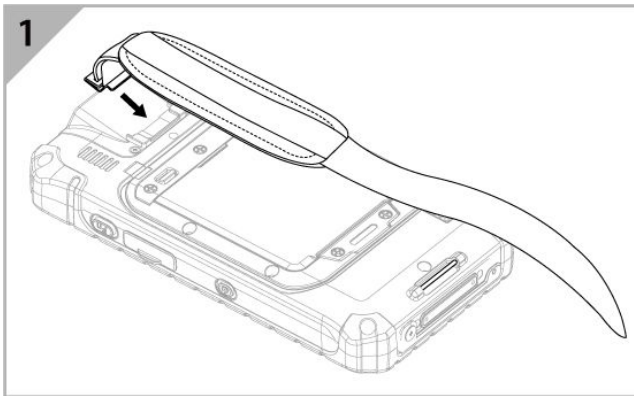

Optional Accessories

E500RM8 Optional Accessory List:

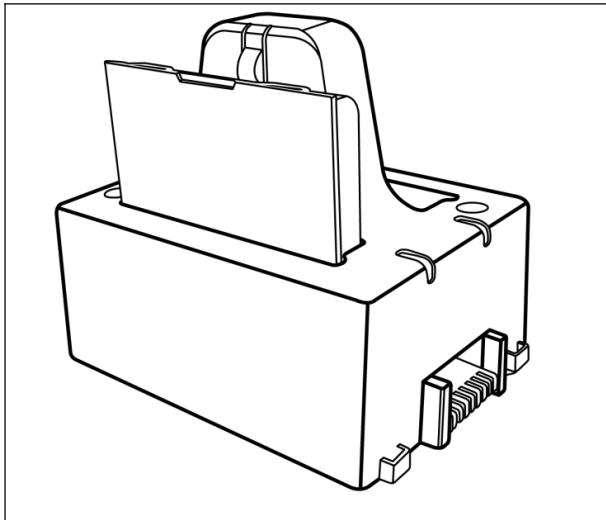

Two Slot Battery Charger
Model name: BD-E430R

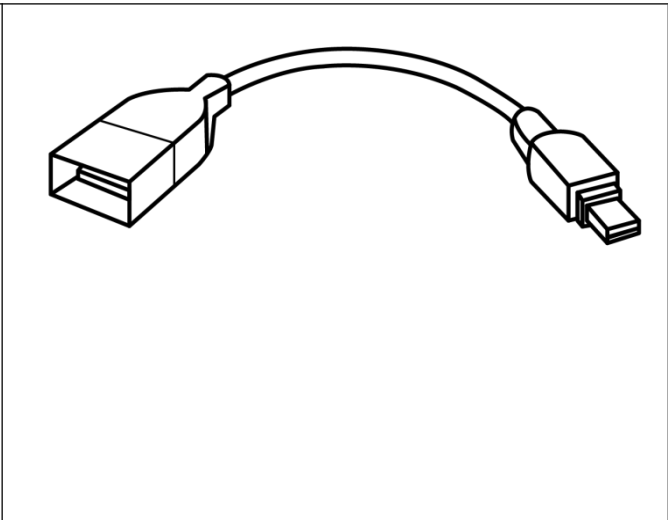

**Micro USB Host Cable
(OTG Cable)**

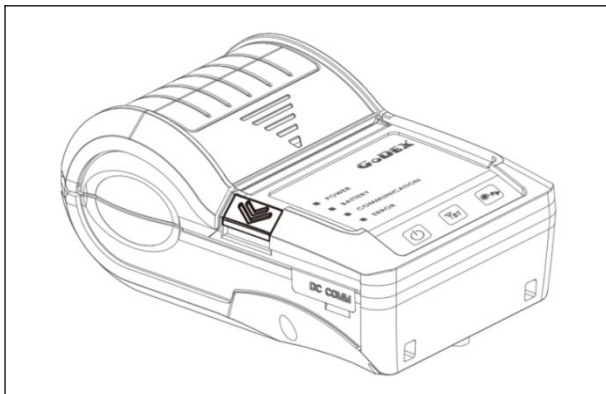

Mobile Printer MX20

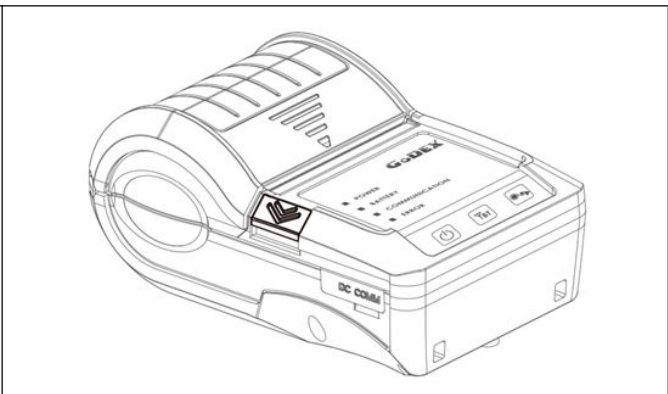

Mobile Printer MX30

Two Slot Battery Charger

The battery charger allows charging up to two battery units simultaneously, ensuring you will never be stuck in-between charges.

2 x charging slots	PoGo Pin type
2 x LED light	Shows current power level
1 x DC in	12V / 50W DC in
Buzzer	4-level volume control

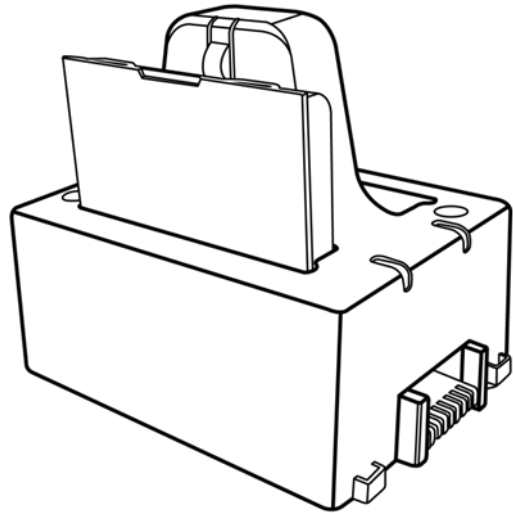

Refer to [Chapter 2, “Charging the Battery”](#) for detailed instructions on charging the battery using docking.

Micro USB Host Cable (OTG Cable)

The USB Host cable OTG (On-the-Go) function is to act as a host allowing a USB flash drive to be attached.

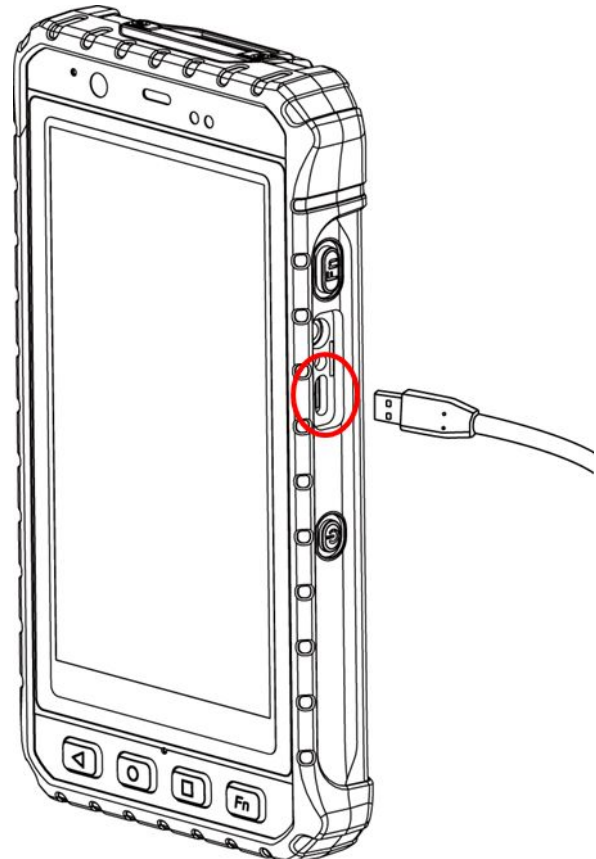

Mobile Printer

Mobile printer allows to print labels and stickers directly from E500RM8.

Model Name	
MX20	MX30
<ul style="list-style-type: none"> • Print width: 1.89-inch (48mm) • Drop & Fit label installation design • IP54 water / dust resistant and 1.5M shock resistant • Supports both wire (RS232 and USB ports) • Long standby time up to 72 hours or 300 label; cycles between charges 	<ul style="list-style-type: none"> • Print width: 2.8-inch (72mm) • Supports multiple label width & types • Drop & Fit label installation design • Water and dust resistant meeting IP54 standard • Versatile interfaces with both wire (RS232 and USB) & wireless (Bluetooth) connectivity.

You need to use Bluetooth to pair the Mobile Printer with E500RM8.

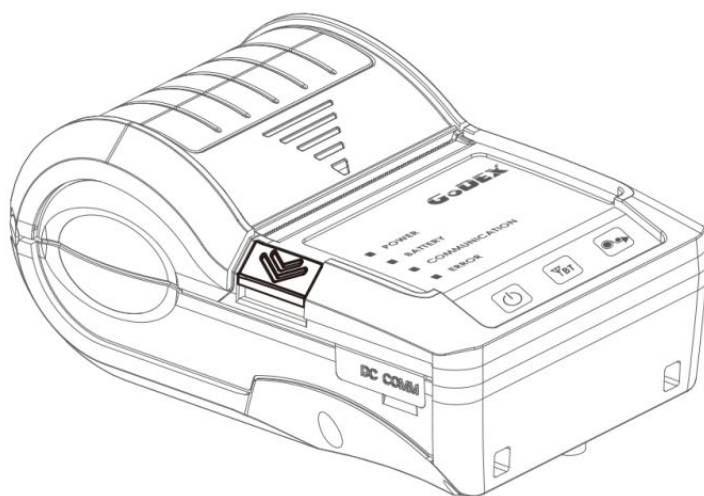

Appendix A: Product Specifications

		Model Name
		E500RM8
Display Specification	Size	5"
	Resolution	1280 x 720
	Brightness	500 (typ.)
	Touch	Projective Capacitive Multi-touch
System Specification	Processor	ARM® Cortex™-A53 Octa-core 1.3GHz
	System Memory	2GB RAM
	Storage	16GB eMMC
	Operating System	Android 5.1 Lollipop
Wireless Communications	WLAN	802.11 b/g/n
	Bluetooth	Bluetooth 4.0
	GPS	GPS / AGPS / GLONASS
System I/O Buttons Indicators Sensors Security	Audio	2 x Built-in Mic
	External I/O	1 x Micro SD card slot 1 x Micro USB 1 x Power Jack 1 x Docking Connector
	Buttons	1 x Volume - + 1 x Power button 2 x Function button 4 x Front Key
	LED Indicators	1 x LED indicator
	Sensors	Light Sensor, Proximity Sensor, G-sensor, Digital Compass
	Data Capture	Camera
Data Capture		<ul style="list-style-type: none"> • 1D/2D Barcode Reader (<i>Optional</i>) • Smart card reader, ISO 7816 part 1,2,3 (<i>Optional</i>) • Fingerprint Reader (<i>Optional</i>)

Appendix A Product Specifications

Mechanical and Environment	Operating Temp.	-20°C ~ +60°C (AC Mode) -10°C ~ +50°C (Battery Mode)
	IP Proof	IP65
	Shock	MIL-STD-810G Method 516.6 Procedure I
	Vibration	MIL-STD-810G Method 514.6 Procedure I
	Drop	MIL-STD-810G Method 516.6, 4 ft, Free to concrete
	Dimensions (W x L x H)	85.4x163.22x22.5 (mm)
	Weight	315g
Power Management	Battery	3.7V 3900mAh Li-ion battery
	Battery Operating Time	20Hr * based on the full-loading
	Adapter	5V 2A Adapter

** Note: measured at dimming LCD brightness. Varies depending on the usage conditions, or when an external device is attached.*

***Note: all specifications are subject to change without prior notice.*

Appendix C: Software Development Kit

Winmate® provides the following drivers for E500RM8.

Item	File Type	Description
1	E500RM8 Drivers	Android Debug Bridge(ADB) Driver / USB Driver
2	E500RM8 Flash Tool	Flash Tool

Winmate® provides Software Development Kit (SDK) for E500RM8.

Item	File Type	Description
1	General SDK (WDC)	Development kit for WDC, including Barcode Reader and Fingerprint Scanner
2	Smart Card Reader SDK	E500RM8 Smart Card Reader SDK - Android Development Kit

Download SDK from Winmate Download Center or Winmate File Share.

1. Winmate Download Center:

<http://www.winmate.com>>Support > Download Center >Industrial PDA>E500RM8 > Development Kit / Drivers

Or follow the link:

<http://www.winmate.com/DownCenter/DownLoadCenter.asp?DownType=2021&OnlyContent=>

2. Winmate File Share

<http://www.winmate.com>>Support>Partner Portal>Public Documents>Industrial PDA> E500RM8 > Development Kit / Drivers

Or follow the link: <https://winmate.box.com/v/E500RM8>

Appendix D OS Image Update

Winmate provide OS Image update tool. Refer to “OS Image Update Tool Guide” for a detailed instruction on how to update OS image.

Download OS Image update tool and OS Image Update Tool Guide from Winmate Download Center or Winmate File Share.

1. Winmate Download Center:

<http://www.winmate.com>>Support > Download Center >Industrial PDA>E500RM8 >OS Image

Or follow the link:

<http://www.winmate.com/DownCenter/DownloadCenter.asp?DownType=2021>

2. Winmate File Share

<http://www.winmate.com>>Support>Partner Portal>Public Documents>Industrial PDA>E500RM8 > OS Image

Or follow the link: <https://winmate.box.com/v/E500RM8>



Winmate Inc.

9F, No.111-6, Shing-De Rd., San-Chung District,
Taipei 241, Taiwan, R.O.C

Tel: 886-2-8511-0288

Fax: 886-2-8511-0211

Email: sales@winmate.com.tw

Official website: www.winmate.com