

**WINPLUS®**

# LED CEILING LIGHT

ITM. / ART. 1165831  
Model: LM56123

## CARE & USE INSTRUCTIONS

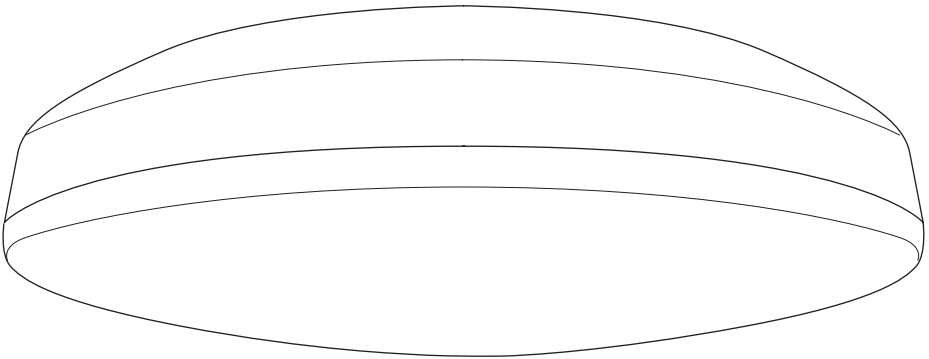

## **IMPORTANT, RETAIN FOR FUTURE REFERENCE: READ CAREFULLY**

For assistance with assembly or installation, parts and customer service, call us at 1-866-294-9244 (English),  
Monday - Friday, 8am - 5pm Pacific Time, email us at [info@winplususa.com](mailto:info@winplususa.com)

820 South Wanamaker Ave., Ontario, CA 91761, USA

[www.winplus.com](http://www.winplus.com)

This LED Ceiling Light is suitable for use in any indoor location (e.g. home, office, warehouse, workshop, garage, and etc.). This light has the following unique features:

- **Built-in Smart Sensor Control System:** This LED Ceiling Light uses a microwave sensor to automatically turn on when motion is detected and will turn off automatically after no movement is detected in the area after the preset (5 min or 30 min) time.
- **Convenient Wireless Remote:** With the remote control, you can easily adjust the light color, brightness, sensor distance, and the timer for auto-off.
- **Adjustable Light Color:** Along with the remote control, you can easily adjust the light color from warm white to cool white for the best fit for your environment.
- **CRI 90:** The high CRI (color rendering index) helps show the object color more naturally and clearly than lights with lower CRI ratings.

### **Important Safety Instructions:**

Please read the following safety information before use.

To reduce risk of fire, electric shock, or injury to persons:

- Turn OFF the main power at the fuse or circuit breaker before installing the light fixture or making any electrical connection.
- Make sure this light fixture is adequately grounded. To ensure proper grounding, there must be a separate ground wire (bare copper) contact between this light fixture and the ground connection of your main power supply panel. Do not connect the bare or green insulation fixture ground wire to the black (hot) current-carrying wire or the white (neutral) wire. Connection of the bare or green fixture ground wire to the black or white wires may cause metal parts of the fixture to carry electrical currents, and may cause electrical shock, which could cause serious injury or death.
- Do not suspend any fixture by the house wires. Suspending a fixture by the house wires and wire connectors may result in the fixture falling, possibly causing personal injury and the danger of electrical shock or fire.
- It is recommended that a qualified electrician perform all wiring connections. All electrical connections must be in accordance with all national and local electrical codes.
- This light fixture is designed for use in a 110 – 120VAC, 60Hz fuse circuit. Not for use on a dimming circuit.
- For indoor use only.

### **Warning:**

- LED light output is strong enough to injure human eyes. Precautions must be taken to prevent looking directly at the LEDs without installing the diffuser (cover) for more than a few seconds.
- If the lighting light fixture is damaged, it shall be exclusively replaced by the manufacturer or the service agent or qualified person in order to avoid a hazard.
- Do not tamper with or attempt to repair the LED component or fixture. The light source is designed for this specific application and should not be serviced by untrained personnel. Contact the customer service department if any servicing is required.
- The warnings, precautions, and instructions discussed in this manual cannot cover all possible conditions and situations that may occur. The operator must understand that

common sense and caution are factors which cannot be built into this product, but must be supplied by the operator.

- Do not install this LED with a dimmer. Doing so may damage the driver inside if used with a dimming circuit.
- This device does not have a plug; rewiring is required. If you are unsure how to rewire this light, please contact a qualified electrician to install instead of attempting to rewire yourself.
- Power will still run to the light even after the LED lifespan runs out. Always shut the power from the fuse (breaker) when conducting any type of maintenance on the light.

## Cleaning:

- Clean the outside of the fixture with a soft, dry cloth or slightly dampened clean cloth. Never use a cleaner with chemicals, solvents, or harsh abrasives to clean the product.
- Do not spray cleaner directly onto any part of the fixture or LEDs as this may permanently damage the light or its functions.

## Package Contains:

Please lay out all parts and read the instructions prior to installation.

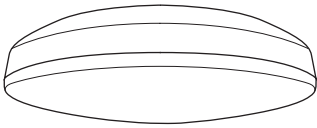

1 x LED Ceiling Light



1 x Wireless Remote



2 x AAA Batteries



2 x Long Mounting Screws



2 x Short Mounting Screws



1 x Crossbar

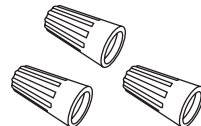

3 x Wire Nuts

Tools Needed (not included):



Phillips-Head Screwdriver

## Before Installation:

Carefully remove the light fixture, mounting package, and wireless remote from the box and check that all parts are included. Do not attempt to assemble the product if any part is missing or damaged.

The outlet box described in this manual is not provided. A standard outlet box needs to be pre-installed in the ceiling, and the power supply wires need to be run to the outlet box providing 120Vac of power. If an outlet box does not exist, contact a qualified electrician for installation.

Please turn OFF the main power at the fuse or circuit breaker before installing the light fixture or making any electrical connection. You may use a non-contact voltage tester to ensure no power running to the wires.

**Warning:** Failure to disconnect the power supply prior to installation may result in serious injury or death.

## Installation Procedures:

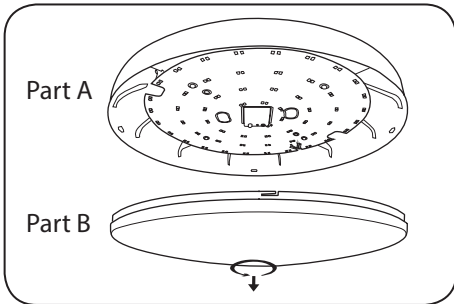

1. Rotate the cover (Part B) clockwise to detach it from the lamp body (Part A).

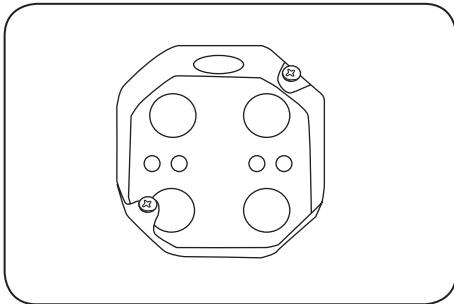

2. Install the long mounting screws into outlet box until there is about  $\frac{1}{2}$  in. between the ceiling and underside of the screw head.

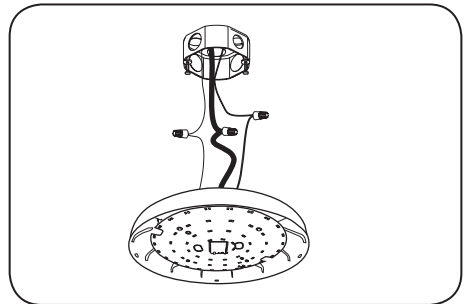

3. Make the following spliced wire connections using wire nuts:

- White (neutral) supply wire to White light fixture wire
- Black (hot) supply wire to Black light fixture wire
- Green (ground) supply wire to Green light fixture wires

Screw the wire nuts in a clockwise direction. Make sure no bare wire or wire strands are visible after making the connections.

Consult with a qualified electrician if you have any electrical questions or if your current power supply does not include a ground wire.

**Warning:** Never connect the ground wire to the black or white power supply wires.

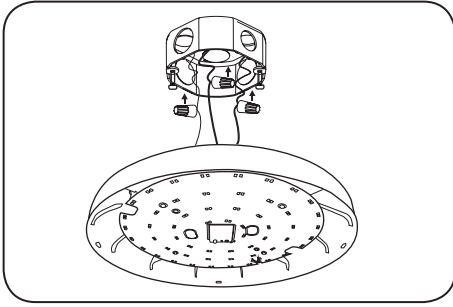

4. Carefully place all the wires and wire connections into the outlet box.

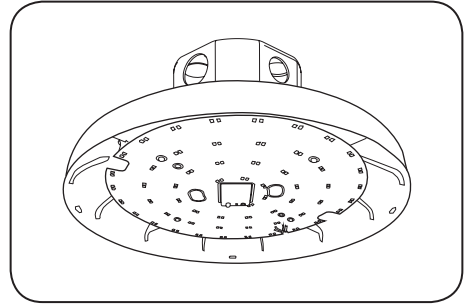

5. Place the lamp body over the outlet box and feed the mounting screws through the inner keyhole slots.

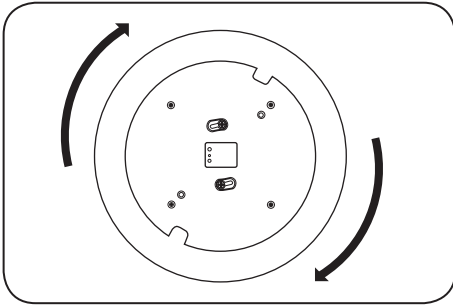

6. Rotate the lamp body clockwise so that the mounting screws slide into the narrow ends of the keyhole slots.

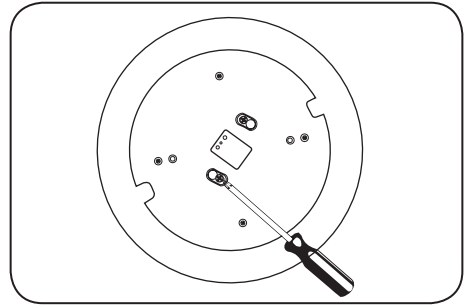

7. Tighten the mounting screws to ensure the lamp body is secured against the ceiling.

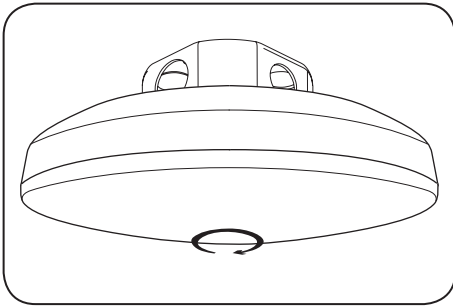

8. Attach the cover to the lamp body, and rotate the cover counter-clockwise to secure in place. To ensure complete securement, please rotate the cover until you cannot rotate further.

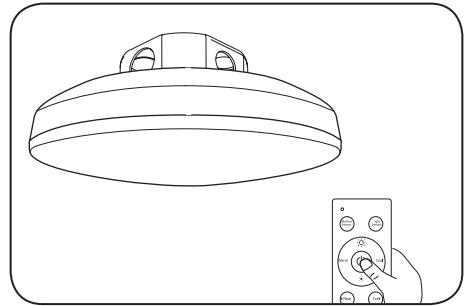

9. When the installation is finished, you can turn on the main power and the light will turn on. If the light does not turn on, please refer to the Troubleshooting section of this manual.

# Wireless Remote:

Before use, please open the switch cover on the back of the remote, and insert two AAA batteries.

When using the remote, you must point the remote directly to the light, to ensure the signals can be sent to the light. When the light receives the remote signal, the light will blink once so that you will recognize it.

## Remote Setting:

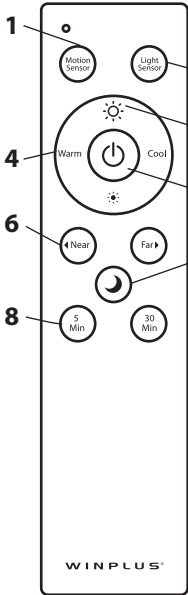

### 1. Motion Sensor

You can press the Motion Sensor button to switch ON (green indicator) or OFF (red indicator).

ON: The light will automatically turn on when motion is detected and will turn off automatically when there is no movement in area for preset time.

OFF: The light will be function as an ordinary light to operate manually through the Remote or wall switch.

The motion sensor indicator (Green/Red) will flash whenever you press other remote buttons, to reflect the status of motion sensor.

### 2. Light Sensor

You can press the Light Sensor button to switch ON (green indicator) or OFF (red indicator).

ON: When the ambient surrounding is bright, the light will stay OFF even if motion has been detected. When the surrounding is less bright and there is motion detected, the light will turn on. The light will turn off automatically when there is no further movement during the preset time.

OFF: The light turns on and off accordingly to Motion Sensor setting, and is not affected by surrounding light.

The light sensor indicator (Green/Red) will flash whenever you press other remote buttons, to reflect the status of light sensor.

NOTE: If the Motion Sensor is turned OFF to disable the motion sensor feature, the Light Sensor feature will also automatically be turned OFF. In this case, the light must be turned on with the Remote or wall switch.

### 3. Brightness

You can adjust the brightness from 10% to 100% full brightness, by pressing continuously the brightness buttons. Press the top brightness button to increase the brightness, and press the down button to decrease the brightness.

### 4. Color Temperature

You can adjust the color temperature from 2700K to 5000K, by pressing continuously the color temperature buttons. Press the left color temperature button for a warmer color temperature, and press the right button for a cooler color temperature.

## 5. Power Button

You can press the power button to turn light on and off accordingly.

NOTE: When you press power button to turn light off while the Motion Sensor function is set to ON, the light will turn ON automatically again when there is motion detected.

## 6. Distance

Distance is the sensor detection area of the smart sensor. You can choose from various settings: Very near, Near, Mid-range and Far. The sensing distance would be ranged from around 1 m / 3.2 ft to 8 m / 26.2 ft. You may refer to the table below for the maximum sensing distance for the light installed at a height of 3 m / 9.8 ft.

Setting	Maximum Sensing Distance (D)	Blink(s) on Motion Sensor Button
Very near	1 m / 3.2 ft - 2 m / 6.5 ft	1 time
Near	2 m / 6.5 ft - 3.5 m / 11.4 ft	2 times
Mid-range	3.5 m / 11.4 ft - 5 m / 16.4 ft	3 times
Far	5 m / 16.4 ft - 7 m / 22.9 ft	4 times

By pressing the Near button, you can change to a shorter distance. By pressing the Far button, you can change to a longer distance.

For example:

- Current setting: Near
- If press "Near" once, the setting will be changed to "Very Near", and the Motion Sensor button will blink 1 time as indication.
- If press "Far" once, the setting will be changed back to "Near", and the Motion Sensor button will blink 2 times as indication.

Any movement inside the detection zone will be detected by the motion sensor. Actual sensing distance may be influenced by environment conditions.

For example, the sensing distance decreases in an open area free of objects. The distance increases in an area with lots of metallic objects.

## 7. Night Mode

By pressing the Night Mode button, the brightness will change to 20% of full brightness. The color temperature will be kept the same.

## 8. Motion Sensor Time Until Off

Motion Sensor Time Until Off is the time for the light to turn OFF completely when there is no motion detected. You can choose either 5 min or 30 min.

The light will be turned OFF when there is no motion detected within the preset time. When choosing 5 min, the light will be dimmed down to 50% of current brightness when no motion has been detected for 4 minutes and the light will be turned OFF when no motion is detected 1 further minute.

When choosing 30 min, the light will be dimmed down to 50% of current brightness when no motion has been detected for 29 minutes and the light will be turned OFF when no motion is detected 1 further minute.

Any movement detected within this period will restart the timer and the light will be turned on again.

## Product Specifications:

1. Operating Voltage: 120Vac, 60 Hz
2. Maximum wattage: 22 W
3. Maximum Light Output: 1700 lm
4. Color Temperature: 2700K – 5000K
5. LED Life Cycles: up to 50,000 hrs\*
6. CRI: 90

\*Note: 50,000-hour lifespan is for the LED only. Lifespan depends on operating temperature, environmental conditions, etc.

## Troubleshooting:

Problem	Possible Cause	Solution
Light does not illuminate.  Light does not turn on.	LED light burned out.	Replace the LED Ceiling Light
	Power is off.	Make sure power supply is on. Ensure the circuit breaker is in the on position as well.
	Faulty wire connection	Check wiring to ensure all wires are correctly wired and are wired securely
	Faulty switch	Test and/or replace switch
Light does not turn on during the day.	Make sure the Light Sensor feature is not enabled (only allowing the light to turn on when the background light is darker).	Turn Light Sensor off to disable this feature.
Fuse blows or circuit breaker trips when light is illuminated.	The wires are crossed (not wired properly) or the power wire is grounding out.	Turn power to the light off from the breaker. Check the wires to ensure the wires were properly connected. If everything looks correct, contact a qualified electrician to check your wires.
Light settings cannot be changed from the remote.	Batteries not inserted correctly.	Open the battery compartment cover and confirm the batteries were inserted correctly. Replace with new batteries if needed.
	Batteries are out.	Replace with two new AAA batteries.
	Remote control is out of range	Move closer to the LED Ceiling Light to select changes from the remote.



# Warranty:

## Winplus North America

This Winplus product carries a 1 year warranty against defects in workmanship and materials. This product is not guaranteed against wear or breakage due to misuse and/or abuse.

**NOTE:** Warranty only applies for North American customers of purchases made in North America.

## Conditions of Warranty

If during the 1 year warranty period your new product is found to be defective, Winplus North America will repair such defect, or replace the product, without charge for parts or labor subject to the following conditions:

- All repairs must be performed by Winplus North America.
- All warranty claims must be accompanied by a copy of the sales receipt or bill of sale.
- The equipment must not have been altered or damaged through negligence, accident, improper operation, or failure to follow the product instructions for installation, use, or care.
- The replacement of parts is excluded from the warranty when replacement is necessary due to normal wear and tear.
- Repair or replacement parts supplied by Winplus North America under this warranty are protected only for the unexpired portion of the original warranty.
- This is a “repair or replace” warranty only, and does not cover the costs incurred for the installation, removal or reinstallation of the product.

**OWNER’S RESPONSIBILITIES:** Winplus North America will make every effort to provide warranty service within a reasonable period of time. SHOULD YOU HAVE ANY QUESTIONS ABOUT SERVICE RECEIVED OR IF YOU WOULD LIKE ASSISTANCE IN OBTAINING SERVICE, PLEASE CALL TOLL FREE 1.866.294.9244 DURING REGULAR BUSINESS HOURS MONDAY THROUGH FRIDAY 9:00 AM TO 5:00PM PST.

**NOTE:** Toll Free # is for North America Customers ONLY. See Customer service section for customer contact numbers for other regions/offices.

For customer service and technical support, please call us at 1.866.294.9244 or email us at [info@winplususa.com](mailto:info@winplususa.com). If at that time it is determined that a replacement unit is needed, the support representative will issue a Return Authorization and instruct on how to get a new unit.

Winplus North America makes no other warranty of any kind aside from the limited express warranty stated herein.

DISCLAIMER OF WARRANTIES, INCLUDING WARRANTY OF MERCHANTABILITY AND WARRANTY OF FITNESS FOR PARTICULAR PURPOSE: EXCEPT AS SPECIFICALLY SET FORTH HEREIN, NO WARRANTY OR REPRESENTATION, EXPRESS OR IMPLIED, IS MADE AS TO THE LED SHOP LIGHT. EXCEPT AS EXPRESSLY SET FORTH HEREIN, WINPLUS NORTH AMERICA AND/ OR ITS AFFILIATES EXPRESSLY DISCLAIMS, WITHOUT LIMITATION, ANY STATUTORY WARRANTIES AND ALL IMPLIED WARRANTIES, INCLUDING ANY IMPLIED WARRANTY OF MERCHANTABILITY OR FITNESS FOR A PARTICULAR PURPOSE.

## **FCC / IC Compliance Statement:**

This device complies with Part 15 of the FCC rules and Industry Canada license-exempt RSS standard(s). Operation is subject to the following two conditions: (1) this device may not cause harmful interference, and (2) this device must accept any interference received, including interference that may cause undesired operation.

Warning: Changes or modifications to this unit not expressly approved by the party responsible for compliance could void the user's authority to operate the equipment.

The manufacturer is not responsible for any radio or TV interference caused by unauthorized modifications or change to this equipment. Such modifications or change could void the user's authority to operate the equipment.

This equipment has been tested and found to comply with the limits for a Class B digital device, pursuant to part 15 of the FCC Rules. These limits are designed to provide reasonable protection against harmful interference in a residential installation. This equipment generates, uses and can radiate radio frequency energy and, if not installed and used in accordance with the instructions, may cause harmful interference to radio communications. However, there is no guarantee that interference will not occur in a particular installation. If this equipment does cause harmful interference to radio or television reception, which can be determined by turning the equipment off and on, the user is encouraged to try to correct the interference by one or more of the following measures:

- Reorient or relocate the receiving antenna.
- Increase the separation between the equipment and receiver.

- Connect the equipment into an outlet on a circuit different from that to which the receiver is connected.

- Consult the dealer or an experienced radio/TV technician for help.

The device has been evaluated to meet general RF exposure requirement.

To maintain compliance with FCC's RF exposure guidelines, this equipment should be installed and operated with a minimum distance of 20cm between the radiator and your body.

DISTRIBUTED BY:  
COSTCO WHOLESALE CORPORATION  
P.O. BOX 34535  
SEATTLE, WA 98124-1535, USA  
TEL: 1-800-774-2678  
[www.costco.com](http://www.costco.com)

MADE IN CHINA



Have a comment or question? Email us at [info@winplususa.com](mailto:info@winplususa.com)  
or visit us online at [www.winplus.com](http://www.winplus.com)

**WINPLUS®**

820 South Wanamaker Ave., Ontario, CA 91761, USA | Tel: 1-866-294-9244

© 2017 Winplus North America Inc. All rights reserved.