

iTeknic **BH003**

**NORTH AMERICA**

E-mail: [Support.US@iTeknic.com](mailto:Support.US@iTeknic.com)

US Distributor: SUNVALLEYTEK INTERNATIONAL INC.

Address: 46724 Lakeview Blvd, Fremont, CA 94538

**JAPAN**

E-mail: [support.jp@iTeknic.com](mailto:support.jp@iTeknic.com) (JP)

Address: Kyoubasihigasi 9F, 3-18-6 PMO, Hatchobori, Chuo-ku,  
Tokyo, 104-0032, Japan.

**EUROPE**

EU Importer: SOURCE CONNECTION LTD

E-mail: [Support.UK@iTeknic.com](mailto:Support.UK@iTeknic.com) [Support.DE@iTeknic.com](mailto:Support.DE@iTeknic.com)

[Support.FR@iTeknic.com](mailto:Support.FR@iTeknic.com) [Support.ES@iTeknic.com](mailto:Support.ES@iTeknic.com)

[Support.IT@iTeknic.com](mailto:Support.IT@iTeknic.com)

Address: The Coach House, 1 Howard Road, Reigate,

Surrey, England, RH2 7JE, UK

Manufacturer

Address: Shenzhen NearbyExpress Technology Development Company  
Limited 333 Bulong Road, Shenzhen, China, 518129

iTeknic

## User Guide

TRUE WIRELESS STEREO EARPHONES

**BH003**

[www.iteknic.com](http://www.iteknic.com)

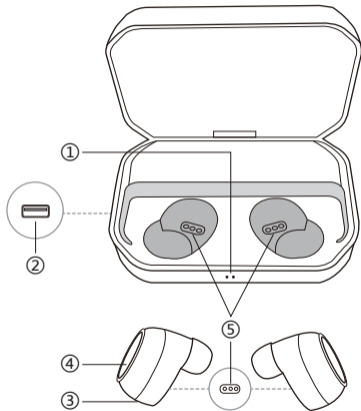

**EN**

**Product Diagram**

1. Charging Indicators
2. USB Output Port
3. LED Indicator
4. Multi-Function Buttons
5. Charging Contacts

**DE**

**Produktabbildung**

1. Ladeanzeigen
2. USB-Ausgang
3. LED-Anzeige
4. Mehrfunktionale Drucktaste
5. Ladekontakte

**FR**

**Schéma du Produit**

1. Voyants de Charge
2. Port de Sortie USB
3. Voyant à LED
4. Bouton Multifonction
5. Contacts de Charge

**ES**

**Diagrama del Producto**

1. Indicador de Carga
2. Puerto de Salida USB
3. Indicador LED
4. Bóton Multifuncional
5. Contactos de Carga

**IT**

**Schema del Prodotto**

1. Indicatori di Ricarica
2. Porta in Uscita USB
3. Indicatore LED
4. Tasto Multifunzione
5. Contatti di Ricarica

**JP**

**製品図**

1. 充電表示
2. USB出力ポート
3. LED表示
4. 多機能ボタン
5. 充電面

**EN**

## DANGER:

This product contains lithium battery. Never expose it to strong sunlight or toss it into fire to avoid explosion.

## Package Contents

- 1 x Charging Case
- 2 x Earbuds
- 1 x USB Charging Cable
- 6 x Ear Tips (two are equipped on the earphones)
- 1 x User Manual

## How to Use How to Wear

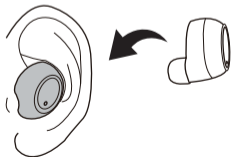

## Charging Charging the Earbuds

Put the earbuds into the charging case properly, and charging will start automatically. The LED indicator will flash blue slowly during charging and will turn off once fully charged.

## Charging the Charging Case

Connect the Micro USB charging port with any USB output port, and charging will start automatically. The charging indicators will light up progressively.

### Note:

- Never use excessive force on charging components.
- Please charge the earbuds and the charging case before first time use or after a long time idle.

## Pairing

### Couple Earbuds Mode

· Take out the earbuds from the charging case, and they will connect with each other automatically with the blue light and the red light flashing at the same time (If the earbuds failed to enter the pairing mode, please press and hold the control button for 2 seconds). Once connected, The LED indicator on the left earbud is off, and the blue LED indicator on the right earbud is on for 2 seconds.

· Turn on the Bluetooth function on your device and search for nearby devices. At this time, the red and blue light of the earbuds will alternately flash slowly. Find "iTeknic IK-BH003" in the searching results. Click the name to connect. Once connected, the LED indicators on both earbuds will flash blue for 2 seconds.

If the pairing failed, the blue light will flash slowly, and the earbuds will automatically shut down after 10 minutes.

Put the earbuds back into the charging box and they will disconnect automatically and start charging. If the mobile phone is disconnected or out of Bluetooth range, a new pairing will be performed.

### Single Earbud Mode

· Take out one of the earbuds from the charging case, and the LED indicator will flash red and blue. Press the control button twice to bring the earbud into pairing mode.

· Turn on the Bluetooth function on your device, search for nearby devices. Find "iTeknic IK-BH003" in the searching results and click the name to connect.

**Note:**

If you want to change from Couple Earbuds Mode to Single Earbud Mode, you need to put both earbuds back into the charging box at the same time, then the earbuds will automatically shut down, (If the earbuds failed to turn off automatically, press and hold the control button for 6 seconds, then put it back in the charging box) and take both earbuds out from the charging case to pair.

## Operation and Functions

Function	Operation
Answer / Hang Up Phone Call	Press the Control Button on either of the earbuds once to Answer; Press the Control Button on either of the earbuds twice to Hang Up Phone Call.
Reject Incoming Call	Hold pressing the control button on either of the earbuds for 2 seconds
Previous Track	Press the control button on the left earbud three times
Next Track	Press the control button on the right earbud three times
Play / Pause	Press the control button on either of the earbuds twice
Volume -	Press the control button on the left earbud once
Volume +	Press the control button on the right earbud once
Turn On / Off Voice Control	When paired successfully, press and hold the control button on either of the earbuds for 2 seconds to activate Siri, or activate it with a voice command. Click to exit the Voice Dial state and return to the previous state.

#### Note:

1. If your earbuds cannot be paired with each other, please follow the instructions below to restore the factory settings: press and hold the two control buttons on the earbuds for 11 seconds, then turn the earbuds back on. At this time, the earbuds will directly enter the pairing mode. During the cleaning process, the purple light will light for 3 seconds.
2. Extra attention is needed when wearing the earbuds to avoid accidental pressing of the control button.
3. When restoring to factory settings, please pay close attention to the status of the LED indicators for accurate settings.
4. It is not recommended to wear the two earbuds on different people. If need to do so, please keep the 2 earbuds within 9.8ft in couple earbuds mode.
5. The volume cannot be adjusted in single earbud mode.
6. Charging box: When the power is less than 10%, the red LED indicator will flash three times every 10 minutes. When the power is less than 3%, the red LED indicator will flash three times every 2 minutes. When the charging box is charging with earbuds in, the LED indicator will turn into purple at this time.

7. When the mobile phone has connected to the earbuds with music playing through Bluetooth, if there is incoming call, the music will stop and the mobile phone will play the incoming call ringtone. When the calling hangs up, the phone will automatically revert to the previous phone music via Bluetooth earbuds.
8. Low battery reminder. When the battery is less than 10%. You will be prompted that the battery needs to be charged. You will be reminded every 5 minutes.
9. Power synchronization display: Supports IOS/Android mobile phone battery power synchronization indication.
10. When the remaining battery power is less than 10%, you will be prompted that the battery needs to be charged. You will be reminded every 5 minutes.  
When the charging box is charging the earbuds, the blue light is on. It will turn off when the charging is complete.  
When the charging box is charging without earbuds in, the red light is on. It will turn off when the charging is complete.

## FAQ

Q: Failed charging of the charging case.

A: Make sure the charging cable is intact and plugged in properly.

Q: Signal of the earbuds is unstable and there is no sound in the earbuds.

A: Please wear the earbuds properly and put your phone in the front pocket when using it outdoor.

Q: Two devices named "iTeknic IK-BH003" are found.

A: Delete both names and search again.

Q: Sound is unclear.

A: Increase the volume slowly on your phone and earbuds and keep them close to each other.

Q: How to connect one earbud to two phones in single earbud mode?

A: 1. Connect your first phone with the earbud, turn off its Bluetooth function.

2. Connect your second phone with the earbud, turn on the Bluetooth on your first phone.

Q: What's the effective range between the two earbuds?

A: Around 3 meters / 9.8 feet.

## Warning

- Never dismantle or refit the product to avoid malfunction or fire hazards.
- Keep away from corrosive liquids to avoid damages to the product.
- Keep away from extreme temperatures.
- Keep away from children and pets.
- Don't use the product in thunderstorm weather to avoid malfunction or electric shock.

#### NOTE:

This equipment has been tested and found to comply with the limits for a Class B digital device, pursuant to part 15 of the FCC Rules. These limits are designed to provide reasonable protection against harmful interference in a residential installation. This equipment generates uses and can radiate radio frequency energy and, if not installed and used in accordance with the instructions, may cause harmful interference to radio communications. However, there is no guarantee that interference will not occur in a particular installation. If this equipment does cause harmful interference to radio or television reception, which can be determined by turning the equipment off and on, the user is encouraged to try to correct the interference by one or more of the following.

measures:

- Reorient or relocate the receiving antenna.
- Increase the separation between the equipment and receiver.
- Connect the equipment into an outlet on a circuit different from that to which the receiver is connected.
- Consult the dealer or an experienced radio/TV technician for help

Changes or modifications not expressly approved by the party responsible for compliance could void the user's authority to operate the equipment. This device complies with Part 15 of the FCC Rules.

Operation is subject to the following two conditions:

(1) this device may not cause harmful interference, and(2) this device must accept any interference received, including interference that may cause undesired operation.



**EN** The Bluetooth® word mark and logos are registered trademarks owned by the Bluetooth SIG, Inc. and any use of such marks by Sunvalleytek International Inc. is under license. Other trademarks and trade names are those of their respective owners.

**DE** Die Marke Bluetooth® und das Bluetooth Logo sind eingetragene Markenzeichen der Bluetooth SIG, Inc. und jegliche Verwendung dieser Marke durch Sunvalleytek International Inc. ist lizenziert. Die Rechte an anderen Markenzeichen liegen beim jeweiligen Eigentümer.

**FR** Le terme et les logos Bluetooth® sont la propriété de Bluetooth SIG, Inc. et toute utilisation de ces marques par Sunvalleytek International Inc. se fait sous licence. Les autres désignations commerciales et marques mentionnées sont détenues par leur propriétaire respectif.

**ES** La marca Bluetooth® y los logotipos son de propiedad de Bluetooth SIG, Inc. y se encuentra autorizado cualquier uso de estas marcas por parte de Sunvalleytek International Inc. Otras marcas y nombres comerciales son aquellas de sus respectivos propietarios.

**IT** La parola e i loghi Bluetooth® sono marchi di fabbrica registrati di proprietà di Bluetooth SIG, Inc. e qualsiasi utilizzo di questi marchi da parte di Sunvalleytek International Inc. avviene su licenza. Gli altri marchi di fabbrica e nomi commerciali appartengono ai rispettivi proprietari.

**JP** Bluetooth®のワードマークおよびロゴはBluetooth SIG, Inc.が所有する登録商標であり、Sunvalleytek International Inc.はこれらのマークおよびロゴをライセンスに基づいて使用しています。その他の商標およびトレードネームは、それぞれの所有者に帰属します。