

PRELIMINARY



Wireless Bypass

DL-5800

5.8 GHz U-NII Wireless CABLE ACCESS SYSTEM

Technical & Installation Manual

I
N
S
T
A
L
L
A
T
I
O
N



O
P
E
R
A
T
I
O
N

PRELIMINARY

Proprietary Notice

This information and design disclosed herein was originated by and is the property of Wireless Bypass, Inc. Wireless Bypass reserves all patent proprietary design, manufacturing, reproduction use, and sales rights thereto, and to any article disclosed therein, except to the extent rights are expressly granted to others. The foregoing does not apply to vendor proprietary parts.

Specifications are typical and subject to change without notice, in order to allow the introduction of design improvements.

Wireless Bypass has carefully reviewed the information herein and it is believed to be accurate and reliable. However, no responsibility is assumed for inaccuracies or errors. Use of this information and/or any of our products does not convey to the user any patent rights or licenses. Wireless Bypass reserves the right to change any specifications or information contained herein without notice.

Wireless Bypass products are not to be used in life support applications without the expressed written consent of Wireless Bypass.

Wireless Bypass
43 Northwestern Drive
Salem, N.H. 03079 USA
www.wireless-bypass.com

Worldwide Sales & Service:
TEL: 603-870-6222
FAX 603-870-6279

Copyrighted (c) 2000
Wireless Bypass
Salem N.H. 03079

Printed in the U.S.A.

Safety Precautions

RF Energy Radiation Warning

The radio equipment described in this guide uses radio frequency transmitters. Although the power level is low, the concentrated energy from a directional antenna may pose a health hazard operated incorrectly. All devices must be installed by qualified installation / deployment personnel, and a minimum of 1.5 meters of separation must exist between the device and persons, when the device is operating. The device installers and operators should be aware of the transmitter operating conditions specified in the Wireless Bypass DL-5800 installation manual and other associated user documentation, as well as the antenna co-location requirements of Part 1.1307 (b) (3), of FCC rules, pertaining to RF exposure.

Protection from Lightning

Article 810 of the US National Electric Department of Energy Handbook 1996 specifies that radio and television lead-in cables must have adequate surge protection at or near the point of entry to the building. The code specifies that any shielded cable from an external antenna must have the shield directly connected to a 10 AWG wire that connects to the building ground electrode.

Regulatory Notices:

Canada:

Operation is subject to the following two conditions: (1) this device may not cause interference, and (2) this device must accept any interference, including interference that may cause undesirable operation of the device.

To reduce potential radio interference to other users, the antenna type and its gain should be so chosen that the equivalent isotropic radiated power (EIRP) is not more than that required for successful communication.

United States:

CAUTION: Modifications to this device not expressly approved by Wireless Bypass may cause the device to exceed regulatory standards and therefore VOID the user's authority to operate the device.

This device complies with Part 15 of the FCC rules. Operation is subject to the following two conditions: (1) this device may not cause

PRELIMINARY

interference, and (2) this device must accept any interference received, including interference that may cause undesirable operation.

System Description

Wireless Bypass Cable Access Radio Systems are high performance, wireless, microwave communication links that provide an efficient solution for Cable Modem data transmission requirements. These systems operate in the unlicensed 5.8 GHz U-NII band between 5.725 & 5.825 GHz. The Wireless Bypass DL-5800 Series U-NII Cable Access Radio enables cable operators to expand their cable service market by delivering high-speed Internet service to customers previously inaccessible with the installed HFC network.

The Wireless Bypass system described in this manual consists of a HUB radio frequency unit, and a CPE (Customer Premise Equipment) radio frequency unit. Several different antenna configurations may be described for point-to-point, or point-to-multipoint operation. In multipoint configurations, many CPE's may be used with one HUB.

The HUB connects to the installed HFC network using standard cable drop techniques. The HUB contains all the signal processing necessary to transmit the downstream IP data into the coverage area and insert the upstream data bursts into the HFC network.

The CPE is a small radio transceiver installed at the customer site that provides the downstream data and a return connection for the customer's cable modems to the HFC network.

The Antenna system used will be determined by the desired coverage area and network topology. Two basic Antenna systems may be used with the DL-5800: Point-to-Point, and Point-to-Multipoint. DL-5800 distance capability will range from about 2 miles in a Point-to-Multipoint implementation, and up to 20 miles for Point-to-Point. Basic main lobe antenna patterns are show below.

*****INSERT ANTENNA PATTERNS HERE*****

Equipment Design Features

Wireless Bypass's radio systems provide patent pending advanced designs, incorporating a high level of circuit integration to achieve lower power consumption per terminal, and higher reliability for longer MTBF. Microprocessor-based intelligent monitoring of vital performance functions provides extensive diagnostics that are summarized to provide a single point red LED indicator, which will illuminate in the event of a malfunction.

PRELIMINARY

The highly integrated design of the Wireless Bypass DL-5800 series radio systems provide the user with a cost-efficient radio that is easily installed and maintained. The DL-5800 incorporates programmable synthesized Voltage Controlled Oscillators to allow the user to configure VHF mapping frequencies in the field with a minimum of test equipment. This feature allows flexibility when accessing different downstream frequencies.

Gain control switch settings and VHF monitor port allow the installer to easily and accurately configure the CPE in minimum time.

The HUB and CPE are both enclosed in a durable EMI shielded cast aluminum housing that contains the modular radio frequency components. The HUB and CPE can be wall or pole mounted near the antenna, or mounted integral with the antenna, thus minimizing signal loss. The housing is equipped with an "N" connector that connects to the antenna with a short cable, and an "F" connector that connects to the cable.

The flexibility of the Wireless Bypass DL5800 radio system provides for a variety of point-to-point, and point-to-multipoint system configurations. See examples shown in figure 1-1 and figure 1-2.

System Configurations

*******INSERT application figures HERE*******

Figure 1-1 DL-5800 Typical applications

Figure 1-2 DL-5800 Typical applications

Figure 1-3 Channel Plan FCC Part 15.401, IC RSS-210 LE-LAN

Unpacking and Handling

Examine the condition of the shipping containers. If any of the shipping containers is damaged, a description of the damage should be noted on the carrier's receipt.

Do not open the containers. Immediately make arrangements with the carrier to have their agent present when the cartons are opened.

Wireless Bypass will not accept responsibility for shipping damage.

Before opening the shipping containers, locate the packing slip attached to the outside of one of the containers.

Carefully remove the equipment from the container to prevent damage to the unit. Ensure that all parts are identified and checked against the packing list.

Do not discard the container or any packing material until inspection has been completed. This material must be available if a damage claim is to be made with the carrier.

If any containers are missing, notify the carrier immediately.

Damage in Shipment

Mechanically inspect the equipment for shipping damage. Make sure that the equipment is clean and dry, and no connectors, controls, indicators, or other parts are broken, damaged or loose.

Should any damage be discovered after unpacking the equipment, immediately file a claim with the carrier. A full report of the damage should be made and a copy forwarded to Wireless Bypass. The company will then advise disposition of the equipment.

Recommended Tools and Equipment

The following tools and test equipment (not supplied) are recommended for installation of the equipment:

VHF Level Meter (Hukk CM1000 Digital Signal Analyzer)

For waveguide and mechanical work:

Miscellaneous flat blade and Phillips type screwdrivers

Set of combination open end/box wrenches, 1/4 to 3/4 inch

These tools are useful when preparing coaxial connectors:

Wire stripper

Open and box end wrenches

Soldering iron or crimping tool

Knife

Miscellaneous test cables and adapters as required to interface with test equipment

Safety and Installation Precautions

The following suggestions are presented as reminders to prevent injury to installers or damage to equipment during installation of the DL-5800 microwave radio.

Electrical Shock

These precautions are not intended as an all-inclusive instructional guide. This installation should be made by qualified service personnel and must follow all local and national codes. Normal safety practices must be followed at all times. Do not operate the equipment unless it is properly grounded.

Do not operate the equipment if any electrical connectors or wires are worn, frayed or exposed.

Do not connect or remove any electrical connections when power is applied to this equipment.

Do not operate this equipment unless the correct circuits protecting fuses or circuit breakers are installed and functioning properly.

Radiation

Do not attempt any repairs on components within this equipment with power applied.

Although this equipment does not present a radiation danger when properly operated, the following precautions are recommended:

Do not operate the transmitter if anyone is within two (2) feet in front of the antenna.

Do not operate the transmitter unless all RF connectors are properly terminated.

Do not stand in front of or look into an open waveguide or antenna feed.

Electro-Static Discharge

The following precautions should be taken:

Always wear a grounding strap when handling electronic components.

PRELIMINARY

Electronic components or assemblies should not be handled in a high static environment (i.e., carpeted, warm or dry environment).

Electronic assemblies should be handled by the edges avoiding electrical contacts.

Equipment should always be stored and shipped in protective packing materials.

Equipment Grounding

Wireless Bypass Microwave Radios must be properly grounded to prevent damage to the equipment from lightning surges or signal transmission problems due to ground loops. Wireless Bypass recommends that installers follow standard grounding practices such as those employed by telephone companies while observing all local and national codes. This section includes:

Lightning Surge Protection
Verify All Connections
AC Power Grounding Hints
Input Power Cables

Lightning Surge Protection

Although all Wireless Bypass radios are equipped with surge protection, it is necessary to ground outdoor equipment and interconnection cables using commercially available grounding kits. Install the grounding kits as follows:

1. On the radio housing or on the antenna to the tower or mast.
2. To the interconnection cables at the base of the tower or just before cables enter the building.

Verify all Connections

Verify all wiring and connections. It is common practice to have someone other than the installing technician verify the wiring. The RF output of the transmitter must be terminated to the antenna or a suitable RF load. If the antenna is connected, it should be visually aligned before the application of power. It is not necessary to connect the data interface signal before applying power.

AC Power Grounding Hints

Having more than one AC ground point on the radio does not mean that an AC ground loop will exist. Ground loops occur when the ground path impedance provided by the shield on the signal & power cables between the indoor equipment and radio is low compared to the path provided by the electrical wiring ground at the site.

In these instances, AC current will flow along the signal cable shield inducing a voltage potential between the indoor and outdoor equipment. In extreme cases this voltage can exceed the AC power input of the system or cause an under voltage condition. To remedy ground loop problems, either break the AC ground path to the radio, or provide a low resistance ground path between the two AC ground points connecting the indoor equipment and DL-5800.

Environmental Considerations

Wireless Bypass DL-5800 Specifications for Operating and Non-operating conditions are listed in the following table:

Specification	Minimum	Maximum
Temperature, operating	-30° C	+50°C
Temperature, non-operating & storage	-45°C	+75°C
Altitude, operating & non-operating	N/A	50,000 feet AMSL

Installation Planning

In addition to planning the path profile, the physical location of the equipment and proper grounding techniques need consideration. This section covers these procedures that concern the DL-5800, and the associated installation.

General Site Survey

In order to receive a signal, the CPE antenna must be pointed directly at the HUB, without obstructions between the two antennas. Consider the possibility of future building projects, home remodeling and additions, or tree growth. The DL-5800 signal will **NOT** pass through buildings!

Do NOT mount the equipment at the very top of a mast where it would be subject to direct lightning strikes.

Finding the Pointing Coordinates

Aligning the HUB or CPE antenna using visual sightings is, of course, the easiest method. However, for longer paths this is often not very practical.

A more practical approach is to use computer-mapping programs such as Topo! ® or a topographical map to obtain exact coordinates (azimuth and elevation) for pointing the antennas.

In point-to-multipoint applications the HUB antenna has a broad field, and should be oriented to serve multiple CPE sites. In point-to-point systems where the distances are much further and the antenna beam widths are narrow, obtain the pointing azimuth and elevation settings for each end of the path; record the numbers in a log.

Precise Site Survey

Based on your general site(s) survey, you already know where to mount the DL-5800 components. Go to the exact mounting location for the CPE or HUB.

When a clear path had been identified, review the mounting options for the support structure and DL-5800 components to insure the feasibility of the selected locations.

Cable Requirements

At this point, you have decided on the exact mounting site, and you must now decide on how and where the cable will enter the building, and then determine just how much cable you will need.

Grounding the CPE or HUB to the central building ground helps prevent damage from nearby lightning strikes. Installation must comply with local codes and the National Electrical Code.

PRELIMINARY

Locate the central building ground. You will ground the DL-5800 using a cable lightning arrester type block to a single point in the central building ground.

Acceptable grounding is:

- Grounded interior cold water metal pipes within five feet of where it enters the building.
- Grounded metallic service box.
- Eight foot ground rod driven at least six feet into the ground (only if connected to central building ground using #6 or heavier ground cable).
- Acceptable grounding mechanisms that comply with sections 810 and 250 of the National Electrical Code.

Choose a place to mount the lightning arrester. The block must be as close as possible to the place where the cable will enter the building. Decide where the customer equipment will be located inside the building.

Estimate the amount of cable you will need for:

- One RG-6 coax cable with messenger ground wire to run from the CPE (or HUB) to the grounding block. The lightning arrester must be located near the cable entry point of the building.
- One RG-6 coaxial cable to run from the lightning arrester to the power tap.
- One RG-6 coaxial cable to run from the power tap to the interface equipment.

Grounding cable (#10 copper or #8 aluminum) to run from the grounding block to the central building grounding point.

Antenna Selection & Installation

Proper care must be taken to select and install U-NII band antenna to insure that FCC guidelines are met under all circumstances.

IT IS THE RESPONSIBLITY OF THE INSTALLER TO MEET REGULATORY EMMISIONS REQUIREMENTS

Only antennas that have been certified by the FCC for operation with the DL-5800 may be used. Contact Wireless Bypass for instructions if the desired antenna is not on the following list:

MFG	MFG PN	TYPE	GAIN (dBi)	HOZ BW	VER BW	USE
Telex	5830AA	Omni Directional	7.5	360	15	P-MP
Cushcraft	S57212AMP10SMF	Flat Panel	12	58	27	P-MP
Telex	5840AA	Flat Panel	15	90	8	P-MP
Radio Waves	SEC-5H-16-90	Flat Panel	16	90	8	P-MP
Gabreil	DFPD.5-52	Flat Panel	18	18	18	P-MP
Gabreil	DFPD1-52	Flat Panel	23	9	9	P-MP/P_P
Radio Waves	SP2-5.8	2 ft. parabolic	28	6.2	6.2	P-P
Radio Waves	SP4-5.8	4 ft. parabolic	34.6	3	3	P-P
Radio Waves	SP6-5.8	6 ft. parabolic	37.6	2	2	P-P

RF Exposure Limits

The DL5800 series transceivers and associated antenna shall be installed by qualified personal. Section 1.1310 of the Federal Communication Commission Regulations sets limits on the field strengths and power densities allowable for human exposure. To comply with Radiofrequency exposure requirements, the antennas used for the DL5800 series shall be installed to provide a minimum distance of 1.5 meters where persons may have access.

Antenna Warning

A label or sign containing the following language shall be placed on or near the antenna and visible from at least 1.5 meters:

CAUTION: To comply with RF exposure requirements, this antenna must be installed to provide a separation distance of at least 1.5 meters from all persons.

PRELIMINARY

Installation is to be performed by qualified service personnel and must conform to all local and national codes. Read the Commercial Warranty provisions (section 10.0) contained in this manual before installing the equipment. Additionally, the FCC and IC dictate that proper installation required to meet emission regulations is the responsibility of the installer, not the equipment manufacturer.

Wireless Bypass Microwave Radios are completely tested at the factory before shipment. However, the installer must perform certain procedures provided in this section of the manual before operating the system. Review system diagrams prior to installation.

Mounting the DL-5800 Radio System Components

HUB (head end) TRANSCEIVER

- **Obtain and Mount the Support Structure for the Transceiver and Antenna** – Examples are depicted below. Detailed mounting instructions are supplied by the mount manufacturer.

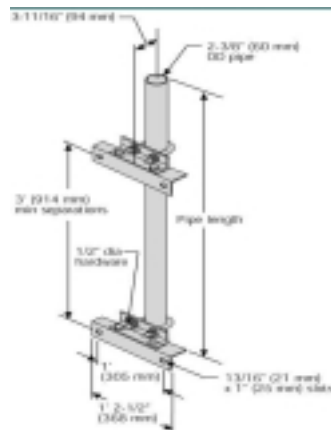

Wall mount

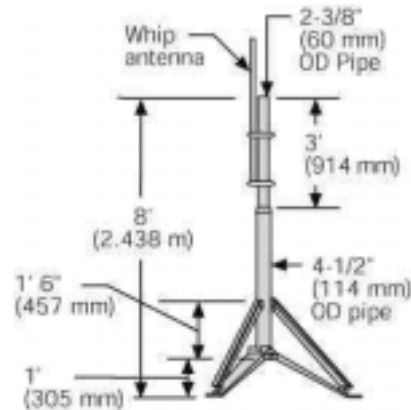

Tripod Mount

- **Install the mounting bracket assembly**, (shown below), to the mounting support structure taking care to orient the transceiver mounting tang in such away as to facilitate connection of the cable plant coax and the coax antenna feed. The mounting bracket will accommodate pipes from 2 3/8 to 4 1/2 in. OD

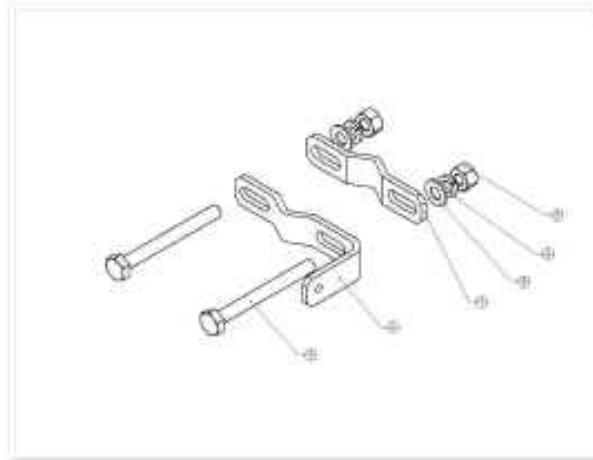

- **Mount the antenna to the support structure**; use the mounting directions supplied by the antenna manufacturer, taking care to set the azimuth and elevation of the antenna for the best coverage of the CPE's.

PRELIMINARY

- **Connect the coax from the antenna to the Transceiver**, avoid sharp bends and take proper steps to waterproof all connectors.
- **Complete the DL-5800 Assembly** – Attach the transceiver to the mounting structure. And connect the coax to the transceiver, waterproof the connector as above.
- **Route Coax Cable to the lightning arrester**– Attach a lightning arrester to the building and connect coax cable from the DL-5800 to the lightning arrester. Route grounding wire to the central building ground.

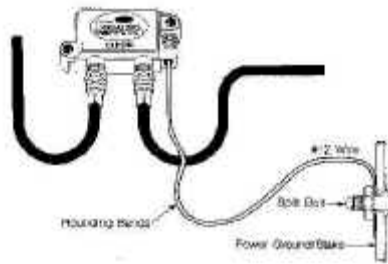

- **Route Coax to the cable plant** – Route the coax cable from the lightning arrester to the to the HFC Network tap. The correct cable tap value must be selected to provide +20dBm (+0, -3dBm) to the Hub as measured at the cable input connector. Verify that the proper signal levels and primary voltages are present; remove access cover on the bottom of the transceiver and set dip switches to the positions dictated by the antenna, frequencies and network topologies.

Point to Point HUB TRANSMITTER POWER SWITCH SETTINGS

Antenna	MFG	Part Number	TX power Switch Settings
2 ft. parabolic	Radio Waves	SP2-5.8	110101
4 ft. parabolic	Radio Waves	SP4-5.8	110110
6 ft. parabolic	Radio Waves	SP6-5.8	101100
Flat Panel	Gabriel	DFFD1-52	111000

Access Panel Configuration Switches

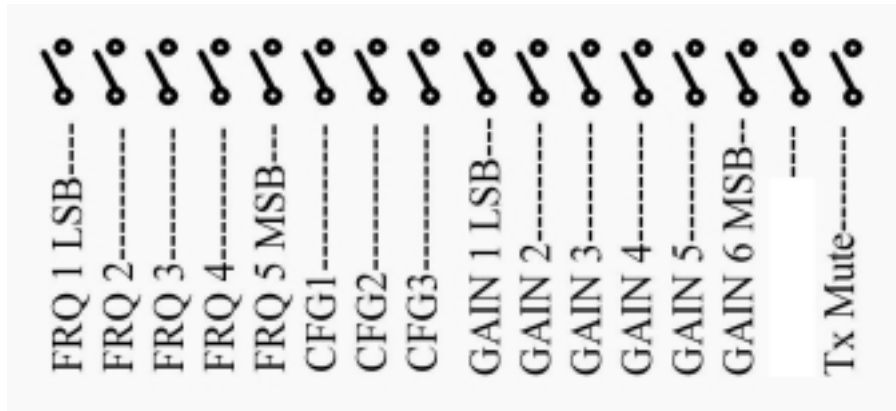

Point to Multipoint HUB TRANSMITTER POWER SWITCH SETTINGS

Antenna	MFG	Part Number	TX power Switch Settings
Omni-directional	Telex	5830AA	111000
Flat Panel	Cushcraft	S57212AMP10SMF	110100
Flat Sector	Radio Waves	SEC-5H-16-90	110000
Flat Panel	Telex	5840AA	110001
Flat Panel	Gabriel	DFPD.5-52	101110
Flat Panel	Gabriel	DFPD1-52	101001

- Set the Downstream mapping selector switches according to the following table; the CATV channel is the downstream center frequency from the cable plant. The mapped frequency is the frequency that will be transmitted to the CPE equipment. Example: downstream signal from cable plant is at 621 MHz (channel 90) and will be mapped to 105 MHz. Choose mapping code

PRELIMINARY

01101. The cable modems attached to the CPE will receive the downstream signal at 105 MHz.

CATV Channel	Center frequency (MHz)	93	99	105	111	117
79	555	00100	00011	00010	00001	00000
80	561	00101	00100	00011	00010	00001
81	567	00110	00101	00100	00011	00010
82	573	00111	00110	00101	00100	00011
83	579	01000	00111	00110	00101	00100
84	585	01001	01000	00111	00110	00101
85	591	01010	01001	01000	00111	00110
86	597	01011	01010	01001	01000	00111
87	603	01100	01011	01010	01001	01000
88	609	01101	01100	01011	01010	01001
89	615	01110	01101	01100	01011	01010
90	621	01111	01110	01101	01100	01011
91	627	10000	01111	01110	01101	01100
92	633	10001	10000	01111	01110	01101
93	639	10010	10001	10000	01111	01110
94	645	10010	10010	10001	10000	01111

- **Apply power to the DL5800** – Verify that the alarm LED, visible through the DL5800 access panel is green. Install the access panel cover plate. Double-check all electrical and mechanical connections.

Standard CPE Installation

- **Attach CPE mounting bracket** taking care to orient the CPE mounting brackets to allow for the necessary pointing adjustments.

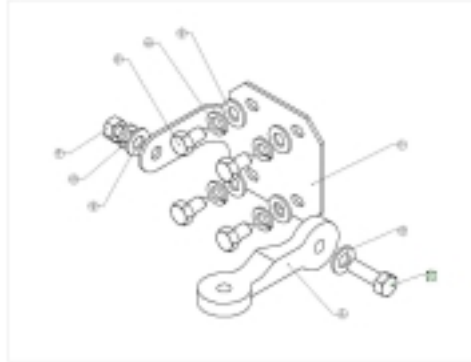

- **Complete the DL-5800 Assembly** – Attach the CPE to the mounting bracket and adjust the Azimuth and Elevation to point the transceiver at the HUB antenna.
- **Attach the coax to the CPE** – Waterproof the connection. Remove the access cover on the bottom of the transceiver and set configuration switches to disable transmitter output. Configure Receiver gain word for approximate gain. **See appendix A**
- **Route Coax Cable to the lightning arrester**– Attach a lightning arrester to the building and connect coax cable from the CPE to the lightning arrester. Route grounding wire to the central building ground.

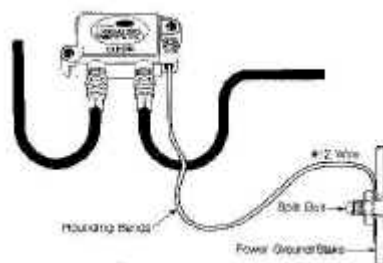

- **Route Coax from the Lightning Arrester to the Power Tap.** Route the coax cable from the grounding block to the power tap. Insure the power tap is correctly oriented to supply power to the CPE. Attach the wall mounted power supply (for the CPE).
- **Fine Tune the Signal Path Peak the Signal and Set CPE Level.** Use a Hukk Signal Meter (or equivalent) connected to the CPE monitor port

PRELIMINARY

to monitor the downstream signal. Adjust CPE antenna to achieve maximum signal strength. Remove the access cover on the bottom of the transceiver and set dipswitches to obtain correct signal output. **See appendix A**

- **Make Final Connections to the Customer Equipment.** Install RG-6 cable from the power tap to the customer equipment. The transmit power setting for the HUB must be properly configured for the selected antenna to insure proper operation and compliance with emission regulations. Power settings vary for point-to-point and point-to-multipoint radio systems. Refer to the appropriate chart below for the correct setting.

Visual Antenna Alignment

Optimum antenna alignment occurs when both the transmitting and receiving antennas are precisely aimed at each other in both azimuth and elevation. Azimuth is the angle in the horizontal plane with respect to true north. Elevation is the angle in the vertical plane with respect to the horizontal plane.

NOTE

Visual antenna alignment provides approximate aiming of the antennas. To perform more accurate and precise final alignment of the antennas, follow the procedure in section *Antenna Final Alignment*

To determine the azimuth angle between the transmitting and receiving antennas, draw a straight line on a map connecting the Transmitter and Receiver sites. If possible, locate a distinct landmark that can be used for a visual reference to align the antennas. If this landmark does not lie directly on this straight line, draw another straight line to this landmark. Using a protractor, measure the angle between the two lines to determine the offset angle. Align the antenna using this offset angle

If no distinct landmarks are available, a magnetic compass may be used for antenna alignment. First, measure the angle between the straight line connecting the two sites and true north. Convert the azimuth to magnetic north using the local declination angle.

If visual elevation alignment is not feasible, then the elevation angle must be calculated to align the antenna. The elevation angle may be calculated by taking the arctangent of the ratio of the difference in height of the two antennas to the distance between antennas.

PRELIMINARY

Antenna Final Alignment

Electrical Alignment is based upon maximizing the Received Carrier Level (RCL) at each antenna. Since the transmit and receive focus of the antenna are the same, the antenna transmit signal is also being aligned in the process

The antenna transmit radiation pattern and the received pattern has a single dominate lobe and multiple side lobes. It is easy to become deceived and incorrectly align the antenna to a side lobe. To be certain that the antenna is NOT aligned on a side lobe, it should be deliberately turned completely through the side lobes while observing the signal strength to identify the difference between side lobes and the main lobe

Start by marking the initial position of the antenna that was set through Visual Alignment, using a suitable marking pen. Connect the Hukk Signal Analyzer to the CPE monitor connector.

2. Move the antenna to the left of Visual Alignment approximately 10 degrees
3. Very slowly move the antenna to the right while watching the level meter reading. Stop and locate each peak in the meter reading, noting the peak reading and marking the antenna position.
4. Continue this procedure until the antenna is moved to a position approximately 10 degrees to the right of Visual Alignment. Record the positions and levels for the main lobe and each of the side lobes.
5. Move the antenna back to the main lobe, peak the alignment, and tighten the mount clamps. Observe the level meter while tightening the clamps to ensure the alignment doesn't change
6. Repeat the above procedure for the elevation adjustment
7. Recheck both the azimuth and elevation alignment a second time.

PRELIMINARY

Notice

This equipment has been tested and found to comply with Part 15 of the FCC Rules. These limits are designed to provide reasonable protection against harmful interference in a residential installation. This equipment generates, uses and can radiate radio frequency energy and, if not installed professionally and used in accordance with the instructions, may cause harmful interference to radio communications. However, there is no guarantee that interference will not occur in a particular installation. If this equipment does cause harmful interference to radio or television reception, which can be determined by turning the equipment off and on, the user is encouraged to try to correct the interference by one or more of the following measures:

* Reorient or relocate the receiving antenna.

* Increase the separation between the equipment and receiver.

* Connect the equipment into an outlet on a circuit different from that to which the receiver is connected.

* Consult the dealer or an experienced radio/TV technician for help.

Shielded cables and I/O cords must be used for this equipment to comply with the relevant FCC regulations.

Changes or modifications not expressly approved in writing by Wireless Bypass may void the user's authority to operate this equipment.

This device complies with RSS-210 of Industry Canada. Operation is subject to the following two conditions: (1) this device may not cause interference, and (2) this device must accept any interference, including interference that may cause undesired operation of the device.

This device is intended to be installed by qualified professional personnel.

GENERAL TERMS

- 1.1 All Definitions contained in Wireless Bypass 's Conditions of Sale (Wireless Bypass document number CS96-8), apply to the Warranty.
- 1.2 Subject to the provisions of the Warranty, Wireless Bypass warrants that the equipment described in Paragraph 1.3 shall conform to their specifications described in Paragraph 1.4 in all material respects and that the equipment shall be free from material defects in materials and workmanship.
- 1.3 This Warranty applies to all original purchases of Wireless Bypass manufactured equipment and accessories (collectively the "Equipment").
- 1.4 This Warranty applies to the specifications contained in the most recent version of the manual for the model of the Equipment purchased (the "Specifications").
- 1.5 This Warranty does not apply to the following items of Equipment which are covered by the Original Equipment Manufacturer's warranty:
 - (a) antenna systems, including coax cable, waveguide, connectors flex-sections, mounts, other parts of the antenna system and installation materials;
 - (b) non-Wireless Bypass manufactured rack mounted equipment that is assembled wired and tested at Wireless Bypass 's factory or supplied as part of a system, including orderwire items, channel banks, multiplexers, fuse/alarm panels, remote alarm items; and
 - (c) equipment which is not listed in Wireless Bypass 's price book.
- 1.6 The effective period of this Warranty shall start on the date of shipment of the Equipment and shall end:
 - (a) for all unlicensed radio products and for all licensed radio products, two (2) years later;
 - (b) for all extended temperature microwave radio products, one (1) year later; or
 - (c) for all other products, two (2) years later (in each case the "Warranty Period").
- 1.7 The Customer acknowledges that Wireless Bypass does not represent or warrant that the services provided by Wireless Bypass under this Warranty will ensure uninterrupted or error-free operation of the Equipment.

PRELIMINARY

RETURN OF EQUIPMENT UNDER WARRANTY

- 2.1 If an item of Equipment malfunctions or fails in normal intended usage and maintenance within the applicable Warranty Period:
- (a) the Customer shall promptly notify Wireless Bypass of the problem and the serial number of the defective item;
 - (b) Wireless Bypass shall, at its sole option, either resolve the problem over the telephone or provide the Customer with a Returned Materials Authorization number (RMA #) and the address of the location to which the Customer may ship the defective item;
 - (c) if the problem is not resolved over the telephone, the Customer shall attach a label to each returned item describing the fault and the Customer's return address. The Customer shall, at its cost, properly pack the item to be returned, prepay the insurance and shipping charges, and ship the item to the specified location;
 - (d) if the Wireless Bypass product shall prove to be defective in material or workmanship upon examination by Wireless Bypass, Wireless Bypass shall either repair or replace the returned item at its sole option. The replacement item may be new or refurbished; if refurbished, it shall be equivalent in operation to new Equipment. If a returned item is replaced by Wireless Bypass, the Customer agrees that the returned item shall become the property of Wireless Bypass.
 - (e) Wireless Bypass shall at its cost, ship the repaired item or replacement to any destination within the United States of America by carrier and method of delivery chosen by Wireless Bypass. If the Customer has requested some other form of conveyance, such as express shipping, or is located beyond the USA borders, then the Customer shall pay to the cost of return shipment.
- 2.2 Equipment that is repaired or replaced by Wireless Bypass under this Warranty shall be covered under all of the provisions of this Warranty for the remainder of the applicable Warranty Period or ninety (90) days from the date of shipment of the repaired item or replacement, whichever period is longer.
- 3.1 Wireless Bypass may immediately terminate this Warranty and all of its performance under this Warranty, upon notification to the Customer, if the Customer:
- (a) makes any unauthorized modifications to the Equipment;
 - (b) assigns or transfers the Customer's rights or obligations under this Warranty without the written consent of Wireless Bypass ;
 - (c) becomes bankrupt or insolvent, or is put into receivership; or
 - (d) has not paid Wireless Bypass all amounts for the Equipment, services, or other additional charges within thirty (30) days of receipt of written notice from Wireless Bypass.
- 3.2 If this Warranty is terminated by Wireless Bypass, the Customer shall remain liable for all amounts due to Wireless Bypass.

FORCE MAJEURE

- 4.1 "Force Majeure" has the same meaning as defined in Wireless Bypass's Conditions of Sale.
- 4.2.1 Wireless Bypass shall not be responsible for failure to discharge its obligations under this Warranty due to Force Majeure.

LIMITATIONS AND QUALIFICATIONS OF WARRANTY

- 5.1 This Warranty does not apply to any damage, defect or failure caused by:
- (a) any part of the Equipment having been modified, adapted, repaired, or improperly installed, operated, maintained, transported or relocated by any person other than Wireless Bypass personnel or a Wireless Bypass authorized service agent, without Wireless Bypass's prior written consent;
 - (b) storage or environmental conditions which do not conform to the applicable sections of the appropriate Wireless Bypass Equipment Manual;
 - (c) failure to conform with the Equipment Installation, Operating and Maintenance Instructions of the appropriate Wireless Bypass Equipment Manual;
 - (d) external causes, including external electrical stress or lightning, or use in conjunction with incompatible equipment, unless such use was with Wireless Bypass 's prior written consent;

PRELIMINARY

- (e) cosmetic damage;
- (f) accidental damage, negligence, neglect, mishandling, abuse or misuse, other than by Wireless Bypass personnel or a Wireless Bypass authorized service agent; or
- (g) Force Majeure.

WARRANTY LIMITATIONS ON DAMAGES (North America)

- 6.1 THE WARRANTY STATED IN THIS DOCUMENT IS THE CUSTOMER'S EXCLUSIVE WARRANTY FOR THE EQUIPMENT; WIRELESS BYPASS SPECIFICALLY DISCLAIMS ALL OTHER WARRANTIES OF ANY KIND, EXPRESS OR IMPLIED, INCLUDING ANY WARRANTIES OF FITNESS FOR A PARTICULAR PURPOSE AND OF MERCHANTABILITY.
- 6.2 WIRELESS BYPASS SHALL NOT BE LIABLE IN TORT, INCLUDING LIABILITY IN NEGLIGENCE OR STRICT LIABILITY, AND SHALL HAVE NO LIABILITY AT ALL FOR INJURY TO PERSONS OR PROPERTY. WIRELESS BYPASS 'S LIABILITY FOR FAILURE TO FULFIL ITS OBLIGATIONS UNDER THIS WARRANTY OR ANY OTHER LIABILITY UNDER OR IN CONNECTION WITH THE EQUIPMENT SHALL BE LIMITED TO THE AMOUNT OF THE PURCHASE PRICE OF THE EQUIPMENT. THE REMEDIES STATED IN THIS WARRANTY ARE THE CUSTOMER'S EXCLUSIVE REMEDIES AGAINST WIRELESS BYPASS REGARDING THE EQUIPMENT.
- 6.3 EVEN IF WIRELESS BYPASS HAS BEEN ADVISED OF THE POSSIBILITY OF THEM, WIRELESS BYPASS SHALL NOT BE LIABLE FOR ANY INDIRECT, INCIDENTAL, SPECIAL OR CONSEQUENTIAL DAMAGES, INCLUDING THE COST OF LABOR BY THE CUSTOMER'S OWN EMPLOYEES, AGENTS OR CONTRACTORS IN IDENTIFYING, REMOVING OR REPLACING THE DEFECTIVE ITEM; LOST PROFITS, AND REVENUES; CUSTOMER WIRELINE ACCESS COSTS; FAILURE TO REALIZE EXPECTED SAVINGS; ANY CLAIM AGAINST A CUSTOMER BY A THIRD PARTY; OR ANY OTHER COMMERCIAL OR ECONOMIC LOSSES OF ANY KIND.
- 6.4 THESE LIMITATIONS AND DISCLAIMERS ARE NOT MADE BY WIRELESS BYPASS WHERE PROHIBITED BY LAW.

LIMITATIONS ON DAMAGES (International)

- 6.1 THE WARRANTY STATED IN THIS DOCUMENT IS THE CUSTOMER'S EXCLUSIVE WARRANTY FOR THE EQUIPMENT; ALL OTHER WARRANTIES OF ANY KIND, EXPRESS OR IMPLIED, INCLUDING ANY WARRANTIES OF FITNESS FOR A PARTICULAR PURPOSE AND OF MERCHANTABILITY ARE EXCLUDED TO THE FULLEST EXTENT PERMITTED BY LAW.
- 6.2 WIRELESS BYPASS 'S LIABILITY FOR FAILURE TO FULFIL ITS OBLIGATIONS UNDER THIS WARRANTY OR IN TORT OR AS A RESULT OF STRICT LIABILITY OR ANY OTHER LIABILITY UNDER OR IN CONNECTION WITH THE EQUIPMENT OR ITS SUPPLY SHALL BE LIMITED TO THE AMOUNT OF THE PURCHASE PRICE OF THE EQUIPMENT. THE REMEDIES STATED IN THIS WARRANTY ARE THE CUSTOMER'S EXCLUSIVE REMEDIES AGAINST WIRELESS BYPASS REGARDING THE EQUIPMENT.
- 6.3 EVEN IF WIRELESS BYPASS HAS BEEN ADVISED SHALL NOT BE LIABLE FOR ANY INDIRECT, INCIDENTAL, SPECIAL OR CONSEQUENTIAL DAMAGES, INCLUDING THE COST OF LABOR BY THE CUSTOMER'S OWN EMPLOYEES, AGENTS OR CONTRACTORS IN IDENTIFYING, REMOVING OR REPLACING THE DEFECTIVE ITEM; LOST PROFITS, AND REVENUES; CUSTOMER WIRELINE ACCESS COSTS; FAILURE TO REALIZE EXPECTED SAVINGS; ANY CLAIM AGAINST A CUSTOMER BY A THIRD PARTY; OR ANY OTHER COMMERCIAL OR ECONOMIC LOSSES OF ANY KIND.

DEFINITIONS

- 1.1 In these Conditions, unless there is something in the subject matter or context necessarily inconsistent:
 - (a) "Wireless Bypass " means Wireless Bypass Incorporated (d.b.a. Wireless Bypass), Salem, NH;
 - (b) "Equipment" means the equipment itemized on the Quotation/Order Acknowledgment;

PRELIMINARY

- (c) "International" means any location other than United States of America and Canada, including their territories and possessions;
 - (d) "North America" means any location in the United States of America and Canada, including their territories and possessions;
 - (e) "Order Acknowledgment" means the sales order acknowledgment provided by Wireless Bypass to the Customer; (f) "Payment Instructions" means Wireless Bypass 's payment instructions;
 - (g) "Quotation" means the quotation signed by an authorized representative of Wireless Bypass and provided to the Customer;
 - (h) "Shipping Date" means the actual date on which the Equipment left Wireless Bypass's factory at Salem, NH, U.S.A.;
 - (i) "Warranty" means Wireless Bypass 's warranty, document W97-1;
 - (j) "Invoice" means the bill of goods prepared by Wireless Bypass for the equipment with the shipping and any insurance costs.
- 1.2.1 Headings have been inserted in these Conditions for convenience of reference only and will not effect their construction.

ENTIRE AGREEMENT

- 2.1 The Quotation, these Conditions of Sale, the Order Acknowledgment, the Payment Instructions and the Warranty shall apply to all sales made by Wireless Bypass and shall constitute the entire agreement by Wireless Bypass and the Customer (the "Agreement).
- 2.2 Any terms and/or conditions of sale, which may be included on the Customer's purchase order form or any communication from the Customer, that are not identical with the terms and conditions stated in this document shall NOT become a part of the agreement of sale unless expressly agreed to in writing in the Quotation.
- 2.3 Wireless Bypass 's failure to object to any terms and/or conditions of sale contained in any communication from the Customer shall not be considered as acceptance of such terms and/or conditions or as a waiver of the terms and conditions of sale contained herein.
- 2.4 Wireless Bypass shall sell to the Customer, and the Customer shall purchase from Wireless Bypass , the Equipment in accordance with the Agreement. Wireless Bypass accepts the Customer's purchase orders for Equipment and agrees to deliver the Equipment to the Customer only on the terms of the Agreement.
- 2.5 No variation of the Agreement shall be binding unless agreed to in writing by authorized representatives of Wireless Bypass and the Customer.

PRICING

- 3.1 All prices in the Quotation are exclusive of all shipping charges and all applicable taxes including but not limited to, federal, state, local, excise, sales and use taxes.
- 3.2 All prices in the Quotation unless otherwise stated: (a) for North American customers are FOB Salem, NH, USA. (New York Uniform Commercial Code); or (b) for international customers are Ex-Works, Salem, NH, U.S.A. (Incoterms 1990).
- 3.3 All prices in the Quotation include standard domestic packing, unless a separate line item is provided detailing export or special packing charges.
- 3.4 All prices in the Quotation unless otherwise stated are in USD:

SHIPPING AND INSURANCE

- 4.1 Wireless Bypass shall arrange shipping and insurance when requested by the Customer, and shall bill the Customer for the Equipment with the shipping and any insurance costs as separate items, on an invoice (the "Invoice").
- 4.2 Delivery dates quoted by Wireless Bypass are to be considered estimates only. In no event will Wireless Bypass be liable for any loss or damage resulting from its failure to deliver products within a specified time.

PRELIMINARY

TERMS OF PAYMENT

- 5.1 The Customer shall pay for all Equipment, including shipping and insurance in accordance with the terms of the Invoice.
- 5.2 All Invoices for North American Customers are due and payable in thirty (30) days from the date of the Invoice.
- 5.3 International Customers shall make payments in accordance with Wireless Bypass 's Payment Instructions by either:
 - (a) providing a wire transfer (telegraphic transfer) for the full amount of the Equipment, shipping and insurance charges contained in the Quotation or the pro-forma Invoice sent to the Customer, prior to the Shipping Date; or
 - (b) establishing an acceptable Letter of Credit (LC) for the full amount of the Equipment, shipping and insurance charges contained in the Quotation prior to the order being booked and accepted by Wireless Bypass.
- 5.4 if a Customer fails to pay an Invoice when due, Wireless Bypass may, without prejudice to any other remedy, postpone shipments, alter payment terms, terminate the Agreement and charge interest on all overdue amounts the rate of 1.5% per month compounded monthly (or if less, the maximum allowed by law). Upon demand, the Customer shall pay all such interest charges and all reasonable collection fees, including reasonable legal expenses.

SECURITY FOR PAYMENT

- 6.1 If the Customer is located in North America, the Customer grants to Wireless Bypass a purchase money security interest in the Equipment to secure the payment of the purchase price of the Equipment and all other amounts due from the Customer.
- 6.2 If the Customer is not located in North America:
 - (a) despite delivery and passing of risk in the Equipment and any other provision of these Conditions, the title in the Equipment shall not pass to the Customer until Wireless Bypass has received payment in full of the purchase price of the Equipment and all other amounts then due from the Customer, and
 - (b) until the title in the Equipment passes to the Customer:
 - (i) the Customer shall hold the equipment as Wireless Bypass's fiduciary agent and bailee, and shall properly store, protect and insure the Equipment and shall identify the Equipment as Wireless Bypass property;
 - (ii) if the Customer fails to pay Wireless Bypass in accordance with the agreed payment terms, Wireless Bypass may require the Customer to deliver up the Equipment to Wireless Bypass, and, if the Customer does not, Wireless Bypass may enter on the premises where the Equipment is stored and repossess the Equipment; and
 - (iii) the Customer shall not pledge the Equipment by way of security for any, indebtedness of the Customer, but if the Customer does so all moneys owed by the Customer to Wireless Bypass shall, without prejudice to any other remedy of Wireless Bypass, immediately become due.

CHANGES TO PRODUCT SPECIFICATIONS

- 7.1 Wireless Bypass may, without notice to the Customer, make changes to the specifications of Equipment which do not materially affect the quality or performance of the Equipment.

EQUIPMENT CONFIGURATION AND EXPEDITING CHARGES

- 8.1 At the Customer's request, Wireless Bypass may, for a fee agreed in advance:
 - (a) reconfigure the Equipment; or
 - (b) expedite the Customer's order.

PRELIMINARY

CONDITIONS OF SALE SHORTAGES

- 9.1 The customer shall not make any claim for shortages (which are items that the Invoice does not show are on back-order) after twenty-one (21) days after the date of the Invoice.

RETURNS AND EXCHANGES

- 10.1 The return of defective Equipment is covered by the Warranty.
- 10.2 The Customer may only return Equipment that is not defective if:
- (a) the Equipment does not correspond with the Customer's purchase order; or
 - (b) the Equipment has been ordered in error by the Customer and Wireless Bypass has permitted the Customer to remedy the mistake by ordering the correct equipment and resuming the Equipment and the Customer obtains a Returned Materials Authorization number ("RMA #") from Wireless Bypass prior to returning any Equipment.
- 10.3 Wireless Bypass reserves the right to charge a fee for returned equipment under Subparagraph 10.2(b) with the amount of the fee being determined prior to an RMA # being given by Wireless Bypass. 10.4 Authorized returns of equipment under Paragraph 10.2 must be in an undamaged condition, in the original configuration, in the original packing materials and within a time period agreed to when the RMA # was issued.
- 10.5 If the Customer does not comply with the provisions of Paragraphs 10.2, 10.3, and 10.4, the Customer shall pay the full amount of the Invoice.
- 10.6 The party liable for all shipping, insurance and any other expenses incurred by the Customer in returning the Equipment under Paragraph 10.2 and for all loss or damage to the Equipment until received by Wireless Bypass, shall be: (a) for all items returned under Subparagraph 10.2(a), Wireless Bypass and (b) for all items resumed under Subparagraph 10.2(b), the Customer.

CANCELLATION

- 11.1 If the Customer cancels an order before the Shipping Date, Wireless Bypass reserves the right to charge the Customer a cancellation charge up to 100% of the amount of the order.
- 11.2 The Customer shall pay all cancellation charges within thirty (30) days from date of the Invoice.

FORCE MAJEURE

- 12.1.1 Wireless Bypass shall not be liable if its performance of the Agreement becomes commercially impractical due to any contingency beyond Wireless Bypass's reasonable control, including acts of God, fires, floods, wars, sabotage, civil unrest, accidents, labor disputes or shortages, government laws, rules and regulations, whether valid or invalid, inability to obtain material, equipment or transportation, incorrect, delayed or incomplete specifications, drawings or data supplied by the Customer or others (collectively "Force Majeure").
- 12.1.2 In no event of Force Majeure shall Wireless Bypass be required to purchase goods from others to enable it to deliver the Equipment under the Agreement.

ENGINEERING AND SYSTEM DESIGN

- 13.1 The Customer is solely responsible for the engineering, design, integration and normal preventative and remedial maintenance of the Customer's system for which Wireless Bypass supplies Equipment.
- 13.2 Wireless Bypass is not responsible for the satisfactory operation of the Equipment in conjunction with other manufacturer's equipment, nor for any losses that may occur as a result of a failure of the Equipment to operate in conjunction with other manufacturer's equipment.

WARRANTY

- 14.1 All Equipment is covered by the Warranty.

PRELIMINARY

- 14.2 THE WARRANTY CONTAINS LIMITATIONS ON THE CUSTOMER'S RIGHTS AND REMEDIES AGAINST WIRELESS BYPASS UNDER THE AGREEMENT. THE CUSTOMER ACKNOWLEDGES HAVING READ, UNDERSTOOD AND AGREED TO THOSE LIMITATIONS.

DAMAGES FOR BREACH OF AGREEMENT

- 15.1 If either party is successful in any litigation between the parties based on the Agreement, the successful party shall recover from the other, in addition to direct damages, the successful party's reasonable attorney's fees and other costs of litigation.

INSOLVENCY OF CUSTOMER, ETC.

- 16.1 Wireless Bypass may cancel the Agreement and suspend any further deliveries under the Agreement without any liability to the Customer, and, if Equipment has been delivered but not paid for, the price shall become immediately due and payable despite any other agreement to the contrary if:
- (a) any proceedings in bankruptcy, insolvency, receivership or liquidation are taken against the Customer;
 - (b) the Customer makes an assignment for the benefit of creditors or commits an act of bankruptcy or insolvency;
 - (c) the Customer ceases, or threatens to cease, to carry on the ordinary course of its business, or transfers all or substantially all of its property;
 - (d) the Equipment is seized under any legal process or confiscated; or
 - (e) Wireless Bypass in good faith believes that the ability of the Customer to pay or perform any provision of the Agreement is impaired, or that any of the events mentioned above is about to occur.

NOTICE

- 17.1 All requests, instructions and notices from one party to the other must be in writing and may be given via registered post or facsimile transmission to the address of the parties shown on the Quotation or Order Acknowledgment.

EXPORT PROVISIONS

- 18.1 The Customer shall not, whether directly or indirectly (including facilitating a third party) export or re-export the Equipment outside the country in which the Customer has stated these items are to be used without obtaining the licenses required under all applicable rules. The Customer shall indemnify Wireless Bypass against any liability incurred by Wireless Bypass due to any violation by the Customer of any of the provisions of this Section, but this indemnity shall not apply if the Customer reasonably relies on information supplied to it by Wireless Bypass with respect to export licenses. Upon receipt of a governmental consent to export the receiving party shall immediately notify the other in writing.

MISCELLANEOUS

- 19.1 No waiver by Wireless Bypass of any breach of this Agreement shall be considered as a waiver of any subsequent breach of the same or any other provision.
- 19.2 Any provision of the Agreement which is, or is deemed to be, unenforceable in any jurisdiction shall be severable from the Agreement in that jurisdiction without in any way invalidating the remaining portions of the Agreement, and that unenforceability shall not make that provision unenforceable in any other jurisdiction.
- 19.3 The rights which accrue to Wireless Bypass by virtue of the Agreement shall inure for the benefit of and be binding upon the successors and assigns of Wireless Bypass .
- 19.4 The agreement shall be governed by the laws of the State of New Hampshire including the New Hampshire Uniform Commercial Code. However Wireless Bypass may enforce the provisions of the Agreement in accordance with the laws of the jurisdiction in which the Equipment is situated. The United Nations Convention on the Sale of Goods (The Vienna Convention) shall not apply to the Agreement.
- 19.5 Les parties ont exigés que cette entente soit rédigée en anglais.

PRELIMINARY

PRELIMINARY