



Wireless Matrix MBS2-LP Installation Guide

MBS2-LP Installation Guide

Copyright © 2005 Wireless Matrix Corporation. All rights reserved.

Printed in the United States of America

This document is proprietary to Wireless Matrix Corporation. Do not reproduce, use or disclose without permission.

We have made every effort to ensure the accuracy of all information contained in this document. However, Wireless Matrix Corporation makes no expressed or implied warranty or representation based upon the enclosed information.

Revision History:

Version 1.0

9/30/05

Initial Version

Wireless Matrix MBS2-LP Installation Guide

TABLE OF CONTENTS

REGULATORY STATEMENTS	IV
OTHER SAFETY PRECAUTIONS	V
INTRODUCTION.....	1
TECHNICAL SUPPORT.....	1
USER INFORMATION	1
PRE-INSTALLATION CONSIDERATIONS	1
GENERAL CONSIDERATIONS.....	2
PERFORMANCE CONSIDERATIONS	2
SPECIAL MOUNTING RECOMMENDATIONS	2
INSTALLATION OVERVIEW	3
INSTALLATION	3
SYSTEM CONNECTIONS	3
INSTALLATION INSTRUCTIONS	4
ANTENNA INSTALLATION.....	4
WIRELESS MATRIX MBS2-LP INSTALLATION PROCEDURES	5
WIRELESS MATRIX MBS2-LP SYSTEM VERIFICATION LIST	9
POTENTIAL PROBLEMS	10
WARRANTY.....	11
RETURN POLICY	12
APPENDIX - WIRELESS MATRIX MBS2-LP COMPONENT LIST	15

Regulatory Statements

Read and understand the entire manual and follow the safety instructions.

The following regulatory approvals apply for the Mobile Base Station 2 Low Profile (MBS2-LP):

- FCC
- IC
- PTCRB

FCC Part 15 Compliance

This device complies with Part 15 of the FCC Rules. Operation is subject to the following two conditions:

1. This device may not cause harmful interference
2. This device must accept any interference received, including interference that may cause undesired operation.

Modifications not expressly approved by Wireless Matrix USA, Inc. could void the user's authority to operate the equipment.

NOTE: This equipment has been tested and found to comply with the limits for a Class B digital device, pursuant to Part 15 of the FCC Rules. These limits are designed to provide reasonable protection against harmful interference in a residential installation. This equipment generates, uses and can radiate radio frequency energy and, if not installed and used in accordance with the instructions, may cause harmful interference to radio communications. However, there is no guarantee that interference will not occur in a particular installation. If this equipment does cause harmful interference to radio or television reception, which can be determined by turning the equipment off and on, the user is encouraged to try to correct the interference by one or more of the following measures:

- Reorient or relocate the receiving antenna.
- Increase the separation between the equipment and receiver.
- Connect the equipment into an outlet on a circuit different from that to which the receiver is connected.
- Consult the dealer or an experienced radio/TV technician for help.

The MBS2-LP satellite radio emits radio frequency (RF) energy when transmitting. The MBS2-LP must be installed in a manner that provides a minimum separation distance of 20 cm or more between the antenna and persons to satisfy FCC RF exposure requirements for mobile transmitting devices.

Operators should maintain a safe distance from radio when transmitting. Wireless Matrix recommends installing the MBS2-LP device with a safe distance of 63 cm or more. The safe distance of 63 cm is measured from the center of the antenna beam with respect to the FCC OET Bulletin 65, Edition 97 01 "Evaluating Compliance With FCC Guidelines for human Exposure to Radiofrequency Electromagnetic Fields". The 63 cm distance should be maintained under the following conditions:

- The antenna is powered on and transmitting. The MBS2-LP transmits only when the computer in the vehicle sends messages to the host computer.
- A person is blocking line-of-sight to the satellite during transmission. A person on or above the vehicle roof and within 63 cm of the unit could interfere with the MBS2-LP transmission path.

Other Safety Precautions

Read and understand the complete Installation Guide, including the Safety Precautions, prior to using the MBS2-LP Modem.

The MBS2-LP is a radio unit used to receive and transmit data. When in operation, the MBS2-LP transmits and receives RF signals to and from a Geo-stationary orbital satellite.

The MBS2-LP must be used in accordance with the safety guidelines stated in this document. Failure to comply could result in physical harm and can be a hazard to the health of the operator of this unit.



The following safety precautions must be observed during all phases of the operation, usage, service or repair of the MBS2-LP unit.

1. The MBS2-LP must be operated at the voltages described in the unit technical documentation.
2. The MBS2-LP must not be mechanically or electrically changed or modified. Use of all connectors should follow the guidance of the MBS2-LP technical documentation.
3. Replace fuse with same type and rating for protection against fire and damage.
4. The MBS2-LP is a Radio Frequency (RF) generating device. Do not operate the unit when anyone is in the vicinity noted in the Safety Information section of this guide. This could result in personal injury.
5. Do NOT operate the MBS2-LP unit in areas where explosives are in use as the RF frequency could interfere with the operation, causing hazardous conditions. Do NOT operate the MBS2-LP unit in areas where two-way radio communications is prohibited.
6. Use discretion when determining the MBS2-LP installation point. After installation, ensure that all systems are functioning properly. Consult vehicle dealer for further information.



1. Replace fuse with same type and rating for protection against fire and damage.
2. The Wireless Matrix MBS2-LP is a RF generating device. Do not operate the unit when anyone is in the vicinity noted in the Safety Information section of this guide. This could result in personal injury.
3. Do NOT operate the MBS2-LP unit in areas where explosives are in use as the RF frequency could interfere with the operation, causing hazardous conditions. Do NOT operate the MBS2-LP unit in areas where two-way radio communications is prohibited.
4. Use discretion when determining the MBS2-LP installation point. After installation, ensure that all systems are functioning properly. Consult vehicle dealer for further information.



1. **READ THIS MANUAL IN ITS ENTIRETY!**
2. Keep all original Packing Materials.
3. Use caution when installing screws or drilling through the body of the vehicle to avoid puncturing critical areas.
4. Install included grommets and weather sealant to protect cable integrity and weatherproofing the area of penetration.
5. Follow the instruction enumerated in the Installation Section of this guide to ensure proper hardware installation.
6. Ensure that the MBS2-LP is installed in an area with sufficient overhead clearance where it will NOT collide with any other surfaces and in a location that will NOT affect the RF transmission.

7. Pay close attention to the electrical power installation requirements described in this guide. Failure to comply with the described section could result in serious damage to the electrical system of the vehicle.

MBS2-LP Installation Guide

INTRODUCTION

This guide explains procedures for installing the Wireless Matrix Mobile Base Station 2 – Low Profile (MBS2-LP) modem. The guide does not provide detailed installation instructions for every type of vehicle. Instead, because of the variety of available vehicle makes and models, it outlines the installation process and allows the installer to choose appropriate options.

Though the installation process is straight forward, it is important to plan your installation carefully. By planning your installation, you can avoid potential problems and determine the best approach to installing the Wireless Matrix MBS2-LP. Be aware that changes to a component's position or mounting method may be necessary because of vehicle differences that we could not anticipate when writing this guide. Try to predict installation variations by reviewing the Installation Instructions section of this guide before installing the Wireless Matrix MBS2-LP hardware.

This guide is broken into three different sets of installation instructions, covering the steps for installation on the basis of the communications configuration of the MBS2-LP unit. As there are divergent steps in wiring and other installation elements associated with each of the configurations, each section will be all-inclusive for the installation of the configuration identified.

TECHNICAL SUPPORT

Technical support is provided through your service provider. They will provide information and answers to questions about the hardware and software described in this guide. Please reference your Problem Escalation Guide for your technical support listing.

USER INFORMATION

The Wireless Matrix MBS2-LP is a combination of communication hardware that, when connected to the Client Side Computer (CSC), provides the most sophisticated communication functionality currently available. The Wireless Matrix MBS2-LP consists of an antenna and a power-data cable. Before shipping, Wireless Matrix will configure and commission the Wireless Matrix MBS2-LP on its Mobile Data Services network for your account.

PRE-INSTALLATION CONSIDERATIONS

You should perform a pre-installation evaluation before installing any Wireless Matrix MBS2-LP components. A pre-installation evaluation will provide information about how and where to install the Wireless Matrix MBS2-LP and will help identify potential installation problems. During the pre-installation evaluation, you should estimate available space for component placement, cable routing and inspect the vehicle's roof to determine its suitability for an antenna installation. After completing a pre-installation evaluation, you should know where to locate components, how to route cabling and what antenna shelf or antenna bracket type to use for the particular installation.

Contact your vehicle dealer for information about obtaining an Original Equipment Manufacturer (OEM) antenna shelf or bracket. Wireless Matrix antenna brackets are also available.

General Considerations

- Check for wires or obstructions at the opposite side of any panel in which you intend to drill.
- Stay at least 20 inches away from an operating antenna when you are above the level of the antenna base.
- Do not remove the antenna cover. Removing the antenna cover will void the product warranty.
- Do not paint the antenna. Paint on the antenna will void the product warranty. Paint may also interfere with signal transmission or reception.
- Avoid stretching or pinching the power-data cable when tilting the cab of a cab-over vehicle.

Performance Considerations

- The antenna mount must support the antenna weight and wind force created by vehicle motion.
- An “unobstructed line of sight” from the antenna to the satellite is essential for reliable communications.
- Avoid tight bends and kinks in the power-data cable; the tightest allowable bend radius is 2-inches.
- Avoid installing equipment in places that may obstruct the driver’s view or restrict access to vehicle controls.
- Metal air dams, metallic paint or air dams made out of fiberglass with embedded metal may cause antenna interference and will limit antenna placement options.

Special Mounting Recommendations

- Mount the antenna as far forward as possible and center it between the sides of the vehicle. If centering the antenna (side to side) is not possible, move it toward the driver’s side to minimize potential damage by contact with limbs from roadside trees.
- Ensure that the top of the antenna is no higher than the legal 13 1/2-foot limit.
- Secure the power-data cable with cable clamps every 12 to 18-inches and keep it at least 12-inches from the nearest exhaust stack.
- Ensure that cables will not rub against sharp objects or edges.
- Avoid attaching Wireless Matrix MBS2-LP components to parts that could pull, strain, or otherwise cause damage.
- Avoid positioning Wireless Matrix MBS2-LP components such that accidental damage may occur during entry or exit of the vehicle.

INSTALLATION OVERVIEW

Installation

Installing the Wireless Matrix MBS2-LP is not difficult, but you must consider the variables involved, such as, the truck type and location of existing equipment. Installation time can vary depending upon the installer's experience and the vehicle design. While a single individual can perform most installation operations, certain procedures may require the help of a second person. Wireless Matrix offers an installation training program, or can recommend installation vendors in your area who can perform the installation.

Some of the following procedures may require a choice between several hardware options. Some options are not suitable for some installations, so Wireless Matrix recommends that you verify vehicle integrity with the vehicle OEM to ensure that the vehicle structure can support the Wireless Matrix MBS2-LP components. Also, verify that you have the parts and tools necessary to complete the installation.

To install the Wireless Matrix MBS2-LP, follow these steps:

1. Select location for mounting the antenna. Assess cable routes while considering antenna placement.
2. Determine the type of bracket to use, and contact the vehicle OEM for bracket availability.
3. Determine if the proper Wireless Matrix MBS2-LP installation requires temporary removal of vehicle components.
4. Install the shelf or bracket.
5. Install the antenna.
6. Install the power-data cable.
7. Secure all cables to rigid mounts with cable restraints.
8. Verify operation of the Wireless Matrix MBS2-LP.

SYSTEM CONNECTIONS

The Wireless Matrix MBS2-LP connects to the CSC in a variety of ways, depending on configuration. It can connect by either a DB9 straight through power extension cable or directly to the DB9 connector on the supplied power-data cable. It can also connect via 802.11b protocol, or via Ethernet connection.

INSTALLATION INSTRUCTIONS

The following instructions explain the processes for installing the antenna, power-data cable and the power extension cable. The installation process may vary slightly if the vehicle's design or accessories will not permit the execution of the steps outlined below.

Antenna Installation

Ensure there is not a height obstruction. Mount the antenna so that it is level. The highest point of any peripheral metal object must fall below an ascending 15-degree angle that begins at the horizontal and vertical center of the antenna; see figures 1 and 2. Wireless Matrix recommends placing other antennas, e.g., CB or cellular, at least 3-feet from the antenna mount.

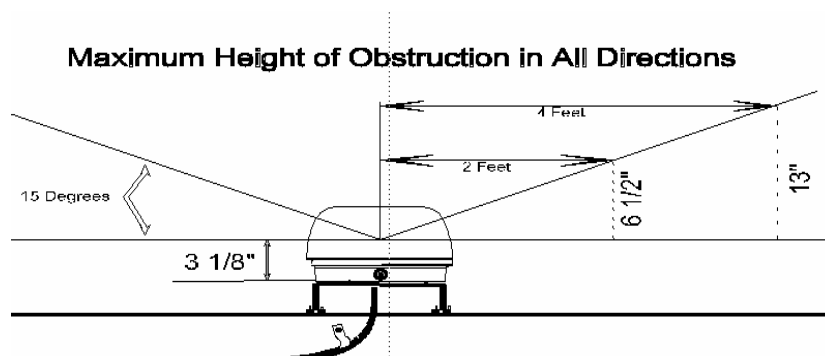

Figure 1. Maximum Obstruction Height

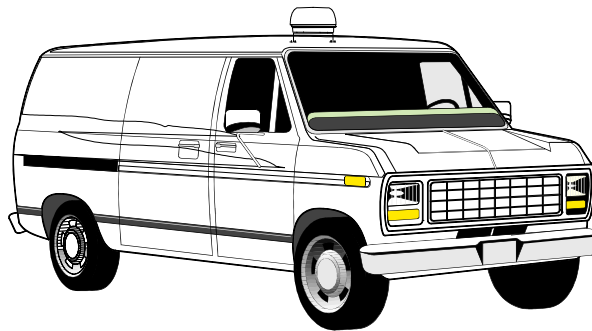
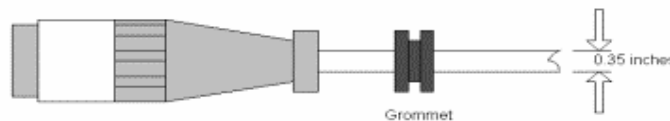

Figure 2. Typical Antenna Mount Location

Wireless Matrix MBS2-LP Installation Procedures

The average time for the Wireless Matrix MBS2-LP installation is about an hour.

1. The Wireless Matrix MBS2-LP is mounted using 1/4-inch x 20 tpi (threads per inch) bolts screwed into its base. The threaded portion in the base is a maximum of 1/2-inches deep. To prevent damage during installation, care should be taken that the thread engagement of the mounting bolt be 1/2-inch or less.
2. Locate the desired installation location on the vehicle (ideally on an area where the antenna will be exposed from all angles, as described in Antenna Installation section of this guide).
3. Place a piece of duct tape over the area to drill, for the antenna mount bolts and cable access (this will prevent the drill bit from sliding and damaging the roof surface).
4. Place the antenna mount's (refer to the appendix for the Wireless Matrix part number) mounting bracket on the desired location and mark the four drilling points (use bracket as a template for bolt locations).
 - ⇒ **NOTE:**
Avoid drilling through wires, mounted fixtures or equipment. Secure the bracket to vehicle supports or framing.
5. Drill the four 5/16-inch holes for the antenna mount, as marked by the template, and an additional 1/2-inch hole at a selected location for cable access.
6. Install the antenna mount's (refer to the appendix for the Wireless Matrix part number) antenna bracket with its corresponding mounting hardware.
7. Install the Wireless Matrix MBS2-LP to the antenna mount's (refer to the appendix for the Wireless Matrix part number) mounting plate with the three 1/4-inch mounting bolts and washers.
8. Assemble the antenna mount's (refer to the appendix for the Wireless Matrix part number) mounting plate to the mounting bracket and secure with the mounting hardware.
9. Place the 1/2-inch grommet into place (around the cable hole) to protect the cable from damage.
10. The Wireless Matrix MBS2-LP power-data cable is supplied without the DB9 bodies and shells installed. Figure 3 displays the wiring diagram for this cable.



Power-Data Cable

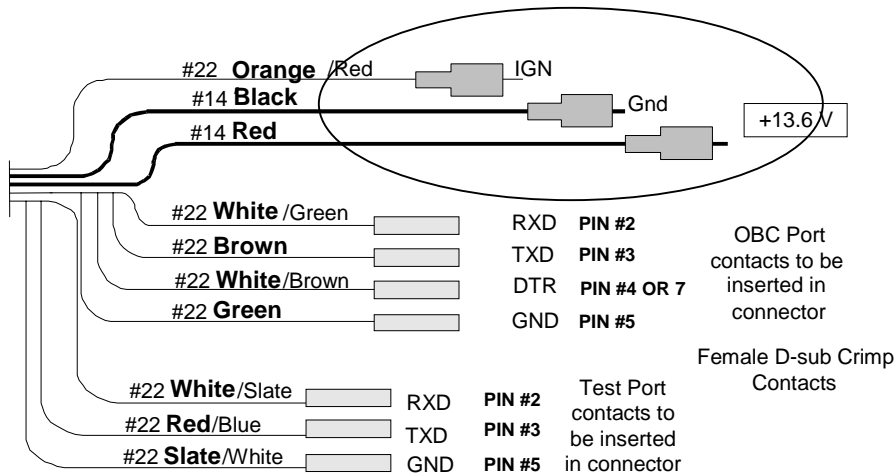

MBS2-LP Power-Data Cable (Detail)

Figure 3. Power-Data Cable Configuration Diagram

11. The shells and bodies are supplied separately and are attached to the cable after the unit cable is in place. This allows the cable to be inserted through a smaller opening in the vehicle chassis. Figure 4 displays the pinout of the factory-assembled connector that connects to the Wireless Matrix MBS2-LP.

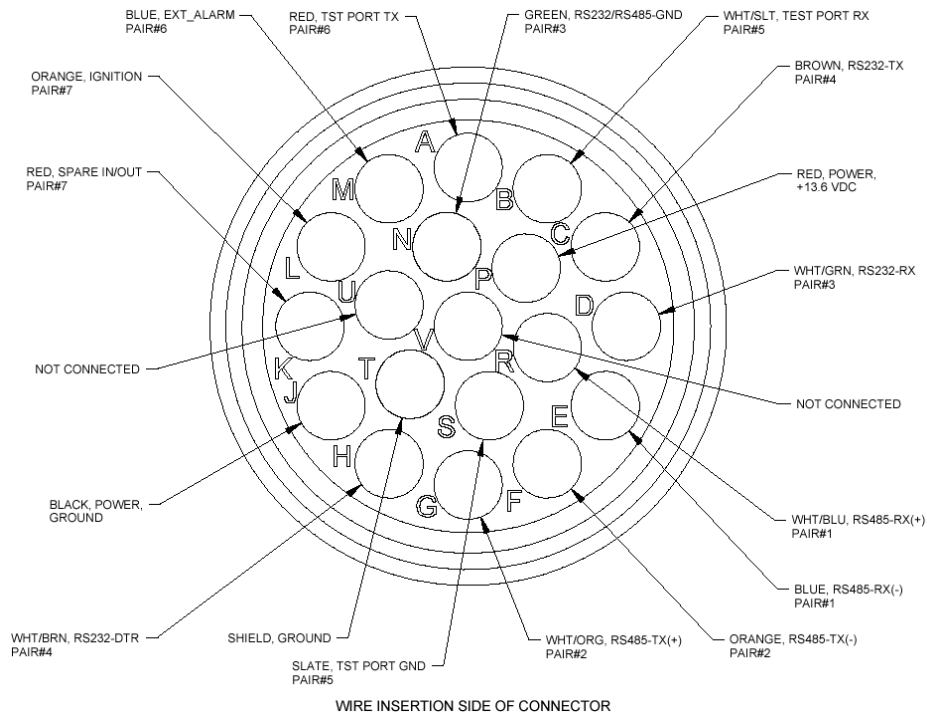

Figure 4. Wireless Matrix MBS2-LP Connector Configuration Diagram

- ⇒ **NOTE:**
The RS-422 transceiver in the MBS2-LP unit is disabled when the MBS2-LP is installed for use in RS-232 mode. As a result, it is acceptable to cut back the unused RS-422 wires if desired.

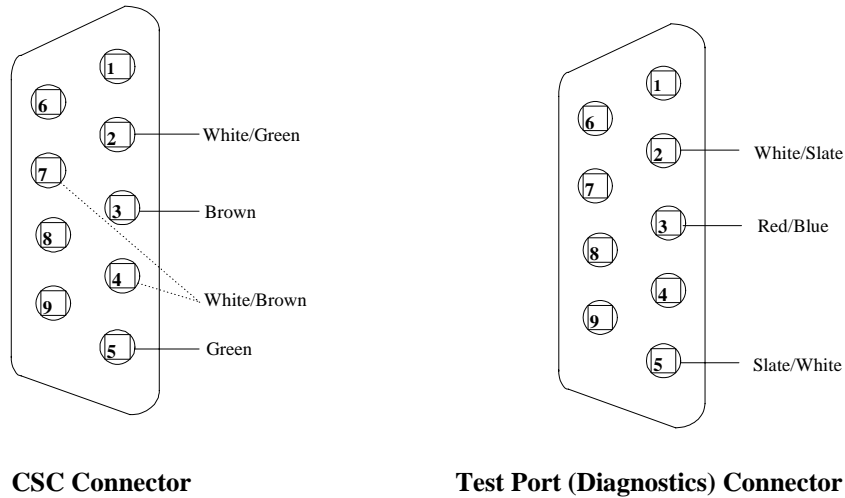

Figure 5. MBS2-LP DB9 Connectors

12. See figure 5 for the pin insertion locations. If the DB9 contacts must be removed for any reason, use Amp tool No. 91285-1 or equivalent.

- ⇒ **NOTE:**
The DB9 Connector diagram in Figure 5 is looking at the back of the connector. The backside is considered to be the side with the black plastic protruding and the two pair twisted cable is to be inserted from this side. The front of the DB9 Connector only has the metal housing protruding.

- ⇒ **NOTE:**
Some hardware does not support DTR. For this hardware, the white/brown pin should be routed to Pin 7 (RTS).

13. The CSC connector (see figure 5) is the port used by the Wireless Matrix MBS2-LP to communicate with the Client Side Computer (CSC). This port allows the communication between the Wireless Matrix MBS2-LP and the CSC to take place.

The CSC is a DB9 Female connector that uses four leads of the power-data cable (19 pin, cannon connector) with the pin-out configuration as displayed in figure 5.

The Test Port (Diagnostics) connector (see figure 5) is the port used by the Wireless Matrix MBS2-LP to communicate with the On Board Computer (OBC) module located within the CSC for test and diagnostic purposes only. This port allows diagnostics capabilities between the Wireless Matrix MBS2-LP and the user interface, such as HyperTerminal.

The Test Port is a DB9 Female connector that uses three leads of the power-data cable (19 pin, Cannon connector) with the pin-out configuration as displayed in figure 5.

14. Run the antenna power-data cable (the end without connectors) from the top of the roof in to the cabin through the grommet, and route the cable in the inside of the vehicle as desired to reach the constant 12-volt power source.
15. Connect the power-data cable to the Wireless Matrix MBS2-LP by matching the connector grooves and twisting the connector to its locked position.
16. Once the desired length of cable is exposed, use an outside clear silicone sealant to seal and weatherproof the opening.
17. Select the point of access from the engine compartment into the cabin and drill (if necessary) a 1/2-inch hole to run the power extension cable into the cabin.
18. From the engine compartment, identify the constant 12-volt power source (a direct lead from the battery's positive connector can be used).
19. Install the fuse lead of the power extension cable (red, 10 to 12 AWG, lead) and connect to the positive battery lead or selected constant 12-volt power source (see figure 6).

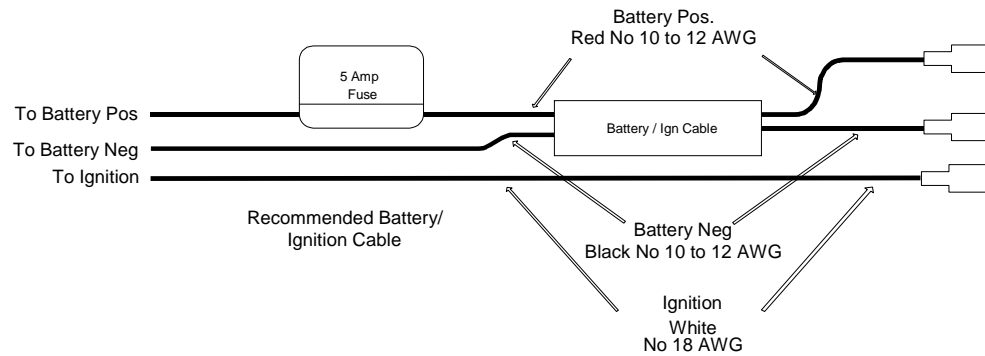

Figure 6. Power Extension Cable Installation Diagram

20. Connect the ignition sensor (white, 18 AWG lead) to its corresponding ignition fused connector at the vehicle's distribution box using a fuse connector.
21. Select a common grounding point and connect the negative, grounding-wire lead (black, 10 to 12 AWG lead) to its ground (the negative battery lead can be used).
22. Connect the positive (red, 12 AWG lead) and the negative (black, 12 AWG lead) of the power extension cable to the corresponding positive and negative leads of the power-data cable.
23. Connect the separate ignition extension cable (white, 18 AWG lead) to the corresponding ignition sensor on the power-data cable (orange/red, 22 AWG lead).
24. Once the power-data cable is installed, assemble the DB9 connectors for the CSC and Test Ports (use the Cable Configuration Diagram, Figure 5).

⇒ **NOTE:**

A DB9 Male to DB9 Female extension cable may be used from the CSC DB9 connector on the power-data cable to reach the 9-pin serial connector on the CSC.

25. Connect the CSC DB9 connector to the 9-pin serial communications port on the CSC.
26. Follow the steps included in the Wireless Matrix MBS2-LP System Verification List section of this guide.

Wireless Matrix MBS2-LP System Verification List

To verify the Wireless Matrix MBS2-LP System is operational; follow this checklist:

1. Move the vehicle to an area where there are no obstructions to the southern exposure for the Wireless Matrix MBS2-LP.
2. Check the cable connections going from the CSC to the Wireless Matrix MBS2-LP and verify they are securely connected.
3. Verify the power source output is 11 to 16 volts.
4. Attempt to send a message to the host or have the host send a message to the vehicle.

Potential Problems

The most common problems with the CSC are power connections and configuration. PLEASE consult your information services department for details in configuring your CSC.

Table 1 lists potential problems with the CSC and suggestions to correct the problems.

Symptom	Suggestions
The CSC does not power up.	a. Check that the power cable is properly connected to the antenna and the power source.
	b. Using the multi meter, verify power is 11-16 volts when the vehicle is on.
	c. Check the power fuse, and ensure it is connected properly.
	d. Check that the vehicle ignition is on and the ignition sensor is connected properly.
	e. Check that the CSC is powered on.
	f. If the problem persists, test the cable for continuity and/or damage.
Power is on, but the CSC application will not connect to the remote host.	a. Check that your CSC is connected to the CSC DB9 connector, NOT THE TEST PORT.
	b. Check that the <i>Wireless Matrix MBS2-LP</i> cable is properly connected.
	c. Contact your service provider and verify the following: <ol style="list-style-type: none"> i. The correct address is configured in the CSC. ii. The address in the CSC corresponds with the X.121 and IP address of the <i>Wireless Matrix MBS2-LP</i> unit. This address is located on a label on the <i>Wireless Matrix MBS2-LP</i>. iii. The <i>Wireless Matrix MBS2-LP</i> unit is commissioned and authorized for use.

Table 1. Symptom and Suggestions for Potential Problems

WARRANTY

Wireless Matrix warrants that upon shipment to Customer from supplier's facility and for the Warranty Period, hereinafter defined, the Equipment shall be free from defective materials and faulty workmanship and capable of accessing the Service ("Good Working Order"). The warranty provided herein shall not apply to (i) hardware normally consumed in operation such as fuses, cables, or mounting brackets, (ii) defects which, due to no fault of Wireless Matrix, are the result of improper use or maintenance of the Equipment, (iii) improper operation of the Equipment used with other equipment, (iv) Equipment which, due to no fault of Wireless Matrix, has been subjected to any kind of detrimental exposure or has been involved in any accident, fire, explosion, Act of God, or any other cause not attributable to Wireless Matrix, (v) any Equipment which has been altered or repaired by any party other than Wireless Matrix without Wireless Matrix's prior consent, (vi) any Equipment sealed against the weather whereby the seal has been broken without Wireless Matrix's prior consent, or (vii) any Equipment hardware or software, including any revisions provided by Wireless Matrix, which has been improperly stored, installed or implemented. Customer shall de-install and return (unless otherwise directed by Wireless Matrix) the failed Equipment to Wireless Matrix. Wireless Matrix shall return the Equipment, or a new or reconditioned unit, at Wireless Matrix's option, free of charge to Customer via best way ground, unless otherwise specified by Customer (with additional costs thereof to Customer's account), during the one year from shipment ("Warranty Period"). Wireless Matrix's warranty obligation is limited to restoring the Equipment to Good Working Order. The repaired or replacement Equipment is warranted for the remainder of the original Warranty Period.

RETURN POLICY

If the troubleshooting process in the Potential Problems section of this guide determines the modem to be defective, return the unit to Wireless Matrix for repair. Contact your service provider and request a Return Material Authorization (RMA) number. To receive an RMA number, be prepared to provide:

1. Customer Address
2. Contact Name and Phone Number
3. Serial Number
4. P.O # (If unit is out of Warranty)
5. Brief description of the problem

Please fill out the RMA form included in this manual and send it in the box with the unit. To speed the handling process, please also mark the RMA number on the shipping label. Please return the unit in its original packing to avoid damage. Ship the unit to:

Wireless Matrix Corporation

c/o Danzas AEI Intercontinental
8-14th Street
Blaine, WA 98230
ATTN: RMA # _____



Returned Materials Authorization (RMA)

RMA #: _____ Date: _____

ALL INFORMATION MUST BE COMPLETE

CUSTOMER:

Customer Name:	_____
Dept/Branch/Unit #:	_____
Ship To Address:	_____

Contact Name:	_____
Contact Phone #:	_____
Contact Fax #:	_____
Contact Email:	_____

FAULTY UNITS TO BE RETURNED:

Select Wireless Matrix Modem Type:	Complete the following applicable fields for your modem type:
<input type="checkbox"/> SDM 1000	Electronic Serial #: _____
<input type="checkbox"/> SDM 1100	X.121 Address: _____
<input type="checkbox"/> SDM 1200	IP Address: _____
<input type="checkbox"/> SDM 1220	Transceiver Unit Serial #: _____
<input type="checkbox"/> SDX 1000	Antenna Unit Serial #: _____
<input type="checkbox"/> SDX 1100	Market Partner ID or Customer Alias #: _____
<input type="checkbox"/> MBS 1000	RTU: _____
<input type="checkbox"/> MBS PRO	
<input type="checkbox"/> MBS 1000-2	

DETAILED PROBLEM DESCRIPTION:

Email RMA Form To: RMA@wrx-us.com

or

Fax RMA Form To: (604) 439-2447

Packing Instructions:

- Pack the unit with at least 2 inches of protective padding on all sides around the unit.
- Place one copy of RMA form inside box
- Place one copy of the RMA form on the outside of the box with the packing slip.

Ship To: Wireless Matrix Corporation
 RMA # _____
 c/o Danzas AEI Intercontinental
 8-14th Street
 Blaine, WA 98230
 ESN # _____

(Form continued on reverse side)

RMA form (continued)

RMA Form

BELOW IS FOR COMPLETION BY WIRELESS MATRIX

Dead on Arrival In Warranty Out of Warranty (please supply Purchase Order)

Replacement Unit(s)

Transceiver Serial #	Antenna Serial #

Date Received	Failure Type (Category & Code)	Date Shipped

Problem Description and Actions Taken (Factory use Only)	Date/Tech Initials

APPENDIX - WIRELESS MATRIX MBS2-LP COMPONENT LIST

Wireless Matrix MBS2-LP Component Name	Part Number
Wireless Matrix MBS2-LP Modem	906-xxx-xxxx or 907-xxx-xxxx
Wireless Matrix MBS2-LP Cable Assembly Kit	800-120-0048
1/2-inch Grommets	
Antenna Mount, Low Profile with 1/4-inch Bolt and Nuts (Optional equipment)	Regular 03-03-037 Adjustable 03-03-071 Low Profile 03-03-075
This Manual	

Required Components

Cordless Drill

Cable Connectors and Butt End Connector

5/16-inch and 1/2-inch Drill Bits

Clear Silicone - Outdoor Sealant

Socket Set

Laptop (CSC)

Recommended Tools & Supplies

RS-232 Pin Tool AMP 91285-1

Wire Stripper

Wire Cutter

Split Loom (Wire Organizer)

DB9/Male to DB9/Female, 4-foot (CSC, DB9 Straight Through
Extension Cable)

Cable Ties (Tie Wraps)

Duct Tape

Multi-Meter (for Power and Continuity Testing)

Crimp Tool