

RFID Smart Reader

with Fan-out Box and RF Switch

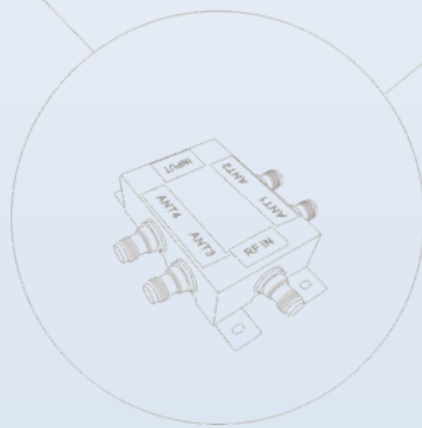
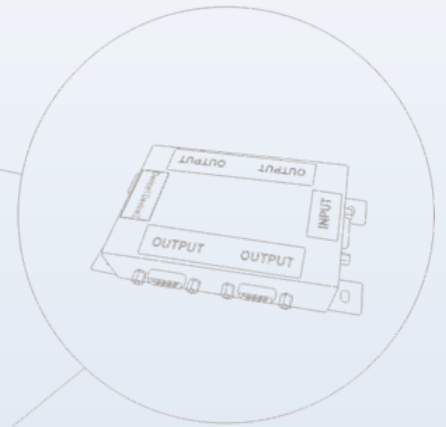

User Manual
English

1. GETTING STARTED	2
1.1 IN THE PACKAGE.....	2
1.2 INTRODUCTION	2
1.3 HARDWARE OVERVIEW- RFID SMART READER	4
1.4 HARDWARE OVERVIEW- FAN-OUT BOX	5
1.5 HARDWARE OVERVIEW - RF SWITCH.....	5
1.6 CONNECTING THE CABLES.....	6
2. CONFIGURATION SOFTWARE.....	9
2.1 ACCESS THE MANAGEMENT INTERFACE	9
2.2 MANAGEMENT	9
3. APPENDIX.....	10
3.1 SPECIFICATIONS: RFID SMART READER	10
3.2 SPECIFICATIONS: FAN-OUT BOX.....	12
3.3 SPECIFICATIONS: RF SWITCH	13
3.4 PIN DEFINITION	14

1. Getting Started

1.1 In the Package

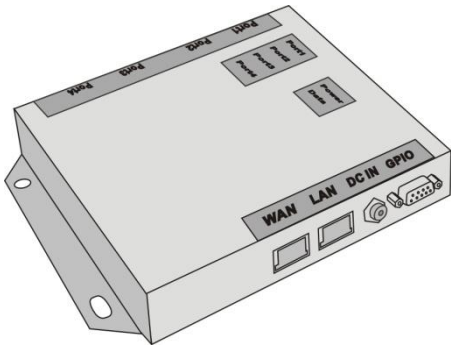

RFID Smart Reader

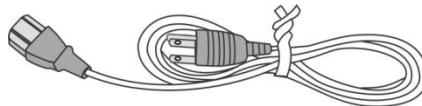

Power Cord

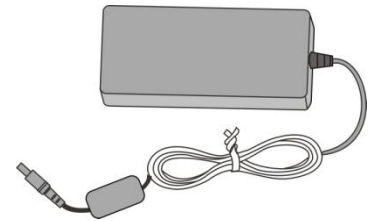

Power Adapter

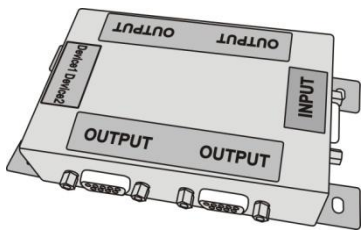

Fan-out Box (optional)

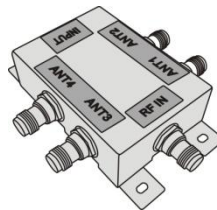

RF Switch (optional)

Note: The Fan-out Box and RF Switch work in combination to allow more antenna connections. One RFID Smart Reader can connect to one Fan-out box and four RF switches.

1.2 Introduction

The WNC RFID Smart Reader (the Reader) is suitable for a variety of UHF RFID applications. It provides high level RF performance, a user-friendly software development interface and a cost competitive reader solution. Combined with a Newave Shelf Antenna, it can provide 100% readability in zone sizes of 2'x2'x2' to 10'x10'x10' with appropriate reader parameters and antenna setup. You can also connect the Reader to a fan-out box and 1~4 RF switches to add additional antennas. A maximum of 16 antennas are allowed for one Reader.

For multi-reader applications, such as retail applications, the Reader solution can efficiently compress data size and solve data traffic issues.

Basic application:

You can connect to up to four antennas and use a computer to monitor detected parameters.

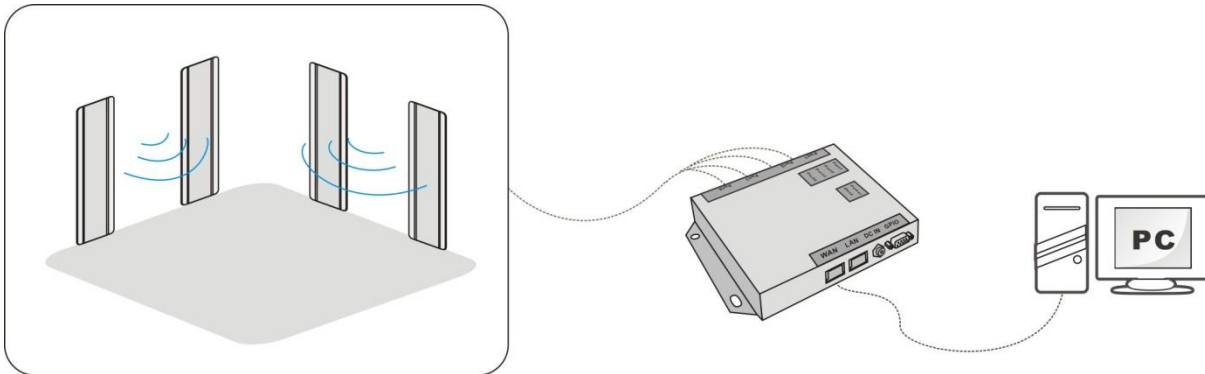

Advanced application:

Use the Reader with a Fan-out Box and an RF Switch to connect up to 16 antennas.

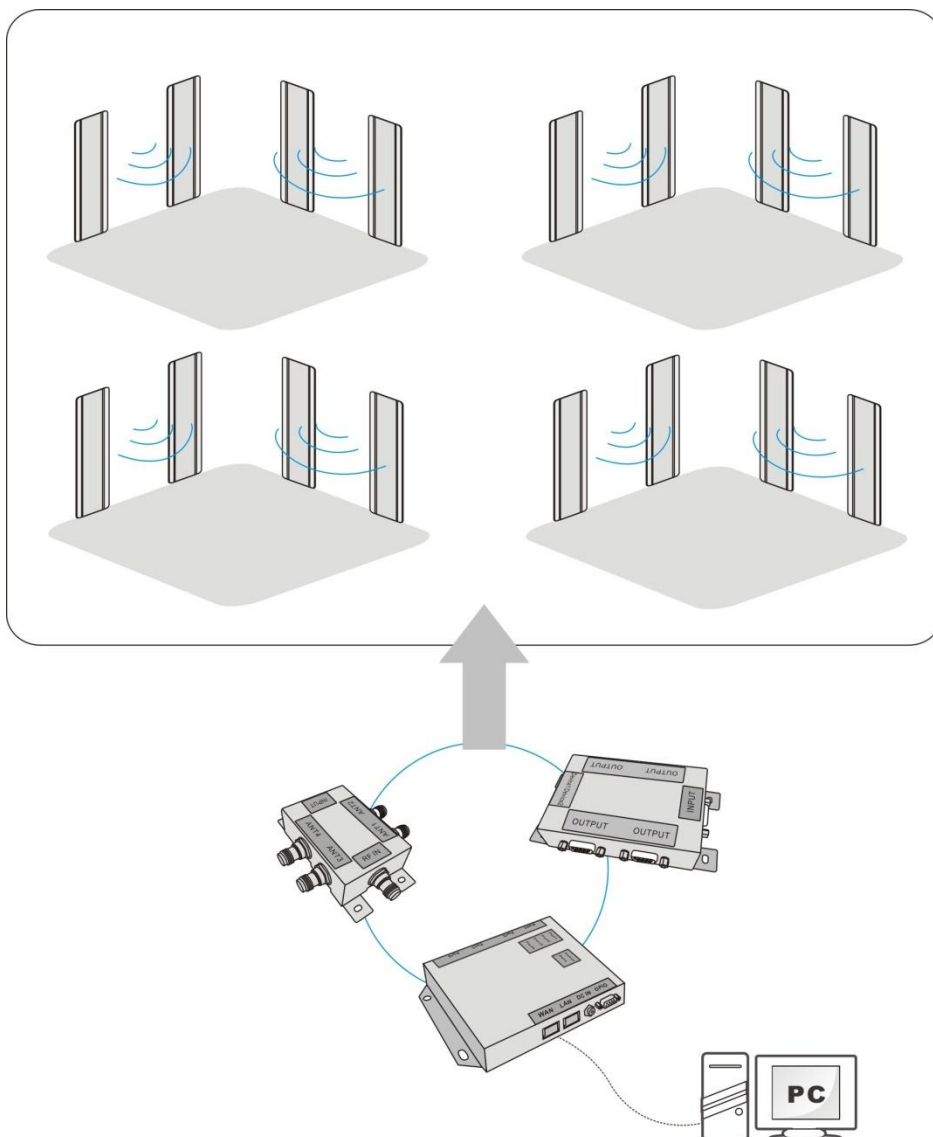

1.3 Hardware Overview- RFID Smart Reader

Front Panel

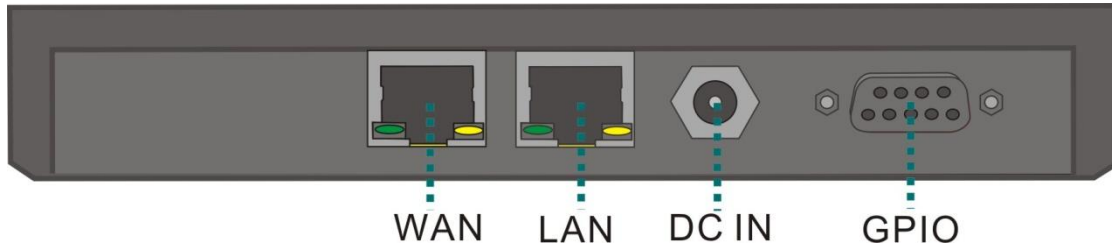

Rear Panel

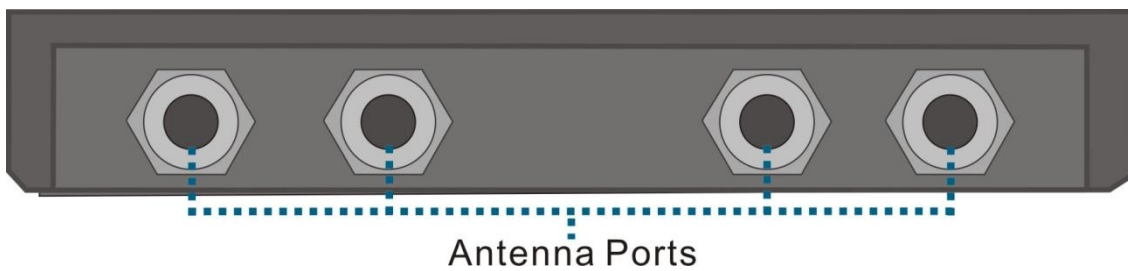

WAN

Connect a standard RJ-45 Ethernet cable to the port to establish a network connection. This feature allows you to configure settings or read the data from the Reader on your computer via a Graphic User Interface. WAN port supports Power over Ethernet (PoE).

LAN

Currently unavailable.

DC IN

Connect the power adapter to the Reader via this inlet to power on the Reader.

GPIO

For GPIO purposes such as connecting a Fan-out Box, light sensor or other sensors.

Antenna Ports

For RF cable insertion. The Reader supports up to four antennas at the same time. Additional connection is also possible via an optional antenna switch.

Note: RJ-45 Ethernet cable and RF cable not included in the package.

1.4 Hardware Overview- Fan-out Box

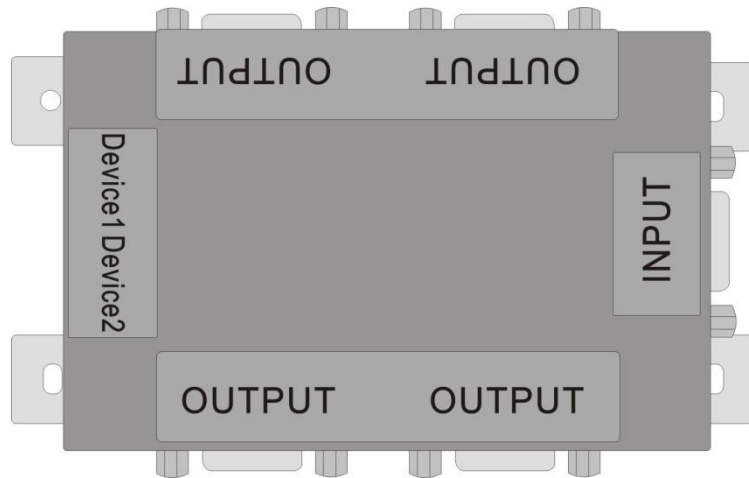

OUTPUT For RF Switch connection.

INPUT Connect to the GPIO port of the Reader.

Device 1 & 2 Sensor data input/output ports for other applications, for example, connecting to entrance and exit sensors for security control.

1.5 Hardware Overview - RF Switch

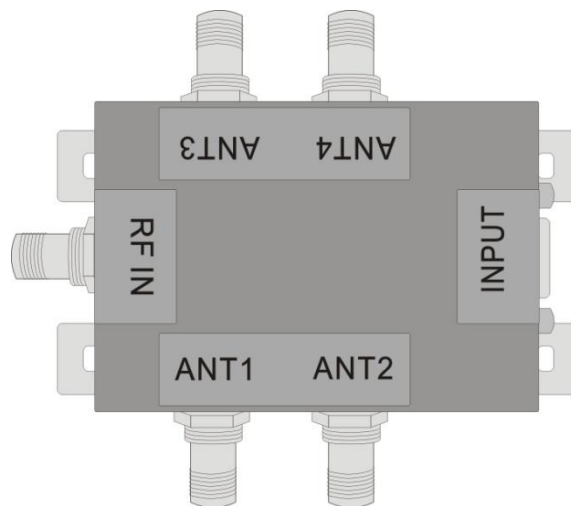

INPUT Connect to an OUTPUT port of the Fan-out Box.

RF IN Connect to an antenna port of the Reader.

ANT 1~4 For antenna connection.

1.6 Connecting the Cables

Basic installation:

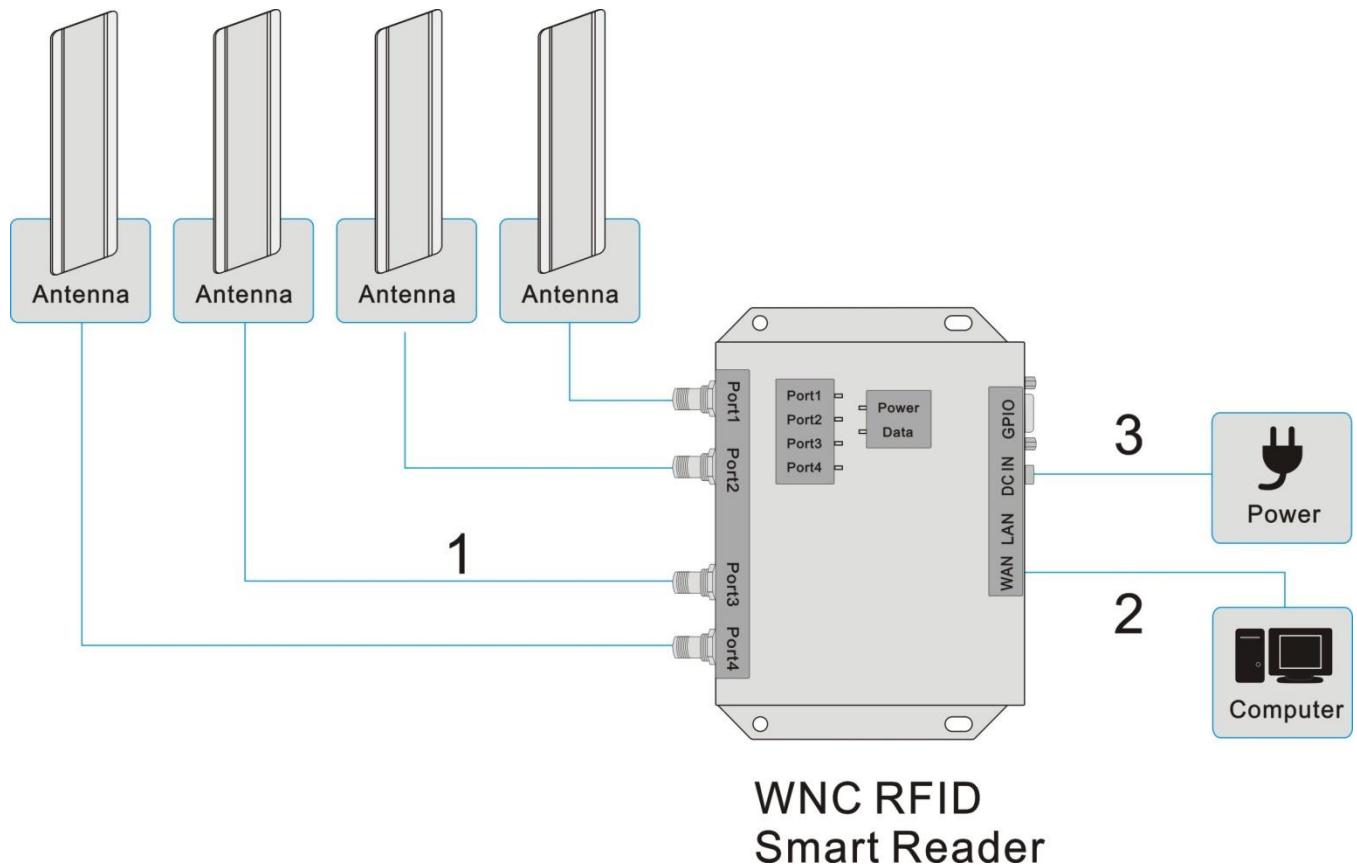

1. Plug an RF cable into an antenna port and an antenna. The Reader supports up to four antennas at the same time.
2. Connect an RJ-45 Ethernet cable to the WAN port and to your computer for software development interface configuration.
3. Connect the power adapter to the DC IN inlet on the Reader. Once the power adapter is connected to the Reader, the Power LED indicator will turn green indicating the power is on.

Note: Reader may be wall-mounted. Insert screws via the four holes on the left and right side of the Reader.

Installation with Fan-out Box and RF Switch:

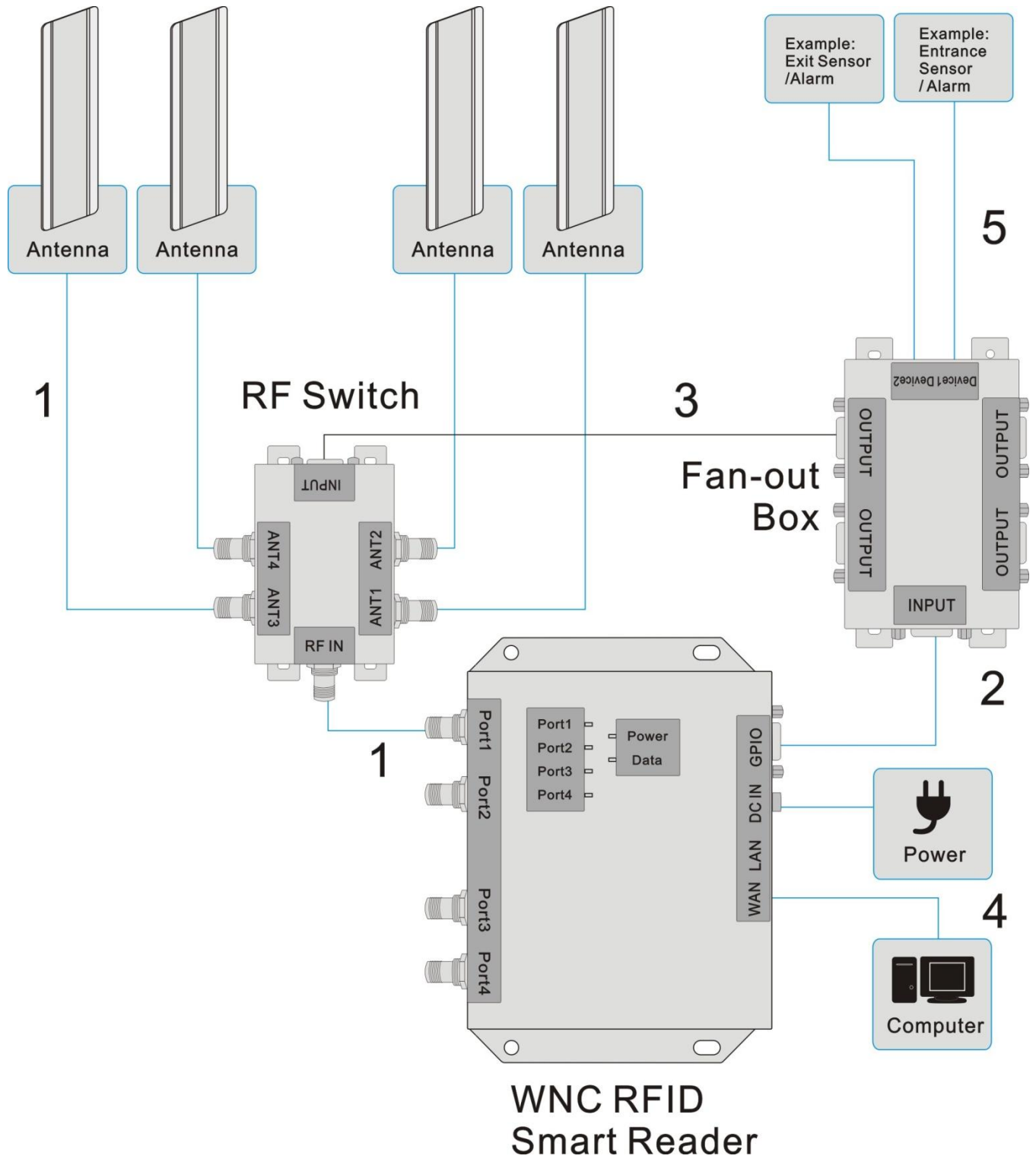

1. Use an RF cable to connect an antenna port of the Reader to the RF IN port of the RF Switch, and then connect the antennas to the ANT1~4 ports of the RF Switch.
2. Use a DB9 cable to connect the GPIO port of the Reader and the INPUT port of the Fan-out box.
Note: Only use a rollover type DB9 cable (not crossover type.) The cable must be shorter than 5m.
3. Use a DB9 cable to connect an OUTPUT port of the Fan-out Box to the INPUT port of the RF Switch.
Note: Only use a rollover type DB9 cable shorter than 30m.
4. Connect the Reader to a computer. Attach the power supply to the Reader and plug it into a wall outlet.
5. You can also connect the Device1 & 2 ports to receive data from other devices such as sensors.

Note: The Reader, Fan-out Box and the RF Switch may be wall-mounted. Insert screws via the four holes on the left and right side of them.

1.5 LED Status (RFID Smart Reader)

LED	Status		
	Green	Red	Off
Power	On: Powered on	On: Power booting	No Power
Data	Blinking: Data transmitting	N/A	No transmission
Port 1 ~ 4	On: Port enabled Blinking: RF inventory	On: Port error Blinking: RF failure	Port disabled

2. Configuration Software

TBD

2.1 Access the Management Interface

2.2 Management

3. Appendix

3.1 Specifications: RFID Smart Reader

RF System	
Chipset	Impinj R2000 ATMEL AT91SAM7S-256
Protocol	
RFID Protocol Support	EPC Global Gen 2 ISO 18000-6C; ISO 18000-6B (optional)
Support EPC DRM	Yes (with DRM Filter) switchable
RF	
Frequency	US: 902 ~ 928MHz EU: 865 ~ 868MHz KR: 910 ~ 914MHz PRC: 920 ~ 925MHz Open: 840MHz ~ 960MHz
Demodulation	ASK or PSK
Modulation Depth	90% nominal
Data Encoding	FM0 or Miller code
Bit Rate	Supports uplink data rates of up to 640 Kbps
TX Output power	28 dBm
Antenna Type	4 port Mono-static
Antenna connector	4 pcs RP TNC
General Characteristics	
Dimensions	18.2 x 13 x 2.6 cm
Weight	~550g
Base Material	Aluminum alloy (AL 5052)
Mounting	Wall, floor
Power Input	1. POE 802.3at 2. DC power input (12 VDC +/-5%, 30W)
Power Consumption	11W

System Architecture	
Processor	TI TMS320DM6446
System Memory / Ram	64MB
Internal Storage / Flash	128MB
Communication	
USB	N/A
Ethernet	10/100 Base-T (RJ-45) X2 (POE x 1 802.3 at compliant)
GPIO	4 input and 2 output (DB9)
Indicators	5 two-color / 1 one-color LED status indicator
Software	
Operation System	Embedded Linux
Software SDK	C#
Environment	
Humidity	5% to 95%, non-condensing
Operating Temperature	- 20°C to 50°C / -4°F to 122°F
Storage Temperature	- 40°C to 85°C / -40°F to 185°F
Sealing / Dust and Water	IP54 (NEMA 3)
Immunity	

3.2 Specifications: Fan-out Box

RF System	
Chipset	MC33202DR2G
Regulatory and Environmental Compliance	
EMC certification	FCC 47 CFG Ch.1 Part 15 (US) (15.247) ETSI EN 302 208-1 (V1.1.1) (EU) (optional)
Certification	RoHS / FCC / CE(optional)
General Characteristics	
Dimensions	12.5 x 6.2 x 2.6 cm
Weight	~250g
Base Material	Aluminum alloy (AL 5052)
Mounting	Wall, floor
Power Consumption	0.5W
Communication	
Input port	1 DB9 female connector
Output port	4 DB9 female connector
External port	2 ACES product:2.0mm WTB WAFER CONN
Environment	
Humidity	5% to 95%, non-condensing
Operating Temperature	- 20°C to 50°C / -4°F to 122°F
Storage Temperature	- 40°C to 85°C / -40°F to 185°F
Sealing / Dust and Water	IP54 (NEMA 3)
Immunity	

3.3 Specifications: RF Switch

RF System	
Chipset	SN74HC139PWR SN74HC240PWR AS221
RF	
Frequency	US: 902 ~ 928MHz/ EU: 865 ~ 868MHz/ KR: 910 ~ 914MHz/ PRC: 920 ~ 925MHz/ Open:840MHz ~ 960MHz/
Typical Insertion Loss	1.2dB
Typical Isolation	36dB
Regulatory and Environmental Compliance	
EMC certification	FCC 47 CFG Ch.1 Part 15 (US) (15.247) ETSI EN 302 208-1 (V1.1.1) (EU) (optional)
Certification	RoHS / FCC / CE(optional)
General Characteristics	
Dimensions	11.4X5.8X2.6 cm
Weight	~350g
Base Material	Aluminum alloy (AL 5052)
Mounting	Wall, floor
Communication	
Input port	1 DB9 female connector
R-TNC	4 R-TNC Connector
Environment	
Humidity	5% to 95%, non-condensing
Operating Temperature	- 20°C to 50°C / -4°F to 122°F
Storage Temperature	- 40°C to 85°C / -40°F to 185°F
Sealing / Dust and Water Immunity	IP54 (NEMA 3)

3.4 Pin Definition

GPIO port of RFID Smart Reader

DB9 Female connector	
Pin1	5V
Pin2	Output port1, 3.2V
Pin3	Output port3, 3.2V
Pin4	Input port1, 3.2V
Pin5	Ground
Pin6	Ground
Pin7	Output port2, 3.2V
Pin8	Output port4, 3.2V
Pin9	Input port2, 3.2V

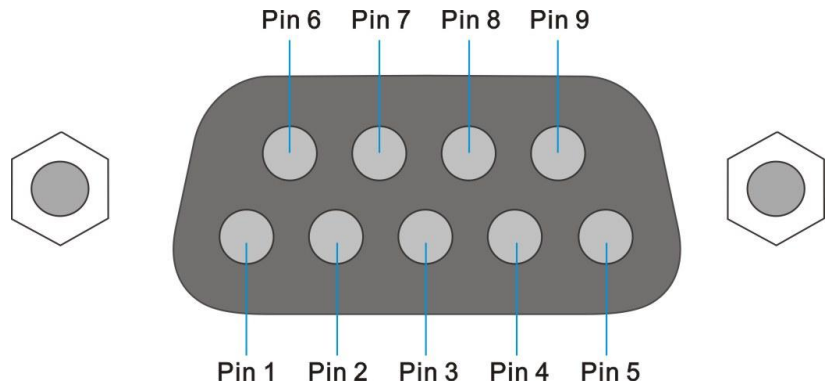

Output ports of Fan-out Box

Output Port	
Pin1	5V
Pin2	GPO_1-
Pin3	NC
Pin4	GPO_2+
Pin5	Ground
Pin6	Ground
Pin7	GPO_1+
Pin8	GPO_2-
Pin9	NC

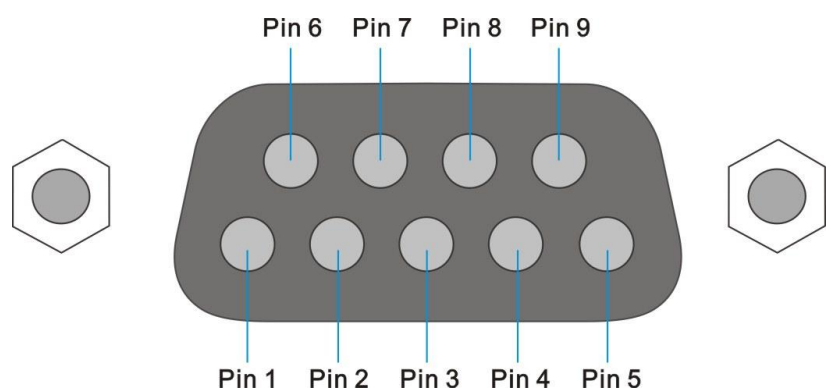

Device 1&2 ports of Fan-out Box

Device 1	
Pin1	5V
Pin2	GPI_1
Pin3	GPO_3
Pin4	Ground

Device 2	
Pin1	5V
Pin2	GPI_2
Pin3	GPO_4
Pin4	Ground

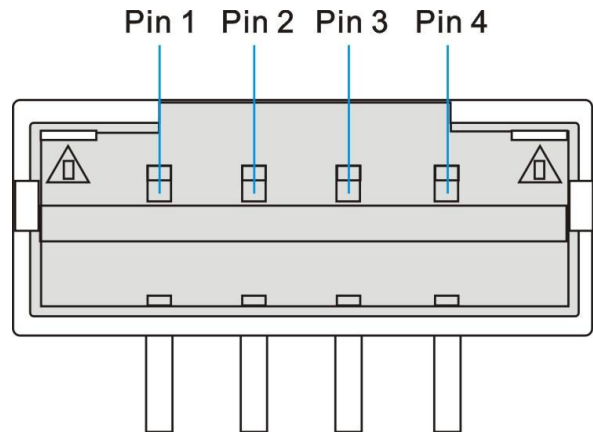

Federal Communication Commission Interference Statement

This device complies with Part 15 of the FCC Rules. Operation is subject to the following two conditions: (1) This device may not cause harmful interference, and (2) this device must accept any interference received, including interference that may cause undesired operation.

This equipment has been tested and found to comply with the limits for a Class B digital device, pursuant to Part 15 of the FCC Rules. These limits are designed to provide reasonable protection against harmful interference in a residential installation. This equipment generates, uses and can radiate radio frequency energy and, if not installed and used in accordance with the instructions, may cause harmful interference to radio communications. However, there is no guarantee that interference will not occur in a particular installation. If this equipment does cause harmful interference to radio or television reception, which can be determined by turning the equipment off and on, the user is encouraged to try to correct the interference by one of the following measures:

- Reorient or relocate the receiving antenna.
- Increase the separation between the equipment and receiver.
- Connect the equipment into an outlet on a circuit different from that to which the receiver is connected.
- Consult the dealer or an experienced radio/TV technician for help.

FCC Caution: Any changes or modifications not expressly approved by the party responsible for compliance could void the user's authority to operate this equipment.

This transmitter must not be co-located or operating in conjunction with any other antenna or transmitter.

Radiation Exposure Statement:

This equipment complies with FCC radiation exposure limits set forth for an uncontrolled environment. This equipment should be installed and operated with minimum distance 20cm between the radiator & your body.

台灣使用注意事項:

經型式認證合格之低功率射頻電機，非經許可，公司、商號或使用者均不得擅自變更頻率、加大功率或變更原設計之特性及功能。

低功率射頻電機之使用不得影響飛航安全及干擾合法通信；經發現有干擾現象時，應立即停用，並改善至無干擾時方得繼續使用。前項合法通信，指依電信法規定作業之無線電通信。低功率射頻電機須忍受合法通信或工業、科學及醫療用電波輻射性電機設備之干擾。