

# Product Specification for model DNUA-PO1 (QCA AR9375\_AL3D Base)

802.11n a/b/g USB Module

**Draft Version 0.2 2014/08/19**

**by  
Tina Lu**

**Datacomm product center  
Wistron Neweb® Corporation**

**Wistron Neweb® Corporation  
20 Park Avenue II Road, Hsinchu Science Park, Hsinchu 308, Taiwan, R.O.C.  
Tel: +886-3-666-7799  
Fax:+886-3-666-7323**

***Subject to change without notices***  
**© Copyrights by Wistron Neweb®**  
**All rights reserved**

- **Revision history**

<b>Revision</b>	<b>Change history</b>	<b>Date</b>
0.1	Initial draft version	2014/07/01
0.2	Add certification	2014/08/19

● Block diagram:

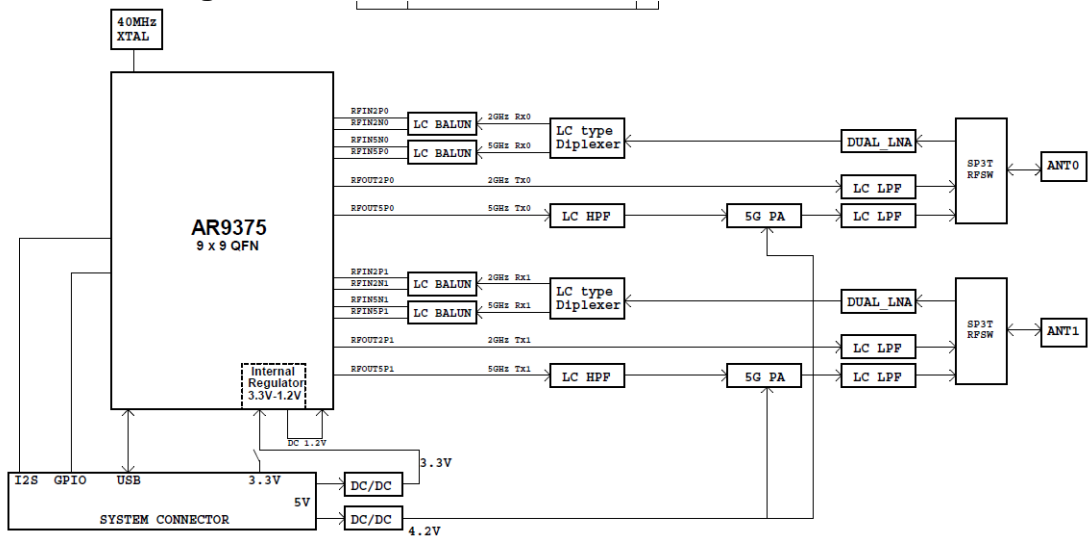

● PCBA outline drawing

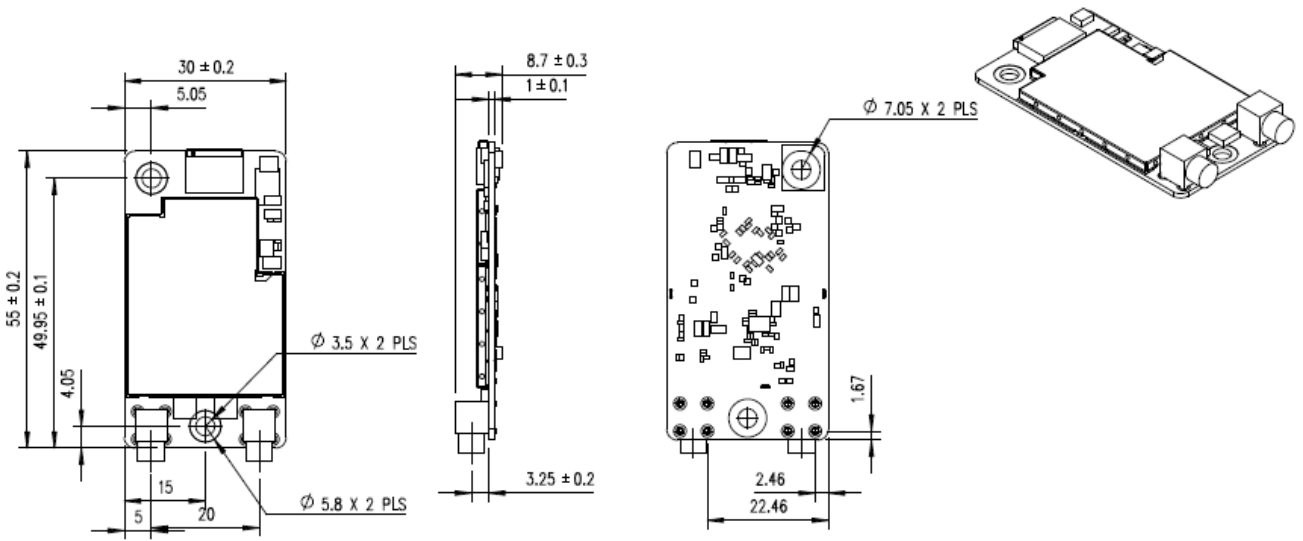

- PIN definition

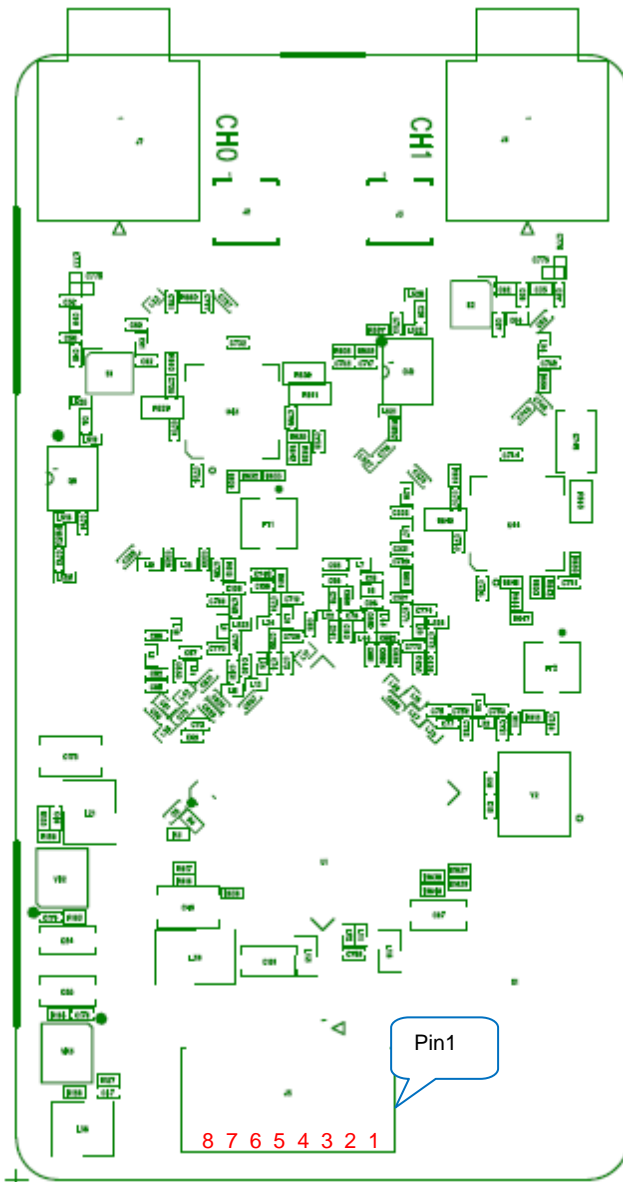

Pin No.	Description
Pin1	GND
Pin2	WAKE#
Pin3	W_RESET#
Pin4	USB_5V
Pin5	USB_5V
Pin6	USB_D-
Pin7	USB_D+
Pin8	GND

● DNUA-PO1, product specification, 802.11n a/b/g USB module

Item	Key specifications				
Main chipset	➢ QCA AR9375_AL3D				
TX/RX	➢ 2T2R				
Frequency range	➢ USA: 2.400 ~ 2.483GHz, 5.15 ~ 5.25GHz, 5.725 ~ 5.85GHz ➢ Europe: 2.400 ~ 2.483GHz, 5.15 ~ 5.25GHz ➢ Japan: 2.400 ~ 2.497GHz, 5.15 ~ 5.25GHz,				
Modulation technique	➢ 802.11 Legacy a/b/g DSSS (DBPSK, DQPSK, CCK) OFDM (BPSK, QPSK, 16-QAM, 64-QAM) DSSS (Direct Sequence Spread Spectrum) with DBPSK (Differential Binary Phase Shift Keying 1Mbps), DQPSK (Differential Quaternary Phase Shift Keying 2Mbps), and CCK (Complementary Code Keying 5.5&11Mbps), and OFDM (Orthogonal Frequency Division Multiplexing with BPSK for 6,9Mbps、QPSK for 12,18Mbps、16QAM for 24,36Mbps、64QAM for 48,54Mbps)  ➢ 802.11n a/g OFDM (BPSK, QPSK, 16-QAM, 64-QAM)				
Host interface	➢ USB 2.0				
Channels support	➢ 802.11n b/g US/Canada: 11 (1 ~ 11) Major European country: 13 (1 ~ 13) France: 4 (10 ~ 13) Japan: 11b: 14 (1~13 or 14 <sup>th</sup> ), 11g: 13 (1 ~ 13) ➢ 802.11n a 1). US/Canada: channels (36,40,44,48,52, 149,153,157,161,165) 2). Europe: channel (36,40,44,48,52) 3). Japan: channels ( 36,40,44,48,52)				
Operation voltage	➢ 5V +/- 5%				
Power consumption @25 o C	802.11ng MCS8(40MHz)		802.11na MCS8(40MHz)		
	(mA)	Avg	Avg		
	5V	350	756		
Output Power (Typical-for each chain; with ±2dB tolerance).	➢ 802.11a				
	Test Frequencies	6-24_Target	36_Target	48_Target	54_Target
This power table bases on the maximum HW capability complying with IEEE spec regardless the regulatory limitation	5180	21	20	19	17
	5320	21	20	19	17
	5500	21	20	19	17
	5600	21	20	19	17
	5700	21	20	19	17
	5825	21	20	19	17
	➢ 802.11b				
	Test Frequencies	1/2_Target	5.5_Target	11_Target	
	2412	16	16	16	
	2437	16	16	16	
	2472	16	16	16	
	➢ 802.11g				
	Test Frequencies	6-24_Target	36_Target	48_Target	54_Target
	2412	16	16	15	14
	2437	16	16	15	14
2472	16	16	15	14	
➢ 802.11n Freq. Range: HT20					

	<table border="1"> <thead> <tr> <th>Test Freq</th> <th>MCS 0/8</th> <th>MCS 1/9</th> <th>MCS 2/10</th> <th>MCS 3/11</th> <th>MCS 4/12</th> <th>MCS 5/13</th> <th>MCS 6/14</th> <th>MCS 7/15</th> </tr> </thead> <tbody> <tr><td>5180</td><td>21</td><td>21</td><td>21</td><td>21</td><td>20</td><td>20</td><td>19</td><td>17</td></tr> <tr><td>5240</td><td>21</td><td>21</td><td>21</td><td>21</td><td>20</td><td>20</td><td>19</td><td>17</td></tr> <tr><td>5320</td><td>21</td><td>21</td><td>21</td><td>21</td><td>20</td><td>20</td><td>19</td><td>17</td></tr> <tr><td>5500</td><td>21</td><td>21</td><td>21</td><td>21</td><td>20</td><td>20</td><td>19</td><td>17</td></tr> <tr><td>5700</td><td>21</td><td>21</td><td>21</td><td>21</td><td>20</td><td>20</td><td>19</td><td>17</td></tr> <tr><td>5745</td><td>21</td><td>21</td><td>21</td><td>21</td><td>20</td><td>20</td><td>19</td><td>17</td></tr> <tr><td>5825</td><td>21</td><td>21</td><td>21</td><td>21</td><td>20</td><td>20</td><td>19</td><td>17</td></tr> </tbody> </table> <p>Freq. Range: HT40</p> <table border="1"> <thead> <tr> <th>Test Freq</th> <th>MCS 0/8</th> <th>MCS 1/9</th> <th>MCS 2/10</th> <th>MCS 3/11</th> <th>MCS 4/12</th> <th>MCS 5/13</th> <th>MCS 6/14</th> <th>MCS 7/15</th> </tr> </thead> <tbody> <tr><td>5190</td><td>21</td><td>21</td><td>21</td><td>21</td><td>20</td><td>20</td><td>19</td><td>17</td></tr> <tr><td>5230</td><td>21</td><td>21</td><td>21</td><td>21</td><td>20</td><td>20</td><td>19</td><td>17</td></tr> <tr><td>5310</td><td>21</td><td>21</td><td>21</td><td>21</td><td>20</td><td>20</td><td>19</td><td>17</td></tr> <tr><td>5510</td><td>21</td><td>21</td><td>21</td><td>21</td><td>20</td><td>20</td><td>19</td><td>17</td></tr> <tr><td>5670</td><td>21</td><td>21</td><td>21</td><td>21</td><td>20</td><td>20</td><td>19</td><td>17</td></tr> <tr><td>5755</td><td>21</td><td>21</td><td>21</td><td>21</td><td>20</td><td>20</td><td>19</td><td>17</td></tr> <tr><td>5795</td><td>21</td><td>21</td><td>21</td><td>21</td><td>20</td><td>20</td><td>19</td><td>17</td></tr> </tbody> </table> <p>Freq. Range: HT20</p> <table border="1"> <thead> <tr> <th>Test Freq</th> <th>MCS 0/8</th> <th>MCS 1/9</th> <th>MCS 2/10</th> <th>MCS 3/11</th> <th>MCS 4/12</th> <th>MCS 5/13</th> <th>MCS 6/14</th> <th>MCS 7/15</th> </tr> </thead> <tbody> <tr><td>2412</td><td>16</td><td>16</td><td>16</td><td>16</td><td>15</td><td>15</td><td>14</td><td>14</td></tr> <tr><td>2437</td><td>16</td><td>16</td><td>16</td><td>16</td><td>15</td><td>15</td><td>14</td><td>14</td></tr> <tr><td>2472</td><td>16</td><td>16</td><td>16</td><td>16</td><td>15</td><td>15</td><td>14</td><td>14</td></tr> </tbody> </table> <p>Freq. Range: HT40</p> <table border="1"> <thead> <tr> <th>Test Freq</th> <th>MCS 0/8</th> <th>MCS 1/9</th> <th>MCS 2/10</th> <th>MCS 3/11</th> <th>MCS 4/12</th> <th>MCS 5/13</th> <th>MCS 6/14</th> <th>MCS 7/15</th> </tr> </thead> <tbody> <tr><td>2412</td><td>16</td><td>16</td><td>16</td><td>16</td><td>15</td><td>15</td><td>14</td><td>14</td></tr> <tr><td>2437</td><td>16</td><td>16</td><td>16</td><td>16</td><td>15</td><td>15</td><td>14</td><td>14</td></tr> <tr><td>2472</td><td>16</td><td>16</td><td>16</td><td>16</td><td>15</td><td>15</td><td>14</td><td>14</td></tr> </tbody> </table>	Test Freq	MCS 0/8	MCS 1/9	MCS 2/10	MCS 3/11	MCS 4/12	MCS 5/13	MCS 6/14	MCS 7/15	5180	21	21	21	21	20	20	19	17	5240	21	21	21	21	20	20	19	17	5320	21	21	21	21	20	20	19	17	5500	21	21	21	21	20	20	19	17	5700	21	21	21	21	20	20	19	17	5745	21	21	21	21	20	20	19	17	5825	21	21	21	21	20	20	19	17	Test Freq	MCS 0/8	MCS 1/9	MCS 2/10	MCS 3/11	MCS 4/12	MCS 5/13	MCS 6/14	MCS 7/15	5190	21	21	21	21	20	20	19	17	5230	21	21	21	21	20	20	19	17	5310	21	21	21	21	20	20	19	17	5510	21	21	21	21	20	20	19	17	5670	21	21	21	21	20	20	19	17	5755	21	21	21	21	20	20	19	17	5795	21	21	21	21	20	20	19	17	Test Freq	MCS 0/8	MCS 1/9	MCS 2/10	MCS 3/11	MCS 4/12	MCS 5/13	MCS 6/14	MCS 7/15	2412	16	16	16	16	15	15	14	14	2437	16	16	16	16	15	15	14	14	2472	16	16	16	16	15	15	14	14	Test Freq	MCS 0/8	MCS 1/9	MCS 2/10	MCS 3/11	MCS 4/12	MCS 5/13	MCS 6/14	MCS 7/15	2412	16	16	16	16	15	15	14	14	2437	16	16	16	16	15	15	14	14	2472	16	16	16	16	15	15	14	14
Test Freq	MCS 0/8	MCS 1/9	MCS 2/10	MCS 3/11	MCS 4/12	MCS 5/13	MCS 6/14	MCS 7/15																																																																																																																																																																																																																	
5180	21	21	21	21	20	20	19	17																																																																																																																																																																																																																	
5240	21	21	21	21	20	20	19	17																																																																																																																																																																																																																	
5320	21	21	21	21	20	20	19	17																																																																																																																																																																																																																	
5500	21	21	21	21	20	20	19	17																																																																																																																																																																																																																	
5700	21	21	21	21	20	20	19	17																																																																																																																																																																																																																	
5745	21	21	21	21	20	20	19	17																																																																																																																																																																																																																	
5825	21	21	21	21	20	20	19	17																																																																																																																																																																																																																	
Test Freq	MCS 0/8	MCS 1/9	MCS 2/10	MCS 3/11	MCS 4/12	MCS 5/13	MCS 6/14	MCS 7/15																																																																																																																																																																																																																	
5190	21	21	21	21	20	20	19	17																																																																																																																																																																																																																	
5230	21	21	21	21	20	20	19	17																																																																																																																																																																																																																	
5310	21	21	21	21	20	20	19	17																																																																																																																																																																																																																	
5510	21	21	21	21	20	20	19	17																																																																																																																																																																																																																	
5670	21	21	21	21	20	20	19	17																																																																																																																																																																																																																	
5755	21	21	21	21	20	20	19	17																																																																																																																																																																																																																	
5795	21	21	21	21	20	20	19	17																																																																																																																																																																																																																	
Test Freq	MCS 0/8	MCS 1/9	MCS 2/10	MCS 3/11	MCS 4/12	MCS 5/13	MCS 6/14	MCS 7/15																																																																																																																																																																																																																	
2412	16	16	16	16	15	15	14	14																																																																																																																																																																																																																	
2437	16	16	16	16	15	15	14	14																																																																																																																																																																																																																	
2472	16	16	16	16	15	15	14	14																																																																																																																																																																																																																	
Test Freq	MCS 0/8	MCS 1/9	MCS 2/10	MCS 3/11	MCS 4/12	MCS 5/13	MCS 6/14	MCS 7/15																																																																																																																																																																																																																	
2412	16	16	16	16	15	15	14	14																																																																																																																																																																																																																	
2437	16	16	16	16	15	15	14	14																																																																																																																																																																																																																	
2472	16	16	16	16	15	15	14	14																																																																																																																																																																																																																	
EVM	<p>The transmit modulation accuracy is measured using error vector magnitude (EVM). EVM is the magnitude of the phase difference as a function of time between an ideal reference signal and the measured transmitted signal.</p> <ul style="list-style-type: none"> <li>➤ 802.11a <table border="1"> <thead> <tr> <th>Modulation</th> <th>Code Rate</th> <th>Relative constellation error (dB) IEEE Spec (1Tx dB)</th> <th>Relative constellation error (dB) Typical (1Tx dB)</th> </tr> </thead> <tbody> <tr><td>BPSK</td><td>1/2</td><td>-5</td><td>-25</td></tr> <tr><td>BPSK</td><td>3/4</td><td>-8</td><td>-25</td></tr> <tr><td>QPSK</td><td>1/2</td><td>-10</td><td>-25</td></tr> <tr><td>QPSK</td><td>3/4</td><td>-13</td><td>-25</td></tr> <tr><td>16-QAM</td><td>1/2</td><td>-16</td><td>-25</td></tr> <tr><td>16-QAM</td><td>3/4</td><td>-19</td><td>-28</td></tr> <tr><td>64-QAM</td><td>2/3</td><td>-22</td><td>-30</td></tr> <tr><td>64-QAM</td><td>3/4</td><td>-25</td><td>-31</td></tr> </tbody> </table> </li> <li>➤ 802.11b <table border="1"> <thead> <tr> <th>Modulation</th> <th>Code Rate</th> <th>Relative constellation error (dB) IEEE Spec (1Tx dB)</th> <th>Relative constellation error (dB) Typical (1Tx dB)</th> </tr> </thead> <tbody> <tr><td>DBPSK</td><td></td><td>-10</td><td>-28</td></tr> <tr><td>DQPSK</td><td></td><td>-10</td><td>-28</td></tr> <tr><td>CCK</td><td></td><td>-10</td><td>-28</td></tr> </tbody> </table> </li> <li>➤ 802.11g <table border="1"> <thead> <tr> <th>Modulation</th> <th>Code Rate</th> <th>Relative constellation error (dB) IEEE Spec (1Tx dB)</th> <th>Relative constellation error (dB) Typical (1Tx dB)</th> </tr> </thead> <tbody> <tr><td>BPSK</td><td>1/2</td><td>-5</td><td>-28</td></tr> <tr><td>BPSK</td><td>3/4</td><td>-8</td><td>-28</td></tr> <tr><td>QPSK</td><td>1/2</td><td>-10</td><td>-28</td></tr> <tr><td>QPSK</td><td>3/4</td><td>-13</td><td>-28</td></tr> <tr><td>16-QAM</td><td>1/2</td><td>-16</td><td>-28</td></tr> </tbody> </table> </li> </ul>	Modulation	Code Rate	Relative constellation error (dB) IEEE Spec (1Tx dB)	Relative constellation error (dB) Typical (1Tx dB)	BPSK	1/2	-5	-25	BPSK	3/4	-8	-25	QPSK	1/2	-10	-25	QPSK	3/4	-13	-25	16-QAM	1/2	-16	-25	16-QAM	3/4	-19	-28	64-QAM	2/3	-22	-30	64-QAM	3/4	-25	-31	Modulation	Code Rate	Relative constellation error (dB) IEEE Spec (1Tx dB)	Relative constellation error (dB) Typical (1Tx dB)	DBPSK		-10	-28	DQPSK		-10	-28	CCK		-10	-28	Modulation	Code Rate	Relative constellation error (dB) IEEE Spec (1Tx dB)	Relative constellation error (dB) Typical (1Tx dB)	BPSK	1/2	-5	-28	BPSK	3/4	-8	-28	QPSK	1/2	-10	-28	QPSK	3/4	-13	-28	16-QAM	1/2	-16	-28																																																																																																																																												
Modulation	Code Rate	Relative constellation error (dB) IEEE Spec (1Tx dB)	Relative constellation error (dB) Typical (1Tx dB)																																																																																																																																																																																																																						
BPSK	1/2	-5	-25																																																																																																																																																																																																																						
BPSK	3/4	-8	-25																																																																																																																																																																																																																						
QPSK	1/2	-10	-25																																																																																																																																																																																																																						
QPSK	3/4	-13	-25																																																																																																																																																																																																																						
16-QAM	1/2	-16	-25																																																																																																																																																																																																																						
16-QAM	3/4	-19	-28																																																																																																																																																																																																																						
64-QAM	2/3	-22	-30																																																																																																																																																																																																																						
64-QAM	3/4	-25	-31																																																																																																																																																																																																																						
Modulation	Code Rate	Relative constellation error (dB) IEEE Spec (1Tx dB)	Relative constellation error (dB) Typical (1Tx dB)																																																																																																																																																																																																																						
DBPSK		-10	-28																																																																																																																																																																																																																						
DQPSK		-10	-28																																																																																																																																																																																																																						
CCK		-10	-28																																																																																																																																																																																																																						
Modulation	Code Rate	Relative constellation error (dB) IEEE Spec (1Tx dB)	Relative constellation error (dB) Typical (1Tx dB)																																																																																																																																																																																																																						
BPSK	1/2	-5	-28																																																																																																																																																																																																																						
BPSK	3/4	-8	-28																																																																																																																																																																																																																						
QPSK	1/2	-10	-28																																																																																																																																																																																																																						
QPSK	3/4	-13	-28																																																																																																																																																																																																																						
16-QAM	1/2	-16	-28																																																																																																																																																																																																																						

	16-QAM	3/4	-19	-29
	64-QAM	2/3	-22	-29
	64-QAM	3/4	-25	-29
➤	<b>802.11ng</b>			
	<b>Modulation</b>	<b>Code Rate</b>	<b>Relative constellation error (dB) IEEE Spec (1Tx dB)</b>	<b>Relative constellation error (dB) Typical (1Tx dB)</b>
✧	<b>HT20</b>			
	(MCS0) BPSK	1/2	-5	-25
	(MCS1) QPSK	1/2	-10	-26
	(MCS2) QPSK	3/4	-13	-26
	(MCS3) 16-QAM	1/2	-16	-26
	(MCS4) 16-QAM	3/4	-19	-29
	(MCS5) 64-QAM	2/3	-22	-30
	(MCS6) 64-QAM	3/4	-25	-30
	(MCS7) 64-QAM	5/6	-27	-31
	(MCS8) BPSK	1/2	-5	-25
	(MCS9) QPSK	1/2	-10	-26
	(MCS10) QPSK	3/4	-13	-26
	(MCS11) 16-QAM	1/2	-16	-26
	(MCS12) 16-QAM	3/4	-19	-29
	(MCS13) 64-QAM	2/3	-22	-30
	(MCS14) 64-QAM	3/4	-25	-30
	(MCS15) 64-QAM	5/6	-27	-31
✧	<b>HT40</b>			
	(MCS0) BPSK	1/2	-5	-26
	(MCS1) QPSK	1/2	-10	-27
	(MCS2) QPSK	3/4	-13	-27
	(MCS3) 16-QAM	1/2	-16	-27
	(MCS4) 16-QAM	3/4	-19	-29
	(MCS5) 64-QAM	2/3	-22	-30
	(MCS6) 64-QAM	3/4	-25	-30
	(MCS7) 64-QAM	5/6	-27	-31
	(MCS8) BPSK	1/2	-5	-26
	(MCS9) QPSK	1/2	-10	-27
	(MCS10) QPSK	3/4	-13	-27
	(MCS11) 16-QAM	1/2	-16	-27
	(MCS12) 16-QAM	3/4	-19	-29
	(MCS13) 64-QAM	2/3	-22	-30
	(MCS14) 64-QAM	3/4	-25	-30
	(MCS15) 64-QAM	5/6	-27	-31
➤	<b>802.11na</b>			
	<b>Modulation</b>	<b>Code Rate</b>	<b>Relative constellation error (dB) IEEE Spec (1Tx dB)</b>	<b>Relative constellation error (dB) Typical (1Tx dB)</b>
✧	<b>HT20</b>			
	(MCS0) BPSK	1/2	-5	-25
	(MCS1) QPSK	1/2	-10	-26
	(MCS2) QPSK	3/4	-13	-26
	(MCS3) 16-QAM	1/2	-16	-26
	(MCS4) 16-QAM	3/4	-19	-29
	(MCS5) 64-QAM	2/3	-22	-30
	(MCS6) 64-QAM	3/4	-25	-30
	(MCS7) 64-QAM	5/6	-27	-31
	(MCS8) BPSK	1/2	-5	-25
	(MCS9) QPSK	1/2	-10	-26
	(MCS10) QPSK	3/4	-13	-26

	(MCS11) 16-QAM	1/2	-16	-26
	(MCS12) 16-QAM	3/4	-19	-29
	(MCS13) 64-QAM	2/3	-22	-30
	(MCS14) 64-QAM	3/4	-25	-30
	(MCS15) 64-QAM	5/6	-27	-31
	◇ HT40			
	(MCS0) BPSK	1/2	-5	-26
	(MCS1) QPSK	1/2	-10	-27
	(MCS2) QPSK	3/4	-13	-27
	(MCS3) 16-QAM	1/2	-16	-27
	(MCS4) 16-QAM	3/4	-19	-29
	(MCS5) 64-QAM	2/3	-22	-30
	(MCS6) 64-QAM	3/4	-25	-30
	(MCS7) 64-QAM	5/6	-27	-31
	(MCS8) BPSK	1/2	-5	-26
	(MCS9) QPSK	1/2	-10	-27
	(MCS10) QPSK	3/4	-13	-27
	(MCS11) 16-QAM	1/2	-16	-27
	(MCS12) 16-QAM	3/4	-19	-29
	(MCS13) 64-QAM	2/3	-22	-30
	(MCS14) 64-QAM	3/4	-25	-30
	(MCS15) 64-QAM	5/6	-27	-31
Sensitivity (1RX with +4/-2dB tolerance, dBm)	➤ 802.11a			
	Modulation	Code Rate	IEEE Spec (1Rx dBm)	Typical (1Rx dBm)
	BPSK	1/2	-82	-88
	BPSK	3/4	-81	-86
	QPSK	1/2	-79	-85
	QPSK	3/4	-77	-83
	16-QAM	1/2	-74	-79
	16-QAM	3/4	-70	-77
	64-QAM	2/3	-66	-73
	64-QAM	3/4	-65	-70
	➤ 802.11b			
	Modulation		IEEE Spec (1Rx dBm)	Typical (1Rx dBm)
	DBPSK		not specified	-93
	DQPSK		not specified	-91
	CCK		not specified	-87
	➤ 802.11g			
	Modulation	Code Rate	IEEE Spec (1Rx dBm)	Typical (1Rx dBm)
	BPSK	1/2	-82	-93
	BPSK	3/4	-81	-91
	QPSK	1/2	-79	-89
	QPSK	3/4	-77	-86
	16-QAM	1/2	-74	-83
	16-QAM	3/4	-70	-80
	64-QAM	2/3	-66	-75
	64-QAM	3/4	-65	-70
	➤ 802.11ng			
	Modulation	Code Rate	IEEE Spec (1Rx dBm)	Typical (1Rx dBm)
	◇ HT20			
	(MCS0) BPSK	1/2	-82	-90
	(MCS1) QPSK	1/2	-79	-87
	(MCS2) QPSK	3/4	-77	-86



	<p>(MCS3) 16-QAM 1/2 -74 -84</p> <p>(MCS4) 16-QAM 3/4 -70 -80</p> <p>(MCS5) 64-QAM 2/3 -66 -77</p> <p>(MCS6) 64-QAM 3/4 -65 -72</p> <p>(MCS7) 64-QAM 5/6 -64 -67</p> <p>◇ HT40</p> <p>(MCS0) BPSK 1/2 -79 -88</p> <p>(MCS1) QPSK 1/2 -76 -86</p> <p>(MCS2) QPSK 3/4 -74 -84</p> <p>(MCS3) 16-QAM 1/2 -71 -80</p> <p>(MCS4) 16-QAM 3/4 -67 -78</p> <p>(MCS5) 64-QAM 2/3 -63 -73</p> <p>(MCS6) 64-QAM 3/4 -62 -70</p> <p>(MCS7) 64-QAM 5/6 -61 -64</p> <p>➤ 802.11na</p> <table border="1"> <thead> <tr> <th>Modulation</th> <th>Code Rate</th> <th>IEEE Spec (1Rx dBm)</th> <th>Typical (1Rx dBm)</th> </tr> </thead> <tbody> <tr> <td colspan="4">◇ HT20</td> </tr> <tr> <td>(MCS0) BPSK</td> <td>1/2</td> <td>-82</td> <td>-89</td> </tr> <tr> <td>(MCS1) QPSK</td> <td>1/2</td> <td>-79</td> <td>-87</td> </tr> <tr> <td>(MCS2) QPSK</td> <td>3/4</td> <td>-77</td> <td>-84</td> </tr> <tr> <td>(MCS3) 16-QAM</td> <td>1/2</td> <td>-74</td> <td>-80</td> </tr> <tr> <td>(MCS4) 16-QAM</td> <td>3/4</td> <td>-70</td> <td>-77</td> </tr> <tr> <td>(MCS5) 64-QAM</td> <td>2/3</td> <td>-66</td> <td>-72</td> </tr> <tr> <td>(MCS6) 64-QAM</td> <td>3/4</td> <td>-65</td> <td>-71</td> </tr> <tr> <td>(MCS7) 64-QAM</td> <td>5/6</td> <td>-64</td> <td>-67</td> </tr> <tr> <td colspan="4">◇ HT40</td> </tr> <tr> <td>(MCS0) BPSK</td> <td>1/2</td> <td>-79</td> <td>-84</td> </tr> <tr> <td>(MCS1) QPSK</td> <td>1/2</td> <td>-76</td> <td>-81</td> </tr> <tr> <td>(MCS2) QPSK</td> <td>3/4</td> <td>-74</td> <td>-79</td> </tr> <tr> <td>(MCS3) 16-QAM</td> <td>1/2</td> <td>-71</td> <td>-76</td> </tr> <tr> <td>(MCS4) 16-QAM</td> <td>3/4</td> <td>-67</td> <td>-72</td> </tr> <tr> <td>(MCS5) 64-QAM</td> <td>2/3</td> <td>-63</td> <td>-70</td> </tr> <tr> <td>(MCS6) 64-QAM</td> <td>3/4</td> <td>-62</td> <td>-67</td> </tr> <tr> <td>(MCS7) 64-QAM</td> <td>5/6</td> <td>-61</td> <td>-64</td> </tr> </tbody> </table>	Modulation	Code Rate	IEEE Spec (1Rx dBm)	Typical (1Rx dBm)	◇ HT20				(MCS0) BPSK	1/2	-82	-89	(MCS1) QPSK	1/2	-79	-87	(MCS2) QPSK	3/4	-77	-84	(MCS3) 16-QAM	1/2	-74	-80	(MCS4) 16-QAM	3/4	-70	-77	(MCS5) 64-QAM	2/3	-66	-72	(MCS6) 64-QAM	3/4	-65	-71	(MCS7) 64-QAM	5/6	-64	-67	◇ HT40				(MCS0) BPSK	1/2	-79	-84	(MCS1) QPSK	1/2	-76	-81	(MCS2) QPSK	3/4	-74	-79	(MCS3) 16-QAM	1/2	-71	-76	(MCS4) 16-QAM	3/4	-67	-72	(MCS5) 64-QAM	2/3	-63	-70	(MCS6) 64-QAM	3/4	-62	-67	(MCS7) 64-QAM	5/6	-61	-64
Modulation	Code Rate	IEEE Spec (1Rx dBm)	Typical (1Rx dBm)																																																																										
◇ HT20																																																																													
(MCS0) BPSK	1/2	-82	-89																																																																										
(MCS1) QPSK	1/2	-79	-87																																																																										
(MCS2) QPSK	3/4	-77	-84																																																																										
(MCS3) 16-QAM	1/2	-74	-80																																																																										
(MCS4) 16-QAM	3/4	-70	-77																																																																										
(MCS5) 64-QAM	2/3	-66	-72																																																																										
(MCS6) 64-QAM	3/4	-65	-71																																																																										
(MCS7) 64-QAM	5/6	-64	-67																																																																										
◇ HT40																																																																													
(MCS0) BPSK	1/2	-79	-84																																																																										
(MCS1) QPSK	1/2	-76	-81																																																																										
(MCS2) QPSK	3/4	-74	-79																																																																										
(MCS3) 16-QAM	1/2	-71	-76																																																																										
(MCS4) 16-QAM	3/4	-67	-72																																																																										
(MCS5) 64-QAM	2/3	-63	-70																																																																										
(MCS6) 64-QAM	3/4	-62	-67																																																																										
(MCS7) 64-QAM	5/6	-61	-64																																																																										
Transmit spectrum mask	<p>➤ For transmitted spectral mask for 11a shall be less than -40dBm for <math>f_c-30\text{MHz} &lt; f &lt; f_c+30\text{MHz}</math>.</p> <p>➤ For transmitted spectral mask for 11b shall be less than -50dBm for <math>f_c-22\text{MHz} &lt; f &lt; f_c+22\text{MHz}</math>.</p> <p>➤ For transmitted spectral mask for 11g shall be less than -40dBm for <math>f_c-30\text{MHz} &lt; f &lt; f_c+30\text{MHz}</math>.</p> <p>➤ For transmitted spectral mask for 11n 20MHz shall be less than -45dBm for <math>f_c-30\text{MHz} &lt; f &lt; f_c+30\text{MHz}</math>.</p> <p>➤ For transmitted spectral mask for 11n 40MHz shall be less than -45dBm for <math>f_c-60\text{MHz} &lt; f &lt; f_c+60\text{MHz}</math>.</p>																																																																												
Transmit spectrum flatness	<p>➤ For 802.11a/g the average energy of the constellations in each of spectral lines -16..-1 and +1..+16 will deviate no more than +/- 2dB from their average energy.</p> <p>For 802.11n 40MHz mode, the average energy of the constellations in each of spectral lines -42..-2 and +2..+42 will deviate no more than +/- 2dB from their average energy.</p> <p>➤ The transmitted spectral flatness should be within +/- 4dB.</p>																																																																												
Transmit center frequency tolerance	<p>➤ The transmitted center frequency tolerance shall be <math>\pm 20</math> ppm maximum.</p>																																																																												
Receiver	<p>➤ 802.11a</p>																																																																												

maximum input level	Modulation	Code Rate	IEEE Spec (1Rx dBm) >-30	
	➤ 802.11b Modulation		IEEE Spec (1Rx dBm) >-10	
	DBPSK		>-10	
	DQPSK		>-10	
	CCK		>-10	
➤ 802.11g Modulation	Code Rate	IEEE Spec (1Rx dBm) >-20		
➤ 802.11na Modulation	Code Rate	IEEE Spec (1Rx dBm) >-30		
➤ 802.11ng Modulation	Code Rate	IEEE Spec (1Rx dBm) >-20		
Operation system supported	➤ Linux & Windows			
PCB dimension	➤ 30mm x 55mm ; 4 Layer; FR4			
Transfer data rate	➤ 802.11a: 6, 9, 12, 18, 24, 36, 48, 54Mbps ➤ 802.11b: 1, 2, 5.5, 11Mbps ➤ 802.11g: 6, 9, 12, 18, 24, 36, 48, 54Mbps ➤ 802.11n: @800GI(400GI) <ul style="list-style-type: none"> <li>● 20MHz BW                         <ul style="list-style-type: none"> <li>▪ 1 Nss: 65(72.2) Mbps maximal</li> <li>▪ 2 Nss: 130(144.444) Mbps maximal</li> </ul> </li> <li>● 40MHz BW                         <ul style="list-style-type: none"> <li>▪ 1 Nss: 135(150) Mbps maximal</li> <li>▪ 2 Nss: 270(300) Mbps maximal</li> </ul> </li> </ul>			
Operation temperature	➤ 0° ~ 50° C			
Storage temperature	➤ -20° ~ 80° C			
Antenna type	➤ MCX connector for external Antenna ➤ Reserve U.FL connector for external Antenna			
Certification	➤			
		Certification	Standard	
	CE		EN 300 328 V1.8.1	2.4G, No diversity
			EN 301 893 V1.7.1	5G B1 ( 5150~5250MHz), No diversity
			EN301489-1/-17	RF EMC
			EN 60950-1(LVD)	Safety
	FCC		Part 15B	EMI
			Part 15C (15.247)	2.4G, No diversity
			Part 15E (15.407)	5G B1&B4 (5150~5250MHz, 5725~5850MHz), No diversity
			FCC ID Fee	TCB filing

	ICC	ICES-003	to be included in FCC 15B
		RSS-210	2.4G (refer to FCC result)
		RSS-210	5G B4 (5725~5825MHz), partial refer to FCC result Pls note that FCC 15.407 power is at least 5 dBm lower than FCC 15.247 5G B1, radiation use FCC result, this band is indoor use only
		IC grant	FCB filing
	TELEC (JPN)	ARIB STD-T66	2.4G ( 1~13ch)
		ARIB STD-T33	2.4G (14ch)
		ARIB STD-T71	W52(5150~5250MHz) indoor only
		TELEC filing ( T66+T71)	Granted by telefication
		TELEC filing (T33)	Granted by telefication