

Integrated Electric Steamer Module

MODEL IS15/S

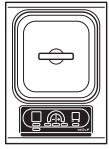

Model IS15/S

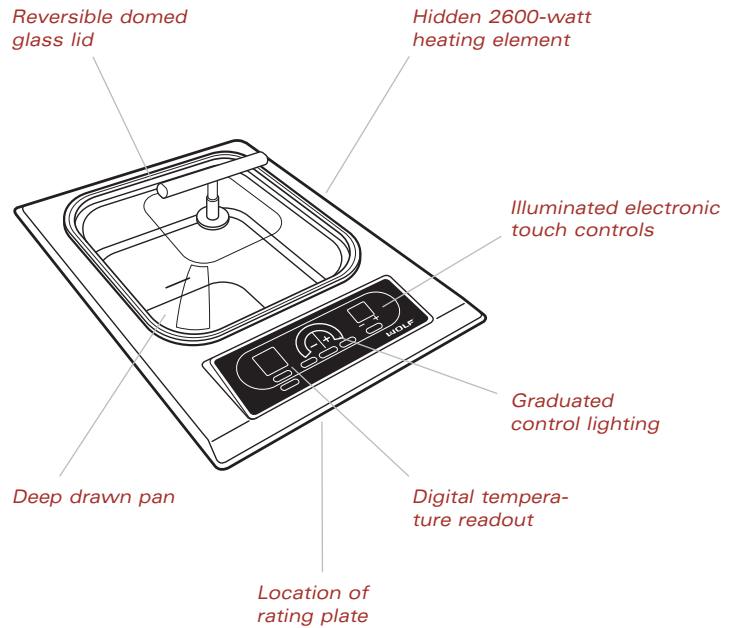

► The Wolf Model IS15/S 15" (381) integrated electric steamer module is available in the classic stainless steel finish.



This appliance is certified by Star-K to meet strict religious regulations in conjunction with specific instructions found on www.star-k.org.

From a temperature of 140°F (60°C) to boil, you can keep food hot for long periods of time or defrost easily without drying out or losing its flavor.

The beauty of this module is accented by the sculptured glass domed lid, which is easily inverted for storage to keep a low profile.

The deep, large vessel with a two gallon (7.6 L) capacity can hold up to 14 cups of cooked pasta and includes one solid and one perforated stackable insert pan.

The Wolf electric steamer module is available in classic stainless steel.

With Wolf's integrated modules, you have the ultimate in customization. You can create your own design by mixing and matching the various components within this system.

Integrated Electric Steamer Module MODEL IS15/S

FEATURES

- ▶ Integrated design allows for installation of multiple cooktops or modules
- ▶ Stainless steel top construction with classic stainless steel finish
- ▶ Hidden 2600-watt heating element
- ▶ Illuminated electronic touch controls with graduated control lighting
- ▶ Large two-gallon (7.6 L) maximum capacity tub—10-cup capacity for steaming
- ▶ Two stackable stainless steel steamer insert pans—one solid and one perforated
- ▶ Uses include steaming vegetables, eggs and custard, double boiling, proofing bread dough, warming food and melting chocolate
- ▶ Can function as a slow cooker for 8-10 hours
- ▶ Reversible domed glass lid for easy storage
- ▶ Independent digital timer
- ▶ Digital temperature readout and preheat indicator
- ▶ Electronic drain
- ▶ CSA certified for US and Canada
- ▶ Two and five year residential warranty—exclusions apply; warranty information can be found on our website, wolfappliance.com

OVERALL DIMENSIONS ▼

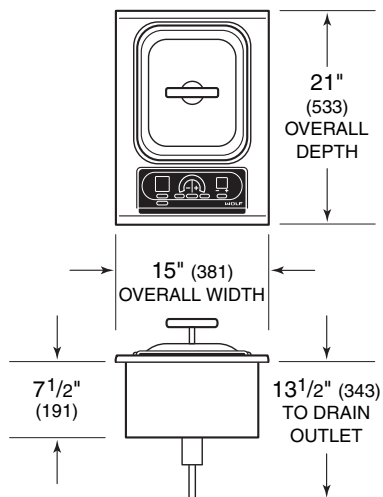

Unit dimensions may vary by $\pm 1/8"$ (3).

Dimensions in parentheses are in millimeters unless otherwise specified.

Integrated Electric Steamer Module

MODEL IS15/S



Model IS15/S

VENTILATION OPTIONS

- ▶ 30" (762) Cooktop hood or Pro wall or wall chimney hood or liner
- ▶ 36" (914) Pro island hood

For additional information, refer to the Cooktop or Pro Ventilation sections of our website, wolfappliance.com.

ACCESSORIES

- ▶ Filler strip

Accessories are available through your Wolf dealer. To obtain local dealer information, visit the Showroom Locator section of our website, wolfappliance.com.

SPECIFICATIONS

Overall Cooktop Width	15" (381)
Overall Cooktop Height	13 1/2" (343)
Overall Cooktop Depth	21" (533)
Heating Element	2600 W
Minimum Cabinet Depth	22 3/4" (578)
Minimum Height Clearance	13 1/2" (343)
Cooktop Cut-Out Width	14" (356)
Cooktop Cut-Out Depth	19 1/4" (489)
Electrical Supply Requirements	240/208 V AC, 60 Hz 15 amp circuit
Conduit	4 ft (1.2 m) flexible 3-wire
Electrical Rating	2.6 kW at 240 V 1.9 kW at 208 V
Shipping Weight	40 lbs (18 kg)
Special Note	Module can be installed in combination with other cooktops or modules

Specifications are subject to change without notice.

Unit dimensions may vary by ± 1/8" (3).

Dimensions in parentheses are in millimeters unless otherwise specified.

Integrated Electric Steamer Module
MODEL IS15/S

INSTALLATION SPECIFICATIONS

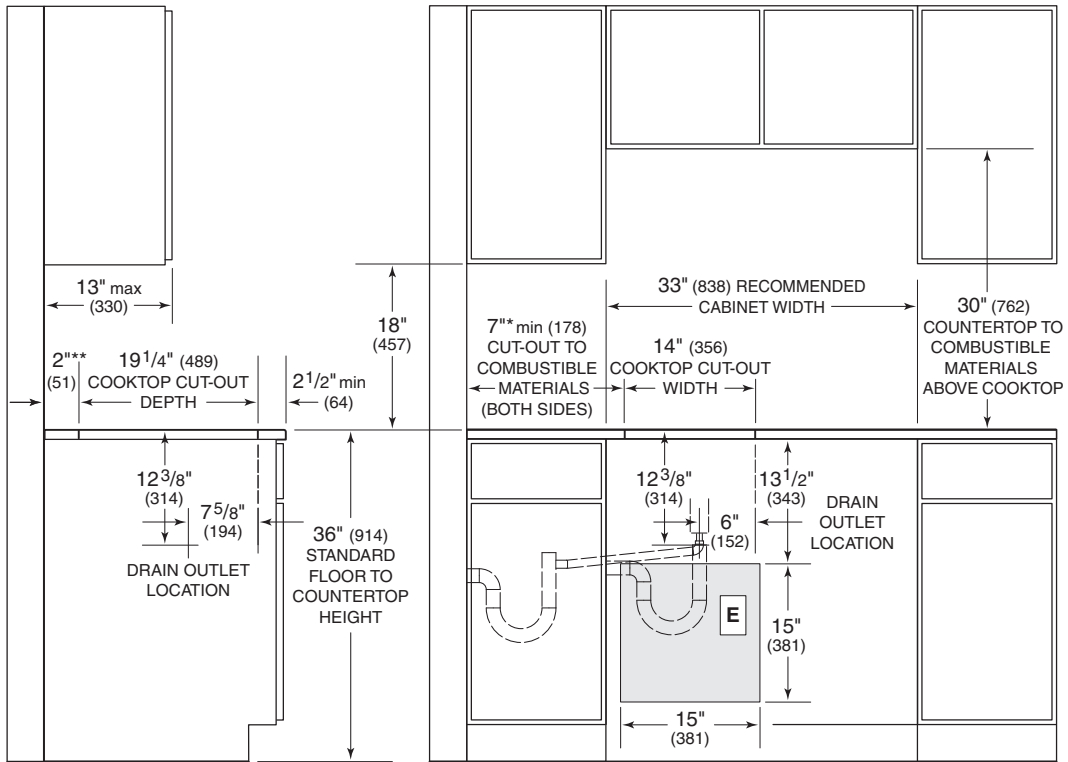

NOTE: Application shown allows for installation of two 15" (381) modules side-by-side with 33" (838) recommended cabinet width. 18" (457) recommended cabinet width for installation of single 15" (381) cooktop or module. *Minimum clearance from both side edges of cooktop cut-out to combustible materials up to 18" (457) above countertop. **Minimum clearance from rear edge of cooktop cut-out to combustible materials up to 18" (457) above countertop.

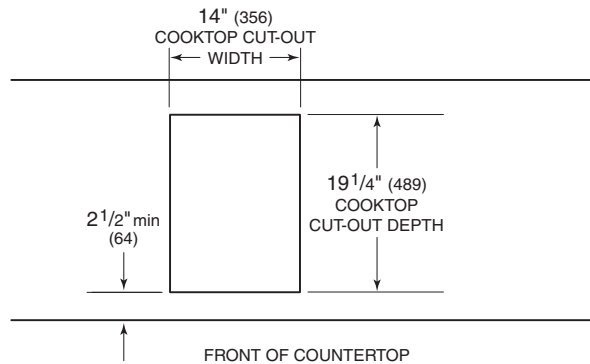

DIMENSIONS

Minimum Cabinet Depth	22 ³ / ₄ " (578)
Cooktop Cut-Out Width	14" (356)
Cooktop Cut-Out Depth	19 ¹ / ₄ " (489)
Location of Electrical	Within shaded area

See Installation Instructions shipped with unit for detailed specifications.

Integrated Electric Steamer Module MODEL IS15/S

INSTALLATION NOTES

▶ Refer to the illustrations and specifications for overall dimensions, cut-out dimensions and installation specifics.

▶ Wolf recommends using 33" (838) wide cabinets for installation of two integrated modules side by side. An 18" (457) wide cabinet is recommended for installation of a single integrated cooktop module.

IMPORTANT NOTE: Review specific installation instructions for product to product capabilities

▶ When multiple cooktops or modules are installed side by side, refer to the countertop cut-out dimensions on page 6.

⚠ WARNING

This steamer module must be installed at least 15" (381) away from a Wolf fryer module, as contact between water and hot oil may cause burns from steam and hot oil.

▶ A Wolf Cooktop or Pro ventilation hood is recommended. When installing a ventilation hood, refer to the specific requirements of the hood for the minimum dimension to countertop. Also refer to the ventilation recommendation charts in the cooktop or Pro ventilation sections of our website, wolfappliance.com.

IMPORTANT NOTE: Wolf does not recommend the use of downdraft ventilation with the integrated steamer module.

▶ The Wolf integrated steamer module requires a separate, grounded 3-wire 240/208 V AC, 60 Hz, 15 amp service with its own circuit breaker. It has a 4' (1.2 m) flexible 3-wire conduit for connection at the electrical supply. Locate electrical within the shaded area shown in the illustration on page 4.

▶ You must follow all National Electrical Code regulations. In addition, be aware of local codes and ordinances when installing your service.

▶ For the drain connection, the $\frac{5}{8}$ " (16) outlet from the valve will accept a drain hose that must flow downward to and tie into an existing sink drain, or a separate drain with a freefall may be installed. Following local building codes, your plumber will dictate how to plumb the unit. As a third option, the consumer will supply a heat resistant bucket for drainage in the location of the drain outlet. Refer to the illustration on page 4 for location of the drain outlet.

▶ Refer to the installation instructions shipped with each Wolf product for detailed specifications.

⚠ WARNING

This cooktop is intended for indoor use only.

Integrated Electric Steamer Module MODEL IS15/S

MULTIPLE COOKTOP INSTALLATION

With Wolf's integrated modules, you have the ultimate in customization. You can create your own design by mixing and matching the various components within this system. And when you couple these modules with other cooktops within the Wolf inventory you and your client will truly understand freedom of choice.

Some Wolf integrated modules can be installed together or with a 30" (762) or 36" (914) cooktop. When multiple units are installed side by side, the cut-out dimensions that are shown in the illustration are derived by adding 1 1/4" (32) additional space for each additional unit, to give you your total cut-out width. Refer to the illustration below for countertop cut-out dimensions for installation of multiple cooktop units.

When two or more cooktops or modules are installed together, an accessory filler strip is recommended. Refer to Accessories on page 3.

IMPORTANT NOTE: When multiple cooktops and/or modules are installed side by side, each unit must have its own separate recommended electrical circuit. When multiple gas cooktops and/or modules are installed next to one another, they can receive their gas supply from a common line. However, each unit must have its own regulator installed between the mainline and the cooktop or module.

IMPORTANT NOTE: Review specifications for each specific integrated module for installation requirements and limitations. Refer to the integrated modules section of our website, wolfappliance.com.

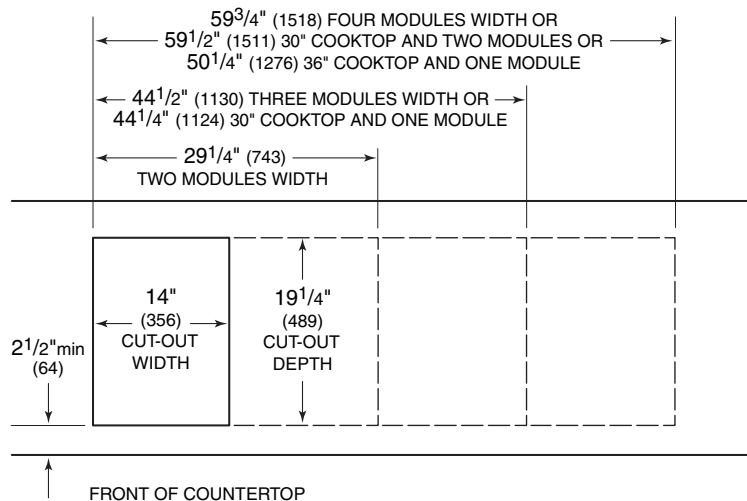

Countertop cut-out dimensions for installation of multiple cooktop units.